



Infor XA – Product Data Management User's Guide

Important Notices

The material contained in this publication (including any supplementary information) constitutes and contains confidential and proprietary information of Infor.

By gaining access to the attached, you acknowledge and agree that the material (including any modification, translation or adaptation of the material) and all copyright, trade secrets and all other right, title and interest therein, are the sole property of Infor and that you shall not gain right, title or interest in the material (including any modification, translation or adaptation of the material) by virtue of your review thereof other than the non-exclusive right to use the material solely in connection with and the furtherance of your license and use of software made available to your company from Infor pursuant to a separate agreement, the terms of which separate agreement shall govern your use of this material and all supplemental related materials ("Purpose").

In addition, by accessing the enclosed material, you acknowledge and agree that you are required to maintain such material in strict confidence and that your use of such material is limited to the Purpose described above. Although Infor has taken due care to ensure that the material included in this publication is accurate and complete, Infor cannot warrant that the information contained in this publication is complete, does not contain typographical or other errors, or will meet your specific requirements. As such, Infor does not assume and hereby disclaims all liability, consequential or otherwise, for any loss or damage to any person or entity which is caused by or relates to errors or omissions in this publication (including any supplementary information), whether such errors or omissions result from negligence, accident or any other cause.

Without limitation, U.S. export control laws and other applicable export and import laws govern your use of this material and you will neither export or re-export, directly or indirectly, this material nor any related materials or supplemental information in violation of such laws, or use such materials for any purpose prohibited by such laws.

Trademark Acknowledgements

The word and design marks set forth herein are trademarks and/or registered trademarks of Infor and/or related affiliates and subsidiaries. All rights reserved. All other company, product, trade or service names referenced may be registered trademarks or trademarks of their respective owners.

Publication Information

Release: Infor XA 9.1

Publication date: March 8, 2013

To the reader

This book contains the information you need to understand and run this application. The information in this book applies only to Infor ERP XA.

For a complete list of the books in the Infor ERP XA library, see the bibliography included on the XA documentation CD.

Before you begin

Complete the System i education for the basic operating concepts of the System i if you do not have equivalent knowledge.

What this book contains

Chapters 1 and 2 acquaint you with the application.

The next group of chapters describe the options on the Master Menu. For example, Chapter 3 contains information about option 1 of the Master Menu. Each chapter includes information about how to use the displays associated with each option.

The last chapter describes the reports and forms for this application.

The appendices contain information about CAS security area, procedure conflicts, Program Corrective Maintenance (PCM) for all the XA applications using Translation Apply, XA Fix Delivery system, and the Fax Interface.

The glossary defines important terms for this application.

Summary of changes

For this release, the applications added to XA are:

- Accounting Management Plus (AM+) is the Client Architecture that handles the base accounting applications of Accounts Payable, Accounts Receivable, and General Ledger, as well as extensive note taking and improved aging functions. For more detailed information, see the *Accounting Management Plus User's Guide*.
- Advanced Planning Configurator (APC) is the integration of XA and Cameleon products. APC allows you to model possible configurations of your products contained within XA so that you can create customer and sales orders for those items. Both configured items and standard items can be ordered using this integration.

This integration allows you to transfer data from the XA database into Cameleon Visual Expert for modeling. To use APC, you must have EPDM, CSM, and OBPM installed. For more detailed information on APC, see the *Cameleon Integration Guide*.

- Coil Management Solutions (CMS) is a client/server application that consists of four modules:
 - Coil Inventory Manager. This module is the core of the CMS system. It is responsible for all logistical issues surrounding the processing of coils and skids, which includes managing coil and skid characteristics, quality holds, product and process specifications, RF transactions, bar code tags, purchasing specifications, and incoming material quality control.
 - Coil Plant Manger. This module is responsible for processing coils or skids and all related activities including production time tracking and quality data collection. It supports any process that changes the physical dimension, chemical composition or aesthetic appearance of the material.
 - Coil Chain Manager. This module handles the logistics involved in managing Outside Processing, Consignment and Satellite Warehouses.
 - Coil Decisions. This module provides a series of tools, views and reports to help improve decision-making and inventory management in the coil environment. This also includes scheduling, customer claim resolution and supply chain management. Coil Decisions also provides support for defining the building blocks for HFI reports and product specifications. For more detailed information, see the *Coil Management Solutions User's Guide*.
- Contract Accounting Plus (CA+) enhances the XA applications in the contract cost area. CA+ allows you to fully track manufacturing costs associated with every purchase order and shop order, as well as other costs commonly attached to a contract. With CA+, you can analyze cost flows against expected performance and budget. For more detailed information, see the *Contract Accounting Plus User's Guide*.
- FRx FDM 6.0 Installation Instructions for AM and IFM are a financial analysis and reporting tool that allows financial and accounting professionals to streamline processes and generate the financial knowledge necessary to gain a competitive advantage.

Both use the FDM configuration wizard and FDM load wizard to load your AM and IFM general ledger data from their proprietary format into FRx's FDM 6.0 data format. For more detailed information on these applications, see the *FRx FDM 6.0 Installation Instructions for AM* and *FRx FDM 6.0 Installation Instructions for IFM*.

- Product Development Collaboration Magik! (PDCM) is a fully integrated engineering change control solution that allows all members of the product development process to collaborate remotely on product development via the internet. Magik! allows you to create and track a process document throughout its life cycle. It supports:
 - engineering changes
 - new product requests
 - marketing change notification
 - procedural changes
 - production process changes

For more detailed information on Magik! and installation instructions, see the *PDCM! User's Guide*.

- XA System-Link is a bridge between outside systems and XA. An 'outside system' can be a separate platform, such as another ERP system or a web page. It can also be custom code on the same System i. Programs that can format XA System-Link XML requests can initiate transactions with XA. XA System-Link runs its own server and provides the link between a web server and XA EJB server. For more detailed information, see the *System-Link User's Guide*.

Due to the enhancements in the Pick, Pack, and Ship functions in COM, procedure conflicts have been revised in COM, IM, MPSP, CRP and MRP. See "Procedure Conflicts" for these applications.

In the Install/Tailor Application chapter, the following information should also be considered before you begin the installation of XA:

The new environment characters must be unique to XA. The program libraries can be shared with other XA environments as long as they are the same release level. An XA environment cannot share any characters already existing on the system for MAPICS/DB environments.

Changes in text are marked by revision bars.

Contents

To the reader	1-iii
Before you begin	iii
What this book contains	iii
Summary of changes	1-iv
Chapter 1. Introducing Product Data Management	1-1
What Product Data Management does	1-1
How PDM works with other applications	1-1
Product Data Management interfaces	1-2
How the information flows within Product Data Management	1-2
The PDM Main Menu	1-4
Files	1-5
System Control file	1-5
Master files	1-5
Work files	1-7
Master file searches	1-7
Records in use	1-7
Security	1-7
Reports	1-8
Inquiry	1-9
Automated job submission	1-9
Using eWorkPlace with Infor XA documentation	1-10
Chapter 2. Managing Product Data Management	2-1
Before you begin	2-1
Selecting a file update method	2-1
Examining source material	2-2
Establishing accounting controls	2-2
Setting the sequence of operations	2-3
Product Data Management functions and calculations	2-3
Interface considerations	2-4
Item Master file	2-5
Product Structure file	2-6
Production Facility file	2-7
Routing file	2-8
Routing Description file	2-9
Item Foreign Language file	2-10
File summary	2-10
File maintenance for Product Data Management	2-11
Features and options	2-13
Full and selective costing	2-24
Standard batch quantity	2-27
Operation yield	2-28
Roll Current Costs to Standard Costs	2-32
Foreign language descriptions	2-32
Chapter 3. Inquiry	3-1
Prerequisites	3-2
Option 1. Display Item Detail (AMEM02)	3-3
AMVDIM00—Specify Item to Display	3-4
AMVDIM01—Display Item Detail	3-5
Option 2. Product Structure Retrievals (AMEM02)	3-7
AMEC70—Product Structure Retrievals (Select)	3-8

AMEC71—Single Level Bill of Material (Inquiry)	3-10
AMEC72—Indented Bill of Material (Inquiry)	3-13
AMEC73—Single Level Where-Used (Inquiry)	3-16
AMEC74—Single Level Bill With Blow-Through (Inquiry)	3-19
Option 3. Single Level Costed (AMEM02)	3-22
AMEC40—Single Level Costed (Select)	3-23
AMEC41—Single Level Costed—Current (Inquiry)	3-25
AMEC42—Single Level Costed—Standard (Inquiry)	3-29
Option 4. Routing (AMEM02)	3-30
AMED40—Routing Operations (Select)	3-31
AMED41—Routing Operations (Inquiry)	3-32
AMED46—Routing Operation Description (Inquiry)	3-37
Option 5. Production Facility (AMEM02)	3-39
AMVD60—Production Facility Inquiry (Select)	3-40
AMVD61—Production Facility Inquiry	3-41
AMVD62—Production Facility Inquiry—Variable Capacity	3-45
Option 6. Feature/Options (AMEM02)	3-47
AMED80—Feature/Options (Select)	3-48
AMED81—Feature/Options (Inquiry)	3-49
Option 7. Feature/Options with S-Number Build (AMEM02)	3-51
AMVD90—Feature/Options with S-Number Build (Select)	3-52
AMVD91—Feature/Options with S-Number Build (Inquiry)	3-53
Option 8. Item Foreign Language Descriptions (AMEM02)	3-56
Chapter 4. Reports	4-1
Option 1. Item Master Selections (AMEM03)	4-3
AMVE11—Item Master Report (Select)	4-4
Option 2. Production Facility Report—by Facility (AMEM03)	4-6
Option 3. Production Facility Report—by Department (AMEM03)	4-7
Option 4. Feature/Options Report (AMEM03)	4-8
Option 5. Retrieval Selections—Regular (AMEM03)	4-9
AMEF41—Retrieval Selections—Regular—Single List (Select)	4-10
AMEF42—Retrieval Selections—Regular—Multi List (Select)	4-12
AMEF45—Retrieval Selections—Regular—Single List (Select)	4-14
AMEF46—Retrieval Selections—Regular—Single List (Select)	4-16
AMEF47—Retrieval Selections—Regular—Single List (Select)	4-18
Option 6. Retrieval Selection – Costed (AMEM03)	4-20
AMEF43—Retrieval Selections—Costed—Single List (Select)	4-21
AMEF44—Retrieval Selections—Costed—Multi List (Select)	4-23
Option 7. WIP Cost Worksheet (AMEM03)	4-25
AME751—WIP Cost Worksheet (Select)	4-26
Option 8. Item Foreign Language Description (AMEM03)	4-28
AMEPT8—Item Foreign Language Descriptions	4-29
Chapter 5. Costing	5-1
Full and selective costing	5-3
Simulating product cost	5-3
Options 1 — 3. Product Costing—Current/Standard/Both (AMEM04)	5-4
AMEJ78—Product Costing—Both Current and Standard (Select)	5-5
Options 4 — 6. Simulate Product Cost—Current/Standard/Both (AMEM04)	5-7
AMEJ70—Product Cost Simulation (Select)	5-8
AMEJ71—Product Cost Simulation—Change by Item (Select)	5-10
AMEJ72—Product Cost Simulation—Change by Item (Enter)	5-11
AMEJ73—Product Cost Simulation—Change by Item (Review)	5-13
AMEJ74—Product Cost Simulation—Change by Facility (Select)	5-15

- AMEJ75—Product Cost Simulation—Change by Facility (Enter) 5-16
- AMEJ76—Product Cost Simulation—Change by Facility (Review) 5-18
- AMEJ77—Product Cost Simulation—Change by Percent (Enter) 5-20
- Option 7. Item Cost Percent Change (AMEM04) 5-23
 - AMET50—Item Cost Percent Change—Percent Change of Material by Item Class (Chang%) 5-24
- Option 8. Change L/O Costing Table (AMEM04) 5-26
 - AMVX71—Labor/Overhead Table (Change) 5-27
- Option 9. Change L/O Simulation Costing Table (AMEM04) 5-29
 - AMVX71—Labor/Overhead Table (Change) 5-30
- Option 10. Change P/O Costing Table (AMEM04) 5-31
 - AMVX72—Purchase Overhead Table (Change) 5-32
- Option 11. Change P/O Simulation Costing Table (AMEM04) 5-34
 - AMVX72—Purchase Overhead Table (Change) 5-35
- Option 12. Roll Current to Standard Costs (AMEM04) 5-36
 - AME4601—Roll Current to Standard Costs (Confirm) 5-37
- Chapter 6. File Maintenance** 6-1
 - Overview 6-3
 - Conflicts 6-3
 - Option 1. Item Master (AMEM05) 6-4
 - AMVT01—Item Master File Maintenance (Select) 6-6
 - AMVT02—Item Master File—General Information (Add/Change/Delete/Set Defaults) 6-9
 - AMVT03—Item Master File—Additional Information (Add/Change/Delete/Set Defaults) 6-15
 - AMVT04—Item Master File—Costing Information (Add/Change/Delete/Set Defaults) 6-18
 - AMVT05—Item Master File—Purchasing Information (Add/Change/Delete/Set Defaults) 6-23
 - AMVT06—Item Master File Maintenance (Status) 6-27
 - Option 2. Product Structure (AMEM05) 6-28
 - AMEUA1—Product Structure File Maintenance—Data Entry Control 6-29
 - AMEU11—Product Structure File Maintenance (Select) 6-32
 - AMEU12—Product Structure File Maintenance (Add/Review) 6-35
 - AMEU13—Product Structure File Maintenance (Change/Review) 6-40
 - AMEU14—Product Structure File Maintenance (Mass Replace/Review) 6-42
 - AMEU15—Product Structure File Maintenance (Delete/Review) 6-44
 - AMEU16—Product Structure File Maintenance (Mass Delete/Review) 6-46
 - AMEU17—Product Structure File Maintenance (Structure Delete/Review) 6-49
 - AMEU18—Product Structure File Maintenance (Batch Status) 6-51
 - AMEU31—Product Structure File Maintenance (SAE Header) 6-53
 - AMEU32—Product Structure File Maintenance (SAE Change) 6-56
 - AMEU33—Product Structure File Maintenance (SAE Delete) 6-58
 - AMEU34—Product Structure File Maintenance (SAE Add) 6-60
 - AMEU35—Product Structure File Maintenance (Batch Status) 6-62
 - AMEU41—Product Structure File Maintenance (Review) 6-64
 - AMEU42—Product Structure File Maintenance (Review) 6-66
 - AMEU43—Product Structure File Maintenance (Batch Status) 6-69
 - AMEUG1—Product Structure File Maintenance (Review) 6-71
 - Option 3. Production Facility (AMEM05) 6-73
 - AMVT70—Production Facility Maintenance (Select) 6-74
 - AMVT71—Production Facility Maintenance (Add) 6-76
 - AMVT72—Production Facility Maintenance (Change) 6-81

AMVT73—Production Facility Maintenance (Delete)	6-82
AMVT74—Production Facility Maintenance (Change)	6-83
AMVT75—Production Facility Maintenance (Status)	6-85
AMVTC1—Variable Capacity Maintenance (Select)	6-87
AMVTC2—Variable Capacity Maintenance (Add)	6-89
AMVTC3—Variable Capacity Maintenance (Change)	6-92
AMVTC4—Variable Capacity Maintenance (Delete)	6-94
AMVTC5—Variable Capacity Maintenance (Delete All)	6-96
AMVTC6—Variable Capacity Maintenance (Status)	6-98
Option 4. Routing (AMEM05)	6-100
AMEU61—Routing File Maintenance Data Entry Control	6-101
AMEU71—Routing File Maintenance (Select)	6-104
AMEU72—Routing File Maintenance (Add/Review)	6-106
AMEU73—Routing File Maintenance (Change/Review)	6-112
AMEU75—Routing File Maintenance (Delete)	6-114
AMEU76—Routing File Maintenance (Routing Delete)	6-116
AMEU77—Routing File Maintenance (Batch Status)	6-118
AMEU78—Routing File Maintenance (Update)	6-121
AMEU79—Routing File Maintenance (MS-MAINT)	6-123
AMEU21—Routing File Maintenance (SAE Header)	6-125
AMEU22—Routing File Maintenance (SAE Change)	6-129
AMEU23—Routing File Maintenance (SAE Delete)	6-131
AMEU24—Routing File Maintenance (SAE Add)	6-133
AMEU26—Routing File Maintenance (Batch Status)	6-135
AMEU27—Routing File Maintenance (SAE Addl Desc Maint)	6-137
AMEU28—Routing File Maintenance (SAE MS-MNT)	6-140
AMEU81—Routing File Maintenance (Review)	6-142
AMEU82—Routing File Maintenance (Review)	6-144
AMEU83—Routing File Maintenance (Batch Status)	6-148
AMEU84—Routing File Maintenance (Review)	6-150
AMEU85—Routing File Maintenance (Review)	6-152
AMEUK1—Routing File Maintenance (Review)	6-154
Option 5. Item Base Price (AMEM05)	6-157
How to start Item Base Prices	6-157
In Customer Order Management	6-157
In Product Data Management	6-157
Example: Item Base Prices	6-157
Option 6. Item Foreign Language Description (AMEM05)	6-162
How you start Item Foreign Language Description	6-162
In Customer Order Management	6-162
In Product Data Management	6-162
Example: Item Foreign Language Description	6-162
Option 7. Code Files (AMEM05)	6-167
How you start code file maintenance	6-167
Code file maintenance panels	6-168
Example: maintain code files	6-175
Option 8. Offline Maintenance (AMEM05)	6-180
Option 1. Item Master (AMEM55)	6-181
AMVPOF—Item Master Offline Maintenance Options	6-182
Option 2. Product Structure (AMEM55)	6-184
AMVPOF—Product Structure Offline Maintenance Options	6-185
Option 3. Production Facility (AMEM55)	6-186
AMVPOF—Production Facility Offline Maintenance Options	6-187

Option 4. Routing (AMEM55)	6-188
AMVPOF—Routing Offline Maintenance Options	6-189
Option 9. PDM Control File Maintenance (AMEM05)	6-190
AMDPDM1—Control File Maintenance	6-191
AMDPDM2—Control File Maintenance	6-192
AMDPDM3—Control File Maintenance	6-193
Chapter 7. Yield calculation	7-1
Option 1. Calculate Cumulative Yield (AMEM06)	7-2
Option 2. Calculate Adjusted Quantity Per (AMEM06)	7-3
Chapter 8. Report descriptions	8-1
Item Master File Maintenance (AMVT0)	8-3
Item Master File Report—Brief (AMVE40)	8-15
Item Master File Report—Complete (AMVE41)	8-18
Item Master File Report—Current Costs Sequenced By Item (AMVE42)	8-20
Item Master File Report—Purchase Item Detail (AMVE43)	8-22
Item Master File Report—Purchase Item Description (AMVE44)	8-24
End-Item Where-Used (AMEF75)	8-25
Feature/Options Report (AMEF1)	8-27
Indented Bill (AMEF72)	8-30
Product Structure Transaction List (AMEU5)	8-32
Single Level Bill with Blow-Through (AMEF71)	8-35
Single Level Where-Used (AMEF74)	8-37
Summarized Bill (AMEF73)	8-38
Production Facility Maintenance (AMVT7)	8-39
Production Facility Report (AMV43)	8-44
Production Facility Where-Used (AMEG12)	8-48
Variable Capacity File Maintenance (AMVTC)	8-51
Routing and Single Level Retrieval with Blow-Through (AMEG4)	8-52
Routing List (AMEG11)	8-57
Routing Transaction List (AMEU9)	8-59
Cost Variations—Current to Standard (AMEH8)	8-61
Indented Cost Sheet—Current or Standard (AMEG72)	8-64
Management Cost Summary—Current or Standard (AMEH7)	8-67
Operations Cost Sheet—Current or Standard (AMEH41 and AMEH42)	8-69
Product Cost Update Report—Current or Standard Costs (AMEI30)	8-73
Product Cost Simulation—Current and Standard Costs or Average Costs After Change By Percent (AMEI31)	8-75
Single Level Cost Sheet—Current or Standard, Single or Multi-Item, with or without Blow-Through (AMEG71)	8-78
Work-in-Process Cost Worksheet—Current, Standard, or Average Costs (AME86) 8-82	
Calculate Cumulative Yield (AME78)	8-87
Calculate Adjusted Quantity Per (AME82)	8-90
Chapter 9. Forms	9-1
Item Master file maintenance—general information (PM-01)	9-3
Item Master file maintenance—additional information (PM-02)	9-4
Item Master file maintenance—costing information (PM-03)	9-5
Item Master file maintenance—purchasing information (PM-04)	9-6
Item Master offline file maintenance—A-record (PM-26A)	9-8
Item Master offline file maintenance—A-record (PM-26B)	9-9
Item Master offline file maintenance—B-record (PM-27)	9-11
Item Master offline file maintenance—C-record (PM-28)	9-13

Labor/Overhead Table—Change Entry (PM-13)	9-15
Product Structure File Maintenance (PM-14)	9-16
Product Structure Offline Maintenance (PM-15)	9-18
Example of how to build a bill of material	9-19
Purchase Overhead Table—Change Entry (PM-16)	9-29
Routing File Maintenance (PM-17)	9-31
Routing File Milestone Group Maintenance (PM-18)	9-33
Routing Description File Maintenance Additional Operation Descriptions (PM-21)	9-35
Routing File Offline Maintenance (PM-29)	9-37
Production Facility Maintenance (PM-23)	9-39
Production Facility Offline Maintenance (PM-30A)	9-41
Production Facility Offline Maintenance (PM-30B)	9-42
Variable Capacity Master File Maintenance (TM-01)	9-44
Chapter 10. Accounting controls and audits	10-1
Item Master edit/load	10-1
Product structure edit/load	10-4
Routing edit/load	10-5
Production Facility edit/load	10-7
Item Master file maintenance	10-9
Product structure file maintenance	10-10
Production facility file maintenance	10-12
Variable capacity file maintenance	10-13
Routing file maintenance	10-14
Product structure file reorganization	10-17
Routing file reorganization	10-18
Routing description file reorganization	10-19
Percent changes	10-20
Appendix A. Offline file load and data entry	A-1
Gathering the information	A-1
Creating an offline file	A-1
File format	A-1
File name	A-2
Viewing and printing file record layouts	A-2
Entering data into offline files	A-2
Special data requirements	A-3
Loading offline files into PDM	A-3
Processing offline files	A-4
Entering changes and deletions	A-4
Item Master (ITMDKT) file	A-6
Record type A: Item information (IMDSKTA)	A-7
Record type B: Costing information (IMDSKTB)	A-7
Record type C: Purchasing information (IMDSKTC)	A-7
Routing file (RTGDKT)	A-8
Scheduling specific work centers	A-8
Product Structure file (PSDSKT)	A-11
Production Facility file (PFDSKT)	A-12
Appendix B. Security areas	B-1
Appendix C. Information retrieval and calculations	C-1
Retrieval logic	C-1
Single level explosion routine	C-1
Indented explosion routine	C-1
Summarized explosion routine	C-1

Single level explosion with blow-through routine	C-1
Single level implosion routine	C-2
End-item where-used routine	C-2
Routing routine	C-2
Production Facility where-used routine	C-2
Low-level codes	C-3
Level tables	C-3
Product structure continuity checking	C-4
Cost calculations	C-6
Cost formula used for material	C-7
Source of data used in Material cost calculations	C-7
Cost formulas used when cost technique code=T	C-7
Cost formulas used when cost technique code=R	C-7
Source of data used in Labor and Machine cost calculations	C-8
Labor and Machine Costs	C-8
Source of data used in Labor and Machine cost calculations	C-9
Manufacturing Overhead	C-10
Source of data used in Manufacturing Overhead calculations	C-11
Outside operations	C-11
Source of data used in outside operations calculations	C-12
Outside operation cost calculations	C-12
Cost roll-up logic	C-12
Feature/options handling (includes discussion of phantoms)	C-13
Features vs. Phantoms	C-14
Appendix D. Automated job submission for PDM	D-1
Command guidelines	D-1
Application APIs	D-2
OLMITM - Offline Item Maintenance	D-3
Purpose	D-3
Optional Parameters	D-3
OLMPST - Offline Product Structure Maintenance	D-4
Purpose	D-5
Optional Parameters	D-5
OLMRTG - Offline Routing Maintenance	D-6
Purpose	D-6
Optional Parameters	D-6
Glossary	GL-1
Index	IN-1

Chapter 1. Introducing Product Data Management

This chapter contains general information you need to know about what Product Data Management does and how it works with other XA applications.

What Product Data Management does	1-1
How PDM works with other applications	1-1
How the information flows within Product Data Management	1-2
Files	1-5
Records in use.....	1-7
Security.....	1-7
Reports	1-8
Inquiry.....	1-9
Automated job submission	1-9
Using eWorkPlace with XA documentation	1-10

Some concepts and features that are common to most of the XA applications are discussed in two other books: *Getting Started with Infor ERP XA* and *Planning and Installing Infor ERP XA*.

- Menus and displays
- Group Job support
- Master file searches
- Audits and controls
- Security.

What Product Data Management does

Product Data Management (PDM) organizes, maintains, and presents the basic data for a manufacturing organization. This data includes information about inventory—raw materials, purchase parts, subassemblies, and assemblies in structural parent/component relationships. The data also includes information about your production facilities and the sequence of standard operations used to build products. Foreign language item descriptions are also included in this data.

You can load records to the master files from offline and you can add, delete, or change them through work stations or offline file maintenance. Cost buildup reports are printed and cost fields in the master files are updated. Product yields and adjusted quantity per are kept current by running the cumulative yield and adjusted quantity per calculations. Reports are retrieved from the centralized data base files.

How PDM works with other applications

Several XA applications use information stored in Product Data Management (PDM) master files.

Beginning with Release 6, when EPDM is activated, EPDM becomes solely responsible for maintaining items, bills (product structures), routings, and facilities. At this point, the PDM application ceases to exist. However, the PDM item master files are retained and used by applications that have not been interfaced with EPDM. These item master files (ITEMASA, B, and C) are automatically maintained by EPDM as changes are made to any EPDM item revision master record released to PDM. All

applications that used the PDM product structure, routing, and facility files have been integrated to use the corresponding files in EPDM.

The following table shows the flow of information between Product Data Management and other XA applications.

Product Data Management interfaces

PDM sends information to ...

- COM** Usage of standard features/options, tax codes, and item master information.
- CRP** Standard routing and production facility and variable capacity calendar.
- IM *** Product structure and costing information; item master information.
- MPSP*** Product structure, production facility, and item characteristics.
- MRP*** Product structure and item characteristics.
- PC&C*** Production facility costing and routing information.
- PUR** Routing information.
- REP*** Production facility information; routing information; bill of material information; variable capacity calendar.
- SA** Item master information.

* Handled by EPDM if EPDM is activated.

PDM receives information from ...

- EPDM** If activated, automatically updates item master records with the same updates made in EPDM.
- PC&C** Work center statistics and average operation hours in routing
- REP** Average yield routing information.
- PDMPPlus** Offline file load transactions for item, routing, and product structure master files.

How the information flows within Product Data Management

After the files have been loaded, you can request inquiries or reports or do file maintenance to those files through the work stations.

If you selected product costing during application tailoring, you must do a full or selective costing run, before any costed reports or inquiries are requested. You run cumulative yield and adjusted quantity per calculations to keep Costing, MRP planning, and Order Release information current.

As you need them, you can print the Item Master File Report, Production Facility Report, bills of material, routings, where-used lists, Feature/Options Report, Work-in-Process Cost Worksheet, and Item Foreign Language Descriptions Report or Items W/O Foreign Language Descriptions Report.

Figure 1-1 shows how information flows through the Product Data Management application.

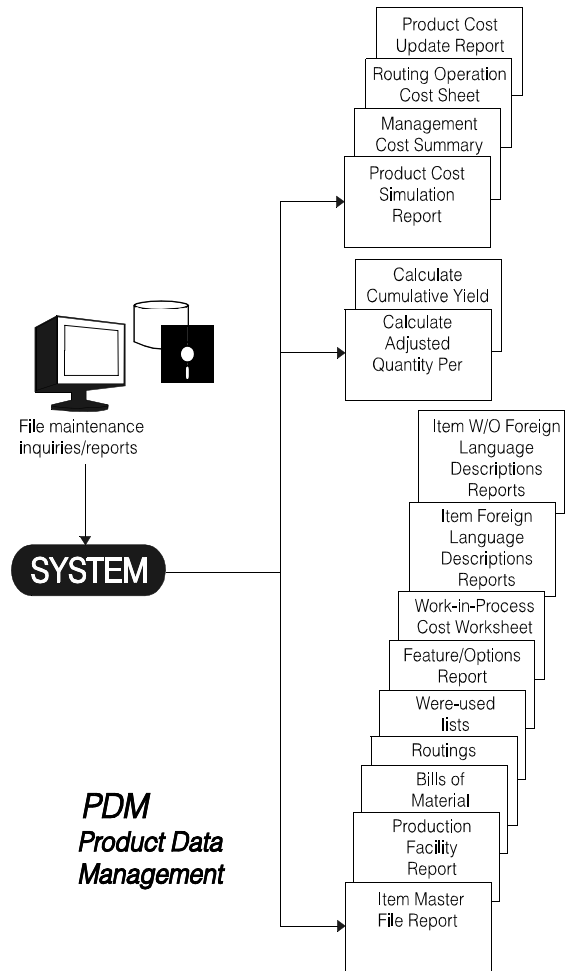

Figure 1-1. Flow of information in Product Data Management

The PDM Main Menu

```
AMEM00                                Product Data Management          **
*****                                Main Menu

Type option or command; press Enter.

1. Inquiry >>
2. Reports >>
3. Costing >>
4. File Maintenance >>
5. Yield Calculation >>
```

Option 1. Inquiry. Used to view information about items, routings, facilities, features and options, product structures, and foreign language descriptions.

Option 2. Reports. Used to establish limits and print reports about items, facilities, features and options, product structures, and foreign language descriptions.

Option 3. Costing. Used to print product costing reports or simulated product costing reports using standard or current costs, or both.

Option 4. File Maintenance. Used to add, change, delete, or set session defaults for the Item Master, Product Structure, Production Facility, Routing, Routing Description, Item Base Price, Item Foreign Language, and Code Table files, to perform offline file maintenance and to maintain the data in the PDM Control file.

Option 5. Yield Calculation. Used to calculate cumulative yield and adjusted quantity per.

If EPDM is activated, this menu is disabled, and maintenance must be performed in EPDM.

You may have a question about the menus or displays while running the application. If you press the Help key, the display changes to a Help display with information about menu options or about the fields and function keys on the displays.

Files

Three kinds of files are described in this chapter— the System Control file, master files, and work files.

System Control file

The System Control file (SYSCTL) provides a place to store relatively unchanging information that is used by more than one procedure or program.

Among the important contents of the System Control file are:

- Control information needed to run your application (dates, limits, percentages, ranges, rates, and so on)
- Application tailoring options.

Master files

Unlike work files, the master files are permanently stored on your system. Most information in the Product Data Management application is held in nine master files that are created during installation. The permanent PDM files are:

- Item Base Price (MBBZREP)
- Item Foreign Language (ITMLAN)
- Item Master (ITEMAS)
- PDM Control file (PDMCTL)
- Product Structure (PSTRUC)
- Production Facility (WRKCTR)
- Routing (ROUTNG)
- Routing Description (RTGDSC)
- Variable Capacity (CAPVRY).

In addition, there are two permanent files that store maintenance transactions until the batches for the Product Structure, Routing, and Routing Description files are released for batch update. They are:

- Product Structure Transaction Maintenance file (PSMANT)
- Routing Transaction Maintenance file (RTMANT).

Note: If EPDM is activated, the Product Structure, Production Facility, Routing, and Routing Description files are no longer available. These files are replaced by corresponding files in EPDM.

Item Base Price file

The Item Base Price file contains base price, pricing unit of measure, item price class, and effective date information for items in the Item Master file.

Item Foreign Language file

The Item Foreign Language file contains item description records in specified foreign languages for items that you select for foreign descriptions. You set up the foreign language description records so that each description matches a specific item number and language code combination. The Item Foreign Language file is also used by Customer Order Management.

Item Master file

The Item Master file contains at least two records, the A-record and the A-record extension, for each unique item number. The A-record has general item information. The general item information includes fields such as item description, item type, stocking unit of measure, standard batch quantity, and total cumulative yields. The A-record extension contains additional general item information such as commodity code, warranty period, unit of measure, commission percent and tax information.

The Item Master file has a B-record associated with the A-record (and A-record extension) for each item when you select any of the following:

- Product costing during application tailoring
- Full version of Material Requirements Planning (MRP) is installed and interfacing
- Master Production Schedule Planning (MPSP) is installed and interfacing.

The B-record contains costing information, such as standard lot size and cost technique code.

If Purchasing is installed, the Item Master file can have a C-record for each item. The C-record is optional (except for Item Types 3 or 4), and has Purchasing information such as buyer number, vendor performance, and average order size.

PDM Control file

The PDM Control file contains user-set options that control certain PDM costing functions, as well as the default site identifier to use when EPDM is interfacing. This file is in addition to the PDM tailoring questions found in the tailoring function.

Product Structure file

The Product Structure file contains one record for each parent/component relationship in a user's bill of materials. Each record includes information such as the quantity of a component required to produce one standard batch quantity of the parent item, and effective-from-and-to dates for engineering changes.

Production Facility file

The Production Facility file contains one record for each production facility in the manufacturing area with information such as department, foreman, and queue times. Each record also contains efficiencies, current and standard rates, such as setup labor, which are used in product costing.

Routing file

The Routing file records contain the standard sequence of operations specified by item. Each record also has standard hours per unit for each operation, which are used by product costing.

Routing Description file

The Routing Description file records contain expanded descriptions about the operations specified for an item.

Variable Capacity file

The Variable Capacity file contains records representing production facility capacity variations due to factors such as vacations, temporary help, resource shifted between production facilities, overtime, scheduled downtime or new facilities coming online. You can temporarily change the capacity of a production facility by using Production Facility Variable Capacity file maintenance. When Capacity Requirements Planning (CRP) or Repetitive Production Management (REP) are installed, the work loads they schedule, are compared against the actual capacity available during the period. This comparison can also include the variable capacity.

Work files

Work files are files created by PDM to hold information for processing. These files include:

- Costing Work file (partial Item Master file) (COSTWK)
- Product Structure Extract file (PSEXTR)
- Product Structure Transaction Update file (PSUPDT)
- Routing Transaction Update file (RTUPDT)
- Simulation Transactions file (SIMXAC).

You cannot directly alter these files.

Master file searches

XA has master file searches that you can use to look up information in various master files. To begin a search, type a question mark (?) in a field that supports searching.

After you type a question mark in an eligible field, use **FIELD EXIT** and then press **Enter**. A display appears on which you describe the type of search you want and what you want to find.

Records in use

If a record in use error occurs, you are shown a message indicating that the requested record is in use. You can resolve the problem by selecting a different record for file maintenance or performing some other task until the record you want to maintain is no longer in use by someone else. After you have resolved the problem, you need to enter the changes for the record that was on display when the records in use message occurred.

Security

Security is provided for the following Product Data Management functions (see Appendix B, "Security areas"):

- Inquiry and reports.
- File maintenance for the Item Base Price, Item Foreign Language, Item Master, PDM Control, Product Structure, Production Facility, Routing, Routing Description, and Variable Capacity files.

- Costed information with a secondary security check for inquiry and reports; for example, costed inquiry has two security checks.
- Pricing information.
- Product costing, including simulation and table maintenance for the Labor/Overhead and Purchase Overhead Tables.

These safeguards are designed to prevent unauthorized access to master files, reports, and processing functions. For more information on how to activate and use security, see the *CAS User's Guide*.

Note: XA includes an optional security system called Personal Menu Maintenance. See the *CAS User's Guide* for more information.

Reports

Product Data Management offers report options you can use to get reports for selected information. See Chapter 8, "Report descriptions" for more detail.

The major reports printed by this application are:

- Item Master File Report—Complete shows all important information for all items within limits in item sequence specified on the selection screen. You can select to print by item type, by item within vendor, by item within buyer, by item within item class, by item within item accounting class, or by item.
- Item Master File Report—Brief prints one line per item, showing basic information for all items requested within limits in item sequence. As with the complete list, you can select to see this report by item within item type, by item within vendor, by item within buyer, by item within item class, by item within item accounting class, or by item.
- Item Master File Report—Current Costs or Standard Costs prints limited general item and item cost information.
- Production Facility Report by Facility shows all important information for your facilities.
- Production Facility Report by Department shows all important information for your facilities organized by facility within department.
- Single Level Bill shows one level of the bills of material (structural relationships) for all items or a range of items (multi-list report) or for a single item (single list report).
- Indented Bill shows the entire bill of material (structural relationship) in indented format for all items or items within limits (multi-list) or for a single item (single list).
- Summarized Bill shows the entire bill of material (single list) for an item summarized as a parts list.
- Single Level Where-Used shows all the parent items (one level up) directly using an item.
- End Item Where-Used shows all the end items using an item. You can select a single list report to see all the end items using one component, or a multi-list report to see all items that have parents. For multi-list, you can also select all items or a range of items.
- Single Level Routing List shows the standard sequence of operations required to make the products.

- Feature/Options Report shows all the options of all the features for all end items.
- Work-in-Process Cost Worksheet shows the standard, current, and average costs for some or all items.
- Item Foreign Language Report has 2 options:
 1. Prints the Items With Foreign Language Descriptions report.
 2. Prints the Items Without Foreign Language Descriptions report, showing the language code, item number, item description, and item class for items that do not have a description set up in the specified language code.

Inquiry

During daily operations, situations may occur that require a prompt, convenient way of retrieving information. You can inquire into the status of any item, production facility, routing operation, product structure, or foreign language description on file.

The kinds of information that can appear include:

- Item information
- Item Foreign Language information.
- Features and options
- Indented bill of material
- Production Facility information
- Routing information
- Single level bill of material
- Single level costed
- Single level where-used
- Single level with blow-through

Automated job submission

XA provides the ability to execute batch jobs from outside of the XA menu structure for Product Data Management (PDM) application tasks listed below:

Task	Menu and option
Item Master Offline Maintenance	AMEM55-01 and AMIM7E-01
Product Structure Offline Maintenance	AMEM55-02
Routing Offline Maintenance	AMEM55-04

XA provides the necessary architecture modules to enable application tasks to be initiated from sources other than the XA menu system and to be initiated in a batch subsystem. In order to provide the most flexibility, the Cross Application Support (CAS) portion of this activity is done using a series of Application Program Interfaces (APIs). The end user cannot execute these APIs at a System i command line; they must be called by a batch or interactive program.

Refer to Appendix D, "Automated job submission for PDM" for more information on the APIs.

Using eWorkPlace with XA Documentation

eWorkPlace (eWP) is the Microsoft®, Windows™-based graphical user interface for XA. The eWP windows co-exist with the XA character-based displays, called Host screens. If you are using eWP, you can view the corresponding Host screen for any eWP window, if necessary.

Note: If you have modified a Host screen, the GUI default is used. The default GUI feature can be enabled or disabled.

The user’s guides and help text contain instructions that reference the host XA screens (called panels and displays) rather than the eWP windows.

To understand how a Host screen instruction relates to an action on a eWP window, it is helpful to look for text on a window control that corresponds to the instruction. For example, **Cancel** on a button and on a File pull-down corresponds to the user guide instruction “use **F12=Cancel** to return to the previous display”.

Note: For the instruction “press **Enter**”, the corresponding control on a eWP window is an **OK** button.

The following table shows other examples of instructions from the documentation and the corresponding actions you take on the eWorkPlace window.

Documentation instructions	eWorkPlace actions
To change the details of a vendor, type 2 next to the vendor and press Enter .	Select a vendor, then select Change or type C from the List menu or select Change using the right mouse. Click the OK button.
To create a vendor, use F6 .	Select Create on the Functions menu or click the Create button.
Position to command. If you want to skip to a particular command, type the full or partial command.	Type the full or partial command in the position to entry field and click the Position button.
Type the information requested and press Enter .	Type values in or select values for the entry fields and click the OK button.
Type the information requested and use a function key.	Type values in or select values for the entry fields and click a button or select an action on the Functions pull-down.
Use the Item Master maintenance display to.....	Use the Item Master maintenance window to.....

For more information about eWP, see *Getting Started with eWorkPlace*.

Chapter 2. Managing Product Data Management

Before you begin	2-1
Product Data Management functions and calculations	2-3

Before you begin

Before you begin Product Data Management operations, you need to analyze the tasks associated with the PDM application. The tasks include:

- Selecting a method or combination of methods to use for updating your files.
- Examining the source material you receive and determining how to group this information to update master files.
- Establishing the accounting controls you want to use and determining who is responsible for applying them.
- Setting the sequence of actions taken when implementing PDM.

Selecting a file update method

If you are just implementing, data can be loaded via offline file maintenance. The system accepts information entered directly from a work station. When you update your Product Structure or Routing files using file maintenance at a work station, you can select immediate update (UPDATE NOW) or batch update (CLOSE BATCH). You must decide which method or combination of the two is best for your operation. Item Master and Production Facility files can also be updated at a work station. You can update the Item Master, Production Facility, Product Structure and Routing files using offline file maintenance.

File maintenance for Product Structure and Routing files in PDM is done using a batch transaction file. When you sign on at a work station and select file maintenance, a data entry control display appears. This display shows the status of any existing transaction batches. The status can be ACTIVE, CLOSED, SUSPND (suspended), UPDATE, FINISH, or DELETE (see the following display image). You can work on an active batch only from the same work station used to enter the transactions, but you can work on suspended batches regardless of their originating work station. To start a new batch, you use **F04** (if available batches exist). To update an existing batch, you enter its corresponding batch number.

ENTER BATCH NUMBER		ROUTING FILE MAINTENANCE DATA ENTRY CONTROL				BATCHES CURRENTLY IN USE LOCATE BATCH		
BATCH NO.	WSID	OPID	WSID	OPID	STATUS	DATE	RECORDS USED	
452	B444444444	GMC	B222222222	GMC	ACTIVE	08/10	11	
453	B444444444	ABM	B444444444	ABM	ACTIVE	08/09	11	
456	B444444444	HDE	B444444444	HDE	CLOSED	08/08	50	
457	B444444444	GMC	B444444444	GMC	SUSPND	08/07	89	
458	B555555555	ABM	B555555555	ABM	FINISH	08/06	89	
459	B555555555	HDE	B555555555	HDE	UPDATE	08/05	78	
460	B222222222	RWF	B222222222	RWF	DELETE	08/04	11	
461	B555555555	GMC	B555555555	GMC	ACTIVE	08/03	11	
462	B666666666	ABM	B222222222	ABM	ACTIVE	08/02	89	
463	B666666666	HDE	B666666666	HDE	CLOSED	08/01	89	
464	B666666666	RWF	B222222222	RWF	ACTIVE	07/24	78	
465	B666666666	GMC	B555555555	GMC	SUSPND	07/25	11	
466	B777777777	ABM	B444444444	ABM	DELETE	07/26	11	

USE ROLL UP/DOWN
 F04 NEW BATCH
 F24 CANCEL JOB

If you answered Y to question X02 of the CAS questionnaire, the batches are available for use after a batch is released and used for update. This means that if the system has to be restored (because of power or system failure) from a saved copy of the files (from the last backup), the transactions must be reentered. The advantage to this approach is that the batches may be reused after every update. The disadvantage is that if a power or system failure occurs, the data in those files is not recoverable. You must enter all transactions again and rerun the updates to recover your system. If you answer Y to question X02, you should back up your files at least once a day.

If you answered N to question X02, the batches are not made available when a batch is completed. The batch status=finished, but the files are retained until the next backup and can be used for recovery. The transaction file is cleared of the finished batches only when the system is backed up. This means that you do not have to reenter the transactions if the system has to be recovered from saved files.

Examining source material

Efficient entry requires that all information you need is readily available in the source material. You may want to review the displays in file maintenance or the data entry forms in Chapter 9 "Forms" to determine what information is required. You should also review the ways transactions come in to determine if all the necessary information is available to you. If transactions come in on your own form, you can allow space for entering any additional information you need. Decide how all this material is handled and how missing information is supplied. See "Product Data Management functions and calculations" to determine what data you need to gather.

Establishing accounting controls

Controls are critical to your business for maintaining efficiency and guarding against erroneous information. For example, session statistics can be verified when the Item Master, Product Structure, Routing, Production Facility, Routing Description, or Item

Foreign Language files are loaded or maintained. See Chapter 10, "Accounting controls and audits" to understand how to check these totals and audit trails.

Also, your operating procedures should include using Inquiry displays and other features of the application to check the information being entered or already on file.

Setting the sequence of operations

The overview of PDM in this book, as well as the explanations in other XA manuals of how to use PDM, help you determine how and when to use the operations associated with the PDM application. In some cases, only one sequence of operations is acceptable. In others, a choice is available, but one order of operation may be more desirable than another. For example, the addition of records to the Item Master file must be done before other operations of PDM. (If IM or COM is installed and interfacing, the Item Master file is already in the system.) Then, anytime after you load the files, you can run reports, make inquiries into the status of information contained in these files, and perform file maintenance when any specific data must be updated or added. Examples of other operations are: maintaining records using data entry forms, costing products, structuring bills of material, and calculating operation yield.

Product Data Management functions and calculations

To make better judgments concerning your operations and your answers to the PDM questionnaire, you need to understand some of the functions and calculations of the PDM application.

You can select optional functions when you answer the PDM questionnaire. You also can define certain product costing functions in the PDM Control file, using option 9 on the File Maintenance menu.

You should read Appendix C, "Information retrieval and calculations" for detailed information on PDM's costing formulas.

Interface considerations

Although you answer the PDM questionnaire before loading your files, you have to make some decisions concerning your files before answering the PDM questionnaire. The following is a discussion of application interfaces associated with PDM, as well as information relating to some of the master files.

The following table describes what to expect when EPDM is activated and the applications shown are enabled to EPDM.

Table 2-1. Differences when applications are enabled to EPDM

Application	Description
IM	The IM functions of manufacturing order processing (Entry, Release, Close) are enabled to a site based on the warehouse specified for the order. At the time of order entry, a user can elect to override a default item process that is effective on the order's start date.
MPSP	All MPSP functions are enabled to the site for the planning warehouse being processed. An item's primary process is stored with the planned order when it is created. Changing a planned order's process automatically firms the order.
MRP	All MRP functions are enabled to the site for the planning warehouse being processed. An item's primary process is stored with the planned order when it is created. Order review allows changing of an item process prior to the release.
PC&C	The PC&C function of manufacturing order entry is enabled for the site based on the warehouse specified for the order. Manually entered routings or a routing from an IM released item process can be entered automatically.
PDM	EPDM is the only source of maintenance for PDM's item master records (Item Master, Product Structure, Production Facility, and Routing) when it is activated. If EPDM is activated, PDM is disabled.

The following discussion provides information about PDM interfaces when EPDM is not activated.

- Inventory Management (IM) requires nothing from PDM, but, if PDM is installed and interfacing, IM uses the Product Structure file to create the manufacturing order (data) records. IM also uses the PDM features and options function, if you choose it when answering the PDM questionnaire. If PC&C is installed and interfacing, IM can use the Production Facility and Routing files during manufacturing order release.
- Master Production Schedule Planning (MPSP) requires the Item Master, Product Structure, Production Facility, and Routing files. PDM is a prerequisite for MPSP, which uses information from the Item Master file. MPSP uses the Product Structure file for master schedule planning, resource planning generations, and determining the parent/component relationships in an item's bill of material. MPSP uses the Routing and Production Facility files for resource planning generation. This information is used to identify critical machine or labor resources and allows MPSP to calculate when and how much of that resource (timing, quantity, and cost) each item uses.
- PC&C requires nothing from PDM but uses the Routing and Routing Description files to create manufacturing order routing records if PDM is installed with Routing. Routing description Order records are placed in the Manufacturing Order Description file if this option is supported by PDM and was selected during PC&C application tailoring. PC&C also updates averages in the Routing and Production Facility files when manufacturing orders are closed and purged.

- Production Monitoring and Control (PM&C) uses routing and production facility data supplied by PDM through PC&C. If PDM is installed and interfacing with PM&C, then PM&C uses PDM Production Facility Inquiry and File Maintenance.
- Repetitive Production Management (REP) requires the Production Facility, Routing, and Product Structure files. REP needs information from these files to release schedules and items for manufacture. PDM is a prerequisite for REP.
- Purchasing (PUR) uses the Routing file for receiving operations information. PUR requires the Item Master files, and expands the amount of purchase information retained for an item.
- Capacity Requirements Planning (CRP) requires the Production Facility file from Production Control and Costing (PC&C). This file is optional for PDM. To use this file from PDM, you must select it when answering the PDM questionnaire. CRP also uses the Routing file to obtain operations to load against production facilities during the CRP planning run.
- Forecasting (FCST) uses the Item Master file to generate forecast/projection quantities and forecast/requirements, and to classify and load requirements to MPSP or MRP for master level items.
- Material Requirements Planning (MRP) and Repetitive Production Management (REP) require the Item Master and Product Structure files. PDM is a prerequisite for Material Requirements Planning and Repetitive Production Management.
- Customer Order Management (COM) requires nothing from PDM but uses the Product Structure file for end items with options, if PDM is installed and interfacing. COM also uses the Item Master file, and Item Foreign Language file.
- The XA PDM application is a prerequisite to *PDMPlus*. *PDMPlus* uses the offline file maintenance capabilities of PDM and other applications to perform updates to bill, routing, and item files. The key features for *PDMPlus* are:
 - Creating item master and item balance offline transaction records at the same time.
 - Creating mass maintenance transactions. Change classifications, adjust lead times, modify cost content, and much more on any group of items that can be identified through an associative process.

When EPDM is activated, EPDM becomes solely responsible for maintaining PDM's item master files.

Item Master file

The Item Master file is a required file for PDM. If Inventory Management (IM) or Customer Order Management (COM) is installed and interfacing, this file is already in your system. If the Item Master file is in your system, you may want to add information to it. If the file is not in your system, the Item Master file is created during application tailoring.

The Item Master file has three record types: A-record and A-record extension, B-record, and C-record. One A-record per item is required. The Item Master A-record contains general item information, and fields used by COM, MRP, and MPSP that are optional for PDM.

You must use a unique item number for every item you want in the Item Master file, including finished goods, raw materials, stocked subassemblies, and special items. For each item, you must include an item description, stocking unit of measure, and item type. If you want to use product costing, see "Product costing" to determine what

additional data you need to include in your Item Master file. The Item Master file has a B-record for each item if:

- MPSP is installed and interfacing.
- MRP is installed and interfacing.
- You select product costing when you answer the PDM questionnaire.

The Item Master B-record contains the costing fields used by PDM. These fields are optional. You may choose to have a C-record for an item, but only if Purchasing is installed and interfacing. The C-record contains fields associated with purchasing an item.

The Item Master file maintenance entry forms (PM-01, PM-02, PM-03, and PM-04) show all the maintainable fields in the Item Master records. This includes all the fields on the offline maintenance forms, but in a different sequence.

The offline maintenance forms (PM-26A, PM-26B, PM-27, and PM-28) show Item Master fields you can update on an offline device.

Product Structure file

The Product Structure file is a required file for PDM. It contains the bills of material (structured parts lists). You and others in your company (such as the engineers and the people in the manufacturing department) must ensure that the bills of material you have on file are complete and up-to-date, or that you have a procedure in place to correct them as they are loaded, before you start to build the Product Structure file. If you are also using features and options or phantoms, see “Features and options” and “Phantoms” to determine how to set them up.

Bills of material indicate the structuring and organization of the data describing what the product is made from (raw materials used in each component, components used in each assembly, and the assemblies used in each end product). You may not want some bill of material changes to go into effect immediately or as they are entered into the Product Structure file. You can control when a change is to become effective by using Effective From or To dates in the product structure records affected. Effective dates are used on Retrieval reports and Costed reports. See Chapter 3, “Inquiry” and Chapter 6, “File Maintenance” for more information.

The Product Structure file maintenance entry forms show what data is stored in the Product Structure file. The offline maintenance form (PM-15) shows the same fields as the Product Structure File Maintenance form (PM-14), but not in the same sequence. Several fields are used only if you want features and options. These fields—feature/options code, feature/option number, feature/option planning factor, and feature/option cost roll-up factor—are explained in Chapter 9, “Forms”.

For each product structure record, you must include the parent item number, the component item number, and the quantity per. (Although quantity per is a required field, the value may be positive, negative, or zero.) The quantity per is the amount of a given component required to make a standard batch quantity of the parent item. You can also include user sequence. (See “User sequence”.) An Item Master A-record and A-record extension must exist for each item used in a product structure. If you want to use features and options and product costing, see “Features and options” and “Product costing” to determine what additional data you need to include in your Product Structure file.

Occasionally, data in the Product Structure file and the Item Master file do not agree. This can occur after an abnormal termination of the product structure maintenance programs or following extensive changes to the Product Structure file that are a result of product engineering changes.

When this happens, the Product Structure file must be reorganized. The reorganization also reclaims deleted record space, making the space available for use. This is performed by selecting option 4 on the CAS Main Menu and then option 4 on the Back Up/Recover/Reorganize menu (AMZM40). Reorganization verifies the existing product structures and resets the values contained in the number of single-level assembly components, (NOSLC), number of parent assemblies where used (NOPWU), and low level code (LOLEV) fields in the Item Master file.

Provides access to follow a structure one level down or all the way to the end and to find all parents in which a component is used.

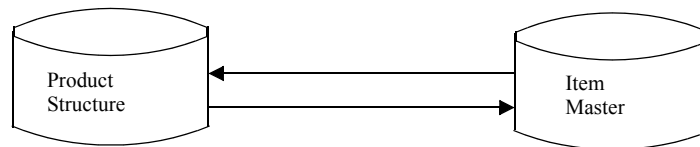

- Component and parent
- Quantity of component per SBQ of parent
- Effective dates

- Item description
- Item number
- Item type
- Unit of measure
- Descriptive data

Figure 2-1. File relationships: Item Master and Product Structure files

Production Facility file

The Production Facility File is an optional file for PDM with two exceptions: if Production Control and Costing (PC&C) or REP is installed and interfacing or if you want to use the Routing file, then the Production Facility file is required.

If you choose to use this file, you must include an ID and description for each facility.

The Production Facility Maintenance form (PM-23) shows all the fields you can enter into a facility record. The offline maintenance forms (PM-30A and PM-30B) show the same fields as the Production Facility File Maintenance form (PM-23), but not in the same sequence. If you want to use product costing, see “Product costing” to determine whether you need to include standard and current rates in your Production Facility files and if standard efficiencies should be used in the costing of labor and overhead.

Defining production facilities

A production facility, as defined by XA, is either a work station, work center, or production line. How you use these terms depends on the needs of your company, but there are some restrictions. For example, routings can contain work stations or work

centers, but not production lines. This is also true for the manufacturing order operations used by the Production Control and Costing (PC&C) application.

Production lines can be made up of a combination of work stations and work centers and are used by the REP application.

Work stations are usually designated work areas along a production line located relatively close to each other. They may be linked together by material handling devices such as transport belts or robotic material handlers. Because they usually perform manufacturing operations that are continuous, there is no queue or output analysis done for work stations.

Production line analysis and consequently work station analysis are omitted from Capacity Requirements Planning since overlapped operation support is not available. Instead, production line loading is shown on REP's Enter and Maintain Schedules display (AMQ442). Generally line loading for production lines tends to be more stable than for work centers. Hence a lesser need for CRP's detailed long range planning is required. Many users in a repetitive environment may use something similar to MPSP's rough cut resource planning to examine long range loading requirements.

Work centers can perform stand-alone operations and do not have to be part of a production line. Often, several activities can be performed at a work center. The queues and output for a work center are measurable and can be analyzed. Generally, work centers are used in conjunction with manufacturing orders in Production Control and Costing.

The type of facility (work center, work station, or production line) usually appears next to the facility ID on displays and reports. This designation helps show facility ID in terms of the user terminology.

For more information about production lines, work stations, and work centers, see the *Repetitive Production Management User's Guide*.

Routing file

The Routing file is an optional file for PDM. If you choose to use this file when answering the PDM questionnaire, you can print, on demand, a report showing the sequence of operations for a specified item and the facility where each operation takes place.

The Item Master and Production Facility files must be installed before you can use the Routing file. For each routing record, you must include the parent item number, the facility ID, and the operation sequence number. If you want to use the yield percentage to reflect the loss of some portion of the end items at each operation, you must change the operation yield to a percentage other than 100%. An Item Master A-record and A-record extension must exist for every parent item in a routing, and a Production Facility record must exist for every facility ID used. The Routing File Maintenance form (PM-17) shows the same fields as on the offline maintenance form (PM-29), but not in the same sequence. If you want to use product costing, see "Product costing" to determine what data you need to include in your Routing file.

To report costs that occurred outside of your own plant, you can use the outside cost field in the Routing file. In this case, the production facility ID could represent the outside location.

If you want to use milestone reporting in Production Control and Costing (PC&C), you can group operations together in PDM to simplify reporting. The milestone function allows you to define several operations within a routing as a milestone group, beginning with a milestone start and ending with a milestone stop. In a Job shop type (J) milestone group environment, all pieces of a lot move together from operation to operation. Shop activity reported at the milestone sets all the preceding operations in the group to “in process” status. A flowshop-type (F) milestone group represents a repetitive (assembly line) or batch process oriented environment. Shop activity reported at the milestone reflects the shop activity required to complete the same number of units at each operation within the milestone group. See the *Production Control and Costing User’s Guide* for a complete description of milestone group reporting.

Purchase routing defines the dock to stock process for purchased items.

Scheduling specific work centers

The following discussion applies only if *PDMPlus* and FCPS are installed and interfacing.

Your routing data (MOROUT or ROUTNG) specifies a work center (WC) for each operation. FCPS uses operation and WC definitions to generate finite capacity schedules for the work center. In most cases, the WC definition in PDM enables FCPS to generate realistic production schedules. However, there are times when the general definition for a particular work center is not adequate. Sometimes, a WC definition (in WRKCTR) and the corresponding resource group definitions (in FCPS) do not properly represent certain realities on the shop floor. The three common cases of this are:

- An item prefers the WC machines in a different order than is represented by the general WC definition.
- An item is limited to using only a subset of the machines in a work center.
- There is a combination of the first two cases.

The first part to solving this problem involves *PDMPlus*. Here, you can specify a replacement work center in the **FCP1** field. The standard work center will still be used in ROUTNG (and MOROUT), thus avoiding creating “extra capacity” and adversely affecting CRP. Using *PDMPlus*, you would enter *MS21 (for example) in the **FCP1** field, as a replacement for the general WC ID MS020 that is in ROUTNG.WKCTR. The asterisk tells the Update Orders program in FCPS that this work center replaces the one specified in ROUTNG. If an asterisk is not entered, the entry in the **FCP1** field is the standard additional resource required on the job step.

In the second part to solving this problem you would use the Resource Group editor in FCPS to define the replacement WC MS21. When defining the Resource Group, you would specify the WC machines in the order preferred by this item and/or specify only the machines that are valid for this item. This enables FCPS to use the MS21 definition for this item when it generates production schedules.

Note: Several items can share the same Resource Group definition.

Routing Description file

The Routing Description file is an optional file for PDM and is secondary to the Routing file. If you choose to use this file when answering the PDM questionnaire,

additional operation descriptions can be added for each routing operation during file maintenance.

Item Foreign Language file

The Item Foreign Language file contains foreign language descriptions keyed to specific item number/language code combinations.

To use this file, you must set up foreign language descriptions for each item that you want to identify in the foreign language. You must also specify a language code for each different foreign language you use for the foreign language descriptions. Each resulting foreign language description record matches one item number/language code combination and contains descriptions in lengths of 10 characters, 20 characters, and 30 characters. This variety in description lengths allows you to use short names or abbreviations as well as more detailed names to identify your items in foreign languages.

The item number from the Item Master file gives you access to the Item Foreign Language file records for maintenance and inquiry.

File summary

The Item Master and Product Structure file are required.

The Production Facility, Routing, Routing Description, and Item Foreign Language files are optional. However, if PC&C or REP is installed and interfacing, the Production Facility file is required. If you want to install the Routing file, the Item Master and Production Facility files are required. If you want to install the Routing Description file, the Routing file is required.

PDM uses the Item Master, Production Facility, Routing, and Routing Description files to retrieve the sequence of operations for an item and information about the facilities those operations pass through.

You can load and maintain the Item Master, Product Structure, Production Facility, Routing, and Routing Description files from an offline device in addition to using online file maintenance. You cannot load the Item Foreign Language file from an offline device; you can alter this file only through file maintenance.

You can also select to load the Item Master, Product Structure, Routing, and Routing Description files in stages using an offline device. That is, you load the files one section at a time instead of loading the complete file all at once. This method can be an advantage to you in loading the Product Structure, Routing, and Routing Description files, because they are large and are usually built in stages. If you do choose to load your files in stages, make sure your files are coordinated: the Product Structure file must be made up of items in the Item Master file, and Routing files must point to facilities in the Production Facility file and to items in the Item Master file. You can begin using the PDM application with only the Item Master and Product Structure files. Later, you can add the Production Facility, Routing, and Routing Description files.

File maintenance for Product Data Management

You can add, delete, or change records online or offline for the Item Master, Product Structure, Routing, and Production Facility files. These records carry the basic data for items and facilities, such as item type, engineering drawing number, and stocking unit of measure (for items); and foreman, planned queue, and overhead rate (for facilities).

The bill of material for an assembly is stored in the Product Structure file as a series of parent (assembly) to component (subassemblies, parts, or materials) that are used directly in the manufacture of an item. There are bill of material retrievals you can use to retrieve all the levels of a product down to raw materials and purchased parts. This way, you can maintain a single copy of the bill of material for each assembly and subassembly, regardless of the number of products each is used in.

The manufacturing routing for an item is a sequence of operations that provide a connection between the item and the appropriate facility for each operation in the routing. Routings and their operations are stored in the Routing file. This means that the information for each facility is maintained in a single record, but each facility could be referenced by all manufacturing operation records.

The purchasing routing identifies the receiving process to follow between the time the item is received at the dock until it is received into stock. You can set up a receiving process that meets your company's needs using an unlimited number of steps to control and schedule item receipts. You can also use a generic purchasing routing (for example, one routing for all raw materials) to simplify your receiving and data entry processes.

The routing record contains a short description for routing operations. Additional routing operation descriptions are included in the Routing Description file.

The reverse view of the bills of material and routing relationships, "component where-used" and "facility where-used," are automatically maintained when you change any relationships in the Product Structure or Routing files. Retrievals are supplied that can generate where-used reports for the components or facilities you specify.

Product Structure and Routing file maintenance do not affect open order master files. Orders released after Product Structure or Routing file maintenance is completed use the updated information from those files. You can run file maintenance for orders and schedules using either Inventory Management or Production Control and Costing. For information about maintaining open order master files, see the user's guide for the application you use to do that task.

Item base prices can be maintained online. You can change the base price, effective date, pricing unit of measure or item price class.

Item foreign language descriptions can also be maintained online. Each description record is accessed in the Item Foreign Language file by a unique item number and language code combination.

You can maintain code files online. Some examples of code files are: Unit of Measure Master, Country, and Item Type Class.

You can also change product costing function options in the PDM Control File online. Those remain in effect until you change them again in file maintenance. In this file,

you define which fields are used to compute the standard and current unit cost amounts. You also specify in which of four cost summary categories you want to assign the various cost elements and what the summary cost titles will be. If EPDM is activated, you must define a default site identifier prior to migrating PDM data to EPDM.

Special maintenance transactions

For some types of maintenance, using individual add, change, and delete transactions can be very time consuming. You can save time by using the PDM special maintenance transactions: same-as-except (SAE), delete structure, delete routing, mass replace, mass delete, and set defaults.

SAE: same-as-except. When you want to create an entire single level bill of material or routing that is similar to an existing one, you can use the same-as-except (SAE) transaction. The Product Structure same-as-except transaction copies the entire structure of an existing bill of material and uses it as the basis for a new bill of material. The Routing same-as-except transaction works the same way. An existing routing is copied and used as the basis for a new routing.

You can then add, change, or delete any components or operations that are different for the new parent item. If you do not use any SAE maintenance (add, change, or delete transactions), you have identical product structures or routings for both parent items.

If you make extensive use of the same-as-except transaction to handle products with features and options, consider using the feature/option capability described in “Features and options”.

Delete structure, delete routing, mass replace, mass delete. The delete structure transaction deletes an entire single level structure. Using this feature, you can delete all direct components of a parent with one transaction. The delete routing transaction deletes all operations in a routing. Using this, you can delete all operations in a parent’s routing with one transaction.

The mass replace transaction replaces one component with another in every bill of material where the original component was used. You can specify an effective date for the mass replace. Using this, you can replace a specific component with another in every product structure where it is used with one transaction. The mass delete transaction deletes a component from every bill of material in which it is used. Using this, you can delete a specific component from every product structure where it is used with one transaction.

These multiple action transactions can save considerable time; however, they should be used with care as one error could take a long time to correct.

Set defaults—Item Master Maintenance. You can set defaults for an Item Master file maintenance session using the set defaults transaction. If you are adding an item that is similar to an existing item, you can copy the existing item’s information to use as defaults. You can then add, change, or delete any information that is different for the new item. If you are adding a group of items that are similar, you can type in the defaults one time and they are set for the file maintenance session. The defaults you set override any existing defaults and are in effect only for the current file maintenance session.

Features and options

If you select this function when answering the PDM questionnaire, you can indicate that an end item has certain characteristics called features. You can indicate required features, nonrequired features, or no features at all. Within a feature you can make option selections. For example, red or blue are options within a color feature. When you answer the PDM questionnaire, you set up a “template” that accommodates the features and options of all end items. The template determines the format of the S-number which is used to specify a requested set of options for features of an end item. See “Use of the S-number” for more information.

Warning: Once a template is created and used, it is very difficult to change.

To use features and options, you must follow certain rules. A feature item is designated by Item Type Code F. A feature can only describe an end item (an item that is not a component of anything else). The structure record that defines a feature to an end product must contain a feature/option code of R or N to designate whether the feature is required or nonrequired, and a feature number to designate what position within the S-number this feature occupies among other features for this product. The options of a feature are designated in the Product Structure file by a feature/option code of O and a feature/option number which is unique for this feature. An option may be designated by any combination of characters A-Z or 0-9. A one position option must have a leading 0 in the Product Structure file, and no option may be 00, because that is reserved for omitting nonrequired options. The feature or option number cannot contain duplicates in a single-level structure. Otherwise, unpredictable results may occur. For example, in Figure 2-2, wheel size is feature 1 and an 8-inch diameter wheel is option 1. There can be no other feature on the end-item designated as 1 and no other option on that feature designated as 1.

Product configuration of end items

If you have products with selectable options, the feature/option function of the PDM application can be very useful. Because of these options, the end item (final products) can have thousands of possible configurations. It would be prohibitively expensive to maintain a separate bill of material for each configuration of such an end item. Consider a simple example of a spray unit with or without an automatic shutoff switch, with three tank sizes and three wheel sizes. This final product or end item has 18 (2X3X3) different configurations.

Figure 2-2 shows how the bill of material would be structured to describe the standard product options for the spray unit. All the selectable options for the product are grouped (structured) under features. The boxes represent the Item Master records for the product, features, options, and common components. The connecting lines represent the bill of material (product structure) records. Codes in the product structure identify each feature of a product as required (R) or not required (N). After the bill of material has been loaded as shown, specific types of spray units can be selected for costing, customer order entry (if the Customer Order Management application (COM) is installed and interfacing), and manufacturing order release (if the Inventory Management application (IM) is installed and interfacing).

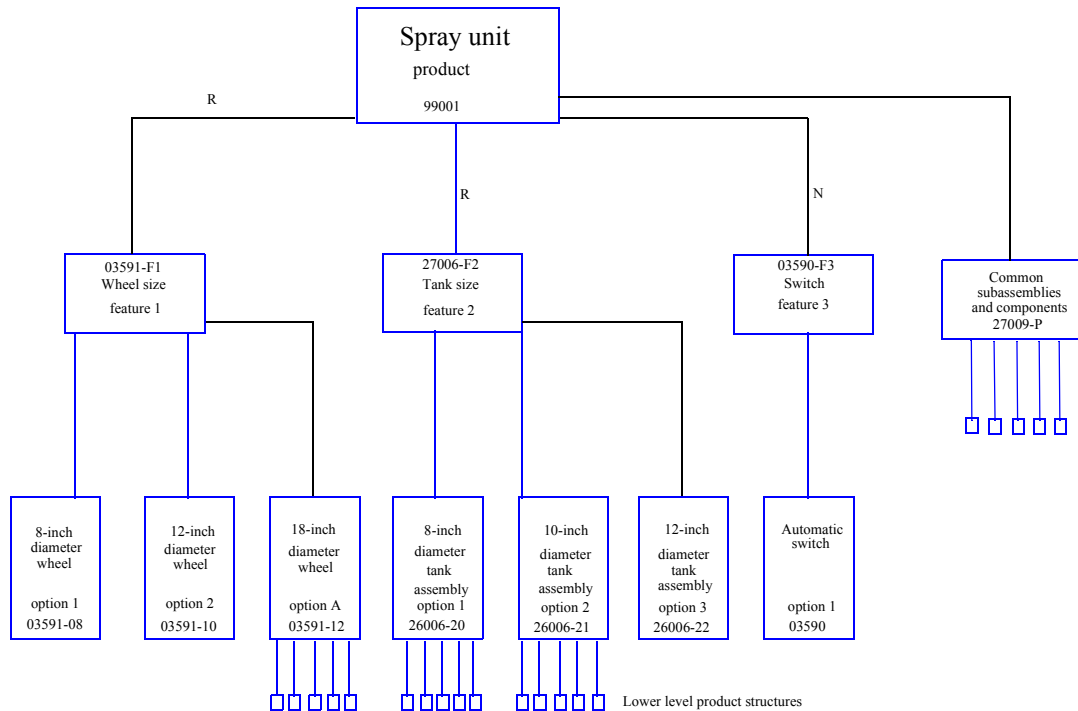

Figure 2-2. A spray unit with features and options

Notes:

1. Do not create duplicate feature or option numbers on the same product structure unless the effective dates are specified and do not overlap. The system does not edit for multiple parts with the same feature or option number.
2. Also, if the Material Requirements Planning application (MRP) is installed and interfacing, requirements for the options can be prorated across the options for a feature by the expected use percentage, then generated based on a sales forecast for the end item.

Use of the S-number

In PDM, COM, and IM, an S-number (Select Number) is used to retrieve a specific product configuration of an end item. You determine the S-number by creating a feature/option field size template in the PDM questionnaire. Once you set up this template, you must coordinate your S-numbers following the format of the template. This template is 20 positions and is used for S-numbers across all end items.

When you answer the questionnaire, you indicate the field size (number of characters) for each of up to 20 features. A feature can have a field size of one or two characters depending on how many options that feature has. If a feature has 35 or fewer options, it only needs a field size of one (one template position). If a feature has more than 35 options, it needs a field size of two (two template positions). Therefore, a product may have the following:

- Up to 20 features, if each feature has from 1 to 35 options and a field size of one character

- Up to 10 features, if each feature has from 1 to 1295 options and a field size of two characters
- Up to 19 features, some features with up to 35 options and a field size of one character and other features with up to 1295 options and a field size of two characters.

For example, if you decided that seven features, three for up to 35 options and four for up to 1295 options, accommodate all the variations in your bills of material, you might set up the feature/options field size template as:

2 2 2 1 1 1 2

Features 1, 2, 3, and 7 have a length of 2 to accommodate up to 1295 options each and features 4, 5, and 6 have a length of 1 accommodating up to 35 options each.

Using the template above, you could set up an S-number for end item A as 22AB321230Z which translates as 22/AB/32/1/2/3/0Z: option 22 for feature 1, option AB for feature 2, option 32 for feature 3, option 1 for feature 4, option 2 for feature 5, option 3 for feature 6, and option 0Z for feature 7. The length of the S-number is variable, but cannot exceed 20 digits. In the example above, the sum of the field sizes in the template is 11. The remaining 9 may be saved for future requirements and may be designated in any combination as discussed. In Figure 2-2, if you use all (20) one-digit features, S-number 321 specifies a spray unit with 18-inch wheels, a 10-inch diameter tank, and an automatic shutoff switch. S-number 130 specifies a spray unit with 8-inch wheels, a 12-inch diameter tank, and no automatic shutoff switch. If you were using all (10) two-digit features, the spray unit with S-number 020301 would have 12-inch wheels, a 12-inch diameter tank, and an automatic shutoff switch.

If you want to eliminate a feature but you do not want to change the feature number in all related product structure records, you can rerun the PDM questionnaire and change that feature's field size to zero. A zero field size takes no position in the S-number. The new S-number is then condensed and that feature is eliminated. If you want to eliminate the feature without condensing the S-number, use PDM Product Structure file maintenance to change the feature/option code to N for nonrequired for all the product structure records in which this feature is used. Then you can use a zero option number for this feature which causes that feature to be bypassed.

Note: Your answers concerning the field size of each feature in the PDM questionnaire must correspond to the number of options for that feature in the associated feature/option Product Structure records. For information on how to fill out the feature/option number field on the Product Structure data entry forms, see Chapter 9, "Forms".

Phantoms

If you have a group of components that are frequently used together in assemblies, you can save time and space in the product structure file by making that group of components a phantom item in the product structure record. A phantom item (item type=0) is an item that is not physically stored in inventory and is normally defined for the convenience of material planning or engineering. A phantom can be used to store, in one structure, a group of parts common to many assemblies. For example, refer again to Figure 2-2. It may be convenient to establish a phantom item to represent the common subassemblies and components of the spray unit.

Phantoms can be parents or components of other phantoms. An option can be a phantom. A phantom cannot be a feature.

User sequence

The user sequence function allows the retrieval of an item's components for reports and/or inquiries to be in a sequence other than component item number.

The user sequence field allows a component item to appear more than once in a bill of material.

The user sequence field is an optional alphanumeric field. If you do not select this option at application tailoring, the "component retrieval sequence" remains in component item number sequence. Either one of the following sequences can be selected for the Product Structure file when answering the PDM questionnaire:

1. User sequence/component item number
2. Component item number/user sequence.

Note: If you rerun the PDM questionnaire and change the sequence, you must reorganize the Product Structure file for the change to take effect.

Product costing

If you select this function when answering the PDM questionnaire, you are allowed to establish, maintain, and simulate two standard types of product costs: current and standard.

You set both current and standard costs anytime you want, but it is customary to set standard costs once a year. Consult your accounting department for the procedures you should use. However, you may want to update current costs frequently during the year to closely approximate actual costs but only update standard costs at the end of the fiscal year. To do this, you can select option 12 on the Costing menu (AMEM04) to roll current costs to standard costs.

With the product costing function you can simulate standard costs, current costs, or both, and know how the changes would affect your unit costs before you make actual changes and recost all items. For example, you can ask the question, "How are my unit costs affected if I use average yield to calculate my costs, or if I temporarily change values in the Item Master record, Production Facility record, Purchase Overhead Table, or in the Labor/Overhead Table?"

When you use PDM product costing to cost some or all of your products or to simulate cost changes, you can choose to use current only, standard only, or both. Current and standard costs are broken down into several costing elements for both this-level and lower-levels. This-level costs are costs that occur at this level in the product structure. Lower-levels costs are costs that occur prior to this level—at lower levels in the product structure. In addition to the usual costs, you also can define four other optional costs. The breakdown of costs is shown in "Unit cost".

Product costing requires the B-record for every item in the Item Master file and product structures for manufactured items. The B-record is used to store the cost elements that make up current and standard costs. Full costing runs use routings, production facility, product structures, purchase material costs, the Labor/Overhead Table, or the Purchase Overhead Table to calculate costs. The product structure defines where an assembly's component costs come from (the bill of material).

See Appendix C, "Information retrieval and calculations" for detail information on costing calculations.

Actual costing systems are offered by the PC&C and IM applications. See the *Inventory Management User's Guide* and the *Production Control and Costing User's Guide* for more information about actual costing.

Unit cost. Current and standard costs are divided into two levels: this-level content and lower-level content. The sum of this-level and lower-level content are further subdivided as shown below. The following is a breakdown of the cost elements within the Item Master B-record. They are the same for both levels. The PDM Control file setup determines which cost elements are used to compute the unit cost for an item. Note there are four optional costs that are user-defined.

Standard and Current Costs.

- This-level material cost
- This-level outside operation cost
- This-level purchase overhead cost
- This-level setup labor cost
- This-level run labor cost
- This-level manufacturing overhead cost
- This-level setup machine cost
- This-level run machine cost
- This-level other 1 cost (optionally)
- This-level other 2 cost (optionally)
- This-level other 3 cost (optionally)
- This-level other 4 cost (optionally)

- Lower-level material cost
- Lower-level outside operation cost
- Lower-level purchase overhead cost
- Lower-level setup labor cost
- Lower-level run labor cost
- Lower-level manufacturing overhead cost
- Lower-level setup machine cost
- Lower-level run machine cost
- Lower-level other 1 cost (optionally)
- Lower-level other 2 cost (optionally)
- Lower-level other 3 cost (optionally)
- Lower-level other 4 cost (optionally)

The sum of the above is equal to an item's standard or current unit cost, based on the PDM Control file definition.

The Inventory Management (IM) application maintains three unit cost fields (average, last, and standard) for inventory valuation and reporting purposes. A fourth unit cost field is the **Unit Cost Default** in the Item Master file. The IM application, if installed and interfacing, allows you to roll the PDM standard cost into the unit cost default at the end of a period when the stock status report is run.

Cost elements. During file maintenance, item types are checked to determine which items have cost elements that can be entered directly into the B-record and which items have cost elements that must be calculated.

During a full costing run, cost elements are calculated for each item depending on the presence or absence of components, the Cost Technique Code (see "Cost technique code"), and the presence or absence of a routing. A check by the application tells you, based on the item type, which cost elements are expected but not found, and which cost elements are present but not expected. Some this-level costs and all lower-level

cost elements are calculated from product structures, routings, the Purchase Overhead Table, or the Labor/Overhead Table. The item type code controls whether a product structure can be added to an item and what cost elements can be calculated.

The following information can be useful in validating that the correct cost elements are present for every item that you cost. Table -2-2 shows valid cost elements.

Item type codes. The following is a list of item type codes. Then follows a discussion of the item types.

0	Phantom
1	Assembly and subassembly
2	Fabricated
3	Raw material
4	Purchased
9	User option
F	Feature
K	Kit

Manufactured items. A manufactured item (item type 1 or 2) should have labor, machine, and manufacturing overhead costs. Sometimes a manufactured item will have outside operation costs.

Manufactured items can have a product structure. The structure will be used to calculate lower-level costs for them. A routing also can be added to a manufactured item. If the item's Cost Technique Code is R, the routing times and facility rates are used to calculate labor, machine, and manufacturing overhead for the item.

Purchased items. A purchased item (item type 3 or 4) should have this-level material, purchase overhead, and, normally, no labor costs. However, labor and manufacturing overhead costs can be added to purchased items to reflect costs for inspection, dock-to-stock movements, etc. Purchase overhead is usually reserved for indirect expenses of an unusual nature that are related to an item, such as special handling or insurance.

Purchased items cannot have a product structure; therefore, they will never have lower-level costs calculated for them. A receiving router can be added to a purchased item, but a purchased item cannot have a Cost Technique Code of R. Therefore, routing times and facility rates cannot be used to calculate labor and manufacturing overhead for purchased items.

Purchase overhead is calculated for purchased items using the item's material cost and the purchase overhead percent from the Purchase Overhead Table that corresponds to the purchase overhead code in the item's B-record.

Special items. Because it is not always easy to fit an item into a make or buy category, a special item type is defined for that purpose. The special item type is defined as code 9 (user option). With item type 9, PDM does not roll up lower-level costs. This item's unit cost is the sum of the this-level content fields. If the item has a cost technique code = R and has outside operation costs, these costs also are included in the calculation of the item's unit cost.

Feature items . Feature items (item type F) are treated differently. Because they have no costs themselves, no cost is accumulated for a feature without components. If the feature does have components, its costs are an accumulation of a percentage of the cost of each of its options (components). The percentage is determined by the feature/option cost roll-up factor assigned in the product structure.

Kit items . Kit items (item type K) cannot have a product structure or exist in a product structure. PDM costing does not cost kit items. See the *COM User's Guide* for more information on kits.

Valid cost elements for purchased, manufactured, and special items.

Table 2-2. Valid cost elements for purchased, manufactured, and special items

	M=Manually entered	C=Calculated	Purchased	Manufactured	Special
This-level					
Material cost		M		C	M
Outside Operations cost		M		M/C	M/C
Purchase Overhead cost		C		C	C
Setup Labor cost		M/C		M/C	M/C
Run Labor cost		M/C		M/C	M/C
Manufacturing Overhead cost		M/C		M/C	M/C
Setup Machine cost		M/C		M/C	M/C
Run Machine cost		M/C		M/C	M/C
Other 1 cost		M		M	M
Other 2 cost		M		M	M
Other 3 cost		M		M	M
Other 4 cost		M		M	M
Lower-level					
Material cost		N/A		C	N/A
Outside Operations cost		N/A		C	N/A
Purchase Overhead cost		N/A		C	N/A
Setup Labor cost		N/A		C	N/A
Run Labor cost		N/A		C	N/A
Manufacturing Overhead cost		N/A		C	N/A
Setup Machine cost		N/A		C	N/A
Run Machine cost		N/A		C	N/A
Other 1 cost		N/A		C	N/A
Other 2 cost		N/A		C	N/A
Other 3 cost		N/A		C	N/A
Other 4 cost		N/A		C	N/A

Legend:

Key entered value at a work station

cal calculated

N/A not applicable

Cost technique code

The Cost Technique Code determines which of three methods is to be used to calculate an item's this-level setup labor, run labor, setup machine, run machine, and manufacturing overhead. The Cost Technique Codes and their associated methods are:

- blank** Setup labor, run labor, setup machine, run machine, and manufacturing overhead are not calculated. PDM uses the cost you enter in the Item Master B-record.
- T** Costing Labor/Overhead Table rates and percentages are used with the Run Labor Hours from the Item Master B-record to calculate run labor and manufacturing overhead, regardless of item type.
- R** Routing times and facility rates are used to calculate setup labor, run labor, setup machine, run machine, and manufacturing overhead. This method requires the Routing and Production Facility files.

Cost technique blank. The values typed in the Item Master B-record for this-level setup labor, run labor, setup machine, run machine, and manufacturing overhead are used as cost elements for the item.

Cost technique T. Costing rates and percentages from the Labor/Overhead Table are used with labor hours from the Item Master B-record to calculate run labor and manufacturing overhead. The formulas are:

- This-level setup labor cost = zero
- This-level run labor cost = Labor hours (from Item Master file) x Labor rate (from Labor/Overhead Table)
- This-level setup machine cost = zero
- This-level run machine cost = zero
- This-level manufacturing overhead cost = (Labor hours from Item Master file) x (Overhead rate from Labor/Overhead Table) or (This-level run labor as calculated for cost technique code T) x (Overhead percent from Labor/Overhead Table).

Note: A negative value in the Labor/Overhead Table indicates that the value is a percentage. A positive value indicates that the value is a rate.

Cost technique R. Routing hours and production facility rates are used to calculate this-level setup labor, run labor, setup machine, run machine, and manufacturing overhead associated with each operation required to complete the item. These values are summed up and stored in the Item Master B-record for the item. The calculated values replace any values you may have typed into these cost elements during file maintenance. Operation yield affects cost elements calculated during cost technique code R. The standard efficiency of the work center is also included if Yes is answered to tailoring question E03.

Notes:

1. Cost Technique Code of R is not allowed for item types 3, 4, F, or K.
2. To use a cost technique of R, the Routing and Production Facility files must be installed and the item must have an active routing (status 10).
3. Only the routing for the primary process is used to calculate labor and overhead related costs when using cost technique R.

Manufacturing overhead calculations

The manufacturing overhead calculations depend on the manufacturing overhead code specified in the facility where each operation is performed. Manufacturing (Mfg) overhead is typically used to capture the cost of capital equipment and other expenditures. This-level manufacturing overhead costs are calculated according to the Production Facility Manufacturing Overhead Code, as shown in the following table:

Overhead code	Mfg overhead
blank	zero
A	machine cost x overhead percent
B	labor cost x overhead percent
C	machine time x overhead rate
D	labor time x overhead rate

Time Basis Code

A Time Basis Code (TBC), defined in the Routing file, allows the routing time to be considered the time to make a specified number of the item. To calculate the run labor and run machine costs for an item, the routing time is factored by its TBC.

The Time Basis Codes and their associated values are:

blank	Hours per unit
1	Hours per 10 units
2	Hours per 100 units
3	Hours per 1,000 units
4	Hours per 10,000 units
P	Pieces per hour
H	Hours per lot
M	Minutes per piece
C	Cost per piece (can be used for outside operations)

Note: If the Time Basis Code is H and you are doing a costing run, PDM does not adjust the machine and labor run hours in the Routing file with cumulative yield figures. If the Time Basis Code is H, a lot can be for any quantity. PDM costing calculates cost based on a standard lot size. The time not adjusted assumes order quantity is equal to standard lot size. If the Time Basis Code is P, labor represents the quantity per hour.

Outside operations . For Routing records with a Time Basis Code of C, the prime load code in the Production Facility record should be set to zero so that there are no setup or run labor hours associated with an outside operation for scheduling.

For items that use Cost Technique Code R, Time Basis Code C in one of its routing records indicates an outside operation. Cost is calculated for this operation and placed in outside operation cost in the Item Master file. No efficiency is considered.

Time Basis Code C uses outside operation cost fields in the routing operation record as the cost of the operation. It does not use a rate from the Production Facility file. It can, however, use the Production Facility file for outside operation overhead content.

Cost roll-up

Unit costs for all items are recalculated during costing or simulation by a two stage process. In the first stage, this-level costs are calculated for all items using a cost technique code of T or R.

The second stage of the costing process is a cost roll-up that uses only the cost elements typed in or calculated in the Item Master B-record from the first stage of costing. Figure shows an example of the cost building process.

Cost roll-up begins with the items that have the lowest low level code in any product structure. This lower-level setup labor, run labor, setup machine, run machine, and manufacturing overhead costs for each item are calculated if they exist.

The material and purchase overhead content for the item is calculated by accumulating the material and purchase overhead content for purchased components into this-level material and purchase overhead content for the item. The entire material content and purchase overhead content for manufactured components is accumulated into this-level purchase content for the manufacturing item.

The unit cost for the item is then calculated by summing the this-level and lower-level cost elements described in "Unit cost". The exception is item type 9, which calculates unit cost by summing only this-level costs. This item's unit cost is the sum of this-level content fields. For item type=9, if the item has a cost technique code=R and has outside operation costs, these costs are included, in addition to this-level content, in the calculation of the item's unit cost.

When the item's unit cost has been calculated, the elements that make up the cost are compared to the item type. A message is printed for the item showing any cost elements that are missing or not needed for that item type.

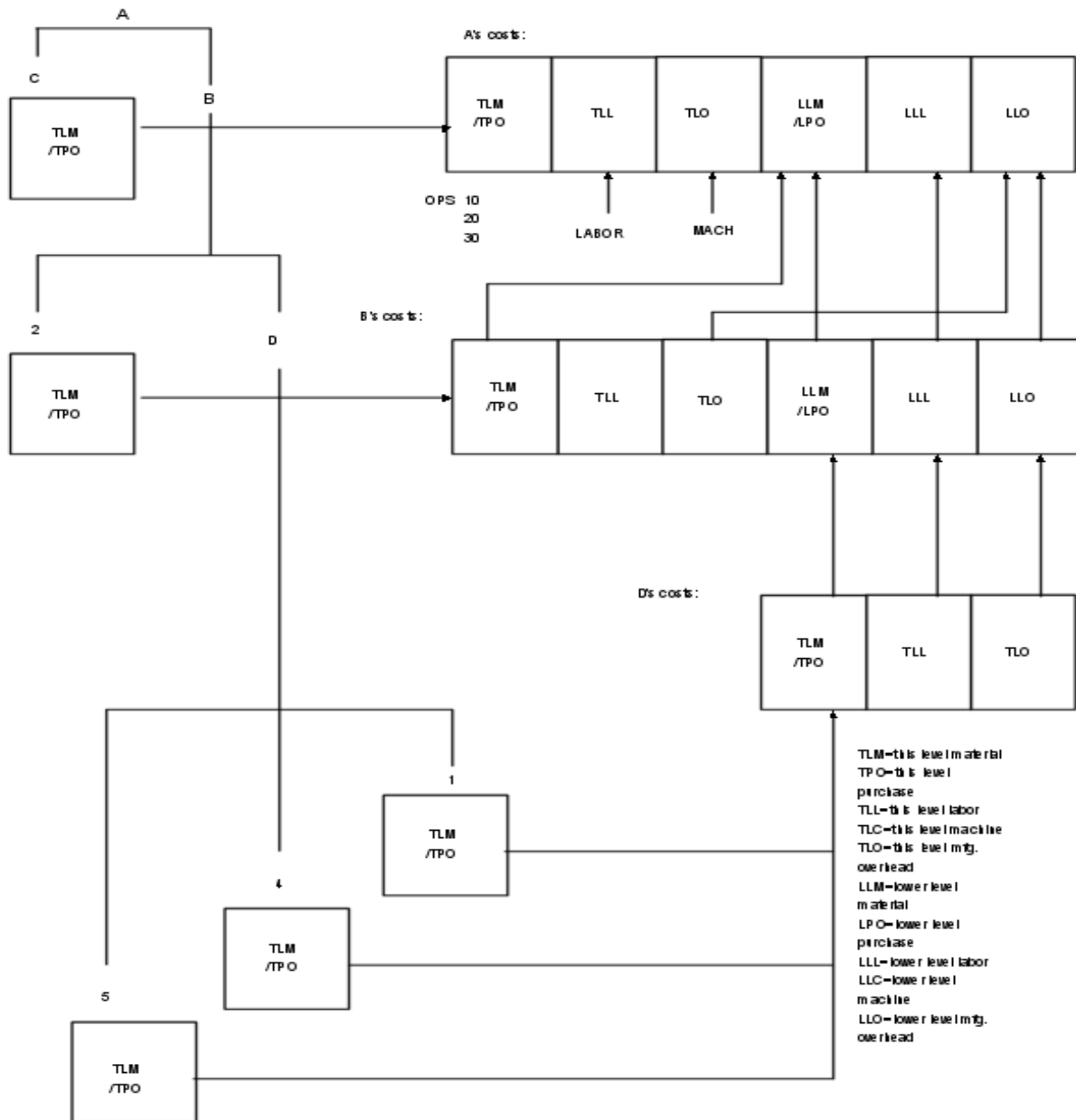

Note: Item Type Code 9 (User option) can have this-level material, purchase overhead (calculated), setup and run labor, setup and run machine, manufacturing overhead, and components. If you select Item Type Code 9, setup labor, run labor, and manufacturing overhead (this level) are calculated from the routing (cost technique code = R) or from the Labor/Overhead Table (cost technique = T). Or, if cost technique code is blank, you can manually enter setup and run labor, setup and run machine, and manufacturing overhead costs. With item type 9, PDM does not roll up lower-level costs. Purchase overhead is calculated based on the Purchase Overhead Table code and user-entered material content. This item's unit cost is the

sum of this-level content fields, as defined in the PDM Control file. If the item has a cost technique code = R and has outside operation costs, these costs are included, in addition to this-level content, in the calculation of the item's unit cost.

An item that is a feature uses the percentage for each option in the cost roll-up factor field in the Product Structure record for that option to determine the contribution of that option to the feature's cost. Thus, the cost of a feature can be handled several ways:

- Use all zero cost roll-up factors. The feature and the end product do not contain any costs for options, only the base product.
- Choose one option per feature; assign it a cost roll-up factor of 1, and assign the other options a factor of zero. The feature and the end item contain costs of a "most standard" or a "minimum" product, depending on how you select the option.
- Split the cost among the options in a feature according to expected usage. For example, among three options for a feature, any combination is allowed that totals 1.0 or less—.50, .25, .25; or .40, .35, .25; or .15, .65, .20; or whatever the mix may be. Be sure that the total of the factors represents the cost you want to include for that feature. The application issues a warning message whenever the total of the cost roll-up factors of the options for a feature exceeds 1.0. However, this condition is allowed to occur because if you use engineering effectivity dates to phase in a replacement option item, the sum of the cost roll-up factors (including both the new and old options) might legitimately exceed 1.0.

The component's cost, printed on PDM reports, is always calculated. It is the sum of material and purchase overhead content this-level and lower-levels plus setup labor, run labor, setup machine, run machine, and manufacturing overhead content lower-levels.

Negative quantities

Negative quantities are allowed for use in more accurate calculations of end item cost. Negative quantity components are carried along with the end item as a detail record in the Manufacturing Material Detail file (MODATA). However, components with negative quantities do not update manufacturing allocation in the Item Balance file during manufacturing order release. Therefore, these components are not considered during MRP planning after Manufacturing Order Release has occurred. Only components with a positive quantity per update manufacturing allocations in IM. The pick list, however, will show the 'netted' quantities for that component.

Full and selective costing

Two product costing methods are available: full costing and selective costing. Full costing is used to cost all products. Selective costing is used to cost new items or items with incomplete costs without changing the current or standard costs of items whose costs have already been established. Selective costing is used to incorporate corrections to items that were improperly costed when full costing was run. After you complete a full costing run, there may be errors in your data base, and the calculated costs for some items may be of no value to you in evaluating the cost of the product or in determining the profit it is earning for your company. After a full costing run, you can correct the cost elements that are flagged as missing or not needed and then run selective costing to complete the current or standard costing run.

A full costing run starts by calculating the costs for the lowest level items. Those costs are rolled up into the higher level (parent) item's costs, until the costs for the end items

have been recalculated. All items are costed and their Recost Flag and Cost Status Codes are updated.

Selective costing works basically the same way. Instead of costing all items, however, only those items that have been selected are costed and have their Cost Status Codes set. The effect of any cost change from Product Structure, Routing, Production Facility, or Item Master B-record file maintenance or changes to the Labor/Overhead Table is reflected in each higher level parent above it that has a nonblank Cost Status Code (Cost Status Codes D, T, or L). Any cost change is reflected as far up a product structure as is permitted by the Cost Status Codes of each item in the structure above the change.

Selective costing notifies you of missing or incorrect cost elements through use of the cost status code and allows you to correct the indicated errors and recalculate the cost of every item that was affected by your correction. An example of an item with incomplete costs is a purchased item with no material cost or a manufactured item with no labor content.

Recost flag and Cost Status Code

The Recost Flag and the Cost Status Code are independent of each other and are used to identify different costing problems associated with an item's costs. The Recost Flag indicates that a change has occurred since the last costing run. The Cost Status Code is not affected by change and shows the status of an item's cost elements the last time they were evaluated. The Recost Flag signals that the basis for the cost of the item has changed for its current costs, its standard costs, or both.

The Recost Flag is set on when Product Structure, Routing, or Item Master B-record file maintenance affects an item's cost elements. For example, maintenance to routing operation yields, recalculation of cumulative yield, or recalculation of adjusted quantity per sets the Recost Flag. When the cost elements of an item are affected, the cost of any parent that uses the item as a component is also affected. The Recost Flags and their meanings are:

- blank** The item does not need costing.
- C** The item needs current costing.
- S** The item needs standard costing.
- B** The item needs current and standard costing.
- N** This is a new item and needs current and standard costing.
- O** This is a new item and needs current costing.
- P** This is a new item and needs standard costing.

An item is considered a "new item" if it was entered in the Item Master file after the last full costing run. It remains a new item until the next full costing run is performed (at which time its Recost Flag is updated) or Selective Costing for New Items for Both Standard and Current costs is run. If Selective Costing for New Items for Both Standard and Current costs is run, the Recost Flag for a new item is updated from "N" to "B".

During a full costing run, all items' current costs, standard costs, or both are costed and the Recost Flag is updated. If both current and standard costs are costed, the Recost Flag is blank to show that all costs are complete. If only current or standard costs are costed, the Recost Flag shows which costs still need to be costed.

The Cost Status Code describes the status of an item's cost elements the last time the item was costed. It is not affected by changes, such as Product Structure, Routing, or Item Master B-record file maintenance. The Cost Status Codes and their meanings are:

- blank** All costs are complete.
- D** The item's product structure, routing, or both is inconsistent with its item type.
- T** Some of the item's this-level costs are inconsistent with its item type.
- L** Some of the item's lower-level costs are inconsistent with its item type.

If an item has more than one condition, the highest priority code is used. In order of priority, D is the highest, followed by T and L. If the Cost Status Code is blank, XA considers the item's costs complete. If the Cost Status Code is D, T, or L, the item's costs are considered incomplete. The Cost Status Code only shows that some of the item's costs may be missing or not needed. It does not show the accuracy of the calculated costs.

Note: Both selective and full costing updates the cost status code.

The Cost Status Code for each item is set during costing. The Cost Status Code of a component then affects the cost status of each parent during the roll up process and ultimately is reflected in the cost status of the item. In Figure 2-3 on page 2-26, the Cost Status Code of purchased item 3 is T because of missing cost elements. Cost Status Code L in item C indicates a lower level cost problem (incomplete costs for item 3). Likewise, Cost Status Code L for items A, C, and X indicates a lower level cost problem, due in this case to purchased item 3.

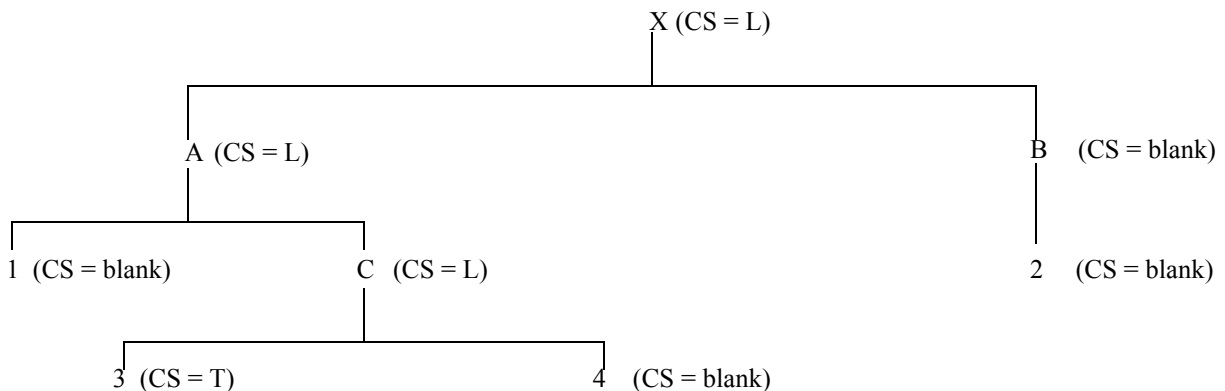

Figure 2-3. Cost Roll-up during Selective Costing

If a change has been made to an item or one of its components since the last costing run, message E AM-4733 ITEM MAY CONTAIN INVALID COST ELEMENTS will appear on the costed inquiries or reports. Either the recost flag or cost status code is not blank. An easy way to “debug” this error is to print the indented costed report for the parent item. The report will print both recost flag and cost status code under the heading “cost codes.” The item in the product structure in error can be found quickly. The items can be selectively recosted to correct any costing problems, but will not reset the recost flag. This error message will continue to appear until a full costing rollup is performed.

Standard batch quantity

Some industries (such as pharmaceutical, paint, chemical, cosmetic, food and beverage, semiconductor, and plastics) structure their bills of material according to a standard batch quantity. The bills of material or product formulations contain the quantity of component material necessary to produce a standard batch of the parent item. Figure 2-4 shows an example of a bill of material structured according to a standard batch quantity.

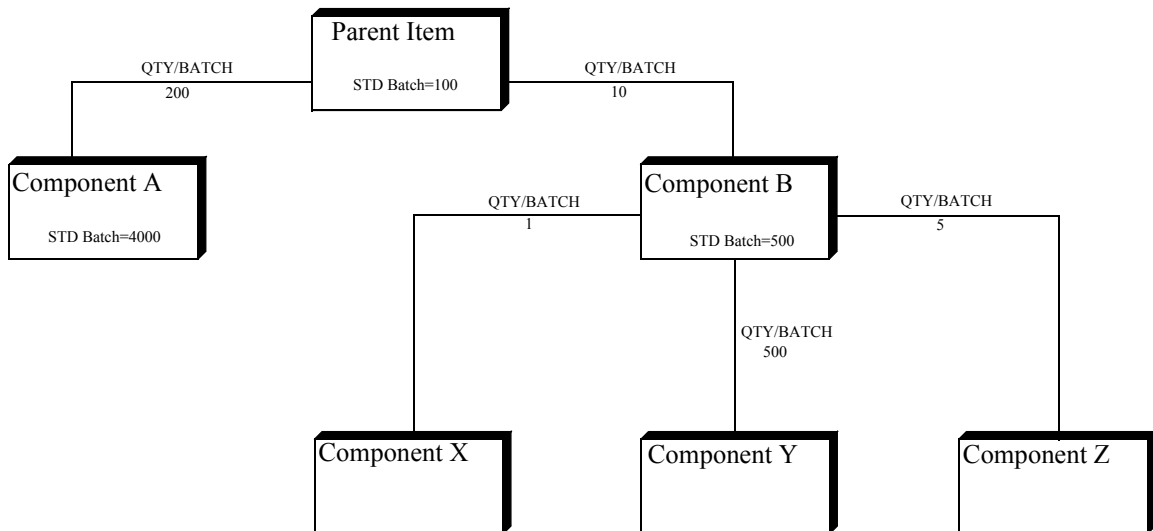

Figure 2-4. A bill of material structured according to a standard batch quantity

This technique can be particularly useful when determining the cost of a small batch requested by a customer or for producing an assay quantity. Bill of material explosions can be performed and the correct quantity of each component calculated at each level.

The formula for determining the correct quantity of each component is shown here:

$$\text{Required qty of component} = \frac{\text{Qty per of component}}{\text{SBQ of parent}} \times \text{Desired qty of parent}$$

The table below shows an example of this technique applied across two levels of the bill of material shown in Figure 2-4.

Bill of material	SBQ of parent	Qty per of comp.	Required Quantity = 1		Required Quantity = 100	
			Required qty of parent	Qty needed of comp.	Required qty of parent	Qty needed of comp.
Level 1 Parent Item	100		1		100	
Component A		200		2		200
Component B		10		.1		10
Level 2 Component B	500		.1		10	
Component X		1		.0002		.02
Component Y		500		.1		10
Component Z		50		.01		1
Note that Component B is a component item on Level 1, and a parent item on Level 2.						

Note: Time values in the routing operations are expressed in terms of a unit of measure of the parent item, regardless of its standard batch quantity.

Operation yield

Operation yield is used primarily by industries where loss occurs as a product moves through each stage or operation. The operation yield is expressed as a percentage of the parent quantity that remains in the production process at the end of the operation compared to what came into the operation. The yield at an operation level has a cumulative effect as the product moves through subsequent operations. It affects the planned operation times and the component or ingredient requirements as they are introduced at future operations.

Operation yield should not be confused with component scrap or component loss. Operation yield is a loss in the parent quantity and component scrap is a loss of an ingredient during an operation. Component loss is typically due to evaporation, spillage, or breakage and is compensated for by increasing the component quantity.

Operation Yield (Standard or Current) is a user-maintained field and cannot exceed 100 percent or be negative. It is stored in the Routing file. Cumulative yield through previous operation (standard or current) and total cumulative yield (standard or current) are calculated when you select option 1 (Calculate Cumulative Yield) from the Yield Calculation menu (AMEM06). Cumulative yield through previous operation is stored in the Routing file and total cumulative yield is stored in the A-record in the Item Master file. The Average Yields are calculated by PC&C, if it is installed and interfacing with PDM.

Note: PC&C uses current yield for manufacturing orders.

The types of operation yield are:

- Operation yield (current, standard, or average)

- Cumulative yield through previous operation (current, standard, or average)
- Total cumulative yield (current, standard, or average).

If you use yields in the Routing file and add or delete routing steps, you must run the calculation yield and adjusted quantity per to update the total cumulative yield stored in the Item Master A-record. (In EPDM these functions are run automatically, as needed.)

Shrinkage

Shrinkage is a value used by MRP and MPSP (if installed and interfacing) as a factor in a division calculation that increases gross requirements based on shrinkage, not covered by on-hand quantity to reflect material losses.

When the shrinkage factor is not zero, MRP calculates the planned order quantity by dividing the required quantity by the difference between 1 and the shrinkage factor. For example, if you require 80 and the shrinkage factor is 20 percent, use the following calculation:

$$80 / (1 - .200) = 100$$

When you order 100 and you scrap 20 percent, you still have 80 remaining to cover the original requirement.

MRP and MPSP consider both shrinkage and adjusted quantity per (which includes operation yield). Therefore, if you are using operation yield, you probably want a shrinkage factor of zero. Only in cases where there is additional loss of the parent item after production is complete, such as testing or breakage in packaging, do you want to use a shrinkage factor as well as a yield factor.

Adjusted quantity per

After the Operation Yield values are specified in the Routing file and the cumulative yields are calculated, the quantity per values should be adjusted to reflect the true material requirements for a component. The Adjusted Quantity Per is calculated for each material at the operation where it is first used when you select option 2 (Calculate Adjusted Quantity Per) from the Yield Calculation menu, AMEM06, using the following formula:

$$\text{Adjusted Quantity Per} = \text{Quantity Per} \times \frac{\text{Cumulative Yield Through Previous Operation}}{\text{Total Cumulative Yield}}$$

The Adjusted Quantity Per and the original, or engineered, Quantity Per are stored in the Product Structure Detail file. (In EPDM these values are not stored.)

A component's Adjusted Quantity Per can be calculated using standard, current, or adjusted yields. Cumulative yields for all operations are stored in the Item Master file, while the operation yields are stored in the Routing operation records. The product cost generations for standard and current costs use standard and current yields; the simulation cost generation gives you an option to use average yield.

In EPDM, cumulative yield for all operations are stored in the Routing header record.

Adjusted run hours

The run hours (machine and labor) in the Routing file are also adjusted to compensate for yield. The Adjusted Run Hours are calculated for each routing operation when run hours are used in PDM Product Costing or in Inventory Management Manufacturing Order Release, using the following formula:

$$\text{Adjusted Run Hours} = \text{Run Hours} \times \frac{\text{Cumulative Yield Through Previous Operation}}{\text{Total Cumulative Yield}}$$

Impact of operation yield on product costing, material requirements, and scheduling

The following example illustrates the difference in calculating your product costs, material requirements, and operation run times when you start using operation yield. The results vary depending on where a material is introduced into the production cycle and the current yield at that operation and subsequent operations.

Without operation yield or if operation yield = 100%. Product A has these characteristics recorded in the following files:

Product Structure:

Component	Quantity Per	Operation Where First Used
B	3	10
C	4	20
D	1	30

Routing:

Operation	Run Hours
10	2.00
20	2.00
30	1.00
40	3.00

The component costs are: B = \$1.00, C = \$.50, D = \$10.00. The Production Facility rates are: Labor = \$10.00, Overhead = 50%. The total material cost for Product A is: \$3.00 + \$2.00 + \$10.00 = \$15.00 per unit.

Assuming that the run hours are all labor, the total labor and overhead costs, using the production facility rates, are:

Operation	Calculation	Labor	Overhead
10	2.00 hrs x \$10.00	\$20.00	\$10.00
20	2.00 hrs x \$10.00	\$20.00	\$10.00
30	1.00 hrs x \$10.00	\$10.00	\$5.00
40	3.00 hrs x \$10.00	\$30.00	\$15.00
	Total	\$80.00	\$40.00

The total unit cost for Product A is: \$15.00 (material) + \$80.00 (labor) + \$40.00 (overhead) = \$135.00.

With standard batch quantity and current operation yield. Since Product A now has a Standard Batch Quantity of 100, the Quantity Per for each component has been multiplied by 100 to reflect the proper relationship to the Standard Batch Quantity rather than to one of the parent. The Product Structure file now contains the Adjusted Quantity Per, which was calculated when option 2 (Calculate Adjusted Quantity Per) on the Yield Calculation menu, AMEM06, was run.

Product Structure:

Component	Quantity Per	Operation Where First Used	Adjusted Quantity Per
B	300	10	833
C	400	20	1111
D	100	30	222

The Routing file now contains current operation yield. After choosing option 1 (Calculate Cumulative Yield) from the Yield Calculation menu (AMEM06), the file also contains cumulative yield through previous operation. The total cumulative yield and the standard batch quantity of 100 are stored in the Item Master A-record. Adjusted Run Hours are calculated when the next Manufacturing Order is released.

Routing:

Operation	Run Hours	Operation Yield	Cumulative Yield Through Previous Operation	Adjusted Run Hours
10	2.00	100%	100%	5.55
20	2.00	80%	100%	5.55
30	1.00	50%	80%	2.22
40	3.00	90%	40%	3.33
Total cumulative yield:			36%	

The total material cost for Product A is: $\$833.00 + \$555.50 + \$3330.00 = \4718.50 per Standard Batch Quantity. The per unit cost is \$47.18. The labor and overhead costs are now:

Operation	Calculation	Labor	Overhead
10	5.55 hrs x \$10.00	\$55.50	\$27.75
20	5.55 hrs x \$10.00	\$55.50	\$27.75
30	2.22 hrs x \$10.00	\$22.20	\$11.10
40	3.33 hrs x \$10.00	\$33.30	\$16.50
	Total	\$166.50	\$83.25

The total unit cost for Product A is now: $\$47.18$ (material) + $\$166.50$ (labor) + $\$83.25$ (overhead) = $\$296.93$.

The following table shows the impact that specifying and tracking operation yield can have on a product's cost, scheduling, and material requirements:

Task	Without Yield	With Yield
Costing:		
Material	\$15.00	\$47.18
Labor	\$80.00	\$166.50
Manufacturing overhead	\$40.00	\$83.25
Unit Total	\$135.00	\$296.93
Scheduling:		
Labor Hours	8	16.65
Material requirements (on a per unit basis):		
Item B	3	8.33
Item C	4	11.11
Item D	1	3.33

Roll Current Costs to Standard Costs

Product Data Management allows you to roll costs from current to standard at any time. Normally, this function is run in preparation for starting a new year. Use option 12 on the Costing menu to perform this function. The cost fields that are rolled include:

- Item Master B-record:
 - This-level and Lower-level cost fields
 - Labor and overhead codes
 - Cost status code
 - Date of last maintenance for the cost fields
 - Date of last cost generation and the type of generation
- Production Facility Master: work center labor/overhead rates and codes
- Product Structure file: Adjusted quantity per
- Routing and Item Master file: Yields

The Recost flag will be updated as follows:

- If the Recost flag is set to recost current (C), the system sets the Recost flag to both (B).
- If the Recost flag is set for a new item that needs current costs recalculated (O), the system sets the flag to both (N).

Foreign language descriptions

Product Data Management allows you to maintain item descriptions using foreign languages in the Item Foreign Language file. You assign language codes to the foreign languages that you use to enter and maintain the item descriptions. An item can have descriptions in as many languages as there are language codes, but each language code can be used for only one description per item. If an item needs to have more than one description in a particular foreign language, you can assign a pseudo-language code to the second description in that language.

The pseudo-language code allows you to type in a description for an item using a foreign language that is already assigned to another language code and already used for another description for that item. For example, if you have customers for an item in both France and Canada, you can distinguish between descriptions used for these customers by entering a language code of FRE for descriptions used with French customers and CFR for descriptions used with French-speaking Canadian customers.

You can also use language codes to have multiple descriptions for an item in your own language. For example, you can set up pseudo-language codes to show your domestic customers' item descriptions along with the descriptions you normally use on inquiries and reports. You assign the pseudo-language codes that you set up for customer item descriptions to those customers in the Customer file in Customer Order Management (COM). See the *Customer Order Management User's Guide* for additional information.

The Item Foreign Language file supports a default language option with default language code 000. This option allows you to set up descriptions for your items in a widely used language using language code 000. You can select the default language for item foreign language description inquiries or for item foreign language description reports. PDM displays or prints the default descriptions along with any foreign language descriptions that fall within the range of language codes used for the inquiry or report. However, the default descriptions also appear in reports on items without foreign language descriptions if you do not choose to exclude them.

Chapter 3. Inquiry

When you select option 1 on the Main Menu (AMEM00), the Inquiry menu (AMEM02) appears. This menu allows you to view information about items, routings, production facilities, features and options, product structures, and foreign language descriptions.

Option 1. Display Item Detail (AMEM02).....	3-3
Option 2. Product Structure Retrievals (AMEM02).....	3-7
Option 3. Single Level Costed (AMEM02).....	3-22
Option 4. Routing (AMEM02).....	3-30
Option 5. Production Facility (AMEM02).....	3-39
Option 6. Feature/Options (AMEM02).....	3-47
Option 7. Feature/Options with S-Number Build (AMEM02).....	3-51
Option 8. Item Foreign Language Descriptions (AMEM02).....	3-56

Note: If you do not select Product Costing, Routing file, Production Facility file, and Feature/Options during application tailoring and you select options 3 through 7, your request is canceled, and the Main Menu (AMEM00) appears again.

```

AMEM02                                Product Data Management          *****
                                Inquiry

Type option or command; press Enter.

    1. Item Master
    2. Product Structure Retrievals
    3. Single Level Costed
    4. Routing
    5. Production Facility
    6. Feature/Options
    7. Feature/Options with S-Number Build
    8. Item Foreign Language Descriptions

==> _____

F3=Exit      F4=Prompt      F9=Retrieve      F10=Actions
F11=Job status  F12=Return      F22=Messages
  
```

Option 1. Display Item Detail. Use this option to view item detail information.

Option 2. Product Structure Retrievals. Use this option to view a particular parent or component item number in several structural formats.

Option 3. Single Level Costed. Use this option to view a single level retrieval with cost fields for a parent item.

Option 4. Routing. Use this option to view the routing operations for an item.

Option 5. Production Facility. Use this option to view a variety of information about your facilities, including variable capacity data.

Option 6. Feature/Options. Use this option to view features and each feature's options for the end-item you enter.

Option 7. Feature/Options with S-Number Build. This option is the same as option 6, except that it also allows you to build an S-number and then perform a retrieval on that number.

You can make inquiries from this menu or from the Group Job menu. Some inquiry options may not be available to you if your company has tailored the standard Group Job menu.

Option 8. Item Foreign Language Descriptions. Use this option to view foreign language descriptions that you have set up for the item number you enter. You can view all foreign language descriptions for an item or descriptions that appear in a particular foreign language or range of languages.

All inquiries require an item number except the Production Facility Inquiry, which requires a facility ID. On many inquiry displays you might see a plus sign (+) in the lower right corner of the display. Use the roll key to see additional information. On the inquiry displays, you can retrieve a different item number or facility ID by typing over the previous number you entered and pressing **Enter**.

Prerequisites

The information shown for items (Item Master file) and facilities (Production Facility file) is the most current information available. However, be aware that changes to bills of material (Product Structure file) and routings (Routing file) may be pending. For example, a new routing or a replaced component may have been entered but not processed yet to update the files, and therefore does not yet appear on the inquiry display.

Option 1. Display Item Detail (AMEM02)

Use this option anytime you want to see information about an item in the Item Master file. This option takes you to the Item Detail panels within the Work With Items function.

For detailed information about how to use the work with lists, see *Working with Infor ERP XA*. For navigation information on work with lists and options, see the *Inventory Management User's Guide*.

Note: You see information in an item's B-record only if product costing was selected during application tailoring or if the full version of Material Requirements Planning is installed and interfacing. You see information in an item's C-record only if Purchasing is installed.

What information you need: The item number of each item for inquiry.

What reports are printed: None.

What forms you need: None

AMVDIM00—Specify Item to Display

Use this panel to select the item detail you want to see.

This panel appears when you select option 1, Display Item Detail, on the PDM Inquiry menu (AMEM02); option 2, Item Master, on the Purchasing Inquiry menu (AM6M30) or option 1, Item Master, on the IM Inquiry menu (AMIM10).

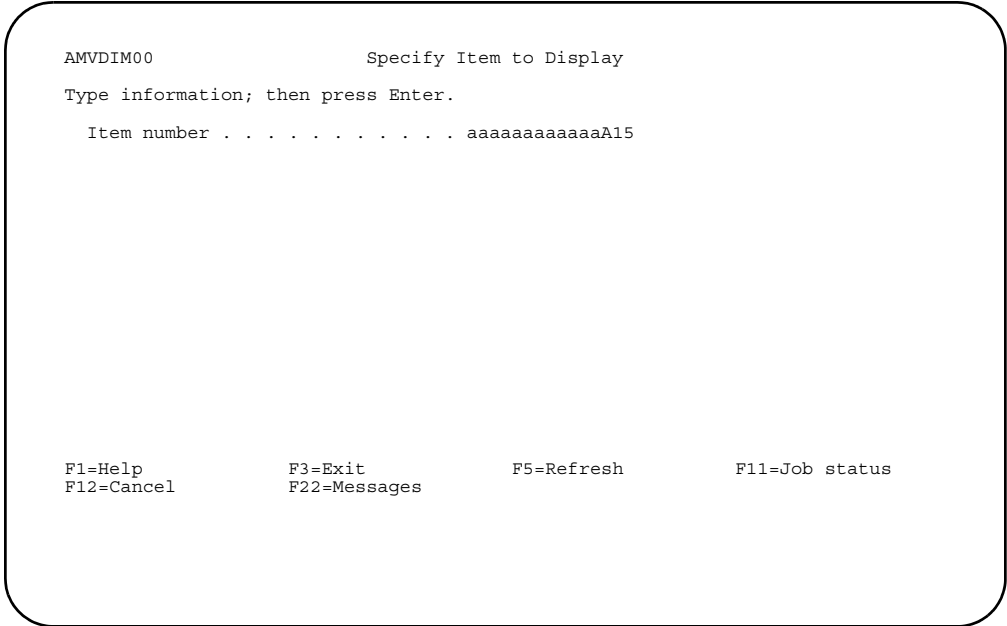

What to do

To display details about an item, type the item number and press **Enter**. Panel AMVDIM01 appears.

Function keys

F3=Exit causes the Inquiry menu to appear again.

F5=Refresh resets the entry field to blank.

F11=Job status shows a list of your current system and job information.

F12=Cancel returns to the previous panel.

F22=Messages shows a list of all the messages currently sent to this panel.

Fields

ITEM (ITNBR). Required. Type in the number of the item whose details you want to see.

AMVDIM01—Display Item Detail

Use this panel to review detailed information for the item you selected. The pages of information appear in the following order unless you change the order on the Change Defaults panel (AMVDIM02):

- Item characteristics
- Engineering information
- Location control information
- Sales information
- Master scheduling information
- Costing parameters
- Costing summary
- Standard cost information
- Current cost information
- Purchasing information
- Vendor performance information
- Shipping information
- Costing maintenance dates

This panel appears when you type option 5 next to an item number on the Work With Items panel (AMVWIM01).

```

AMVDIM01                Display Item Detail
Item number . . . . . *****
To select a page, type page and press Enter, or press Enter to continue.
                                                    Page 1 of 12
Item characteristics
Item type . . . . . : *
Value class . . . . . : *
Inventory flag . . . . . : **
Department number . . . . . : ****
Accounting class . . . . . : ***
Default stock location . . . . . : *****
Stocking unit of measure . . . . . : ** *****
Carrying rate . . . . . : .***
Country of origin . . . . . : ***

F1=Help          F3=Exit          F5=Refresh      F24=More keys
F7=Backward     F8=Forward       F12=Cancel

F10=Header options  F11=Job status  F18=Change defaults  F22=Messages
                                                            F24=More keys
  
```

What to do

To find specific information, page forward to the category of information you want, or type the page number in the **Page n of n** field, and press **Enter**. The appropriate page appears.

Function keys

F3=Exit causes the Inquiry menu to appear again.

[Contents](#)

[Index](#)

F18=Change defaults causes the Change Defaults panel (AMVWIM02) to appear so you can change the order in which you see pages of information on the Display Item Detail panel.

Use online help to understand the other function keys.

Fields

Online help is available for all the fields on the panels. You also can refer to AMVT02, AMVT03, AMVT04, and AMVT05 in this manual for field descriptions.

[Contents](#)

[Index](#)

Option 2. Product Structure Retrievals (AMEM02)

Use this option anytime you want to see the information about an item in the Product Structure file.

What information you need: The item number for each item you want to see.

What reports are printed: None.

What forms you need: None.

AMEC70—Product Structure Retrievals (Select)

Use this display to select the item number (and optionally the quantity per and S-number) and the type of product structure to appear.

This display appears when you select option 2, Product Structure Retrievals, on the Inquiry menu (AMEM02).

This display lets you select, by item number, the bill of material you want to see. You can see this item's product structure (bill of material) in four ways: single level, indented, single level where-used, or single level bill with blow-through, which means it shows the feature's options and the phantom's components. These four ways or actions are listed (action = 1, 2, 3, or 4) on this display and you can select the one you want. You can also enter the S-number (options for that item's features) and a quantity.

```

DATE **/**/**          PRODUCT STRUCTURE RETRIEVALS          SELECT          AMEC70  **

                                     ENTER -
                                     ACTION  A
                                     ITEM    aaaaaaaaaaaaaA15
                                     QTY     nnnnnnnn
                                     S-NO.   aaaaaaaaaaaaaaaaaA20

                                     APPLIES
                                     TO-
                                     ALL
                                     1,2,4
                                     2,4

SELECT ONE OF THESE ACTIONS -
1 - SINGLE LEVEL BILL
2 - INDENTED BILL
3 - SINGLE LEVEL WHERE-USED
4 - SINGLE LEVEL BILL WITH BLOW-THRU

                                     F24 END OF JOB
    
```

What to do

- To inquire about a item's single-level bill of material, type **1** in the **ACTION** field, the item number, and any optional information you choose. Press **Enter** and go to display AMEC71.
- To inquire about an item's indented bill of material, type **2** in the **ACTION** field, the item number, and any optional information you choose. Press **Enter** and go to display AMEC72.
- To inquire about an item's single-level where-used, type **3** in the **ACTION** field, the item number, and any optional information you choose. Press **Enter** and go to display AMEC73.
- To inquire about an item's single-level bill of material with blow-through, type **4** in the **ACTION** field, the item number, and any optional information you choose. Press **Enter** and go to display AMEC74.

Function keys

F24 END OF JOB causes the Inquiry menu (AMEM02) to appear again.

Fields

[?] appears next to a field name in the following field definitions to identify a field from which you can begin a master file search.

ACTION. Required. Type in the number (1-4) shown in the lower left of the display that corresponds to the type of product structure you want to see.

ITEM (ITNBR) [?]. Required. Type in the number of the item whose product structure you want to see.

QTY (Quantity). Type in a quantity of up to 99,999,999 to indicate how many units of the item you want to see. For example, if the standard batch quantity is 100 and you want to see 900 units, type in 900. The default is 1. If you type a 3 in the **ACTION** field, Single Level Where-Used, on this display, the QTY field is ignored and a quantity of 1 is assumed.

S-NO. [?]. If features and options were selected during application tailoring, S-NO. (S-number) appears on the display. If you select Action 2 (Indented Bill) or Action 4 (Single Level Bill with Blow-Through) and the item you entered is an end-item, you can enter an S-number of up to 20 alphanumeric characters containing option numbers for known features. Only those specific features and options called by the S-number appear.

If you enter a zero or blanks in the S-NO. field for a nonrequired feature, that feature and its associated options do not appear.

Asterisk(s) in the **S-NO.** field are valid entries and cause all options of the respective feature to appear.

AMEC71—Single Level Bill of Material (Inquiry)

Use this display to review detailed information for the first level down in the bill of material for the parent item number entered. The detail includes: user sequence (if applicable), a description of each component in that lower level, quantity, unit of measure, engineering drawing number, and the first operation where-used in the routing.

This display appears when you type action 1 (single level bill) and a valid item number on the Product Structure Retrievals (Select) display (AMEC70).

```

DATE **/**/**          SINGLE LEVEL BILL OF MATERIAL      INQUIRY      AMEC71  **
ITEM aaaaaaaaaaaaA15          UM ** I/T *  *****
LLC  **          QTY nnnnnnnn  SBQ **,**,**.*** ENG. DRAWING *****
LLC SEQ COMPONENT          QTY PER  UM IT FROM / TO  ENG. DRAWING 1ST OPER
      DESCRIPTION
** **** *****          *****_*** ** * **/**/** ***** ****
      *****          *****          **/**/**
** **** *****          *****_*** ** * **/**/** ***** ****
      *****          *****          **/**/** **PHANTOM**
** **** *****          *****_*** ** * **/**/** ***** ****
      *****          *****          **/**/**
** **** *****          *****_*** ** * **/**/** ***** ****
      *****          *****          **/**/**
** **** *****          *****_*** ** * **/**/** ***** ****
      *****          *****          **/**/** **PHANTOM**
** **** *****          *****_*** ** * **/**/** ***** ****
      *****          *****          **/**/**

                                USE ROLL UP/DOWN      +
                                F19 RETURN TO SELECT
                                F24 END OF JOB

```

What to do

- To look at the information for another item, type the item number in the **ITEM** field and any optional information you choose. Press **Enter**. This display appears again with the single-level bill of material for the new item.
- To look at an item’s indented bill of material, single-level where-used, or single-level bill of material with blow-through, use **F19**. Go to display AMEC70.

Function keys

USE ROLL UP/DOWN allows you to scroll forward through the list on the display.

F19 RETURN TO SELECT causes display AMEC70 to appear again.

F24 END OF JOB causes the Inquiry menu (AMEM02) to appear again.

Fields

[?] appears next to a field name in the following field definitions to identify a field from which you can begin a master file search.

ITEM (ITNBR) [?]. When you have completed reviewing this item's single level product structure, type in the next item number whose single level structure you want to see.

UM (Unit of Measure) (UNMSR). The code (user assigned) that identifies the measurement basis of onhand and issue quantity for this ITEM; for example, EA (each), KG (kilogram), or CM (centimeter).

I/T (Item Type Code) (ITYP). The item type code that best describes the item.

0	Phantom
1	Assembly or subassembly
2	Fabricated item
3	Raw material
4	Purchased item
9	User option
F	Feature.

Description (ITDSC). This field appears to the right of the field I/T and has no heading. It shows the description of the item that normally appears on invoices, inquiries, and reports.

LLC (Low-Level Code) (LOLEV). The lowest level in any product structure where this item is used; for example, a parent item has a low-level code of 00; a feature to that parent has a low-level code of 01; an option to that feature has a low-level code of 02.

QTY (Quantity). Type in a quantity of up to 99,999,999 to indicate how many units of the item you want to see. For example, if the standard batch quantity is 100 and you want to see 900 units, type in 900.

The following fields are informational only. The fields that apply to both the parent item and the component item (UM, I/T, Description, LLC, and ENG. DRAWING) are defined only once. The first two lines of data following the display title apply to the parent item that you entered. The remaining lines of data apply to the component items of that parent.

SBQ (Standard Batch Quantity) (SBQTY). The quantity of the parent item relative to the quantity of each component item. The product structure (recipe or formulation) is expressed in relation to a batch quantity of the parent item as opposed to a quantity of one stocking unit.

ENG. DRAWING (Engineering Drawing Number) (ENGNO). The number of the engineering drawing that defines this item.

SEQ (Component User Sequence) (USRSQ). The user-designated sequence number for this component. The number is used to establish the sequence of the bills of material. This field appears only if the user-sequence function was chosen during application tailoring.

QTY PER (QTYPR). The quantity of the component item used to produce the amount of the parent item you specified in the QTY field. This quantity is adjusted by the standard batch quantity.

[Contents](#)

[Index](#)

FROM / TO (EDATM, EDATO) . The range of effectivity dates for this component item; for example, component X might be used in the manufacture of parent item Y from 1/23/** to 12/23/**.

Component X is included in parent item Y's structure if the effectivity date of this inquiry is earlier than the TO date, 12/23/** (EDATO), and equal to or later than the FROM date, 1/23/** (EDATM).

1ST OPER (First Routing Operation) (OPWFU). The operation where this component is first used in manufacturing the parent item.

AMEC72—Indented Bill of Material (Inquiry)

Use this display to review the entire product structure of the parent item number in indented format.

This display appears when ACTION 2 (Indented Bill) and a valid item number are entered on display AMEC70.

This display appears only if you chose action 2: indented bill on display AMEC70. If you also entered an S-number for an end item with features, the options for the features are retrieved as specified in the S-number. If the S-number is left blank for an end item with features, then all the options for that end item's features are shown. It shows the entire product structure of the entered parent item number in indented format. The relative level shown in the left column of the display indicates the levels in the bill of material for this parent item relative to the parent's level. For example, if you select an item with a low level code of 10, the indented bill for that item starts with a relative level of 1 even though the low level code could be 11 or greater. Shown with each level are the item numbers of the components, extended quantities, unit of measure, effective dates (from and to), a shortened description, and the S-number entered.

```

DATE **/**/**          INDENTED BILL OF MATERIAL          INQUIRY    AMEC72  **
ITEM aaaaaaaaaaaaA15          UM ** I/T * *****
S-NO. aaaaaaaaaaaaaaaaaA20 ENG. DRAWING *****
RELATIVE COMPONENT          QTY PER          SBQ **,**,***,***.***
LEVEL ITEM NUMBER          QTY PER          UM IT FROM / TO DESCRIPTION-TRUNC.
1 ***** ** ***** ** * ***** *****
1 ***** FEATURE ** ***** *****
.2 0-** ***** ** * ***** *****
.2 0-** ***** ** * ***** *****
1 ***** ** * ***** *****
.2 ***** ** * ***** *****
. .3 ***** ** * ***** *****
. .4 ***** ** * ***** *****
. .4 ***** ** * ***** *****
. .3 ***** ** * ***** *****
.2 ***** ** * ***** *****
1 ***** FEATURE ** ***** *****
.2 0-** ***** ** * ***** *****
.2 0-** ***** ** * ***** *****
.2 0-** ***** ** * ***** *****
USE ROLL UP/DOWN          +
F19 RETURN TO SELECT
F24 END OF JOB
    
```

What to do

- To look at the information for another item, type the item number in the *ITEM* field and any optional information you choose. Press **Enter**. This display appears again with the indented bill of material for the new item.
- To look at an item's single-level where-used, single-level bill of material with blow-through, or single-level bill of material, use **F19**. Go to display AMEC70.

Function keys

USE ROLL UP/DOWN allows you to scroll forward and backward through the list on the display.

F19 RETURN TO SELECT causes display AMEC70 to appear again.

F24 END OF JOB causes the Inquiry menu (AMEM02) to appear again.

Fields

[?] appears next to a field name in the following field definitions to identify a field from which you can begin a master file search.

ITEM (ITNBR) [?]. When you have completed reviewing the indented bill for the parent item you entered, type in the next parent item number whose indented bill you want to see. You can also enter a quantity used for this item and, if the item has features, an S-number.

UM (Unit of Measure) (UNMSR). The code (user assigned) that identifies the measurement basis of onhand and issue quantity for this item; for example, EA (each), KG (kilogram), or CM (centimeter).

I/T (Item Type Code) (ITYP). The item type code that best describes the item.

0	Phantom
1	Assembly or subassembly
2	Fabricated item
3	Raw material
4	Purchased item
9	User option
F	Feature.

Description (ITDSC). This field appears to the right of the field I/T and has no heading. It shows the description of the item that normally appears on invoices, inquiries, and reports.

S-NO (S-number) [?]. If feature/options was selected during application tailoring, the S-NO. field appears on the display. If the item you entered is an end-item with features, you can enter an S-number of up to 20 alphanumeric characters containing option numbers for known features.

If the item you entered is an end-item with features and you leave the asterisks in the S-NO. field, all features and their associated options for that end-item appear.

ENG. DRAWING (Engineering Drawing Number) (ENGNO). The number of the engineering drawing that defines this item.

QTY (Quantity) (QTY). Type in a quantity of up to 99,999,999 to indicate how many units of the item you want to see. For example, if the standard batch quantity is 100 and you want to see 900 units, type in 900.

The following fields are informational only. Those fields (UM and I/T) that apply to both the parent item and the component items are defined only once. The first two lines of data following the display title apply to the parent item that you entered. The remaining lines of data apply to the component items of that parent.

SBQ (Standard Batch Quantity) (SBQTY). The quantity of the parent item relative to the quantity of each component item. The product structure (recipe or formulation) is expressed in relation to a batch quantity of the parent item as opposed to a quantity of one stocking unit.

RELATIVE LEVEL. The number used to indicate the relative levels within the bill of material of one component item to another and of all component items to the parent item; for example, any component item having a relative level of .1 would be a direct component of the item selected for the inquiry. Any component having a relative level of .2 would be a direct component of the .1 component shown above.

COMPONENT ITEM NUMBER (ITNBR). The number that uniquely identifies the component of the parent item shown above.

QTY PER (Quantity Per Item) (QTYPR). The quantity of the component item used to produce the amount of the parent item you specified in the QTY field. This quantity is adjusted by the standard batch quantity.

FROM / TO (EDATM, EDATO). The range of effectivity dates for this component item; for example, component X might be used in the manufacture of parent item Y from 1/23/** to 12/23/**. Component X is included in parent item Y's structure if the effectivity date of this inquiry is earlier than the TO date, 12/23/** (EDATO), and equal to or later than the FROM date, 1/23/** (EDATM).

DESCRIPTION-TRUNC. (Truncated description) (ITD20). An abbreviated version of the normal description.

AMEC73—Single Level Where-Used (Inquiry)

Use this display to review information for parent items only one level up in the bill of material for the entered component item.

This display appears when you type action 3 (single level where-used) and a valid item number on display AMEC70.

This display appears only if you chose action 3: single level where-used on display AMEC70. It shows information for parent items only one level up in the bill of material for the entered component item. This display shows the parents using this item, their descriptions, unit of measure, effective date (from and to), engineering drawing number, first operation where-used in the routing (if applicable), and user sequence (if applicable).

```

DATE **/**/**          SINGLE LEVEL WHERE-USED          INQUIRY    AMEC73  **
ITEM aaaaaaaaaaaaA15    UM **  I/T *  *****
LLC **                 SBQ **,**,***,**.***  ENG. DRAWING *****
LLC   PARENT           QTY PER  UM IT FROM / TO      1ST OPER  SEQ
   DESCRIPTION                                ENG. DRAWING
**   *****.*** ** * **/**/** **/**/** ****
   ***** **PHANTOM** *****
**   *****.*** ** * **/**/** **/**/** ****
   ***** **PHANTOM** *****
**   *****.*** ** * **/**/** **/**/** ****
   ***** **PHANTOM** *****
**   *****.*** ** * **/**/** **/**/** ****
   ***** **PHANTOM** *****
**   *****.*** ** * **/**/** **/**/** ****
   ***** **PHANTOM** *****
**   *****.*** ** * **/**/** **/**/** ****
   ***** **PHANTOM** *****
**   *****.*** ** * **/**/** **/**/** ****
   ***** **PHANTOM** *****
**   *****.*** ** * **/**/** **/**/** ****
   ***** **PHANTOM** *****
**   *****.*** ** * **/**/** **/**/** ****
   ***** **PHANTOM** *****

                                 USE ROLL UP      +
                                 F19 RETURN TO SELECT
                                 F24 END OF JOB

```

What to do

- To look at the information for another item, type the item number in the **ITEM** field and any optional information you choose. Press **Enter**. This display appears again with the single-level where-used for the new item.
- To look at an item’s indented bill of material, single-level bill of material with blow-through, or single-level bill of material, use **F19**. Go to display AMEC70.

Function keys

- USE ROLL UP allows you to scroll forward through the list on the display.
- F19 RETURN TO SELECT causes display AMEC70 to appear again.
- F24 END OF JOB causes the Inquiry menu (AMEM02) to appear again.

Fields

[?] appears next to a field name in the following field definitions to identify a field from which you can begin a master file search.

ITEM (ITNBR) [?]. When you finish reviewing the parent item of this component (direct usages), type in the next component item for viewing.

The following fields are informational only. Those fields (UM, I/T, Description, LLC, and ENG. DRAWING) that apply to both the component item and the parent items are defined only once. The first two lines of data following the display title apply to the component item that you entered. The remaining lines of data apply to the parent items using that component.

UM (Unit of Measure) (UNMSR). The code (user assigned) that identifies the measurement basis of onhand and issue quantities for this item; for example, EA (each), KG (kilogram), or CM (centimeter).

I/T (Item Type Code) (ITYP). The item type code that best describes the item.

0	Phantom
1	Assembly or subassembly
2	Fabricated item
3	Raw material
4	Purchased item
9	User option
F	Feature.

Description (ITDSC). This field appears to the right of the field I/T and has no heading. It shows the description of the item that normally appears on invoices, inquiries, and reports.

LLC (Low-Level Code) (LOLEV). The lowest level in any product structure that this item is used. For example, a parent item has a low-level code of 00; a feature to that parent has a low-level code of 01; and an option to that feature has a low-level code of 02.

SBQ (Standard Batch Quantity) (SBQTY). The quantity of the parent item relative to the quantity of each component item. The product structure (recipe or formulation) is expressed in relation to a batch quantity of the parent item as opposed to a quantity of one stocking unit.

PARENT (Parent Item Number) (PINBR). The item number of the parent item.

ENG. DRAWING (Engineering Drawing Number) (ENGNO). The number of the engineering drawing that defines this item.

DESCRIPTION (Parent Item Description) (ITDSC). The description of the parent item associated with this component item.

QTY PER (QTYPR). The quantity of the component item used to produce one unit of the parent item. This quantity is adjusted by the standard batch quantity.

FROM / TO (EDATM, EDATO). The range of effectivity dates for this component item; for example, component X might be used in the manufacture of parent item Y from 1/23/** to 12/23/**.

[Contents](#)

[Index](#)

Component X is included in parent item Y's structure if the effectivity date of this inquiry is earlier than the TO date, 12/23/** (EDATO), and equal to or later than the FROM date, 1/23/** (EDATM).

1ST OPER (First Routing Operation) (OPWFU). The first routing operation using this component during parent item manufacture.

SEQ (User Sequence) (USRSQ). The user-designated sequence number of the component for a parent item.

AMEC74—Single Level Bill With Blow-Through (Inquiry)

Use this display to review a single level bill with blow-through.

This display appears when you type action 4 (single level bill with blow-through) and a valid item number are entered on display AMEC70.

This display appears only if you chose action 4: single level bill with blow-through. It shows for the end item entered, the option items for each feature as specified by the S-number and the component items for each phantom. This display shows user sequence (if applicable), item description, extended quantity, unit of measure, effective dates (from and to), engineering drawing number, option number (if applicable), cost roll-up factor, and planning factor. This inquiry works like the single level inquiry except that options of features and components for phantoms are shown. This inquiry can provide a single level picking list for end items with features or any item with phantoms.

```

DATE **/**/**          SINGLE LEVEL BILL WITH BLOW-THROUGH          INQUIRY          AMEC74  **
ITEM aaaaaaaaaaaA15 QTY nnnnnnnn UM ** IT * ****
LLC ** SBQ **,***,**.*** SNO aaaaaaaaaaaaaaaaaaA20 ENG. DRAWING *****
LLC SEQ COMPONENT          QTY PER          UM IT FROM / TO          ENG. DRAWING          OPER
          DESCRIPTION          CD-NO          C-FCTR          P-FCTR
** **** *****
** **** ***** ** * ***** ***** *****
** **** ***** ** * ***** ***** *****
** **** ***** ** * ***** ***** *****
** **** ***** ** * ***** ***** *****
** **** ***** ** * ***** ***** *****
** **** ***** ** * ***** ***** *****
** **** ***** ** * ***** ***** *****
** **** ***** ** * ***** ***** *****
** **** ***** ** * ***** ***** *****
** **** ***** ** * ***** ***** *****
** **** ***** ** * ***** ***** *****
                USE ROLL UP          +
                F19 RETURN TO SELECT
                F24 END OF JOB

```

What to do

- To look at the information for another item, type the item number in the *ITEM* field and any optional information you choose. Press **Enter**. This display appears again with the single-level bill with blow-through for the new item.
- To look at an item’s indented bill of material, single-level where-used, or single-level bill of material, use **F19**. Go to display AMEC70.

Function keys

USE ROLL UP allows you to scroll forward through the list on the display.
F19 RETURN TO SELECT causes display AMEC70 to appear again.
F24 END OF JOB causes the Inquiry menu (AMEM02) to appear again.

Fields

[?] appears next to a field name in the following field definitions to identify a field from which you can begin a master file search.

ITEM (ITNBR) [?]. When you have completed reviewing the single level bill with blow-through for the parent item you entered, type in the next parent item whose single level bill you want to see.

QTY (Quantity) (QTY). Type in a quantity of up to 99,999,999 to indicate how many units of the item you want to see. For example, if the standard batch quantity is 100 and you want to see 900 units, type in 900.

UM (Unit of Measure) (UNMSR). The code (user assigned) that identifies the measurement basis of onhand and issue quantity for this item; for example, EA (each), KG (kilogram), or CM (centimeter).

IT (Item Type Code) (ITTYP). The item type code that best describes the item.

0	Phantom
1	Assembly or subassembly
2	Fabricated item
3	Raw material
4	Purchased item
9	User option
F	Feature.

Description (ITDSC). This field appears to the right of the I/T field and has no heading. It shows the description of the item that normally appears on invoices, inquiries, and reports.

LLC (Low-Level Code) (LOLEV). The lowest level in any product structure that uses this item; for example, a parent item has a low-level code of 00; a feature to that parent has a low-level code of 01; and an option to that feature has a low-level code of 02.

SBQ (Standard Batch Quantity) (SBQTY). The quantity of the parent item relative to the quantity of each component item. The product structure (recipe or formulation) is expressed in relation to a batch quantity of the parent item as opposed to a quantity of one stocking unit.

SNO (S-number) [?]. If features and options were selected during application tailoring, the SNO field appears on the display. If the item you entered is an end-item, you can enter an S-number of up to 20 alphanumeric characters containing option numbers for known features.

If the item you entered is an end-item and you leave the asterisks in the SNO field, all features and their associated options for that end-item appear.

The following fields are informational only. Those fields (UM, I/T, Description, LLC, and ENG DRAWING) that apply to both the parent item and the component item are defined only once. The first two lines of data following the display title apply to the parent item that you entered. The remaining lines of data apply to either components of the parent or options of features of the parent.

ENG. DRAWING (Engineering Drawing Number) (ENGNO). The number of the engineering drawing that defines this item.

SEQ (User Sequence) (USRSQ). The user-designated sequence number for this component. The number is used to establish the sequence of the bills of material. This field appears only if the user sequence function was chosen during application tailoring.

COMPONENT DESCRIPTION. The description of the component item associated with this parent item.

QTY PER (Quantity Per Item) (QTYPR). The quantity of the component item used to produce the amount of the parent item you specified in the QTY field.

FROM / TO (EDATM, EDATO). The range of effectivity dates for this component item; for example, component X might be used in the manufacture of parent item Y from 1/23/** to 12/23/**.

Component X is included in parent item Y's structure if the effectivity date of this inquiry is earlier than the TO date, 12/23/** (EDATO), and equal to or later than the FROM date, 1/23/** (EDATM).

OPER (First Routing Operation) (OPWFU). The first routing operation calling for this component during parent item manufacture.

CD-NO. This field is a combination of the following two fields:

FEATURE/OPTION CODE (FOPCD): This field shows one of the following codes:

blank	Component is neither a feature nor an option.
N	Component is a non-required feature; parent is an end-item.
O	Component is an option; parent is a feature.
R	Component is a required feature; parent is an end-item.

FEATURE/OPTION NUMBER (FOPNO): This field shows either the feature or the option number of this component. This field can have a nonzero value only when the feature/option code (see above) is N, O, or R.

C-FCTR (Feature/Option Cost Roll factor) (FOPCF). This factor indicates to PDM's product costing what portion of the component (option) cost is to be rolled-up into the parent's (feature's) cost fields. This field can have a nonzero value only when the Feature/Option code (see above) is O and product costing is installed and interfacing.

P-FCTR (Feature/Option Planning Factor) (FOPPF). This factor indicates to MRP's planning run the average portion of the finished items built with this option. This field can have a nonzero value only when the Feature/Option code (see above) is O.

Option 3. Single Level Costed (AMEM02)

Use this option anytime you want to see costed information about an item in the Product Structure file.

Note: You can see costed information only if product costing was selected during application tailoring.

What information you need: The item number for each item whose costed bill of material you want to see.

What reports are printed: None.

What forms you need: None.

AMEC40—Single Level Costed (Select)

Use this display to select the item number, costing type, (and optionally the quantity, effective date, and S-number) to be presented in the single level costed bill of material.

This display appears when you select option 3 on the Inquiry menu (AMEM02).

```
DATE **/**/**          SINGLE LEVEL COSTED          SELECT          AMEC40 **

ENTER -
ACTION      A
ITEM        aaaaaaaaaaaaaA15
QTY         nnnnnnnn
S-NO.       aaaaaaaaaaaaaaaaaA20
EFFEC-DATE  nnnnnn

SELECT ONE OF THESE ACTIONS -
1 - CURRENT COSTS
2 - STANDARD COSTS

F24 END OF JOB
```

What to do

- To inquire about this item's single level current costed bill of material, type in the item number, **1** in the **ACTION** field, and any optional information you choose. Press **Enter**. Go to display AMEC41.
- To inquire about this item's single level standard costed bill of material, type in the item number, **2** in the **ACTION** field, and any optional information you choose. Press **Enter**. Go to display AMEC42.

Function keys

F24 END OF JOB causes the Inquiry menu (AMEM02) to appear again.

Fields

[?] appears next to a field name in the following field definitions to identify a field from which you can begin a master file search.

ACTION. Required. Type in either 1 for current or 2 for standard costs.

ITEM (ITNBR) [?]. Required. Type in the number of the item whose single level costed bill of material you want to see.

QTY (Quantity) (QTY). You can type in a quantity of up to 99,999,999 to indicate how many units of the item you want to see. For example, if the standard batch quantity is 100 and you want to see 900 units, type in 900. The default is 1.

S-NO. (S-number) [?]. If feature/options was selected during application tailoring, the S-NO. field appears on the display. If the item you entered is an end-item with features, you can enter an S-number of up to 20 alphanumeric characters containing option numbers for known features. Only those specific features and options called by the S-number appear.

If you enter a zero or blanks in the S-NO. field for a nonrequired feature, that feature and its associated options do not appear.

The S-NO. field is a required field if the end-item has at least one required feature.

Asterisk(s) in the S-NO. field are not valid entries on this display.

EFFEC-DATE (Effective Date). Type in an effective date to use the effective dates in the file. If no date is entered, the date last costed (current or standard) is assumed.

AMEC41—Single Level Costed—Current (Inquiry)

Use this display to review the current costs associated with this parent item's single level product structure.

This display appears when you type action 1 (current costs) and a valid item number on display AMEC40.

This display shows the current costs associated with this parent item's product structure. It shows the parent item's description, quantity entered, unit of measure, item type, item class, date last costed, effective date, S-number entered, and the extended costs for all cost elements, and total costs. For all components making up that parent, it shows: user sequence (if applicable), description, extended quantity, unit of measure, item type, item class, extended costs for all cost elements, and total this level costs.

The summary cost element titles that appear in this illustration are the XA default headings. The actual titles depend on the titles that were entered in the PDM Control file.

```

DATE **/**/**      SINGLE LEVEL COSTED - CURRENT      INQUIRY  AMEC41  **
EFFECTIVE nnnnnn   QTY nnnnnnnn      PURCHASE*****
ITEM aaaaaaaaaaaaA15      U/M **      PUR-OVERHEAD*  *****
S-NO. aaaaaaaaaaaaA20      LABOR*****  *****
DESC *****      LAB-OVERHEAD*  *****
LAST COSTED **/**/**      TOTAL      *****
SBQ *****      ITYPE *      ICLASS ****      RECAST FLAG *      COST STATUS *
SEQ COMPONENT      QTY PER      PURCHASE*****      LABOR*****
      DESC (TRUNC)      I/T I/C U/M      PUR-OVERHEAD*      LAB-OVERHEAD*
*****
OPT ** *****      *      *      *      *      *      *      *      *
TOTAL: *****
*****
OPT ** *****      *      *      *      *      *      *      *      *
TOTAL: *****
COMPONENTS SUB TOTAL *****
*****
COMPONENTS TOTAL COST: *****
THIS LEVEL ITEM COST: *****
TOTAL ITEM COST: *****

USE ROLL UP
F07 STANDARD COSTS
F24 END OF JOB
    
```

What to do

- To look at the information for another item, type the item number in the **ITEM** field and any optional information you choose. Press **Enter**. This display appears again with the single-level current costed bill of material for the new item.
- To see this item's standard costs, use **F07**. Go to display AMEC42.

Function keys

USE ROLL UP allows you to scroll forward through the list on the display.

F07 STANDARD COSTS causes display AMEC42 to appear.

F24 END OF JOB causes the Inquiry menu (AMEM02) to appear again.

Fields

[?] appears next to a field name in the following field definitions to identify a field from which you can begin a master file search.

Four fields on this display, EFFECTIVE DATE, QTY, ITEM, and S-NO. are optional. The remaining fields are informational only.

EFFECTIVE. Type in an effective date to use the effective dates in the file. If no date is entered, the date last costed, current or standard (CURDT or STDDT), is assumed.

QTY (Quantity). Type in a quantity of up to 99,999,999 to indicate how many units of the item you want to see. For example, if the standard batch quantity is 100 and you want to see 900 units, type in 900.

ITEM (ITNBR) [?]. When you have completed reviewing the current costed single level product structure for the parent item entered, type in the next parent whose current costed single level bill you want to see.

U/M (Unit of Measure) (UNMSR). The code (user assigned) that identifies the measurement basis of on hand and issue quantity for this item; for example, EA (each), KG (kilogram), or CM (centimeter).

S-NO. [?]. If feature/options was selected during application tailoring, the S-NO. field appears on the display. If the item you entered is an end-item with features, you can type in an S-number of up to 20 characters containing option numbers for known features.

If you enter a zero or blanks in the S-NO. field for a nonrequired feature, that feature and its associated options do not appear. Asterisk(s) in the S-NO. field are not valid entries on this display.

All the other fields on this display are informational only. The fields that apply to both the parent and component items (UM, I/T or Item Type, I/C or Item Class, Material, Labor, Overhead, and Total) are described only once. The first five lines of data following the display title apply to the parent item. The remaining lines of data apply to the component items of that parent.

DESC (ITDSC). The description of the parent item that normally appears on invoices, inquiries, and reports.

LAST COSTED (CURDT, STDDT). The date that this item was last costed using PDM's full product costing.

Note: These fields are contained in the PDMREC record of the SYSCTL file.

SBQ (Standard Batch Quantity) (SBQTY). This field shows the quantity of the parent item relative to the quantity of each component item. The product structure (recipe or formulation) is expressed in relation to a batch quantity of the parent item as opposed to a quantity of one stocking unit.

ITYPE (Item Type Code) (ITTYP). The item type code that best describes the item.

0 Phantom

1	Assembly or subassembly
2	Fabricated item
3	Raw material
4	Purchased item
9	User option
F	Feature.

ICLASS (ITCLS). The code (user assigned) that describes the classification to which this item belongs; for example, ST might be used to code all items made of steel.

RECAST FLAG (RCFLG). One of the following codes that identifies the manufacturing costs (current, standard, or both) that need costing for this item.

blank The item does not need costing.

C The item needs current costing.

S The item needs standard costing.

B The item needs current and standard costing.

N This is a new item and needs current and standard costing.

O This is a new item and needs current costing.

P This is a new item and needs standard costing.

COST STATUS (CSTAC). One of the following codes that identifies the status of this item's current costs after product costing:

blank All costs are complete.

D The item's product structure, routing, or both is inconsistent with its item type.

T Some of the item's this-level costs are inconsistent with its item type.

L Some of the item's lower-level costs are inconsistent with its item type.

If the item has more than one condition, the highest priority code is shown. In order of priority, D is the highest, followed by T and L.

SEQ (User Sequence) (USRSQ). The user-designated sequence number for this component that is used to establish the sequence of the bills of material. This field appears only if the user sequence function was chosen during application tailoring.

COMPONENT (Component Item Number) (CINBR). The item number for the component.

DESC (TRUNC) (Truncated Component Description) (ITD20). An abbreviated description of the component associated with the parent item.

QTY PER (Quantity Per) (QTYPR). The quantity of the component item used to produce the amount of the parent item you specified in the QTY field. This quantity is adjusted by the standard batch quantity.

The following current cost fields are described together for purposes of continuity. These are the default cost element headings. The actual headings depend on the titles entered in the PDM Control file.

PURCHASE
PUR-OVERHEAD
LABOR
LAB OVERHEAD

TOTAL (CDTUC or STDUC). In the upper right part of the display, these fields include the total cost for this parent item assembly as it was calculated in the last costing run and the breakdown of this total into its constituent parts.

In the lower part of the display, these fields include the total cost for the individual component item and the breakdown of this total into its constituent parts (such as Purchase, Purchase Overhead, Labor, and Labor Overhead, for example). The total cost is extended by the quantity used in assembling the parent item.

These fields are calculated by adding the this-level costs (such as Purchase, Purchase Overhead, Labor, Labor Overhead, for example, and Total) to the lower-level costs (such as Purchase, Purchase Overhead, Labor, Labor Overhead, for example, and Total). The following fields appear on the last page of component item data for the item you entered.

COMPONENTS SUB TOTAL. The sub total of the components used in the assembly of the parent item and the breakdown of this total into its constituent parts (such as Material, Purchase Overhead, Labor, and Manufacturing Overhead, for example).

COMPONENTS TOTAL COST. The total cost of all of the components used in the assembly of the parent item and the breakdown of this total into its constituent parts (such as Material, Purchase Overhead, Labor, and Manufacturing Overhead, for example).

THIS LEVEL ITEM COST. The sum of this-level costs required to assemble all of the components into the parent item.

TOTAL ITEM COST. The total cost of the parent item, including all cost elements.

Note: The total item cost should equal the total cost for the parent item (see above). If these two fields are not equal, it is possible that the cost of one of the component items was changed and product costing was not rerun, engineering effectivity dates are causing different components to be used than were originally used for the costing run, there is a fractional quantity per in the product structure, or feature and options cost roll factor (FOPCF) was used. If the two total cost fields are not equal, you should use the PDM inquiries at the component level and also check the cost status and recost flags to find the reason.

AMEC42—Single Level Costed—Standard (Inquiry)

Use this display to review the standard costs associated with this parent item's single level product structure. This display appears when ACTION 2 (Standard Costs) and a valid item number are entered on display AMEC40. This display shows information in the same format as display AMEC41 except it uses standard costs instead of current costs.

The summary cost element titles that appear in this illustration are the XA default headings. The actual titles depend on the titles that were entered in the PDM Control file.

```

DATE **/**/**      SINGLE LEVEL COSTED - STANDARD      INQUIRY  AMEC42  **
EFFECTIVE nnnnnn   QTY nnnnnnnn   PURCHASE*****  *****.*****
ITEM aaaaaaaaaaaaA15      U/M **   PUR-OVERHEAD*   *****.*****
S-NO. aaaaaaaaaaaaA20      LABOR*****     *****.*****
DESC *****.*****      LAB-OVERHEAD*   *****.*****
LAST COSTED **/**/**      TOTAL          *****.*****
SBQ *****.***  ITYPE *    ICLASS ****  RECAST FLAG *  COST STATUS *
SEQ COMPONENT          QTY PER      PURCHASE****  LABOR*****
DESC (TRUNC)  I/T I/C  U/M      PUR-OVERHEAD*  LAB-OVERHEAD*
**** *****.*****  *****.***  *****.*****  *****.*****
OPT ** *****.*****  *  **** **  *****.*****  *****.*****
                                     TOTAL:          *****.*****
**** *****.*****  *****.***  *****.*****  *****.*****
OPT ** *****.*****  *  **** **  *****.*****  *****.*****
                                     TOTAL:          *****.*****
                                COMPONENTS SUB TOTAL *****.*****
                                *****.*****  *****.*****
                                COMPONENTS TOTAL COST: *****.*****
                                THIS LEVEL ITEM COST: *****.*****
                                TOTAL ITEM COST: *****.*****

                                USE ROLL UP
                                F05 CURRENT COSTS
                                F24 END OF JOB
    
```

What to do

- To look at the information for another item, type the item number in the *ITEM* field and any optional information you choose. Press **Enter**. This display appears again with the single-level standard costed bill of material for the new item.
- To see this item's current costs, use **F05**. Go to display AMEC41.

Function keys

USE ROLL UP allows you to scroll forward through a list of options on the display.

F05 CURRENT COSTS causes display AMEC41 to appear.

F24 END OF JOB causes the Inquiry menu (AMEM02) to appear again.

Fields

Except for substituting standard for current costs, the fields on this display are the same as those on display AMEC41. See "AMEC41—Single Level Costed—Current (Inquiry)" for descriptions of the fields on this display.

Option 4. Routing (AMEM02)

Use this option anytime you want to see routing information about an item. This option shows the sequence of operations an item is expected to pass through on the shop floor.

Note: You can see routing information only if both the Routing Master and Production Facility files were selected during application tailoring.

What information you need: The item number for each item whose routing you want to see.

What reports are printed: None.

What forms you need: None.

AMED40—Routing Operations (Select)

Use this display to select the item whose routing you want to see.

This is the first display that appears when you select option 4 on the PDM Inquiry menu (AMEM02) or option 4 on the CRP Inquiry menu (AMTM20).

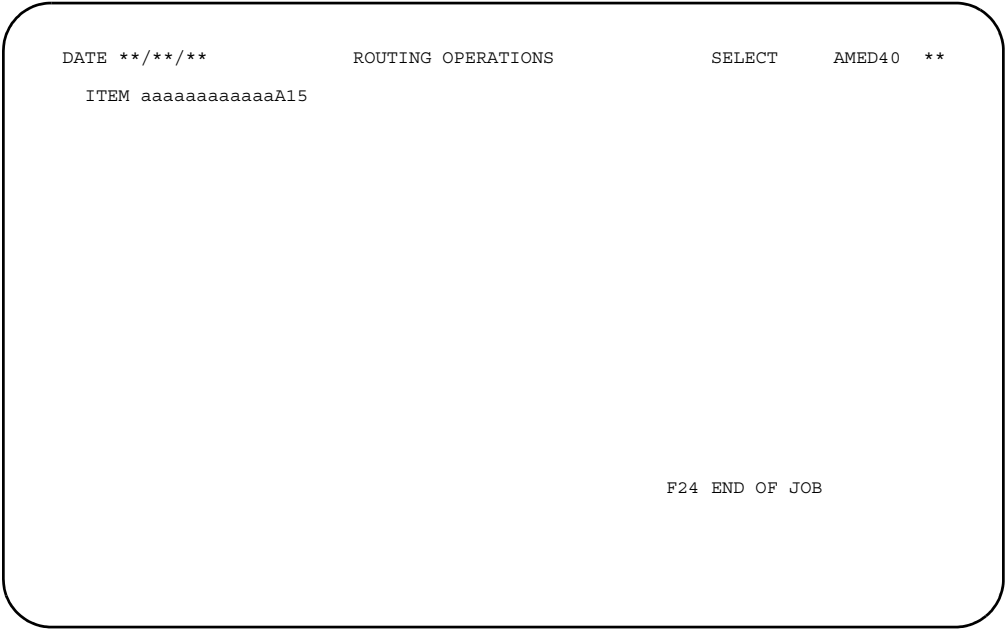

What to do

To inquire about an item's routing operations, type in the item number and press **Enter**.

Function keys

F24 END OF JOB causes the menu to appear again.

Fields

[?] appears next to a field name in the following field definitions to identify a field from which you can begin a master file search.

ITEM (ITNBR) [?]. Required. Type in the number of the item whose routing operations you want to see.

AMED41—Routing Operations (Inquiry)

Use this display to review summarized or detailed routing information for the item number you entered.

This display appears when you type a valid item number on display AMED40.

This display first appears showing a line of summary information for each operation associated with this item. When you use F10, you see detailed information for two operations at a time.

This display shows routing information for the item entered. Detailed information includes operation number, operation description, production facility, time basis code, run times for machine and labor, setup hours and crew size, queue days, move days, and standard and current operation yield.

If you chose to use additional routing operation descriptions, you can enter an operation number on this display. This causes display AMED46 to appear. Display AMED46 shows the additional description information for the chosen routing operation.

```

DATE **/**/**          ROUTING OPERATIONS          INQUIRY    AMED41  **
ITEM aaaaaaaaaaaA15 *****
M          -----RUN-----  ---SETUP---  OP
OPER S  DESCRIPTION          TBC   MACH   LABOR   TIME CREW ST FAC
**** * *****
CURRENT YIELD   * .***   AVG:   *** .**   *** .**   *** .**
STANDARD YIELD * .***   INV TRANS CODE **   TOOL          *****
MOVE DAYS      ** .**   SELECT NUMBER  **   PROCESS        *****
QUEUE DAYS     ** .**   PRINT FLAG    *   TIMES REPT    **
OPER RUN QTY   **** .**   REPORT POINT  *   ADDL DSC CNT  ***

FOR ADDITIONAL DESCRIPTIONS          +
ENTER OPERATION NUMBER aaA4          USE ROLL UP/DOWN
                                       F10 DETAIL/SUMMARY
                                       F24 END OF JOB

```

What to do

- To look at the routing information for another item, type the item number in the **ITEM** field and press **Enter**. This display appears again with the routing information for the new item.
- To look at the additional descriptions for a routing operation, type the operation sequence number in the **ENTER OPERATION NUMBER** field and press **Enter**. Go to display AMED46.
- To see detailed routing information for this item, use **F10**.

Function keys

USE ROLL UP/DOWN allows you to scroll forward and backward through the list on the display.

F10 DETAIL/SUMMARY. If you are viewing detailed information and you use F10, the summary information appears. If you are viewing summary information and you use F10, the detail information appears.

F24 END OF JOB causes the Inquiry menu (AMEM02) to appear again.

Fields

[?] appears next to a field name in the following field definitions to identify a field from which you can begin a master file search.

The ITEM and ENTER OPERATION NUMBER fields are optional. The remaining fields are informational.

ITEM (ITNBR) [?]. When you have completed reviewing the routing operations for the parent item entered, type in the next parent whose routing operations you want to see.

Description (ITDSC). This field appears to the right of the field ITEM and has no heading. It shows the description of the item that normally appears on inquiries, reports, and routings.

OPER (Operation Sequence Number) (OPSEQ). The number defining the sequence in which the operations are listed or shown.

MS (Milestone) (MLSTN). The milestone operation type and identifies an operation that belongs to a milestone group of operations:

- B** The first sub-operation of a milestone group with no activity reported
- S** A sub-operation of a milestone group that is between the first and the last sub-operation
- J** The last sub-operation of a milestone group for a job shop type of milestone group
- F** The last sub-operation of a milestone group for a flow shop type of milestone group

DESCRIPTION (OPDSC). A full description of the operation that normally appears on inquiries, reports, and routings.

TBC (Time Basis Code) (TBCOD). This code is used to develop standard run labor hours, run machine hours, and run labor costs:

- blank** Hours per unit
- C** Cost per piece
- H** Hours per lot
- M** Minutes per piece
- P** Pieces per hour
- 1** Hours per 10 units
- 2** Hours per 100 units
- 3** Hours per 1,000 units
- 4** Hours per 10,000 units.

RUN MACH (Run Machine Time) (RUNMC). When Run Machine Time is extended by the Time Basis Code, this is the time in hours or minutes that the machine in the associated facility is expected to run to produce one or more units (depending on the TBC) of the associated item. If the time basis code is C, which indicates a special usage, the Run Machine Time is not adjusted. PDM product costing can optionally use this field to determine the run machine portion of standard and current labor overhead content this-level in the associated Item Master B-record.

RUN LABOR (Run Labor Time) (RUNLB). This field is not used if the time basis code is C. When Run Labor Time is extended by the Time Basis Code, this field shows the expected hours of run labor necessary to produce one unit of this item. If the time basis code is P, labor represents the quantity per hour. If the cost technique code is R, PDM product costing uses this field to determine the run labor portion of standard and current labor and labor overhead content this-level in the associated Item Master B-record.

SETUP TIME (Setup Labor Time) (SULHR). The labor time in hours or minutes required to set up this operation. PDM product costing can optionally use this field to determine the labor setup portion of standard and current labor and labor overhead content this-level in the associated Item Master B-record.

SETUP CREW (Setup Crew size) (SUCSZ). The number of people in the crew that does the setup of this operation. PDM's product costing can optionally use this field to determine the machine setup portion of standard and current overhead content this-level in the associated Item Master B-record.

OP ST (Operation Status Code) (OPSTC). The operation status code for an operation.

00 Inactive
10 Active.

FAC (Facility ID) (WKCTR). The area where the routing operation is performed.

The following fields appear only when you are viewing detailed information:

CURRENT YIELD (Current Operation Yield) (CYTOP). A percentage that represents today's or the near-term future expected amount of the parent item that remains in the production process at the end of an operation compared to the amount available at the start of the operation. This percentage is used for current costing, scheduling, and material requirements. The default is 1.000 (100%).

AVG RUN MACH (Average Run Machine Time) (AVGRM). The average run machine time is the average of actual run machine time for each active operation for a particular routing, adjusted by the Time Basis Code. This field is updated when order closeout and purge is performed.

AVG RUN LABOR (Average Run Labor Time) (AVGRL). The average run labor time is the average of actual run labor time worked on each active operation for a particular routing, adjusted by the Time Basis Code. This field is updated when order closeout and purge is performed.

AVG SETUP TIME (Average Setup Labor Time) (AVGSL). The average setup labor time. This is the average of actual setup labor time worked on each open operation for a particular routing record. This field is updated when order closeout and purge is performed.

STANDARD YIELD (Standard Operation Yield (SYTOP)). A percentage that represents the budgeted or annual estimate of the amount of the parent item expected to remain in the production process at the end of an operation compared to the amount available at the start of the operation. This percentage is used for standard costing. The default is 1.000 (100%).

INV TRANS CODE. This code tells you the type of transaction for a purchase order routing. The valid codes are:

VA	Vendor acknowledgment
RD	Receipt to dock
RI	Receipt to inspection
RP	Stock receipt
PQ	Purchase quantity control.

TOOL (Tool Number) (RTOOL). The number of the tool or tools needed to perform this operation.

MOVE DAYS (MOVTM). The planned move time, in days, for a manufacturing operation. It is used in the manufacturing order scheduling routines.

SELECT NUMBER. The number used to identify the alternate routing for this operation.

PROCESS (Process Sheet Number) (PRONO). The number used to identify a user document that explains detailed instructions related to this manufacturing operation.

QUEUE DAYS (STDQT). The expected number of days a job waits at this facility before work on it begins.

Note: The above field is contained in the Production Facility file.

PRINT FLAG. This code determines whether this operation appears on certain reports. Valid codes are:

Y	Yes
N	No

TIMES REPT (Times Reported) (NOTIM). The number of times that activity has been reported against this routing operation. This field is updated when order closeout and purge is performed.

OPER RUN QTY (PUNIT). This field tells you the standard quantity for the end item you are processing at this facility.

REPORT POINT (IRCOD). This field tells you if reporting is mandatory for this operation when the item appears on a REP schedule. If the item type is Purchased, this field does not appear. The valid codes are:

0	Reporting is not required.
1	Reporting is required; backflushing occurs.

ADDL DSC CNT (Additional Description Count) (NODES). The number of additional routing description records for the operation. This field appears only if additional routing operation description was selected during application tailoring.

[Contents](#)

[Index](#)

OUTSIDE COST (OSCS). The vendor's per-piece price for the outside operation. This field is used if the time basis code is C.

AVERAGE OUTSIDE COST (AOSC). The vendor's average per-piece price for the outside operation. This field is used if the time basis code is C.

ENTER OPERATION NUMBER (Operation Sequence Number) (OPSEQ). When you want to display the additional descriptions for a routing operation, enter the operation sequence number and the AMED46 display appears. This field appears in the lower left portion of the display only if additional routing operation description was selected during application tailoring.

AMED46—Routing Operation Description (Inquiry)

Use this display to review additional descriptions for the item and operation you entered.

This display appears when you type a valid operation number on display AMED41. An operation number can only be entered on display AMED41 if the additional routing description function was chosen during application tailoring.

This display appears only if you requested the additional description information for a routing operation. The detailed information on this display includes the facility, a count of existing description records, and a list of the first additional descriptions.

```
DATE **/**/**      ROUTING OPERATION DESCRIPTION          INQUIRY      AMED46 **
ITEM      aaaaaaaaaaA15  OPER SEQ aaA4     FACILITY ID *****
OPERATION DESCRIPTION ***** ADDL DESC COUNT ***

LINE      ADDITIONAL DESCRIPTION
***      *****
***      *****
***      *****
***      *****
***      *****
***      *****
***      *****
***      *****
***      *****
***      *****
***      *****
***      *****
***      *****
***      *****
***      *****
***      *****
***      *****
***      *****
***      *****

                                         +
                                         USE ROLL UP/DOWN
                                         F03  PREV SCREEN
                                         F24  END OF JOB
```

What to do

To look at the routing operation description for another item, type in the new item number and press **Enter**.

Function keys

USE ROLL UP/DOWN allows you to scroll forward and backward through the list on the display.

F03 PREV SCREEN causes display AMED41 to appear again.

F24 END OF JOB causes the Inquiry menu (AMEM02) to appear again.

Fields

[?] appears next to a field name in the following field definitions to identify a field from which you can begin a master file search.

Two fields on this display, ITEM and OPER SEQ, are optional. The remaining fields on this display are informational only.

ITEM (Item Number) (ITNBR) [?]. When you have completed reviewing the additional descriptions for the routing operation you selected, type in the next item whose additional operation descriptions you want to see. You can also type in a new operation sequence number.

OPER SEQ (Operation Sequence Number) (OPSEQ). Type in the operation sequence number of the next operation whose additional descriptions you want to see.

FACILITY ID (Facility ID) (WKCTR). This field identifies the area where the routing operation is performed.

OPERATION DESCRIPTION (OPDSC). A short description of the task performed during this operation.

ADDL DESC COUNT (Additional Description Count) (NODES). The number of additional routing description records for the operation.

LINE (Description Line Number) (DSQNO). The line number of the routing operation's additional description.

ADDITIONAL DESCRIPTION (ADDSC). The additional descriptive information for a routing operation.

Option 5. Production Facility (AMEM02)

Use this option anytime you want to see information from the Production Facility file about facilities.

Notes:

1. You can see production facility information when you selected the Production Facility file during application tailoring.
2. You can see variable capacity information using display AMVD62 when Repetitive Production Management or Capacity Requirements Planning is installed and interfacing.
3. You can see information about production line and work station facilities when Repetitive Production Management is installed and interfacing.

What information you need: The identifier (ID) for each facility you want to see.

What reports are printed: None.

What forms you need: None.

AMVD60—Production Facility Inquiry (Select)

Use this display to select a facility record for review.

This is the first display that appears when you select option 5 from the PDM Inquiry menu (AMEM02) or option 6 from the REP Inquiry menu (AMQM10), if EPDM is not activated. It also appears when you select option 5 from the CRP Planning Run Control menu (AMTM10), option 4 from the PC&C Inquiry menu (AMCM10) or option 3 from the PM&C Inquiry menu (AMJM10), if EPDM is not activated.

```
DATE **/**/**          PRODUCTION FACILITY INQUIRY          SELECT          AMVD60  **
FACILITY ID          aaaA5

F24 END OF JOB
```

What to do

To inquire about production facilities defined in the Production Facility file, type in a facility ID and press **Enter**. Go to display AMVD62.

Function keys

F24 END OF JOB ignores the data you just entered and causes the menu to appear again.

Fields

[?] appears next to a field name in the following field definitions to identify a field from which you can begin a master file search.

FACILITY ID (WKCTR) [?]. Required. Type in the unique identification representing the facility being reviewed.

AMVD61—Production Facility Inquiry

Use this display to review detailed information for the facility identified on display AMVD60.

This display appears when you type a valid ID on display AMVD60.

Examples of information shown on the display include facility type, foreman, location, standard and average efficiency, queue time, standard and actual average output, current and standard rates, lengths and capacities for three shifts, and machine and labor resource numbers.

```

DATE **/**/**          PRODUCTION FACILITY INQUIRY          AMVD61  **
FACILITY ID          aaaA5          FACILITY TYPE *          *****
DESCRIPTION          *****
DEPARTMENT          ****          PN FAC ACTG CLS          ***          QUEUE TIME DAYS          **.*
FOREMAN             ***          PRIME LOAD CODE          *          AVG QUEUE TIME          *****
LOCATION             *****          TRACKING SIGNAL          *****          QUEUE MAD          *****
STD EFFICIENCY      *.*          AVG STD OUTPUT          *****          MACH RESOURCE NO.          *****
AVG EFFICIENCY      *.*          AVG ACTL OUTPUT          *****          LABOR RESOURCE NO.          *****
EXTRACT MACH BRKS  *          REPORTING METHOD          *          CLOCKING WINDOW          *:*

          MACHINE          RUN LABOR          SETUP LABOR          OVERHEAD          OVERHEAD
          RATE           RATE           RATE           RATE/PERCENT       CODE
CURRENT          **,*.*.*          **,*.*.*          **,*.*.*          **,*.*.*          *
STANDARD          **,*.*.*          **,*.*.*          **,*.*.*          **,*.*.*          *

          -----LENGTH-----          -----CAPACITY-----          DIRECT USAGES          *
          DESIRED  MAXIMUM          DESIRED  MAXIMUM          CALENDAR NAME          *****
SHIFT 1          *.*          *.*          *.*          *.*          POST TO OLDEST SCHED          *
SHIFT 2          *.*          *.*          *.*          *.*          POST TO FUTURE SCHED          *
SHIFT 3          *.*          *.*          *.*          *.*          FACILITY STOCK LOC          *****
**

          F02 VARIABLE CAPACITY
          F24 END OF JOB
    
```

What to do

- To look at variable capacity information for this facility, use **F02**. Go to display AMVD62.
- Note:** If REP and/or CRP are not installed and interfacing, **F02** does not appear on the display.
- To look at another production facility record, type in the facility ID and press **Enter**. This display appears again with information for that production facility.

Function keys

F02 VARIABLE CAPACITY. If REP or CRP is interfacing, the Production Facility Inquiry–Variable Capacity display (AMVD62) appears with variable capacity information for this facility.

F24 END OF JOB causes the menu to appear again.

Fields

[?] appears next to a field name in the following field definitions to identify a field from which you can begin a master file search.

FACILITY ID (WKCTR) [?]. Required. When you have completed reviewing the detail for this facility, you can type in the ID of the next facility you want to see.

FACILITY TYPE. This field has no heading and appears to the immediate right of **FACILITY ID**. It shows the type of facility this is, such as WORK CENTER, WORK STATION, or PRODUCTION LINE.

DESCRIPTION (WCDSC). The name of the facility.

DEPARTMENT (DPTNO). The department number associated with the facility.

PN FAC ACTG CLS (PFAC). Class, defined by your company, to group or classify orders or items by production facility for accounting purposes.

QUEUE TIME DAYS (STDQT). The expected number of days a job may wait at the facility before being started.

FOREMAN (FRMAN). A three-character code that identifies the facility foreman.

PRIME LOAD CODE (PLOAD). The critical operation time factor used in scheduling routines.

AVG QUEUE TIME (AVGQT). The average total standard hours of work in the queue at this facility.

LOCATION (WCLOC). The facility location.

TRACKING SIGNAL (TRSIG). The sum of the deviation of the current queue from the old average queue.

QUEUE MAD (Queue Mean Absolution Deviation) (WQMAD). The Queue Mean Absolute Deviation—an average of the differences between the current queue and the old average queue.

STD EFFICIENCY (Standard Efficiency) (STDEF). This field shows the expected efficiency of the facility. The percentage is manually maintained and reflects the expected value of standard average output divided by average actual output.

AVG STD OUTPUT (Average Standard Output) (AVGSO). The expected average of the standard time (hours) produced per day for this period (PC&C order closeout) at the facility.

MACH RESOURCE NO. (Machine Resource Number) (MACRN). The resource number used by MPSP (if installed and interfacing) to identify machine hours in a facility as a critical resource. For example, a machine that affects major work flow in a facility.

AVG EFFICIENCY (Average Efficiency) (AVGEF). The average of the standard output per day for this period divided by actual hours worked per day for this period.

AVG ACTL OUTPUT (Average Actual Output) (AVGHO). The average of the hours actually worked per day for this period (PC&C order closeout) at the facility.

LABOR RESOURCE NO. (LABRN). The resource number used by MPSP (if installed and interfacing) to identify labor hours in a facility as a critical resource. For

example, it may show a facility with limited available labor hours because of workers with special skills.

EXTRACT MACH BRKS (BRKXT) <1/0>. Indicates whether PM&C is extracting break time from machine hours. This field appears only if PM&C is interfacing.

REPORTING METHOD. The method used at the facility for reporting job transactions in PM&C. The values for the methods are:

- 0** ON/OF reporting. Both ON (On) and OF (Off) transactions are required for each job. Jobs completed without both transactions are flagged as errors.
- 1** Off-only reporting with full ON override. OF transactions are required for each job. ON transactions are optional. If a job starts with an ON transaction, all information is used from the ON transaction. If an ON transaction does not exist, start times for the job are calculated from previous OF and T/A transactions and all other information is used from the OF transaction.
- 2** Off-only reporting with ON facility ID override. OF transactions are required for each job. ON transactions are optional. If the job starts with an ON transaction, the only information used from the ON transaction is the facility ID. All other information is used from the OF transaction. Start times are always calculated from previous OF and T/A transactions (even if an ON transaction exists).

CLOCKING WINDOW. The clocking window time defined in PM&C for facilities using off-only reporting to group jobs that are run concurrently by the same employee and apportion time among those jobs. It can be any value from 0:00 to 9:59 (one second less than ten minutes). A value of 0:00 indicates that jobs at this facility are treated as if they are done consecutively.

This field is used by the Production Monitoring and Control (PM&C) application.

CURRENT MACHINE RATE (CMACH). This rate, expressed in cost per hour, is used only by PDM product costing with the run machine field of the associated routing to calculate current run machine cost.

CURRENT RUN LABOR RATE (CRLAB). This rate, expressed in cost per hour, is used only by PDM product costing with the run labor field of the associated routing to calculate current run labor cost.

CURRENT SETUP LABOR RATE (CSLAB). This rate, expressed in cost per hour, is used only by PDM product costing with the setup labor hours field of the associated routing to calculate current setup labor costs.

CURRENT OVERHEAD RATE/PERCENT (COVER). This value, expressed in cost per hour or percent depending on the current labor overhead code, is used only by PDM product costing in labor overhead calculation.

CURRENT OVERHEAD CODE (COCOD). This code indicates which of four methods is used only by PDM product costing to calculate current labor overhead.

STANDARD MACHINE RATE (SMACH). This rate, expressed in cost per hour, is used by PC&C order costing and PDM product costing with the run machine field of the associated operation detail and routing to calculate standard run machine cost.

STANDARD RUN LABOR RATE (SRLAB). This rate, expressed in cost per hour, is used by PC&C order costing and PDM product costing with the run labor field of the associated operation detail and routing to calculate standard run labor cost.

STANDARD SETUP LABOR RATE (SSLAB). This rate, expressed in cost per hour, is used by PC&C order costing and PDM product costing with the setup labor time field and setup crew size of the associated operation detail and routing to calculate standard setup labor cost.

STANDARD OVERHEAD RATE/PERCENT (SOVER). This value, expressed in cost per hour or percent according to the standard labor overhead code, is used in labor overhead calculation by PC&C order costing and PDM product costing.

STANDARD OVERHEAD CODE (SOCOD). This code indicates which of four methods is used to calculate standard labor overhead.

DESIRED LENGTH (DLEN1, DLEN2, DLEN3). The number of prime load code hours normally available for the duration of shifts 1, 2, and 3 for this facility.

MAXIMUM LENGTH (MLEN1, MLEN2, MLEN3). The maximum number of prime load code hours available for this facility that can be scheduled for shifts 1, 2, and 3.

DESIRED CAPACITY (DCAP1, DCAP2, DCAP3). The number of employees or machines normally available in this facility for shifts 1, 2, and 3.

MAXIMUM CAPACITY (MCAP1, MCAP2, MCAP3). The maximum number of employees or machines available for shifts 1, 2, and 3.

DIRECT USAGES (NORWU). The number of routing records in which the facility appears.

CALENDAR NAME (CALN). The name of the production calendar associated with this facility. This calendar is used only by REP to explicitly define the days a production line is available for work.

POST TO OLDEST SCHED (APSQ). The method used for applying transaction quantities to REP schedules. The valid codes are:

blank Defaults to the setting from the REPCTL record.

0 Off, posting is by individual schedules for all items on this production line.

1 On, multi-schedule posting, beginning with the oldest schedule, is used for all items on this production line.

POST TO FUTURE SCHED (APTQ). The method used for applying transaction quantities to REP schedules. The valid codes are:

blank Defaults to the setting from the REPCTL record.

0 Off, post to past and current schedules on this production line.

1 On, post to past, current, and future schedules on this production line.

FACILITY STOCK LOC (FSLC). If the facility is a workstation, this field represents the line location where items are delivered and used in a production line operation. If the facility is a production line, then this field represents the stocking location where finished goods are stored. This field is used by REP as a default line location when setting up the Item-Line definition for a schedule controlled item.

AMVD62—Production Facility Inquiry—Variable Capacity

Use this display to review detailed variable capacity information for the facility identified on display AMVD61. Variable capacity information can apply only to work centers or production lines (facility types 1 and 2).

This display appears only if REP or CRP is installed.

Information on the display includes resource availability date and duration, shift length and resource unit information for three shifts, and a description of the resource.

```

DATE **/**/**          PRODUCTION FACILITY INQUIRY          AMVD62 **
                        VARIABLE CAPACITY

FACILITY ID          *****
DESCRIPTION          *****

   START   NBR   -SHIFT LENGTH-   -RESOURCE UNITS-
   DATE   DAYS    1     2     3     1     2     3   SOURCE DESCRIPTION
**/**/** ** **.* **.* **.* **.* **.* **.* **.* **.* **.*
**/**/** ** **.* **.* **.* **.* **.* **.* **.* *****
**/**/** ** **.* **.* **.* **.* **.* **.* **.* *****
**/**/** ** **.* **.* **.* **.* **.* **.* **.* *****
**/**/** ** **.* **.* **.* **.* **.* **.* **.* *****
**/**/** ** **.* **.* **.* **.* **.* **.* **.* *****
**/**/** ** **.* **.* **.* **.* **.* **.* **.* *****
**/**/** ** **.* **.* **.* **.* **.* **.* **.* *****
**/**/** ** **.* **.* **.* **.* **.* **.* **.* *****
**/**/** ** **.* **.* **.* **.* **.* **.* **.* *****
**/**/** ** **.* **.* **.* **.* **.* **.* **.* *****
**/**/** ** **.* **.* **.* **.* **.* **.* **.* *****
**/**/** ** **.* **.* **.* **.* **.* **.* **.* *****
**/**/** ** **.* **.* **.* **.* **.* **.* **.* *****
**/**/** ** **.* **.* **.* **.* **.* **.* **.* ***** +

                                         USE ROLL UP/DOWN
                                         F03 PREVIOUS SCREEN
                                         F24 END OF JOB
    
```

What to do

To look at another record, use **F03**. Go to display AMVD61.

Function keys

USE ROLL UP/DOWN allows you to scroll forward and backward through the list on the display.

F03 PREVIOUS SCREEN causes the Production Facility Inquiry display (AMVD61) to appear.

F24 END OF JOB causes the menu to appear again.

Fields

FACILITY ID (WKCTR). The identifier for the facility. When you have finished reviewing the detail for this facility or production line, you can type in the ID of the next facility you want to see.

FACILITY TYPE. This field shows the kind of production facility that is associated with the facility ID: work center, production line, or work station.

Note: A work station cannot have variable capacity information associated with it.

DESCRIPTION (WCDSC). A description of this facility.

START DATE (VDATE). The date this variable resource becomes available.

NBR DAYS (VDAYS). The duration for which the variable resource is available. If the value is 99, this is a permanent resource.

SHIFT LENGTH 1, 2, and 3 (VLEN1, VLEN2, VLEN3). The available time in hours of each shift for a particular work center or production line. The variable dates for each shift cannot overlap.

RESOURCE UNITS 1, 2, and 3 (VCAP1, VCAP2, VCAP3). The number of extra units above base capacity for this resource. Resource units are expressed in shift length increments such that each resource unit works the entire shift time. For example, if the shift length is 8 hours and you want to add one unit of 4 hours, you type **5** as the resource units to indicate that this resource should work half of the shift length.

SOURCE DESCRIPTION (VDESC). The reason for the change to the variable capacity. Examples are Scheduled Overtime or Lead Operator on Vacation.

Option 6. Feature/Options (AMEM02)

Use this option anytime you want to see information about the features and options associated with an end-item.

Note: You can see features and options information only if features and options were selected during application tailoring.

What information you need: The item number for each end-item whose features and options you want to see.

What reports are printed: None.

What forms you need: None.

AMED80—Feature/Options (Select)

Use this display to select the end-item whose features and options you want to see.

This display appears when you select option 6 on the Inquiry menu (AMEM02).

```
DATE **/**/**          FEATURE/OPTIONS          SELECT          AMED80 **
END-ITEM aaaaaaaaaaaaA15

F24 END OF JOB
```

What to do

To inquire about an end-item's features and options, type in the end-item number and press **Enter**.

Function keys

F24 END OF JOB causes the Inquiry menu (AMEM02) to appear again.

Fields

[?] appears next to a field name in the following field definitions to identify a field from which you can begin a master file search.

END-ITEM (ITNBR) [?]. Required. Type in the number of the end-item whose features and options you want to see.

AMED81—Feature/Options (Inquiry)

Use this display to review all the options for all the features available for the end-item you entered.

This display appears when you type a valid number of an end-item having features entered on display AMED80.

This display shows all the options for all the features available for the end-item entered. It shows item description, cost roll-up factor, planning factor, feature or option number, and if the feature is required.

```
DATE **/**/**          FEATURE/OPTIONS          INQUIRY  AMED81 **
                      *****                S-NO.  TEMPLATE NO. 1
                      *****                *****
S-NO.  F/O  ITEM          STD  BATCH QTY  ** , *** , *** . ***          COST
POS   F/O  ITEM          DESCRIPTION-TRUNCATED        QUANTITY        ROLL  PLANNING
***** **  *****          *****                *****        FACTOR FACTOR
**   **  *****          *****                *****        * . **** * . ****
**   **  *****          *****                *****        * . **** * . ****
**   **  *****          *****                *****        * . **** * . ****
**   **  *****          *****                *****        * . **** * . ****
**   **  *****          *****                *****        * . **** * . ****
**   **  *****          *****                *****        * . **** * . ****
**   **  *****          *****                *****        * . **** * . ****
***** **  *****          *****                *****        *****
*   *   *****          *****                *****        * . **** * . ****
*   *   *****          *****                *****        * . **** * . ****
*   *   *****          *****                *****        * . **** * . ****
*   *   *****          *****                *****        * . **** * . ****
*   *   *****          *****                *****        * . **** * . ****
*   *   *****          *****                *****        * . **** * . ****

                               USE ROLL UP/DOWN
                               F24 END OF JOB
                                      +
```

What to do

To look at the features and options for another end-item, type the item number in the **END-ITEM** field and press **Enter**.

Function keys

USE ROLL UP/DOWN allows you to scroll up and down through the list of options on the display.

F24 END OF JOB causes the menu to appear again.

Fields

[?] appears next to a field name in the following field definitions to identify a field from which you can begin a master file search.

One field on this display, END-ITEM, is optional. The remaining fields are informational only.

The words REQUIRED or NON-REQD appear following each feature's description.

END-ITEM (ITNBR) [?]. When you have finished reviewing the features and options for this end-item, you can enter the number of the next end-item for inquiry.

Description (ITDSC). This field appears to the right of the field END-ITEM and has no heading. It shows the description of the end-item that normally appears on invoices, inquiries, and reports.

S-NO. TEMPLATE NO. (FOTAB). Use this field as a template to specify the option and features you want. You will see an array of 20 elements, one position each. Each element can contain only 0, 1, or 2 for the maximum field size of each feature's option number. The array can be considered as a template that is laid over an S-number to locate the option selected for its respective feature. The template or array is set up in the PDM Questionnaire only when feature/options have been selected.

Note: This field is located in the SYSCTL file record type EF.

STD BATCH QTY (Standard Batch Quantity) (SBQTY). The quantity of the parent item relative to the quantity of each component item. The product structure (recipe or formulation) is expressed as a batch quantity of the parent item as opposed to a quantity of one stocking unit.

S-NO. POS (S-number Position). The values in this field describe the relative position within the S-NUMBER TEMPLATE NO. field of each feature. For example, an item might have only two features. Feature 1 (with up to 35 options) would be located in position 01—01, while feature 02 (with up to 1295 options) would be located in positions 02—03. The first three numbers in the S-NUMBER TEMPLATE NO. field would then be 1 and 02, and the entire template (FOTAB) would appear as 10200000000000000000.

F/O (Feature/Option Number) (FOPNO). This field shows a numbered list (user assigned) of the end-item's features and options of those features.

ITEM (ITNBR). This field shows the number (user assigned) used to uniquely identify each feature and its respective options.

DESCRIPTION-TRUNCATED (ITD20). This field shows the abbreviated description of this component (option).

QUANTITY (Quantity Per). This field shows the quantity of the component item used in the production of a standard batch quantity of the parent item.

COST ROLL FACTOR (Feature/Options Cost Roll-Up Factor) (FOPCF). This field indicates to PDM product costing what portion of the component (option) is to be rolled up into the parent's (feature's) cost fields. This field is used only if you answered YES to the product costing question in the PDM Questionnaire.

PLANNING FACTOR (Feature/Options Planning Factor) (FOPPF). This field indicates to MRP's planning run the average portion of the finished item built with this option.

Option 7. Feature/Options with S-Number Build (AMEM02)

Use this option anytime you want to build an S-number for an end-item.

Note: You can build an S-number only if features and options were selected during application tailoring.

What information you need: The item number for each end-item for which you want to build an S-number.

What reports are printed: None.

What forms you need: None.

AMVD90—Feature/Options with S-Number Build (Select)

Use this display to select the end-item for which you want to build an S-Number.

This display appears when you select option 7 on the Inquiry menu (AMEM02).

```
DATE **/**/**          FEATURE/OPTIONS WITH S-NUMBER BUILD  SELECT      AMVD90 **
END-ITEM aaaaaaaaaaaaA15

F24 END OF JOB
```

What to do

To build an S-number for an end-item, type in the end-item number and press **Enter**. Go to display AMVD91.

You can build an S-number only if features and options were selected during application tailoring.

Function keys

F24 END OF JOB causes the Inquiry menu (AMEM02) to appear again.

Fields

[?] appears next to a field name in the following field definitions to identify a field from which you can begin a master file search.

END-ITEM (ITNBR) [?]. Required. Type in the number of the end-item for which you want to build an S-number.

Function keys

USE ROLL UP/DOWN allows you to scroll up and down through the list of options on the display.

F02 NEXT FEATURE causes the next feature and its options to be displayed. If all the features of this end-item have been displayed or this is a required feature, this function key is not available.

F10 REFRESH S-NO clears the S-number field so you can reselect the options for this end-item.

F24 END OF JOB causes the menu to appear again.

Fields

[?] appears next to a field name in the following field definitions to identify a field from which you can begin a master file search.

Two fields on this display, END-ITEM and OPTION NO. are optional. The remaining fields are informational only.

END-ITEM (ITNBR) [?]. When you have completed building the S-number using the features and options for this end-item, type in the number of the next end-item whose features and options you want to use in building the next S-number.

Description (ITDSC). This field appears to the right of the field END-ITEM and has no heading. It shows the description of the end-item that normally appears on invoices, inquiries, and reports.

S-NO. TEMPLATE NO. 1 (FOTAB). Use this field as a template to specify the option and features you want. You will see an array of 20 elements, one position each. Each element can contain only 0, 1, or 2 for the maximum field size of each feature's option number. The template or array is set up in the PDM Questionnaire only when feature/options have been selected.

OPTION NO (FOPNO). Type in the number of the option you want for the displayed feature and press Enter.

S-NO. Use this field to specify which options and features you want. Type in an array of up to 20 characters containing option numbers for known features.

STD BATCH QTY (Standard Batch Quantity) (SBQTY). The quantity of the parent item relative to the quantity of each component item. The product structure (recipe or formulation) is expressed as a batch quantity of the parent item as opposed to a quantity of one stocking unit.

S-NO. POS (S-number Position). The values in this field describe the relative position within the S-NUMBER TEMPLATE NO. field of each feature. For example, an item might have only two features. Feature 1 (with up to 35 options) would be located in position 01—01, while feature 02 (with up to 1295 options) would be located in positions 02—03. The first three numbers in the S-NUMBER TEMPLATE NO. field would then be 1 and 02, and the entire template (FOTAB) would appear as 10200000000000000000.

[Contents](#)

[Index](#)

F/O (Feature/Option Number) (FOPNO). A numbered list (user assigned) of the end-item's features and options of those features.

ITEM (ITNBR). The number (user assigned) used to uniquely identify each feature and its respective options.

DESCRIPTION-TRUNCATED (ITD20). The abbreviated description of this component (option).

QUANTITY (Quantity Per). The quantity of the component item used in the production of a standard batch quantity of the parent item.

FROM/TO (EDATM, EDATO). The range of dates within which this component is expected to be used to assemble its parent item.

Option 8. Item Foreign Language Descriptions (AMEM02)

Use this option anytime you want to see information about the foreign language descriptions associated with an item.

What information you need: The item number for each item for which you want to see information on foreign language descriptions.

What reports are printed: None.

What forms you need: None.

The displays you use for item foreign language inquiry are the same displays used for file maintenance. See Chapter 6. .

Chapter 4. Reports

When you select option 2 on the Main Menu (AMEM00) the Reports menu (AMEM03) appears. This menu allows you to establish limits and print reports about items, facilities, features and options, product structures, and foreign language descriptions.

Option 1. Item Master Selections (AMEM03)	4-3
Option 2. Production Facility Report–by Facility (AMEM03).....	4-6
Option 3. Production Facility Report–by Department (AMEM03)	4-7
Option 4. Feature/Options Report (AMEM03)	4-8
Option 5. Retrieval Selections–Regular (AMEM03)	4-9
Option 6. Retrieval Selection – Costed (AMEM03)	4-20
Option 7. WIP Cost Worksheet (AMEM03)	4-25
Option 8. Item Foreign Language Description (AMEM03).....	4-28

If you did not choose the Production Facility file, Feature/Options, and Product Costing during application tailoring, and you select options 2, 3, 4, 6, or 7, your request is canceled, and the Main Menu appears again.

Options 1, 5, 6, 7, or 8 cause displays on which you can select report options to appear. Selecting options 2, 3, or 4 causes the Reports menu (AMEM03) to appear again.

```

AMEM03                               Product Data Management          *****
                                      Reports
Type option or command; press Enter.

1. Item Master Selections
2. Production Facility Report - by Facility
3. Production Facility Report - by Department
4. Feature/Options Report
5. Retrieval Selections - Regular
6. Retrieval Selections - Costed
7. WIP Cost Worksheet
8. Item Foreign Language Descriptions

==> _____

F3=Exit      F4=Prompt    F9=Retrieve   F10=Actions
F11=Job status  F12=Return   F22=Messages
    
```

Option 1. Item Master Selections. Use this option to select reports listing some or all item numbers in six (6) possible formats, sequenced by item, vendor, item type, item class, buyer, or item accounting class.

Option 2. Production Facility Report - by Facility. Use this option to print a report showing all facility records by facility ID.

Option 3. Production Facility Report - by Department. Use this option to print a report showing all facility records by facility within department.

Option 4. Feature/Options Report. Use this option to print a report listing all end-items with features, and all of those features.

Option 5. Retrieval Selections - Regular. Use this option to select many variations of product structure and routing retrieval reports.

Option 6. Retrieval Selections - Costed. Use this option to select many variations of costed item, some costed product structure retrieval, and some costed operations cost reports.

Option 7. WIP Cost Worksheet. Use this option to print a Work-in-Process Cost Worksheet for some or all items using standard, current, or average costs. This report shows the value of the unit parent item at the end of each operation step.

Option 8. Item Foreign Language Descriptions. Use this option to print either the item foreign language reports showing either items with or without foreign language descriptions.

After you select the report and the print options, PDM submits the request to the job queue for the report to be printed in batch mode.

The information printed for items (Item Master file) and production facilities (Production Facility file) is the most current information available. However, be aware that changes to bills of material (Product Structure file) and routings (Routing file) may be pending. For example, a new routing or a replaced component may have been entered but not processed yet to update the files and therefore, does not appear on the reports.

Option 1. Item Master Selections (AMEM03)

Use this option anytime you want to see a listing of some or all of the items in the Item Master file.

What information you need:

- The format of the listing you want:
 - Brief format provides one line of information per item.
 - Complete format provides several lines of information per item.
 - Current or Standard Costs format provides two lines of current or standard costing information per item. Current or Standard Costs formats are available only if you selected PDM Costing during application tailoring.
 - Purchase Item Detail format provides detailed purchasing information about items that have such information associated with them.
 - Purchase Item Descriptions format provides a simple listing of items that have purchasing information associated with them.
- The printing sequence of the listing you want:
 - By item
 - By vendor
 - By item type
 - By item accounting class
 - By buyer.
- If you are not printing all of the records within each of the categories above, you should have the beginning and ending number of the category you want printed.

What reports are printed:

- Item Master File Report—Brief (AMVE40)
- Item Master File Report—Complete (AMVE41)
- Item Master File Report—Current or Standard Costs (AMVE42)
- Item Master File Report—Purchase Item Detail (AMEV43)
- Item Master File Report—Purchase Item Description (AMVE44).

What forms you need: None.

AMVE11—Item Master Report (Select)

Use this display to select the run sequence, format, and limits for printing the Item Master report.

This display appears when you select option 1 (Item Master Selections) on the Reports menu (AMEM03).

This display allows you to select the run sequence, report format, and limits. You can print this report sequenced by item, item within vendor, item within item type, or item within item class. You can select BRIEF for one line per item with a portion of the item data, or you can select COMPLETE for all important data per item, which yields only a few items per page. You also can choose to print a short format with current or standard costs. Then, within the run sequence, you can choose to print a subset of the entire Item Master File report. For example, you can choose to include a group of items.

```

DATE **/**/**          ITEM MASTER REPORT          SELECT    AMVE11  **
                                ENTER--
                                RUN SEQUENCE      A
                                REPORT FORMAT      A

RUN SEQUENCE BY          LOWER LIMIT    UPPER LIMIT    VALID FOR
1 SINGLE ITEM           aaaaaaaaaaaaA15  aaaaaaaaaaaaA15  ALL
2 RANGE OF ITEMS       aaaaaaaaaaaaA15  aaaaaaaaaaaaA15  ALL
3 VENDOR                aaaaA6          aaaaA6          (1-4)
4 ITEM TYPE             A               A               (1-4)
5 ITEM CLASS            aaA4            aaA4            (1-4)
6 BUYER                 aaaA5           aaaA5           (5-6)
7 ITEM ACCOUNTING CLASS aaA3            aA3             (1-4)
REPORT FORMAT
1 BRIEF                 5 PURCHASE ITEM DETAIL
2 COMPLETE              6 PURCHASE ITEM DESCRIPTIONS
3 CURRENT COSTS ONLY
4 STANDARD COSTS ONLY

NOTE: IF NO LIMITS ARE ENTERED, ALL ITEMS WILL BE PRINTED (EXCEPT FOR RUN
      SEQUENCE = 1)

                                F24 CANCEL THE JOB

```

What to do

To print the selected Item Master listing, type in the requested information and press **Enter**. The report is scheduled for printing. Go back to the menu.

Function keys

F24 CANCEL THE JOB cancels the job and causes the menu to appear again.

Fields

[?] appears next to a field name in the following field definitions to identify a field from which you can begin a master file search.

RUN SEQUENCE BY. Required. You can select the report run sequence by typing in one of the following numbers:

- 1 Single item. This is the default.
- 2 Range of items
- 3 Vendor
- 4 Item type
- 5 Item class
- 6 Buyer
- 7 Item accounting class.

Depending on the number selected, a report can be printed in a sequence by item, by item within vendor, by item within item type, by item within item class, by item within buyer, or by item within item accounting class.

REPORT FORMAT. Required. You can select the format of the report by typing in one of the following numbers:

- 1 Brief. One line of information per item.
- 2 Complete. Multiple lines of detail per item.
- 3 Current costs only. Two lines of current cost information per item. Available only if Product Costing is active. Not available if you do not have the required security level for working with certain Item Master cost fields.
- 4 Standard costs only. Two lines of standard cost information per item. Available only if Product Costing is active. Not available if you do not have the required security level for working with certain Item Master cost fields.
- 5 Purchase item detail. One line of information per item.
- 6 Purchase item descriptions. Multiple lines of detail per item.

LOWER LIMIT

UPPER LIMIT [?]. You can specify none, one, or all of the values for the run sequence you choose. This allows you to tailor the report to your requirements. For example, you can choose to see a group of items by entering the beginning and ending item numbers. If you specify only a lower limit, all items from that limit on are printed. If you specify only an upper limit, all items up to and including that limit are printed.

Note: If you select run sequence option 2, a range of items, and leave the **ITEM LOWER LIMIT** and **UPPER LIMIT** fields blank, you are asking for all items to be included on the report. This will create a very long report. Be sure this is what you want before you leave the **ITEM** fields blank.

Option 2. Production Facility Report–by Facility (AMEM03)

Use this option anytime you want to print the Production Facility Report sequenced by facility ID.

Note: You can print this report only if the Production Facility file was selected during application tailoring.

What information you need: None.

What reports are printed: Production Facility Report–Sequenced by Facility (AMV43).

What forms you need: None.

No secondary menu or display appears for option 2 on the Reports menu (AMEM03). When you select option 2 and press **Enter**, PDM submits the request to the job queue for the report to be printed in batch mode.

Option 3. Production Facility Report–by Department (AMEM03)

Use this option anytime you want to print the Production Facility Report sequenced by facility ID within each department.

Note: You can print this report only if the Production Facility file was selected during application tailoring.

What information you need: None.

What reports are printed: Production Facility Report Sequenced by Department (AMV43).

What forms you need: None.

No secondary menu or display appears for option 3 on the Reports menu (AMEM03). When you select option 3 and press **Enter**, PDM submits the request to the job queue for the report to be printed in batch mode.

Option 4. Feature/Options Report (AMEM03)

Use this option anytime you want to print the Feature/Options Report.

Note: You can print this report only if features and options were selected during application tailoring.

What information you need: None.

What reports are printed: Feature/Options Report (AMEF1).

What forms you need: None.

No secondary menu or display appears for option 4 on the Reports menu (AMEM03). When you select option 4 and press **Enter**, PDM submits the request to the job queue for the report to be printed in batch mode.

This report is a listing of end items only. All end item features and all of the feature's options are included within the report.

Option 5. Retrieval Selections–Regular (AMEM03)

Use this option anytime you want to print one of the retrieval reports.

What information you need: None.

What reports are printed: One of the following reports is printed depending upon the option you choose on one of the Retrieval Selections (Select) displays:

- Single Level Bill with Blow-Through (AMEF71)
- Indented Bill (AMEF72)
- Summarized Bill (AMEF73)
- Single Level Where-Used (AMEF74)
- End-Item Where-Used (AMEF75)
- Routing List (AMEG11)
- Production Facility Where-Used (AMEG12)
- Routing and Single Level Retrieval with Blow-Through (AMEG4).

What forms you need: None.

AMEF41—Retrieval Selections—Regular—Single List (Select)

Use this display to select the limits for printing the Single List Retrieval reports.

This display appears when you select option 5 (Retrieval Selections—Regular) on the Reports menu (AMEM03) and if both feature/options and the Routing file were selected during application tailoring.

This display allows you to select run options which include: single level bill with blow-through, indented bill, summarized bill, single level where-used, end item where-used, routing, facility where-used, and routing and single level with blow-through. Or, instead of printing the report for a particular item number, you can ask that it print for multiple items by using F02 and going to display AMEF42.

Note: This display has three substitutes that can appear depending on the functions selected during application tailoring:

- AMEF45 appears if the Routing file was selected but feature/options were not selected.
- AMEF46 appears if neither feature/options nor the Routing file were selected.
- AMEF47 appears if feature/options were selected but the Routing file was not selected.

```

DATE **/**/**      RETRIEVAL SELECTIONS - REGULAR      SELECT      AMEF41  **
                   --SINGLE LIST--

                                ENTER--
                                RUN OPTION  A
                                ITEM         aaaaaaaaaaaaaA15      1-6,8 (REQD)
                                QUANTITY    nnnnnnnn                1-3,8
                                S-NUMBER     aaaaaaaaaaaaaaaA20      1,2,8
                                FACILITY ID  aaaA5                    7 (REQD)
                                EFFEC DATE  nnnnnn                    1-5,8

RUN OPTIONS

1 SINGLE LEVEL BILL WITH BLOW-THROUGH
2 INDENTED BILL
3 SUMMARIZED BILL
4 SINGLE LEVEL WHERE-USED
5 END-ITEM WHERE-USED
6 ROUTING
7 FACILITY WHERE-USED
8 ROUTING & SINGLE LEVEL WITH BLOW-THROUGH

                                F02 MULTI-LIST OPTIONS
                                F24 END OF JOB

```

What to do

- To print a regular single-list report, type in the information requested and press **Enter**. PDM schedules the report to be printed.
- To print a regular multi-list report (for multiple parent items), use **F02**. Go to display AMEF42.

Function keys

F02 MULTI-LIST OPTIONS ignores any data you just entered and causes display AMEF42 to appear.

F24 END OF JOB ignores any data you just entered and causes the Reports menu (AMEM03) to appear again.

Fields

[?] appears next to a field name in the following field definitions to identify a field from which you can begin a master file search.

RUN OPTION. Required. To select the report type you want, type in one of the run option numbers (1 through 8) shown in the lower left of the display.

ITEM (ITNBR) [?]. Required for all run options except 7. Type in an item number for all run options (1 through 6 and 8) except 7.

QUANTITY. If you chose a run option of 1, 2, 3, or 8, you can type in a quantity of up to 99,999,999 to indicate how many units of the item you want to see. For example, if the standard batch quantity is 100 and you want to see 900 units, type in 900. The default is 1. A quantity of 1 is assumed for the other options (4, 5, 6, 7).

S-NUMBER [?]. You can specify an S-number if the item is an end-item. If you do not type in an S-number, all options for all features for an end-item are printed on the report. For a specific feature, if you type in an asterisk, all options for that feature are printed on the report.

If you enter a zero or blanks in this field for a nonrequired feature, that feature and its associated options are not printed.

FACILITY ID (WKCTR) [?]. Required for run option 7. Type in the facility ID only if you selected run option 7.

EFFEC DATE (Effective Date). If you type in an effective date (only for run options 1 through 5 or 8), only the components that are effective as of that date are printed. If you do not type in an effective date, all components of the item (regardless of effective dates) are printed.

AMEF42—Retrieval Selections—Regular—Multi List (Select)

Use this display to select the limits for printing the Multi-List Retrieval reports.

This display appears when you select **F02** (Multi-list Options) on any of the following displays: AMEF41, AMEF45, AMEF46, or AMEF47.

This display allows you to select run options that include: single level bill by item, indented bill for all end items, end item where-used by vendor, end item where-used by items with no components, or routing operations by item. Or, you can select to print only single items by using **F01** and going back to display AMEF41 (or AMEF45, AMEF46, or AMEF47). You can select to see all items or items within limits, and all vendors or vendors within limits.

```

DATE **/**/**      RETRIEVAL SELECTIONS - REGULAR      SELECT      AMEF42  **
                    --MULTI LIST--

                                ENTER--
                                RUN OPTION A
                                FROM ITEM  aaaaaaaaaaaaaA15  ALL
                                TO ITEM    aaaaaaaaaaaaaA15  ALL
                                VENDOR NO  aaaaA6             3
                                EFFEC DATE nnnnnn            1-4

                                APPLIES
                                TO--

RUN OPTIONS

1 SINGLE LEVEL BILL BY ITEM
2 INDENTED BILL FOR ALL END-ITEMS
3 END-ITEM WHERE-USED BY VENDOR
4 END-ITEM WHERE-USED BY ITEMS WITH NO COMPONENTS
5 ROUTING OPERATIONS BY ITEM

                                F01 SINGLE LIST OPTIONS
                                F24 END OF JOB

```

What to do

- To print a regular multi list report, type in the information requested and press **Enter**. PDM schedules the report to be printed.
- To print a regular single-list report (for a single parent item), use **F01**. Go back to the display on which you used F02.

Function keys

F01 SINGLE LIST OPTIONS ignores the data you just entered and causes the display (AMEF41, AMEF45, AMEF46, or AMEF47) that you were on when you selected **F02** to appear again.

F24 END OF JOB ignores the data you just entered and causes the Reports menu (AMEM03) to appear again.

Fields

[?] appears next to a field name in the following field definitions to identify a field from which you can begin a master file search.

[Contents](#)[Index](#)

RUN OPTION. Required. To select the report type you want, type in one of the options (1, 2, 3, 4, or 5) shown in the bottom left of the display.

FROM ITEM (ITNBR) TO ITEM (ITNBR) [?]. You can specify the limits of the report by typing in from and/or to item numbers. If you do not specify any limits, all items are included on the report.

VENDOR NO (VNDNR) [?]. If you select run option 3, you can specify a vendor number. If you do not type in a vendor number for run option 3, items for all vendors are included on the report.

EFFEC DATE (Effective Date). If you type in an effective date (only for run options 1 through 4), only the components that are effective as of that date are printed. If you do not type in an effective date, all components of the items selected (regardless of effectivity dates) are printed.

AMEF45—Retrieval Selections—Regular—Single List (Select)

Use this display to select the limits for printing the Single List Retrieval reports.

This display appears when you select option 5 (Retrieval Selections—Regular) on the Reports menu (AMEM03) and if the Routing file was selected during application tailoring and feature/options was not selected.

This display is identical in function to display AMEF41, except that it does not provide for S-number entry.

```

DATE **/**/**          RETRIEVAL SELECTIONS - REGULAR          SELECT          AMEF45  **
                        --SINGLE LIST--

                                ENTER--
                                RUN OPTION  A
                                ITEM          aaaaaaaaaaaaaA15  1-6,8 (REQD)
                                QUANTITY     nnnnnnnn          1-3,8
                                FACILITY ID   aaaA5              7 (REQD)
                                EFFEC DATE   nnnnnn              1-5,8

RUN OPTIONS

1 SINGLE LEVEL BILL WITH BLOW-THROUGH
2 INDENTED BILL
3 SUMMARIZED BILL
4 SINGLE LEVEL WHERE-USED
5 END-ITEM WHERE-USED
6 ROUTING
7 FACILITY WHERE-USED
8 ROUTING & SINGLE LEVEL WITH BLOW-THROUGH

                                F02 MULTI-LIST OPTIONS
                                F24 END OF JOB

```

What to do

- To print a regular single-list report, type in the information requested and press **Enter**. PDM schedules the report to be printed.
- To print a regular multi-list report (for multiple parent items), use F02. Go to display AMEF42.

Function keys

F02 MULTI-LIST OPTIONS ignores any data you just entered and causes display AMEF42 to appear.

F24 END OF JOB ignores any data you just entered and causes the Reports menu (AMEM03) to appear again.

Fields

[?] appears next to a field name in the following field definitions to identify a field from which you can begin a master file search.

RUN OPTION. Required. To select the report type you want, type in on of the run option numbers (1 through 8) shown in the lower left of the display.

Contents

Index

ITEM (ITNBR) [?]. Required for all options except 7. Type in an item number for all run options (1-6 and 8), except 7.

QUANTITY. If you chose a run option of 1, 2, 3, or 8, you can type in a quantity of up to 99,999,999 to indicate how many units of the item you want to see. For example, if the standard batch quantity is 100 and you want to see 900 units, type in 900. The default is 1. A quantity of 1 is assumed for the other options (4, 5, 6, 7).

FACILITY ID (WKCTR) [?]. Required for option 7. Type in the facility ID only if you selected run option 7.

EFFEC DATE (Effective Date). If you type in an effective date (only for options 1-5 or 8), only the components that are effective as of that date are printed. If you do not type in an effective date, all components of the item (regardless of effectivity dates) are printed.

AMEF46—Retrieval Selections—Regular—Single List (Select)

Use this display to select the limits for printing the Single List Retrieval reports.

This display appears when you select option 5 (Retrieval Selections— Regular) on the Reports menu (AMEM03) and neither feature/options nor the Routing file was selected during application tailoring.

This display is identical in function to display AMEF41, except that it does not provide for S-number, routing, or facility ID entry.

```

DATE **/**/**      RETRIEVAL SELECTIONS - REGULAR      SELECT      AMEF46  **
                   --SINGLE LIST--

                                ENTER--
                                RUN OPTION  A
                                ITEM          aaaaaaaaaaaaA15  ALL (REQD)
                                QUANTITY      nnnnnnnn          1-3
                                EFFEC DATE    nnnnnn             ALL

RUN OPTIONS

1 SINGLE LEVEL BILL WITH BLOW-THROUGH
2 INDENTED BILL
3 SUMMARIZED BILL
4 SINGLE LEVEL WHERE-USED
5 END-ITEM WHERE-USED

                                F02 MULTI-LIST OPTIONS
                                F24 END OF JOB

```

What to do

- To print a regular single-list report, type in the information requested and press **Enter**. PDM schedules the report to be printed.
- To print a regular multi-list report (for multiple parent items), use **F02**. Go to display AMEF42.

Function keys

F02 MULTI-LIST OPTIONS ignores any data you just entered and causes display AMEF42 to appear.

F24 END OF JOB ignores any data you just entered and causes the Reports menu (AMEM03) to appear again.

Fields

[?] appears next to a field name in the following field definitions to identify a field from which you can begin a master file search.

RUN OPTION. Required. To select a report, type in the code for the report you want (1 through 5).

[Contents](#)[Index](#)

ITEM (ITNBR) [?]. Required. You must type in an item number for any run option (1 through 5) selected.

QUANTITY. If you chose a run option of 1, 2, or 3, you can type in a quantity of up to 99,999,999 to indicate how many units of the item you want to see. For example, if the standard batch quantity is 100 and you want to see 900 units, type in 900. The default is 1. A quantity of 1 is assumed for the other options (4 and 5).

EFFEC DATE (Effective Date). If you type in an effective date (for any run option selected); only the components that are effective as of that date are printed. If you do not type in an effective date, all components of the item (regardless of the effectivity dates) are printed.

AMEF47—Retrieval Selections—Regular—Single List (Select)

Use this display to select the limits for printing the Single List Retrieval reports.

This display appears when you select option 5 (Retrieval Selections—Regular) on the Reports menu (AMEM03) and if feature/options were selected and the Routing file was not selected during application tailoring.

This display is identical in function to display AMEF41, except that it does not provide for Routing or Facility ID entry.

```

DATE **/**/**          RETRIEVAL SELECTIONS - REGULAR          SELECT          AMEF47  **
                        --SINGLE LIST--

                                ENTER--
                                RUN OPTION  A
                                ITEM          aaaaaaaaaaaaaA15
                                QUANTITY      nnnnnnnn
                                S-NUMBER      aaaaaaaaaaaaaA20
                                EFFEC DATE    nnnnnn
                                APPLIES
                                TO--

RUN OPTIONS

1 SINGLE LEVEL BILL WITH BLOW-THROUGH
2 INDENTED BILL
3 SUMMARIZED BILL
4 SINGLE LEVEL WHERE-USED
5 END-ITEM WHERE-USED

                                F02 MULTI-LIST OPTIONS
                                F24 END OF JOB

```

What to do

- To print a regular single-list report, type in the information requested and press **Enter**. PDM schedules the report to be printed.
- To print a regular multi-list report (for multiple parent items), use **F02**. Go to display AMEF42.

Function keys

F02 MULTI-LIST OPTIONS ignores any data you just entered and causes display AMEF42 to appear.

F24 END OF JOB ignores any data you just entered and causes the Reports menu (AMEM03) to appear again.

Fields

[?] appears next to a field name in the following field definitions to identify a field from which you can begin a master file search.

RUN OPTION. Required. To select a report, type in the code for the report you want (1 through 5).

[Contents](#)[Index](#)

ITEM (ITNBR) [?]. Required. You must enter an item number for any run option selected.

QUANTITY. If you chose a run option of 1, 2, or 3, you can type in a quantity of up to 99,999,999 to indicate how many units of the item you want to see. For example, if the standard batch quantity is 100 and you want to see 900 units, type in 900. The default is 1. A quantity of 1 is assumed for the other options (4 and 5).

S-NUMBER [?]. You can type in an S-number if the item is an end-item with features and you selected run option 1 or 2. If you do not type in an S-number, all options for all features for that end-item are printed on the report.

EFFEC DATE (Effective Date). If you type in an effective date (for any run option selected); only the components that are effective as of that date are printed. If you do not type in an effective date, all components for the item (regardless of effectivity dates) are printed.

Option 6. Retrieval Selection – Costed (AMEM03)

Use this option anytime you need one of the costed retrieval reports.

Note: You can print these reports only if product costing was selected during application tailoring.

This set of reports is similar to regular retrieval selections except cost data is printed instead of engineering data.

What information you need: None.

What reports are printed: One of the following reports is printed depending upon the option you choose on one of the Retrieval Selections—
Costed (Select) displays:

- Single Level Cost Sheet—Current or Standard, Single or Multi-Item, with or without Blow-Through (AMEG71)
- Indented Cost Sheet—Current or Standard (AMEG72)
- Operations Cost Sheet—Current (AMEH41)
- Operations Cost Sheet—Standard (AMEH42)
- Management Cost Summary—Current or Standard (AMEH7)
- Cost Variations—Current to Standard (AMEH8).

What forms you need: None.

AMEF43—Retrieval Selections—Costed—Single List (Select)

Use this display to select the limits for printing the Single List Costed Retrieval reports.

This display appears when you select option 6 (Retrieval Selections—Costed) on the Reports menu (AMEM03) and PDM product costing was selected during system tailoring.

Note: The Operation Cost Sheets are printed only if the Routing file was selected during application tailoring.

This display allows you to select run options which include: single level current, single level standard, indented current, indented standard, operations cost sheet current, operations costs sheet standard. Or, instead of printing the report for a particular item number, you can print for multiple items by using **F04** and going to display AMEF44. The operations cost sheets are available only if you are using the Routing file.

```

DATE **/**/**      RETRIEVAL SELECTIONS - COSTED      SELECT      AMEF43  **
                   --SINGLE LIST--

                                ENTER--
                                RUN OPTION  A
                                ITEM          aaaaaaaaaaaaaA15      ALL (REQD)
                                QUANTITY     nnnnnnnn          7, 8
                                EFFEC DATE   nnnnnn           ALL
                                S-NUMBER     aaaaaaaaaaaaaA20    1,2,3,4,7,8

RUN OPTIONS

1 SINGLE LEVEL CURRENT
2 SINGLE LEVEL STANDARD
3 SINGLE LEVEL CURRENT WITH BLOW-THROUGH
4 SINGLE LEVEL STANDARD WITH BLOW-THROUGH
5 INDENTED CURRENT
6 INDENTED STANDARD
7 OPERATIONS COST SHEET CURRENT
8 OPERATIONS COST SHEET STANDARD

                                F05 MULTI-LIST OPTIONS
                                F24 END OF JOB

```

What to do

- To print a costed single-list report, type in the information requested and press **Enter**. PDM schedules the report to be printed.
- To print a costed multi-list report (for multiple parent items), use **F05**. Go to display AMEF44.

Function keys

F05 MULTI-LIST OPTIONS ignores the data you just entered and causes display AMEF44 to appear.

F24 END OF JOB ignores the data you just entered and causes the Reports menu (AMEM03) to appear again.

Fields

[?] appears next to a field name in the following field definitions to identify a field from which you can begin a master file search.

RUN OPTION. Required. To select a report, type in the code for the report you want (1 through 6).

ITEM (ITNBR) [?]. Required. For any run option selected (1-6), you must enter an item number.

QUANTITY. If you chose a run option of 7 or 8, you can type in a quantity of up to 99,999,999 to indicate how many units of the item you want to see. For example, if the standard batch quantity is 100 and you want to see 900 units, type in 900. The default is 1. A quantity of 1 is assumed for the other options (1 through 4).

EFFEC DATE (Effective Date). If you type in an effective date (for any run option selected), only the components that are effective as of that date are printed. If you do not type in a date, the date last costed, current or standard (CURDT or STDDT), is assumed.

S-NUMBER [?]. required for run options 1, 2, 5, or 6. You must type in an S-number if the item is an end-item with features and if you selected run option 1, 2, 5, or 6. You cannot type in asterisks or blanks on this display.

AMEF44—Retrieval Selections—Costed—Multi List (Select)

Use this display to select the limits for printing the Multi-List Retrieval reports.

This display appears when you select **F04** (Multi-list Options) on display AMEF43.

This display allows you to select run options which include single level current, single level standard, indented current, indented standard, management cost summary current, management cost summary standard, and costs variations current to standard. You can choose to see all items printed (both end items and items used in a bill of material) or items within limits. You also can choose to print only single items by using **F03** and returning to display AMEF43.

Note: Only end items or items used in a bill of material are printed. To include a purchased item that is not part of a bill of material on the report, make the item an item type 9 and give it a “dummy” phantom component.

```

DATE **/**/**      RETRIEVAL SELECTIONS - COSTED      SELECT      AMEF44  **
                    --MULTI LIST--

                                ENTER--
                                RUN OPTION A
                                GROUPING  A
RUN OPTIONS          FROM ITEM  aaaaaaaaaaaaA15  I,N
                                TO ITEM  aaaaaaaaaaaaA15  ALL
                                EFFEC DATE nnnnnn      1-6
1 SINGLE LEVEL CURRENT
2 SINGLE LEVEL STANDARD
3 SINGLE LEVEL CURRENT WITH BLOW-THROUGH
4 SINGLE LEVEL STANDARD WITH BLOW-THROUGH
5 INDENTED CURRENT
6 INDENTED STANDARD
7 MANAGEMENT COST SUMMARY CURRENT
8 MANAGEMENT COST SUMMARY STANDARD
9 COST VARIATIONS CURRENT TO STANDARD

GROUPING
I ALL ITEMS
N END-ITEMS ONLY

                                F03 SINGLE LIST OPTIONS
                                F24 END OF JOB

```

What to do

- To print a costed multi-list report, type in the information requested and press **Enter**. PDM schedules the report to be printed.
- To print a costed single-list report (for a single parent item), use **F03**. Go to display AMEF43.

Function keys

F03 SINGLE LIST OPTIONS ignores the data you just entered and causes display AMEF43 to appear.

F24 END OF JOB ignores the data you just entered and causes the Reports menu (AMEM03) to appear again.

Fields

[?] appears next to a field name in the following field definitions to identify a field from which you can begin a master file search.

RUN OPTION. Required. To select a report, type in the code for the report you want (A through G), as shown on the left side of the display.

GROUPING. If you want to print both end-items and items used in a bill of material on a report, no entry is necessary. The default is 1. If you want to specify end-items only, type in **N**.

Note: End-items are defined as those items with assembly components, but without where-used chains. Only end-items or items used in a bill of material are printed. To include on the report a purchased item that does not have a component or is not part of a bill of material, make the item an item type **9** and give it a dummy phantom component.

FROM ITEM (ITNBR) ITEM (ITNBR) [?]. Type in the item number or numbers you want to print on the report. If the **TO ITEM** field is blank, all items starting with the **FROM ITEM** number to the last item number are printed. If the **FROM ITEM** field is blank, all items starting with the first item number up to and including the **TO ITEM** number are printed. If both fields are blank, all item numbers are printed.

EFFEC DATE (Effective Date). If you type in an effective date (only for run options A through D), only the components that are effective as of that date are printed. If you do not type in a date, the date last costed, current or standard (CURDT or STDDT), is assumed.

Option 7. WIP Cost Worksheet (AMEM03)

Use this option anytime you want to print a Work-in-Process Cost Worksheet using standard, current, or average cost information.

This report shows the build up of cost value of the parent item at the end of each operation step and is used to calculate the value of the work-in-process.

What information you need: None.

What reports are printed: Work-in-Process Cost Worksheet—Current, Standard, or Average Costs (AME86).

What forms you need: None.

AME751—WIP Cost Worksheet (Select)

Use this display to select the item number range, the type of costing, and the effective date you want to use for printing the Work-in-Process Cost Worksheet report. This report shows the build up of cost value of the parent item at the end of each operation step. It is used to calculate the value of the work in process.

This display appears when you select option 7 (WIP Cost Worksheet) on the Reports menu (AMEM03).

This display allows you to select the report format. You can have this report print some or all items using standard, current, or average information. You also can enter an effectivity date for the bill of material. If you do not enter an effectivity date, PDM uses the system date.

```

DATE **/**/**          WIP COST WORKSHEET          SELECT    AME751  **

ITEM NUMBER  FROM:  aaaaaaaaaaaaaA15
              TO:   aaaaaaaaaaaaaA15
TYPE OF COST
STANDARD    - S
CURRENT     - C
AVERAGE     - A

QUANTITY:    nnnnnnn
EFFECTIVE DATE:  nnnnnn

F24 CANCEL

```

What to do

To print the Work-in-Process Cost Worksheet, type in the requested information and press **Enter**. PDM schedules the report to be printed.

Function keys

F24 CANCEL cancels the job and causes the Reports menu (AMEM03) to appear again.

Fields

[?] appears next to a field name in the following field definitions to identify a field from which you can begin a master file search.

Contents

Index

ITEM NUMBER (ITNBR)

FROM/TO [?]. Type in the item number or numbers you want to print on the report. If the **TO** field is left blank, all items starting with the **FROM** number to the last item number are printed. If the **FROM** field is left blank, all items starting with the first item number up to and including the **TO** number are printed. If both fields are blank, all item numbers are printed.

TYPE OF COST. Required. Type in one of the following codes to indicate the type of costing you want to use on the report. This selection also affects yield calculations.

- S** Standard. Use standard rates and overhead code from work center and standard efficiency.
- C** Current. Use current rates and overhead code from work center and standard efficiency.
- A** Average. Use current rates and overhead code from work center and average efficiency.

QUANTITY. The number of batches (standard batch quantity) of the parent item to be manufactured.

EFFECTIVE DATE. Type in a costing date for this simulation. If **TYPE OF COST** is S, the default is the date last costed—standard. If **TYPE OF COST** is C, the default is the date last costed—current. If **TYPE OF COST** is A, the default is the system date.

Option 8. Item Foreign Language Description (AMEM03)

Use this option to print item reports, showing either items with foreign language descriptions or items without foreign language descriptions.

What information you need: None.

What reports are printed:

- Items with Foreign Language Descriptions (AMVD1PFR)
- Items without Foreign Language Descriptions (AMVDYPFR)

For more information about these reports, see the *Customer Order Management User's Guide*.

What forms you need: None.

[Contents](#)[Index](#)

AMEPT8—Item Foreign Language Descriptions

Use this display to select either the Items with Foreign Language report or the Items without Foreign Language report for printing.

This display appears when you select option 8 (Item Foreign Language Descriptions) on the Reports menu (AMEM03).

```
Date **/**/**          Item Foreign Language Descriptions          AMEPT8  **

Select one of the following . . . _  1. Items With Foreign Language Desc
                                       2. Items Without Foreign Language Desc

F3=Exit
```

What to do

Type in the information required and press **Enter**.

Function keys

F3=Exit cancels the job and causes the Reports menu (AMEM03) to appear again.

Fields

Select one of the following. Type in one of the following to print a report.

- 1 Items with Foreign Language Description
- 2 Items without Foreign Language Description.

Chapter 5. Costing

When you select option 3 on the Main Menu (AMEM00) the Costing menu (AMEM04) appears if product costing was selected during application tailoring. This menu allows you to recost items and print product costing reports using standard or current costs, or both.

Costing updates the cost fields in the Item Master B-record by building the costs from the lowest level of each product structure and rolling them up to the top. There are two techniques used to calculate this-level labor and labor overhead costs for an item using the cost technique code:

- R** Uses standard hours in the Routing file and rates in the Production Facility file
- T** Uses the labor hours and table code fields in the Item Master record, and the rates and percentages in the Labor/ Overhead Table (a record in the System Control file).

For more information on costing techniques, see Chapter 2 “Managing Product Data Management”. Costing also allows you to simulate the above and see the results without actually updating the cost fields in the Item Master file.

Costing allows three kinds of product costing and three kinds of product costing simulation:

- Current
- Standard
- Both current and standard.

Euro currency considerations. If your company has converted from a euro-participating local currency to euro currency, the costing amounts in the Item Revision, Routing Operations, and Production Facility files may be slightly changed. These changes would be due to minor differences in the way euro amounts are rounded versus the way amounts were rounded in the local currency.

Also, if your company has converted your local currency to euro, you need to perform a full costing run for either Current or Standard costs or both types of costs. The costing run will update these costs with the detail costs that have been converted to euro.

If product costing was not selected during application tailoring and you select options 1 through 7, you are returned to the Main Menu (AMEM00). If you select option 8 or 9, display AMVX71 appears. If you select option 10 or 11, display AMVX72 appears. If you select option 12, display AME4601 appears.

Options 1 — 3. Product Costing—Current/Standard/Both (AMEM04).....	5-4
Options 4 — 6. Simulate Product Cost—Current/Standard/Both (AMEM04).....	5-7
Option 7. Item Cost Percent Change (AMEM04)	5-23
Option 8. Change L/O Costing Table (AMEM04).....	5-26
Option 9. Change L/O Simulation Costing Table (AMEM04).....	5-29
Option 10. Change P/O Costing Table (AMEM04)	5-31
Option 11. Change P/O Simulation Costing Table (AMEM04).....	5-34
Option 12. Roll Current to Standard Costs (AMEM04).....	5-36

```

AMEM04                                Product Data Management          *****
                                      Costing

Type option or command; press Enter.

  1. Product Costing-Current
  2. Product Costing-Standard
  3. Product Costing-Both
  4. Simulate Product Cost-Current
  5. Simulate Product Cost-Standard
  6. Simulate Product Cost-Both
  7. Item Cost Percent Change
  8. Change L/O Costing Table
  9. Change L/O Simulation Costing Table
 10. Change P/O Costing Table
 11. Change P/O Simulation Costing Table
 12. Roll Current to Standard Costs

==> _____

F3=Exit      F4=Prompt    F9=Retrieve   F10=Actions
F11=Job status F12=Return   F22=Messages

```

Options 1-3: Product Costing - Current, Standard, Both. Use options 1–3 to perform current or standard product costing or both.

Options 4-6: Simulate Product Cost - Current, Standard, Both. Use options 4–6 to simulate current or standard cost maintenance or both on the Item Master or Production Facility files without actually updating them by entering simulation transactions. Product Costing is then run against these simulated transactions and a simulated report is printed for current cost.

Option 7. Item Cost Percent Change. Use this option to change the purchase content of all items or all items in a specific item class.

Option 8. Change L/O Costing Table. Use this option to change labor rates, labor overhead rates, and labor overhead percentages that are used with any item's labor hours field if that item's cost technique code is T when Product Costing is run.

Option 9. Change L/O Simulation Costing Table. Use this option to simulate changes to the Labor/Overhead table and run Simulate Product Costing to see the results.

Option 10. Change P/O Costing Table. Use this option to change the purchase overhead percentages that are used with any item's purchase unit cost field when Product Costing is run.

Option 11. Change P/O Simulation Costing Table. Use this option to simulate changes to the Purchase Overhead table and run Simulate Product Costing to see the results.

Option 12. Roll Current to Standard Costs. Use this option to roll costs from current to standard at any desired point in time. Normally this function is used in preparation for starting a new year. A confirmation display appears before any action is taken.

Full and selective costing

If you select options 1, 2, or 3 from AMEM04, you can do a full or selective costing run. Full costing is used to cost all products. Selective costing is used to complete a full costing run by costing items with incomplete costs, to cost new items, and to cost single items.

You can do a full costing run for current costs, standard costs, or both. The new costs are calculated and used to update the cost fields in the Item Master file.

During a full costing run, the cost elements of every item are analyzed. Any inconsistencies between an item's cost elements and its item type and cost technique code are noted by messages on the costing reports. You should correct the costing problems indicated by the messages and then run selective costing to correct the item's cost fields in the Item Master file.

After you enter the kind of costing you want to do, the application sends your request to the job queue to be run in batch mode. After the cost fields are updated in the Item Master file, the updated costing reports are printed. When you select options 1, 2, or 3, you see display AMEJ78.

Simulating product cost

You can simulate changes to your products' costs using options 4, 5, or 6 by entering changes to:

- Material this-level by item
- Rates by facility
- Percentages applied to either material this-level or facility rate.

If you select option 4 from AMEM04, you can simulate current costs. If you select option 5, you can simulate standard costs. And if you select option 6, you can simulate both. If you want to simulate changes in the Labor/Overhead Table or the Purchase Overhead Table, you must first make your simulated changes to the Labor/Overhead Simulation Table or the Purchase Overhead Simulation Table using options 9 or 11 before choosing options 4, 5, or 6.

You do not update the Item Master file when you use simulation. After you have finished entering the set of simulation transactions you want, they are applied to a dummy Item Master file, cost roll-up is done, and the product costing simulation report is printed. The report shows old and proposed new costs for your items.

Options 1 — 3. Product Costing—Current/Standard/Both (AMEM04)

Use these options anytime you want to run current and/or standard product costing (full or selective) to recost some or all of your company's products.

Note: You can run current product costing only if product costing was selected during application tailoring.

What information you need:

- If you are doing selective costing for an item, the item number of the item you want to cost
- If your costing date is different from the system date, the costing date you want to use.

What printed: Product Cost Update Report—Current or Standard Costs (AMEI30).

What forms you need: None.

AMEJ78—Product Costing—Both Current and Standard (Select)

Use this display to enter the type of product costing (full or selective) and the costing date you want to use.

This display appears when you select options 1, 2, or 3 on the Costing menu (AMEM04).

This display allows you to enter the costing date and the type of product costing you want to use. The costing date is used to compare against the effective dates in the Product Structure records to determine which ones are effective as of that costing date. This field is optional and if you do not enter a date, the costing date defaults to the system date.

You can select either a full or selective costing run. If you select a full costing run, all products are costed. If you select a selective costing run, you need to indicate the items you want costed. Three selections for types of selective costing are available:

- If you choose selection 1 (AN INDIVIDUAL ITEM), you must enter the item number of the item you want costed.
- If you choose selection 2 (ALL NEW ITEMS), all items entered after the last full costing run are costed.
- If you choose selection 3 (ALL ITEMS WITH INCOMPLETE COSTS), all items with Cost Status codes D, T, and L are costed. An example of an item with incomplete costs is a manufactured item with no labor content.

Note: Kits are excluded from all costing.

```

DATE **/**/**                PRODUCT COSTING                SELECT    AMEJ78  **
                             --BOTH CURRENT AND STANDARD--
ENTER COSTING DATE                nnnnnn
CHOOSE THE TYPE OF COSTING RUN    n
  1. SELECTIVE COSTING RUN
  2. FULL COSTING RUN

CHOOSE THE TYPE OF SELECTIVE COSTING  n
  1. AN INDIVIDUAL ITEM
    ENTER ITEM NUMBER                aaaaaaaaaaaaA15
  2. ALL NEW ITEMS
  3. ALL ITEMS WITH INCOMPLETE COSTS

SUPPRESS WARNING MESSAGES ON COSTING REPORT? (Y/N)    A

                                     F24 END COSTING

```

What to do

- To run selective costing, type **1** in the **CHOOSE THE TYPE OF COSTING RUN** field. Do one of the following:
 - To cost an individual item, type **1** in the **CHOOSE THE TYPE OF SELECTIVE COSTING** field and the item number in the **ENTER ITEM NUMBER** field.

Press **Enter**. You can enter additional item numbers and they will all be recosted together. PDM schedules the report for printing.

- To cost all new items, type **2** in the **CHOOSE THE TYPE OF SELECTIVE COSTING** field. Press **Enter**. PDM schedules the report for printing.
- To cost all items with incomplete costs, type **3** in the **CHOOSE THE TYPE OF SELECTIVE COSTING** field. Press **Enter**. PDM schedules the report for printing.
- To run full costing, type **2** in the **CHOOSE THE TYPE OF COSTING RUN** field. Press **Enter**. PDM schedules the report for printing.

Function keys

F24 END COSTING submits the job for costing if you selected option 1 for the **CHOOSE THE TYPE OF COSTING RUN** field and option 1 for the **CHOOSE THE TYPE OF SELECTIVE COSTING** field and pressed Enter. If you selected any of the other options, using F24 ignores the data you just typed in and causes the Costing menu (AMEM04) to appear again. Product Costing is not run.

Fields

[?] appears next to a field name in the following field definitions to identify a field from which you can begin a master file search.

ENTER COSTING DATE. You can change the date (today's date) that appears when this display first appears, if you want to use another costing date.

CHOOSE THE TYPE OF COSTING RUN. This field is required. Type in one of the following numbers to choose the kind of product costing run you want to do:

- 1 Selective costing run
- 2 Full costing run.

A full costing run costs all items. If you want to do a selective costing run, you must choose the items you want to cost.

CHOOSE THE TYPE OF SELECTIVE COSTING. This field is required if you choose selective costing. Type in one of the following numbers to choose the items you want to cost:

- 1 An individual item—only one item is costed. Additional item numbers can be entered.
- 2 All new items—all items that have been entered in the Item Master file after the last full costing run are costed.
- 3 All items with incomplete costs—all items with cost status codes D, T, and L are costed. An example of incomplete costs is a manufactured item with no labor content.

ENTER ITEM NUMBER [?]. This field is required if you choose selection 1. Type in the item number of the item you want to cost.

SUPPRESS WARNING MESSAGE ON COSTING REPORT? (Y/N). Accept the default of N if you want to see warning messages on the costing report. Type Y if you do not want to see warning messages on the costing report.

Options 4 — 6. Simulate Product Cost—Current/Standard/Both (AMEM04)

Use these options anytime you want to simulate current and/or standard product costing. You can simulate entering changes to the Item Master and Production Facility files without actually changing them and then do a simulated current product costing run against these transactions.

Note: You can simulate current product costing only if product costing was selected during application tailoring.

What information you need: None.

What reports are printed: Product Cost Simulation—Current or Standard Costs—
After Change by Item, Facility, Percent, Costing Date, or Average (AMEI31).

What forms you need: None.

AMEJ70—Product Cost Simulation (Select)

Use this display to select the type of product costing simulation you want to run.

This display appears when you select options 4, 5, or 6 on the Costing menu (AMEM04).

Five selections are available on this display for you to further define how you want to run your simulation. Once you have selected one of the five selections on the simulation transaction entry display, you cannot return to the select display directly.

```

DATE **/**/**          PRODUCT COST SIMULATION          SELECT  AMEJ70  **
                        --BOTH CURRENT AND STANDARD--

MAKE ONE OF THE FOLLOWING CHANGES PRIOR TO SIMULATION

1 - CHANGE BY ITEM
  MATERIAL THIS LEVEL
2 - CHANGE BY FACILITY
  MACHINE, RUN LABOR, SETUP LABOR, OR OVERHEAD
3 - CHANGE BY PERCENT
  MATERIAL THIS LEVEL - I/M
  MACHINE, RUN LABOR, SETUP LABOR, OR OVERHEAD - FAC
4 - USE AVERAGE YIELD
5 - NONE OF THE ABOVE

ENTER SELECTION FOR SIMULATION  n

ENTER COSTING DATE           nnnnnn

SUPPRESS WARNING MESSAGES ON COSTING REPORT?  (Y/N)  A

                                         F24 CANCEL

```

What to do

Note: If your costing date is different from the system date, type in the date you want to use.

- To simulate a change in the material this-level by item, type **1** in the **ENTER SELECTION FOR SIMULATION** field. Press **Enter**. Go to display AMEJ71.
- To simulate a change in a facility's machine rate, run labor rate, setup labor rate, overhead code, or overhead rate or percentage, type **2** in the **ENTER SELECTION FOR SIMULATION** field. Press **Enter**. Go to display AMEJ74.
- To simulate a percentage change by item or facility, type **3** in the **ENTER SELECTION FOR SIMULATION** field. Press **Enter**. Go to display AMEJ77.
- To simulate a change in the material, labor, and overhead content this-level using average yield, type **4** in the **ENTER SELECTION FOR SIMULATION** field. Press **Enter**. PDM schedules the report for printing.
- To see the effect on current product cost after you change the Labor/Overhead Simulation Table or after you change the cost fields in the Item Master, Product Structure, Production Facility, or Routing files, type **5** in the **ENTER SELECTION FOR SIMULATION** field. Press **Enter**. PDM schedules the report for printing.

Function keys

F24 CANCEL ignores the data you just entered and causes the Costing menu (AMEM04) to appear again.

Fields

The ENTER COSTING DATE field is optional. The other fields are required.

ENTER SELECTION FOR SIMULATION. Five selections are available on this display for you to further define how you want to run your simulation.

After you choose one of the selections on the simulation transaction entry display, you cannot return directly to this Select display.

If you choose selection 1 (CHANGE BY ITEM), the material this-level for multiple items can be changed for simulation.

If you choose selection 2 (CHANGE BY FACILITY), the machine rate, run labor rate, setup labor rate, labor overhead code, and the labor overhead rate/percent fields for multiple facilities can be changed for simulation.

If you choose selection 3 (CHANGE BY PERCENT), many fields can be changed by the entered percentage. The material this-level can be changed by a percent for all items or items of a specified item class. If item class is asterisks, your change affects all items. Any changes entered into current or standard machine rate, run labor rate, setup labor rate, or labor overhead are always applied to all facilities.

If you choose selection 4 (USE AVERAGE YIELD), the material, labor, and labor overhead content this-level for all items can be changed for simulation to reflect average yield. This report compares current and average costs.

If you choose selection 5 (NONE OF THE ABOVE), the only field that can be entered is the COSTING DATE. COSTING DATE is an optional field for any of the options on the simulation select display. If a value is not entered, the costing date defaults to the system date. Use this option to see the effect of simulated cost changes after you change the Labor/Overhead Simulation Table, Purchase Overhead Simulation Table, or after you maintain cost fields in the Item Master, Product Structure, Production Facility, or Routing files.

Simulation runs after all the individual transactions or the percent change transaction have been entered. The results are printed on the Simulation Product Costing report.

ENTER COSTING DATE. Today's date is shown when this display first appears. You can change this date by typing over the date shown. The costing date is compared to effectivity dates to include or exclude a component.

SUPPRESS WARNING MESSAGE ON COSTING REPORT? (Y/N). Accept the default of N if you want the costing report to contain warnings when XA detects a problem with an item's costs. Type Y if you do not want to see warning messages on the costing report.

AMEJ71—Product Cost Simulation—Change by Item (Select)

Use this display to enter the item number for which you want to simulate changes in material costs to see the effect on product cost.

This is the first display to appear when you select 1 on display AMEJ70.

```
DATE **/**/**          PRODUCT COST SIMULATION          SELECT  AMEJ71  **
                        --CHANGE BY ITEM--

ITEM  aaaaaaaaaaaaaA15

F19 RETURN TO SELECT
```

What to do

To simulate cost changes for an item, type in the item number and press **Enter**. Go to display AMEJ72.

Function keys

F19 RETURN TO SELECT ignores the data you just entered and causes display AMEJ70 to appear again.

Fields

[?] appears next to a field name in the following field definitions to identify a field from which you can begin a master file search.

ITEM (ITNBR) [?]. Required. Type in the number of the item whose material you want to simulate changed.

AMEJ72—Product Cost Simulation—Change by Item (Enter)

Use this display to review the present material this-level for the item and to enter the simulation values you want to use for material this-level.

This display appears when you type a valid item number on display AMEJ71.

```

DATE **/**/**          PRODUCT COST SIMULATION          ENTER    AMEJ72  **
                        --CHANGE BY ITEM--

ITEM                   DESCRIPTION
*****               *****
MATERIAL THIS LEVEL   ** , ** , ** , ** . *****   ** , ** , ** , ** . *****
ENTER SIMULATION VALUE  nn , nnn , nnn , nnn . nnnnnnnn   nn , nnn , nnn , nnn . nnnnnnnn

                                                    F01 SELECT ANOTHER ITEM
    
```

What to do

- To simulate a change in the material for an item, type in the material this-level values you want to use. Press **Enter**. Go to display AMEJ73.
- To simulate product costing for another item, use **F01**. Go to display AMEJ73.

Function keys

F01 SELECT ANOTHER ITEM ignores the data you entered and causes the Product Costing Simulation (Review) display (AMEJ73) to appear to allow entry of the next item number.

Fields

ITEM (ITNBR). This field shows the number of the item for which you want to simulate changes in material this-level.

DESCRIPTION (ITDSC). This field shows the description of the item that normally appears on invoices, inquiries, and reports.

MATERIAL THIS LEVEL CURRENT (CMAT) and/or MATERIAL THIS LEVEL STANDARD (SMAT). This field shows the actual (Current and/or Standard) cost for this-level for the item.

ENTER SIMULATION VALUE. May be required for Current, Standard, or both, depending on the option you selected on the Costing menu (AMEM04). Type in the

[Contents](#)

[Index](#)

simulation value you want to use for MATERIAL THIS-LEVEL (current and/or standard).

If you selected option 4 (Simulate Product Cost—Current) on the Costing menu (AMEM04) you can enter simulation data for current costing. If you selected option 5 (Simulate Product Cost—Standard), you can enter simulation data for standard costing. If you selected option 6 for both, you can enter simulation data for both current and standard costing.

AMEJ73—Product Cost Simulation—Change by Item (Review)

Use this display to review both the present material this-level costs for the item and the simulation costs you entered on display AMEJ72. In addition, you can choose to enter the next item number for simulation, to end the program (F24), or to cancel simulation (F10).

This display appears if you made valid entries or selected F01 (Select Another Item) on display AMEJ72.

```

DATE **/**/**          PRODUCT COST SIMULATION          REVIEW   AMEJ73  **
                        --CHANGE BY ITEM--

ITEM                   DESCRIPTION
*****               *****
MATERIAL THIS LEVEL   CURRENT          STANDARD
SIMULATION VALUE ENTERED **,**,**,**,**.***** **,**,**,**,**.*****

NEXT ITEM
aaaaaaaaaaaaA15

F10 CANCEL SIMULATION
F24 END OF JOB
    
```

What to do

- To simulate a change for another item, type the item number in the **ITEM** field and press **Enter**. Return to display AMEJ72.
- To run product costing simulation, use **F24**. PDM schedules the report for printing.

Function keys

F10 CANCEL SIMULATION cancels the job and causes the Costing menu (AMEM04) to appear again.

F24 END OF JOB submits the Product Costing Simulation report to the job queue for printing and causes the Costing menu (AMEM04) to appear again.

Fields

[?] appears next to a field name in the following field definitions to identify a field from which you can begin a master file search.

The NEXT ITEM field is optional. The remaining fields are informational only; and you use them to review the information you entered in them on display AMEJ72. See that display for descriptions of these fields.

[Contents](#)

[Index](#)

NEXT ITEM (ITNBR) [?]. When you have completed review of the actual and simulated cost, you can type in the number of the next item whose material this-level you want to simulate changed.

AMEJ74—Product Cost Simulation—Change by Facility (Select)

Use this display to enter the ID of the facility for which you want to simulate changes in values (machine, run labor, setup labor, or labor overhead) to see the effect on product cost.

This is the first display that appears when you select 2 (Change by Facility) on display AMEJ70.

```
DATE **/**/**          PRODUCT COST SIMULATION          SELECT    AMEJ74  **
                        --CHANGE BY FACILITY--

FACILITY ID          aaaA5

F19 RETURN TO SELECT
```

What to do

To simulate a change by facility, type in the facility ID and press **Enter**. Go to display AMEJ75.

Function keys

F19 RETURN TO SELECT ignores the data you just entered and causes display AMEJ70 to appear again.

Fields

[?] appears next to a field name in the following field definitions to identify a field from which you can begin a master file search.

FACILITY ID (WKCTR) [?]. Required. Type in the ID of the facility for which you want to simulate changes.

AMEJ75—Product Cost Simulation—Change by Facility (Enter)

Use this display to review the percent values for this facility and to enter the simulation values for machine rate, run labor rate, setup labor rate, labor overhead code, and labor overhead.

This display appears when you enter a valid facility ID on display AMEJ74.

```

DATE **/**/**          PRODUCT COST SIMULATION          ENTER    AMEJ75  **
                        --CHANGE BY FACILITY--

FACILITY   DESCRIPTION
*****
                                CURRENT          STANDARD
MACHINE RATE          ** , *** . ***    ** , *** . ***
  ENTER SIMULATION VALUE  nn , nnn . nnn    nn , nnn . nnn
RUN LABOR RATE        ** , *** . ***    ** , *** . ***
  ENTER SIMULATION VALUE  nn , nnn . nnn    nn , nnn . nnn
SETUP LABOR RATE      ** , *** . ***    ** , *** . ***
  ENTER SIMULATION VALUE  nn , nnn . nnn    nn , nnn . nnn
OVERHEAD CODE         *
  ENTER SIMULATION CODE   A          A
OVERHEAD              ** , *** . ***    ** , *** . ***
  ENTER SIMULATION VALUE  nn , nnn . nnn    nn , nnn . nnn

                                F01 SELECT ANOTHER FAC

```

What to do

- To simulate a change by facility, type in the machine rate, run labor rate, setup labor rate, overhead code, and overhead rate or percentage. Press **Enter**. Go to display AMEJ76.
- To simulate current product costing for another facility, use **F01**. Go to display AMEJ76.

Function keys

F01 SELECT ANOTHER FAC ignores the data you entered and causes display AMEJ76 to appear to allow entry of the next facility.

Fields

The following fields are required: ENTER SIMULATION VALUE (CURRENT and/or STANDARD) for MACHINE RATE, RUN LABOR RATE, SETUP LABOR RATE, OVERHEAD CODE, and OVERHEAD.

The remaining fields are informational only. These fields are discussed first, followed by the required fields.

FACILITY (WKCTR). This field shows the ID of the facility whose rates and code you want to change to see the effect on Product Cost.

DESCRIPTION (WCDSC). This field shows the description of the facility. The following fields show the actual values from the master files.

MACHINE RATE (CMACH or SMACH). This rate, in cost per hour, is used with the run machine field of the associated routing to calculate the run machine cost. Product Data Management (PDM) product costing also uses this value to calculate overhead content this-level in the associated Item Master B-records. Type in the current and/or standard simulation values.

RUN LABOR RATE (CRLAB or SRLAB). This rate, in cost per hour, is used with the run labor field of the associated routing to calculate the run labor cost. PDM product costing also uses this value to calculate labor and overhead content this-level in the associated Item Master B-records. This field is not used in calculating run labor costs for routing operations with time basis code = C (outside operation).

SETUP LABOR RATE (CSLAB or SSLAB). This rate, in cost per hour, is used with the setup labor time field and setup crew size of the associated routing to calculate the setup labor cost. PDM product costing also uses this to calculate labor and labor overhead content this-level in the associated Item Master B-records. Type in the current and/or standard simulation values.

OVERHEAD CODE (SOCOD). This code indicates which of four methods (A, B, C, or D) is used to calculate labor overhead this-level in the associated Item Master B-records. The cost technique code in associated Item Master B-records must be R if this code is used. Type in the current and/or standard simulation values.

A description of each of these four labor overhead codes and its respective method follows. In these formulas, detailed time values (TBC=M for minutes) are converted from minutes to equivalent hours before calculations are performed.

OVERHEAD RATE OR PERCENT (COVER or SOVER). This field shows the labor overhead rate or percent used in the labor overhead calculation (see display AMVX71 for these rates and percents). It is used in PDM costing formulas based on the labor overhead code (COCOD, SOCOD) you entered. Type in the current and/or standard simulation values.

Note: If you selected option 4 (Simulate Product Cost—Current) on the Costing menu, AMEM04, you can enter simulation data for current costing. If you selected option 5 (Simulate Product Cost—Standard), you can enter simulation data for standard costing. If you selected option 6 (Simulate Product Cost—Both), you can enter simulation data for both current and standard costing.

AMEJ76—Product Cost Simulation—Change by Facility (Review)

Use this display to review both the present values for the facility and the simulation values you entered on display AMEJ75. In addition, you can choose to enter the next facility ID for simulation, to end the program (F24), or to cancel simulation (F10).

This display appears when you type valid simulation values or you select F01 (Select Another Facility) on display AMEJ75.

```

DATE **/**/**          PRODUCT COST SIMULATION          REVIEW    AMEJ76  **
                        --CHANGE BY FACILITY--

FACILITY   DESCRIPTION
*****
                                CURRENT          STANDARD
MACHINE RATE          ** , *** . ***    ** , *** . ***
SIMULATION VALUE ENTERED ** , *** . ***    ** , *** . ***
RUN LABOR RATE        ** , *** . ***    ** , *** . ***
SIMULATION VALUE ENTERED ** , *** . ***    ** , *** . ***
SETUP LABOR RATE      ** , *** . ***    ** , *** . ***
SIMULATION VALUE ENTERED ** , *** . ***    ** , *** . ***
OVERHEAD CODE         *
SIMULATION CODE ENTERED *
OVERHEAD              ** , *** . ***    ** , *** . ***
SIMULATION VALUE ENTERED ** , *** . ***    ** , *** . ***

NEXT FACILITY
aaaa5

                                F10 CANCEL SIMULATION
                                F24 END OF JOB

```

What to do

- To change the simulation information shown for the facility you entered on display AMEJ74 or to simulate a change for another facility, type a facility ID in the FACILITY field and press **Enter**. Go to display AMEJ75.
- To run product costing simulation, use **F24**. PDM schedules the report for printing.

Function keys

F10 CANCEL SIMULATION cancels the job and causes the Costing menu (AMEM04) to appear.

F24 END OF JOB submits the Product Costing Simulation report to the job queue to be printed and causes the Costing menu (AMEM04) to appear again to allow you to enter simulated rates for this facility.

Fields

[?] appears next to a field name in the following field definitions to identify a field from which you can begin a master file search.

[Contents](#)

[Index](#)

The NEXT FACILITY field is optional. The remaining fields are informational only, and you use them to review the information you entered in them on display AMEJ75. See that display for descriptions of these fields.

NEXT FACILITY [?]. When you have completed review of the actual and the simulated values for the facility, you can type in the ID of the next facility whose rates you want to simulate changed.

AMEJ77—Product Cost Simulation—Change by Percent (Enter)

Use this display to simulate a percent change in material this level for a specific item class and/or in the rates (machine, labor, setup, or labor overhead) for all facilities.

This display appears when you select 3 (Change by Percent) on display AMEJ70.

This display allows you to enter item class (optional) and current and standard percent changes to material this-level for all items within that item class and percent changes for machine rate, run labor rate, setup labor rate, and overhead for all facilities.

```

DATE  **/**/**          PRODUCT COST SIMULATION          ENTER    AMEJ77  **
                        --CHANGE BY PERCENT--

TO SIMULATE COSTING BY ITEM CLASS
ENTER ITEM CLASS  A2
ENTER PERCENT CHANGE FOR          CURRENT  STANDARD
MATERIAL THIS LEVEL                nnn.nn  nnn.nn

TO SIMULATE COSTING BY FACILITY
ENTER PERCENT CHANGE FOR ALL FACILITIES CURRENT  STANDARD
MACHINE RATE                       nnn.nn  nnn.nn
RUN LABOR RATE                       nnn.nn  nnn.nn
SETUP LABOR RATE                     nnn.nn  nnn.nn
OVERHEAD                             nnn.nn  nnn.nn

F10 CANCEL SIMULATION
F19 RETURN TO SELECT
    
```

What to do

To simulate a percentage change in an item's material this-level or to simulate a percentage change in a facility's machine rate, run labor rate, setup labor rate, or overhead rate or percentage, type in the information requested. Press **Enter**. PDM schedules the report for printing.

Function keys

F10 CANCEL SIMULATION cancels the job and causes the Costing menu (AMEM04) to appear again.

F19 RETURN TO SELECT ignores any data you entered and causes display AMEJ70 to appear again.

Fields

To simulate costing by item class, the fields ENTER ITEM CLASS and ENTER PERCENT CHANGE FOR MATERIAL THIS LEVEL are required.

To simulate costing by facility, at least one percent change (Current and/or Standard) is required to be entered for **MACHINE RATE**, **RUN LABOR RATE**, **SETUP LABOR RATE**, or **OVERHEAD**.

If you selected option 4 (Simulate Product Cost—Current) on the Costing menu (AMEM06) you can enter current cost in the following fields. If you selected option 5 (Simulate Product Cost—Standard), you can enter standard cost in the following fields. If you selected option 6 (Simulate Product Cost—Both), you can enter both current and standard cost in the following fields.

TO SIMULATE COSTING BY ITEM CLASS.

ENTER ITEM CLASS (ITCLS). Required. Type in the code (user assigned) that identifies the class or grouping of items for which you want to simulate changes in material this-level. For example, the code ST might indicate all items made of steel.

If you type in asterisks (**) in this field, the percent change you enter below is applied to all item classes.

ENTER PERCENT CHANGE FOR MATERIAL THIS LEVEL (CURRENT and/or STANDARD). Required. Type in the simulated percentage change you want applied to all items having the item class you entered. For example, you might want to simulate the effect of a 10% increase in all items in your bill of materials that are made of steel.

TO SIMULATE COSTING BY FACILITY.

ENTER PERCENT CHANGE FOR ALL FACILITIES. Type in the percent change you want applied across all facilities in one or all of the following fields. For example, you could simulate an increase in the rate paid to those employees performing machining operations in all facilities by typing in the appropriate percentage in the **RUN LABOR RATE** field.

MACHINE RATE CURRENT and/or STANDARD (CMACH or SMACH). This rate, in cost per hour, is used with the run machine field (RUNMC), factored by the time basis code (TBCOD) of the associated routing, to calculate the run machine cost. PDM product costing also uses this value to calculate overhead content this-level in the associated Item Master B-records.

RUN LABOR RATE CURRENT and/or STANDARD (CRLAB or SRLAB). This rate, in cost per hour, is used with the run labor field (RUNLB), factored by the time basis code (TBCOD) of the associated routing, to calculate the standard run labor cost. PDM product costing also uses this value to calculate labor and labor overhead content this-level in the associated Item Master B-records. This field is not used in calculating run labor costs for routing operations with time basis code C (outside operation).

SETUP LABOR RATE CURRENT and/or STANDARD (CSLAB or SSLAB). This rate, in cost per hour, is used with the Setup Labor Time (SULHR) and Setup Crew Size (SUCSZ) fields of the associated routing to calculate the standard setup labor cost. PDM's product costing also uses this value to calculate labor and labor overhead content this-level in the associated Item Master B-records.

OVERHEAD CURRENT and/or STANDARD (COCOD or SOCOD). This field shows the labor overhead rate or percent used in the labor overhead calculation

[Contents](#)

[Index](#)

(see display AMVX71 for these rate and percents). It is used in PDM's costing formulas based on the labor overhead code (SOCOD) you entered.

Note: The five percent fields are all signed fields. After typing in the field value, remember to press either **FIELD EXIT** or **FIELD +** if you entered a positive value or **FIELD -** if you entered a negative value. These percentages adjust the existing facility information for the desired simulation effect. For example, to simulate an increase of 12.5%, enter 12.5. To simulate a decrease of 12.5%, enter 12.5-.

[Contents](#)

[Index](#)

Option 7. Item Cost Percent Change (AMEM04)

Use this option anytime you want to change the material costs of all items or all items within a specific item class.

What information you need: The item class whose material you want to change and the percent change amount you want to use.

What reports are printed: Item Cost Percent Change Audit (AMET5).

What forms you need: None.

AMET50—Item Cost Percent Change—Percent Change of Material by Item Class (Chang%)

Use this display to change the material costs of all items with a specific item class (ITCLS).

This display appears when you select option 7 (Item Cost Percent Change) on the Costing menu (AMEM04).

This display allows you to change the material costs of all items or all items in a specific item class. You can enter the item class, select current costs, standard costs or both, and enter the percent change to be applied to the material this level field of those items selected. Only one item class (the last one you entered if you entered more than one) is processed at a time.

```

DATE **/**/**          ITEM COST PERCENT CHANGE          CHANG%          AMET50  **
-- PERCENT CHANGE OF MATERIAL BY ITEM CLASS --

ENTER--
ITEM CLASS  aaA4
% CHANGE    nnn.nn
COST TYPE   n

SELECT ONE OF THESE COST TYPES
1 CURRENT
2 STANDARD
3 BOTH

F24 CANCEL

```

What to do

To change the material costs of items in an item class, type in the information requested and press **Enter**. PDM schedules the report for printing.

Function keys

F24 CANCEL ignores the data you just entered and causes the Costing menu (AMEM04) to appear.

Fields

All the fields on this display are required.

ITEM CLASS. Type in the item class whose percent of material costs is to be changed. The percent change you type in is applied to item classes 3, 4, and 9 only.

[Contents](#)

[Index](#)

% CHANGE. Type in the percent change amount to be applied to the material costs by item class.

COST TYPE. Type in one of the following cost types to be changed:

- 1 Current
- 2 Standard
- 3 Both.

Option 8. Change L/O Costing Table (AMEM04)

Use this option anytime you want to change the labor rates, the labor overhead rates, or the percentages in the Labor/Overhead Table.

This option allows you to change labor rates or labor overhead rate/percentages in the Labor/Overhead Costing Table, which is stored in the System Control file. The table is used only if product costing was selected during application tailoring. For items with a Cost Technique Code of T, product costing uses the Labor/Overhead Table (Costing) whereas simulated product costing uses the Labor/Overhead Table (Simulation). See Chapter 2, "Managing Product Data Management" for more detail.

What information you need: The new labor rates or percentages.

What reports are printed: None.

What forms you need: Labor/Overhead Table—Change Entry (PM-13).

AMVX71—Labor/Overhead Table (Change)

Use this display to initially build and later to review and change labor and labor overhead rates and labor overhead percentages in the Labor/Overhead Table.

Note: The values in this table are used in product costing when CTECH = T in the item's Item Master B-record to determine the labor and labor overhead cost for a particular manufacturing level.

This display appears when you select options 8 or 9 on the Costing menu (AMEM04).

You can update the labor rates and the labor overhead rates or percentages. Labor overhead percentages are indicated by entering a minus value. Valid codes are A through Z and 0 through 9. Any of the codes can be changed. You cannot use duplicate labor codes or duplicate labor overhead codes for values A through Z or 0 through 9. However, a labor rate code can be the same as a labor overhead rate code. Blank codes are not valid as a labor/overhead table code (SRLC, CRLC, SOHC, or COHC) in the Item Master B-records. The code you place in the Item Master B-record for items whose cost technique code (CTECH) is T corresponds to the rate for that code in the Labor/Overhead Table or the simulation Labor/Overhead Table.

```

DATE **/**/**          LABOR/OVERHEAD TABLE          CHANGE      AMVX71  **
COSTING TABLE        CODE      LABOR          CODE      OVERHEAD *
                        RATE          RATE/PERCENT
                        A      nnnnn . nnn    A      nnnnn . nnn
                        A      nnnnn . nnn    A      nnnnn . nnn
                        A      nnnnn . nnn    A      nnnnn . nnn
                        A      nnnnn . nnn    A      nnnnn . nnn
                        A      nnnnn . nnn    A      nnnnn . nnn
                        A      nnnnn . nnn    A      nnnnn . nnn
                        A      nnnnn . nnn    A      nnnnn . nnn
                        A      nnnnn . nnn    A      nnnnn . nnn
                        A      nnnnn . nnn    A      nnnnn . nnn
                        A      nnnnn . nnn    A      nnnnn . nnn
                        A      nnnnn . nnn    A      nnnnn . nnn
LAST MAINTAINED:      **/**/**          **/**/**
* POSITIVE VALUE INDICATES RATE
  NEGATIVE VALUE INDICATES PERCENT
                        F18 REFRESH SCREEN
                        F24 END OF JOB

```

What to do

To build or change the Labor/Overhead Table, type in the code and rate or percentage. Press **Enter**.

Function keys

F18 REFRESH SCREEN erases any data you may have typed in and, if you have not pressed **Enter**, shows AMVX71 as it first appeared.

If you have pressed **Enter**, F18 refreshes the display with the new table values.

F24 END OF JOB ignores any data you typed in and causes the Costing menu (AMEM04) to appear again.

Use F24 to return to the Costing Menu (AMEM04) after you have updated the Labor/Overhead Table.

Fields

CODE. You can make changes to any of the labor rate code data fields. Valid codes are A-Z and 0-9.

LABOR RATE. This rate, in cost per hour, is used with the **Standard Labor Hour** field (LABHR) in the Item Master B-record to calculate run labor cost.

CODE. You can make changes to any of the overhead rate/percent code data fields. Valid codes are A-Z and 0-9.

OVERHEAD RATE/PERCENT. A blank in the sign field to the right of the **RATE/PERCENT** field indicates rate, and a negative symbol (-) indicates percent. The Overhead Rate/Percent fields are signed fields. After typing in the field value, remember to press either **FIELD EXIT** or **FIELD+** if you entered a positive value or **FIELD -** if you entered a negative value.

LAST MAINTAINED. This field shows the date when the Costing Table or Simulation Table was last changed.

Option 9. Change L/O Simulation Costing Table (AMEM04)

Use this option anytime you want to change the labor rates, the labor overhead rates, or the percentages in the Labor/Overhead Simulation Table.

This option allows you to change labor rates or labor overhead rate/percentages in the Labor/Overhead Simulation Table, which is stored in the System Control file. The table is used only if product costing was selected during application tailoring. For items with a Cost Technique Code of T, product costing uses the Labor/Overhead Table (Costing) whereas simulated product costing uses the Labor/Overhead Table (Simulation). See Chapter 2, "Managing Product Data Management" for more detail.

What information you need: The new labor rates or percentages.

What reports are printed: None.

What forms you need: Labor/Overhead Table—Change Entry (PM-13).

AMVX71—Labor/Overhead Table (Change)

Use this display to initially build and later to review and change labor and labor overhead rates and labor overhead percentages in the Labor/Overhead Simulation Table.

Note: The values in this table are used in product costing when CTECH = T in the item's Item Master B-record to determine the labor and labor overhead cost for a particular manufacturing level.

This display appears when you select options 8 or 9 on the Costing menu (AMEM04).

If you selected option 9 (Change Labor/Overhead Simulation Costing Table), this display shows Simulation Table under the date. Any code, rates, or percents entered are put into the Simulation Labor/Overhead Table to be used for simulated product costing.

DATE **/**/**	LABOR/OVERHEAD TABLE	CHANGE	AMVX71 **
SIMULATION TABLE	CODE	LABOR RATE	OVERHEAD * RATE/PERCENT
	A	nnnnn . nnn	A nnnnn . nnn
	A	nnnnn . nnn	A nnnnn . nnn
	A	nnnnn . nnn	A nnnnn . nnn
	A	nnnnn . nnn	A nnnnn . nnn
	A	nnnnn . nnn	A nnnnn . nnn
	A	nnnnn . nnn	A nnnnn . nnn
	A	nnnnn . nnn	A nnnnn . nnn
	A	nnnnn . nnn	A nnnnn . nnn
	A	nnnnn . nnn	A nnnnn . nnn
	A	nnnnn . nnn	A nnnnn . nnn
	A	nnnnn . nnn	A nnnnn . nnn
	A	nnnnn . nnn	A nnnnn . nnn
	A	nnnnn . nnn	A nnnnn . nnn
LAST MAINTAINED:	**/**/**	**/**/**	**/**/**
		* POSITIVE VALUE INDICATES RATE NEGATIVE VALUE INDICATES PERCENT	
		F18 REFRESH SCREEN F24 END OF JOB	

For information about this display, see “AMVX71—Labor/Overhead Table (Change)”.

Option 10. Change P/O Costing Table (AMEM04)

Use this option anytime you want to change the purchase overhead codes or the percentages in the Purchase Overhead Table.

This option allows you to change purchase overhead codes or percentages, which is stored in the System Control file. The table is used only if product costing was selected during application tailoring. See Chapter 2, "Managing Product Data Management" for more detail.

What information you need: The new purchase codes or percentages.

What reports are printed: None.

What forms you need: Purchase Overhead Table—Change Entry (PM-16).

Use F24 to return to the Costing Menu (AMEM04) after you have updated the Purchase Overhead Table by pressing **Enter**.

Fields

CODE. You can make changes to any of the purchase code fields. Valid codes are A-Z and 0-9.

OVERHEAD PERCENT. This percentage is used with the material cost of purchase items (CMAT, SMAT) in the Item Master B-record to calculate purchase overhead cost.

LAST MAINTAINED. This field shows the date when the Costing Table or Simulation Table was last changed.

LAST COSTED CUR or STD. These fields show the date when the last current or standard costing was completed. If option 11 (Change Purchase Overhead Simulation Costing Table) was selected, this display shows Last Simulated for the dates.

Option 11. Change P/O Simulation Costing Table (AMEM04)

Use this option anytime you want to change the purchase overhead codes or the percentages in the Purchase Overhead Simulation Table.

This option allows you to change purchase overhead codes or percentages, which is stored in the System Control file. The table is used only if product costing was selected during application tailoring. See Chapter 2, "Managing Product Data Management" for more detail.

What information you need: The new purchase codes or percentages.

What reports are printed: None.

What forms you need: Purchase Overhead Table—Change Entry (PM-16).

AMVX72—Purchase Overhead Table (Change)

Use this display initially to build and later to review and change purchase overhead codes and percentages in the Purchase Overhead Table.

Note: The values in this table are used in product costing for purchased parts or raw materials with item type 3, 4, or 9 to determine the purchase overhead cost for a particular manufacturing level.

This display appears when you select option 10 or 11 on the Costing menu (AMEM04).

If you selected option 11 (Change Purchase Overhead Simulation Costing Table), this display shows Simulation Table under the date. Any codes or percentages entered are put into the Simulation Purchase Overhead Table to be used for simulated product costing.

```

DATE **/**/**              PURCHASE OVERHEAD TABLE              CHANGE      AMVX72  **
SIMULATION TABLE          CODE              OVERHEAD      CODE              OVERHEAD
                              PERCENT                               PERCENT

A                            nnn.nn        A               nnn.nn
A                            nnn.nn        A               nnn.nn
A                            nnn.nn        A               nnn.nn
A                            nnn.nn        A               nnn.nn
A                            nnn.nn        A               nnn.nn
A                            nnn.nn        A               nnn.nn
A                            nnn.nn        A               nnn.nn
A                            nnn.nn        A               nnn.nn
A                            nnn.nn        A               nnn.nn
A                            nnn.nn        A               nnn.nn
A                            nnn.nn        A               nnn.nn

LAST MAINTAINED:  **/**/**
*****          **/**/**
*** **/**/**

F18 REFRESH SCREEN
F24 END OF JOB

```

For information about this display, see AMVX72—Purchase Overhead Table (Change) on page 32.

Option 12. Roll Current to Standard Costs (AMEM04)

Use this option anytime you want to roll costs from current to standard. Normally, this function is used in preparation for starting a new year. A confirmation display appears before any action is taken.

The costs that are rolled include:

- This-Level and Lower-Level cost fields in the Item Master B-record
- Labor and Overhead codes in the Item Master B-record
- Cost status code from the Item Master B-record
- Date of last maintenance for the cost fields in the Item Master B-record
- Work center labor/overhead rates and codes in the Production Facility Master
- Date of last cost generation and the type of generation in the Item Master B-record
- Yields in the Routing and Item Master file

In addition, the Recost flag will be set on the following conditions:

- If the Recost flag is set to recost current (C), set the Recost flag to both (B)
- If the Recost flag is set to a new item needs current costs recalculated (O), set the flag to both (N).

What information you need: None.

What reports are printed: None.

What forms you need: None.

AME4601—Roll Current to Standard Costs (Confirm)

Use this display to confirm that you want to roll costs from current to standard.

```
Date **/**/**          Product Costing          AME4601 **
                        Roll current to standard costs

Press Enter to confirm that you want current
costs rolled over to standard costs.

F24=Cancel
```

What to do

Press **Enter** to confirm that you want to roll costs from current to standard.

Function keys

F24=Cancel causes the Costing menu (AMEM04) to appear again. The costs are not rolled.

Chapter 6. File Maintenance

When you select option 4 on the Main Menu (AMEM00) the File Maintenance menu (AMEM05) appears. This menu allows you to add, change, or delete information in the master files.

Option 1. Item Master (AMEM05).....	6-4
Option 2. Product Structure (AMEM05).....	6-28
Option 3. Production Facility (AMEM05)	6-73
Option 4. Routing (AMEM05)	6-100
Option 5. Item Base Price (AMEM05)	6-157
Option 6. Item Foreign Language Description (AMEM05).....	6-162
Option 7. Code Files (AMEM05).....	6-167
Option 8. Offline Maintenance (AMEM05).....	6-180
Option 9. PDM Control File Maintenance (AMEM05).....	6-190

```

AMEM05                                Product Data Management          *****
                                File Maintenance

Type option or command; press Enter.

    1. Item Master
    2. Product Structure
    3. Production Facility
    4. Routing
    5. Item Base Price
    6. Item Foreign Language Descriptions
    7. Code Files >>
    8. Offline Maintenance >>
    9. PDM Control File Maintenance

==> _____

F3=Exit      F4=Prompt    F9=Retrieve   F10=Actions
F11=Job status  F12=Return   F22=Messages
    
```

Option 1. Item Master. Use this option to do file maintenance on the Item Master file.

Option 2. Product Structure. Use this option to do file maintenance on the Product Structure.

Option 3. Production Facility. Use this option to do file maintenance on the Production Facility file.

Option 4. Routing. Use this option to do file maintenance on the Routing and Routing Description files.

Option 5. Item Base Price. Use this option to add, change, or delete information about the base price, effective dates, and pricing units of measure for items. This option takes you to a list of the base prices currently set up for items.

Option 6. Item Foreign Language Descriptions. Use this option to add, change, or delete foreign language versions of item descriptions. This option takes you to a list of the item foreign language descriptions currently created by your company.

Option 7. Code Files. Use this option to add, change, or delete the code values your company uses for certain data fields. This option takes you to the Code File Maintenance menu. The fields for which you define code values appear as options on the Code File Maintenance menu.

Option 8. Offline Maintenance. Use this option to perform offline file maintenance for the Item Master, Product Structure, Production Facility, and Routing files.

Option 9. PDM Control File Maintenance. Use this option to perform the maintenance for the data in the PDM Control file.

Most of the tasks in this option also can be executed in batch jobs outside this menu. See Appendix D, “Automated job submission for PDM” for more information on using the automated job submission function.

Overview

File maintenance for the Item Master file, Production Facility file, and Item Foreign Language Description file is online. Once the data is entered, the files are updated immediately. The other three files, Product Structure, Routing, and Routing Description, are maintained with online entry/edit but updated in batch mode. (Routing Description file maintenance does not have an option on the File Maintenance menu. It is maintained through Routing file maintenance.)

You can add, change, or delete data in any of the master files shown on the menu.

The Production Facility, Routing, and Routing Description files are optional files chosen during application tailoring. Also, during application tailoring, you choose whether you want an edit list to print for the Item Master and the Production Facility files when they are maintained. However, file maintenance to the Product Structure, Routing, and Routing Description files always causes an edit list to print when the files are maintained. The edit list can be used to verify that the changes made were correct and can be used as an audit trail to track down when and what changes were made to the files. Because certain file maintenance transactions can generate multiple add/change/delete transactions, you get two lists for Product Structure, Routing, and Routing Description file maintenance. One shows the transactions as entered and the other shows the generated add, change, and delete transactions.

If Production Facility and Routing files were not selected during application tailoring and you select option 3 or 4, your request is cancelled and the Main Menu (AMEM00) appears again.

Maintenance data entry forms are in Chapter 9, "Forms" for your use when maintaining files.

Conflicts

Be aware of the conflicts described for each type of file maintenance. Performance depends on how well you manage file maintenance. When a conflict exists, the master file maintenance is canceled in the job queue before it starts; however, once maintenance starts it is not canceled. Conflicts between file maintenance batch update for the Product Structure file and the Routing file cause the batch update programs to be put in the job queue.

Option 1. Item Master (AMEM05)

Use this option anytime you want to add a new item to the Item Master file, change or delete an item already in the file, or set defaults for a file maintenance session.

Notes:

1. You can add, change, or delete costing information in the Item Master file B-record only if PDM product costing was selected during application tailoring or if the full version of Material Requirements Planning (MRP) is installed and interfacing with PDM.
2. You cannot maintain the Item Master file if product costing is running.

What information you need:

- Item number
- Item description
- Stocking unit of measure
- Item type code
- Standard batch quantity.

What reports are printed: Item Master File Maintenance (AMVT0).

What forms you need:

- Item Master File Maintenance—General Information—PM-01
- Item Master File Maintenance—Additional Information—PM-02
- Item Master File Maintenance—Costing Information—PM-03
- Item Master File Maintenance—Purchasing Information—PM-04.

The Item Master file contains at least two records, the A-record and A-record extension for each unique item number. The A-record contains required fields and has general item information.

The Item Master file contains a B-record for each item if any one of the following conditions is true:

- Product costing was selected during application tailoring.
- The full version of Material Requirements Planning (MRP) is installed and interfacing.
- Master Production Schedule Planning (MPSP) is installed and interfacing.

The B-record contains optional fields and has costing information.

The Item Master file has a C-record for each purchased item if Purchasing is installed and interfacing. The C-record contains optional fields and purchasing information.

Notes:

1. When you delete an item, the A-record, A-record extension, B-record, and C-record for that item are deleted along with the Item Base Price file record. Also, for any item you delete, you automatically delete the Item Foreign Language file records that have the same item number as the deleted item and the item base price.
2. When you want to delete an Item Master record, the application checks to make sure that no active balance records, open purchase orders, manufacturing orders, planned orders, and customer orders exist for the item. If they exist or if the item is a component of a higher level item, you cannot delete the item.

You must also delete the product structure and routing records for every item you want to delete.

3. If MPSP is installed and interfacing, and the item is a production family or an end item assigned to a production family (family member), you must use MPSP production family file maintenance to delete the family or member from the Production Family Relationship file before you can delete the item from the Item Master file.
4. If MRP or MPSP is installed and interfacing, and you want to delete an item that is coded as a master level item or master scheduled item, you must first change the Master Level Item Code to blank and the Order Policy Code to B or C. This automatically removes all planned orders and requirements for the item after the next MRP or MPSP planning run. After the next MRP or MPSP planning run is complete, delete the item using Item Master file maintenance.
5. When you add a new record to the Item Master file and Inventory Management is installed and interfacing with Product Data Management, you must also add an item balance record to the Item Balance file, as described in the *Inventory Management User's Guide*.
6. When you add a new record to the Item Master file and Purchasing is installed and interfacing with Product Data Management, you must also add an Item Master C-record for each purchased item. The C-record is optional for any other item.

AMVT01—Item Master File Maintenance (Select)

Use this display to select the type of Item Master file maintenance you want to do and to enter the number of the item you want to maintain.

This display appears when you select option 1 on the IM File Maintenance menu (AMIM70), or option 1 on the Purchasing File Maintenance menu (AM6M60), or when you press **Enter** or **F19** (Return to Select) on any of the following displays: AMVT02, AMVT03, AMVT04, AMVT05, and AMVT06.

```

DATE **/**/**          ITEM MASTER FILE MAINTENANCE      SELECT      AMVT01  **

                               ENTER-
                               ITEM      aaaaaaaaaaaaA15
                               ACTION   A
                               DISPLAY  A

SELECT ACTION-
A ADD
C CHANGE
D DELETE
S SET DEFAULTS FOR SESSION

SELECT DISPLAY TO APPEAR FIRST-

1 ALL DISPLAYS (IN SEQUENCE)

2 GENERAL INFORMATION
3 ADDITIONAL INFORMATION
4 COSTING INFORMATION
5 PURCHASING INFORMATION

                               F23 STATUS
                               F24 END OF JOB
    
```

What to do

Depending on the action code and display code you selected, pressing **Enter** causes one of the following displays to appear:

Action	Display Code	Display
Add	1. All displays in sequence	AMVT02
	2. General Information	AMVT02
Change	1. All displays in sequence	AMVT02
	2. General Information	AMVT02
	3. Additional Information	AMVT03
	4. Costing Information	AMVT04
	5. Purchasing Information	AMVT05
Delete	1. All displays in sequence	AMVT02
	2. General Information	AMVT02
	3. Additional Information	AMVT03
	4. Costing Information	AMVT04
	5. Purchasing Information	AMVT05

Action	Display Code	Display
Set Defaults	1. All displays in sequence	AMVT02
	2. General Information	AMVT02
	3. Additional Information	AMVT03
	4. Costing Information	AMVT04
	5. Purchasing Information	AMVT05

Function keys

F23 STATUS ignores the information you typed in and causes display AMVT06 to appear.

F24 END OF JOB ignores the information you typed in and causes the menu to appear again. The Item Master File Maintenance Report is printed.

Fields

[?] appears next to a field name in the following field definitions to identify a field from which you can begin a master file search.

ITEM (ITNBR) [?]. Required except when you want to set defaults for a session. For all actions except S, type in the number of the item you want to add or maintain.

For action A, if MMS is interfacing, the item number must be unique. It must not already exist in MMS as an MRO item.

For action S, the item number is optional. Type in the item number if you want to use the item's existing information to set defaults for this session. Leave the **ITEM** field blank to set new defaults for this session.

SELECT ACTION. Required except when you want to set defaults for a session. Select and type in one of the following action codes:

- A** Add
- C** Change
- D** Delete
- S** Set defaults for session.

Notes:

1. You cannot delete an item from the Item Master file if any of the following conditions exist:
 - The item has active balance records, open purchase orders, open manufacturing orders, planned orders, or open customer orders.
 - The item is a component of a higher-level item.
 - The item has product structure and routing record.

In addition, you cannot delete an item from the Item Master file if Master Production Schedule Planning (MPSP) is installed and interfacing, and if any of the following conditions exist:

- The item is assigned to a production family.
- The item is a production family with members assigned to it.

2. Use action code S to set defaults for a file maintenance session. If you want to copy an existing item's information to use as defaults, type in that item's number in the **ITEM** field. If you want to create new defaults, leave the **ITEM** field blank. The defaults you set override any existing defaults and are in effect only for the current file maintenance session.

SELECT DISPLAY TO APPEAR FIRST. Required except when you want to set defaults for a session. Type in one of the following display codes. If you are adding an item (action A), the only valid display codes are 1 or 2. All display codes are valid for changing an item (action C), deleting an item (action D), and setting defaults for a file maintenance session (action S).

- 1 All Displays (In Sequence)
- 2 General Information
- 3 Additional Information
- 4 Costing Information
- 5 Purchasing Information.

Note: Display Code 4 is valid only if B-records are in the Item Master file; that is, if product costing was selected during Product Data Management (PDM) application tailoring or if Material Requirements Planning (MRP) is installed. Display Code 5 is valid only if C-records are in the Item Master file; that is, if Purchasing is installed.

AMVT02—Item Master File—General Information (Add/Change/Delete/Set Defaults)

Use this display to add, change, or delete general item information for the item number or to set defaults for general item information for this file maintenance session.

This display appears when you select action A (add), C (change), D (delete) or S (set defaults) and either option 1, All Displays (in sequence), or option 2, General Item Information (A-Record), on display AMVT01. It also appears when you select **F03 PREV DISPLAY** on display AMVT03.

```

DATE **/**/**                ITEM MASTER FILE                ADD                AMVT02  **
                                -GENERAL INFORMATION-
ITEM AND                                INVENTORY
DESCRIPTION aaaaaaaaaaaaaaaaaaaaaaaaaA30                ENGR DRAWING aaaaaaaaaaaaaA15

STOCKING UNIT OF MEASURE                A2                ITEM TYPE CODE                n
UNIT COST DEFAULT nnnnnnnnnnnn.nnnnnnnn                ITEM CLASS                aaA4
UNIT WEIGHT                nnnn.nnnn                WEIGHT UNIT OF MEASURE                A2
ORDER UNIT OF MEASURE CLASS                nn                WAREHOUSE STOCK LOCATION                aaaaaA7
ALTERNATE ITEM nnnnnnnnnnnnnnnnnnnnnnnn                VENDOR-PRIMARY                aaaaA6
DEPARTMENT                nnnn                ITEM ACCOUNTING CLASS                aA3
CARRYING RATE                .nnnn                VALUE CLASS                A
STD SETUP COST/LOT nnnnnnnnnnnn.nnnnnnnn                PACKING CODE                A2
STD BATCH QTY                nnnnnnnn.nnnn                INVENTORY CODE                n
BILL OF LADING COMMODITY CODE aaaaaaaA8                QC CONTROL                n
PURCHASE TAX INDICATOR                aA3                SHELF LIFE                nnnn
SALES TAX INDICATOR                aA3                BATCH/LOT CTL                n
PRINT ON SALES ANALYSIS                n                INSPECT ON RCPT                n
ITEM TAX CLASS                aaaaaaaaaaaaaA15                DISCRETE ALLOC                n
DATE LAST MAINTAINED                *****                KIT EXTERNAL DOCUMENT PRINT OPT                n
LAST MAINTAINED BY                *****                F02 NEXT DISPLAY

                                                F15 NOTE TASKS
                                                F18 REFRESH
                                                F19 RETURN TO SELECT

```

What to do

- If you selected option 1, All Displays (in Sequence), on display AMVT01, press **Enter** to work with additional information for the item. Go to display (AMVT03).
- If you selected option 2, General Information or used **F03** on display AMVT03 or if there are no B-records in the Item Master file, press **Enter** to update the Item Master File accordingly. Go back to the Item Master Maintenance (Select) display (AMVT01).

Note: The Item Master file is updated with information maintained on any of the following displays: AMVT02, AMVT03, AMVT04, or AMVT05.

Function keys

F02 NEXT DISPLAY causes display AMVT03 to appear.

F15 NOTE TASKS allows you to access the Note Tasks function. If a note exists, an icon, @, appears in the upper right corner of the display. For more information on this function, see the *Planning and Installing Infor ERP XA* book.

F18 REFRESH erases any information you typed in and shows you AMVT02 as it first appeared.

F19 RETURN TO SELECT ignores the information you just entered and causes display AMVT01 to appear again.

Fields

[?] appears next to a field name in the following field definitions to identify a field from which you can begin a master file search.

When you use enter a question mark in one of the fields listed below, you can search, select, or add a code value. To change or delete a code value, use the Code Files option on the file maintenance menu for this application. This applies to the following fields:

BILL OF LADING COMMODITY CODE
ITEM CLASS
ORDER UNIT OF MEASURE CLASS
STOCKING UNIT OF MEASURE
WEIGHT UNIT OF MEASURE

In Add, Change or Set Defaults mode, **DESCRIPTION**, **STOCKING UNIT OF MEASURE**, and **ITEM TYPE CODE**, are required, and in Delete mode, all fields are informational.

Note: Do not enter negative values in numeric fields.

The **UNIT COST DEFAULT** and **STD SETUP COST/LOT** fields do not appear on the display if you do not have the proper security level for maintaining Item Master cost fields.

ITEM (ITNBR). This field shows the number of the item you entered on display AMVT01. If KBC is interfacing and this is a configured item, the word CONFIGURED appears beside the item number.

INVENTORY DESCRIPTION. This field appears below the display ID and has no heading. This field shows one of four different categories depending on the inventory code:

INVENTORY	If the item is an inventory item
MISCELLANEOUS	If the item is a miscellaneous item
SERVICE	If the item is a service item
UNSTOCKED	If the item is not stocked (no Item Balance file record).

Refer to the *Material Requirements Planning User's Guide* for more information on the following fields:

VENDOR-PRIMARY
CARRYING RATE
STD SETUP COST/LOT

DESCRIPTION (ITDSC). Type in the description of the item that is to appear on inquiries and reports.

ENGR DRAWING (Engineering Drawing) (ENGNO). Type in the number identifying the drawing of an end product or item.

STOCKING UNIT OF MEASURE (UNMSR) [?]. Type in the code (user assigned) that defines the measurement basis of onhand quantity and issue quantity for this item; for example, EA (each), KG (kilogram), or CM (centimeter).

ITEM TYPE CODE (ITYP). Code that best describes the type of item:

0	Phantom
1	Assembly or subassembly
2	Fabricated item
3	Raw material
4	Purchased item
9	User option (Special)
F	Feature
K	Kit

Notes:

1. If MPSP is installed and interfacing, and the Master Scheduled Item (MSI) code is P, the only valid item type code is 0 (Phantom). See “AMVT03—Item Master File—Additional Information (Add/Change/Delete/Set Defaults)” for a definition of the master scheduled item codes.
2. Item type code 9 (user option) may have purchase, purchase overhead (calculated), labor, labor overhead, and components. If you select item type code 9, labor and labor overhead (this level) are calculated from the routing (cost technique code = R) or from the Labor/Overhead Table (cost technique code = T). Or, if the cost technique code is blank, you must manually enter purchase, labor, and labor overhead costs. PDM does not roll up lower-level costs when the item type is 9 and you must always manually enter purchase cost. Purchase overhead is calculated based on the Purchase Overhead Table code and user-entered purchase content. The lower-level cost fields of an item type 9 are forced to zero, even if the item has components.
3. A kit must have an inventory code of 4 (unstocked item).

UNIT COST DEFAULT (UCDEF). Type in the cost to your company for one unit of the item. Inventory Management (IM) and Customer Order Management (COM) use this field only if the cost field (standard, average, or last) is blank in the Item Balance file. If PDM product costing was selected during application tailoring and IM is installed and interfacing, IM can optionally (during period-end close) change the value in this field to the value of the standard unit cost contained in the Item Master B-record. Forecasting (FCST), if installed and interfacing, can use this field to cost forecast/projection quantities.

ITEM CLASS (ITCLS) [?]. Type in the code (user-assigned) that describes the classification to which this item belongs; for example, ST might be used to code all items made of steel.

Note: Uses of the item class code include the following:

- FCST, if installed and interfacing, can use this field to classify items that have been coded as master level items (MLI codes M or S).
- Sales Analysis can be performed using item class.
- PDM product costing allows percentage change of purchase content (cost) for all items having a specific item class.
- Several PDM and IM reports allow limits to be set using item class and can also be sequenced using item class.

- MPA, if installed and interfacing, can use this field to group item measurement data.

UNIT WEIGHT (WEGHT). Type in the weight of one unit of the item. This field can be used by both COM and MRP (if installed and interfacing).

WEIGHT UNIT OF MEASURE (XBCQCD) [?]. The unit of measure for the weight of this item.

ORDER UNIT OF MEASURE CLASS (XBC8CD) [?]. A code defined by your company used to group or classify items with functionally equivalent units of measure.

WAREHOUSE STOCK LOCATION (WHS LC). Type in the code (user assigned) indicating the location of the item in the warehouse.

Note: IM transaction processing uses the stock location defined in the Item Balance file.

ALTERNATE ITEM (XOEMNS). A user-defined identifier for this item used for informational purposes. For example, it can be a UPC number or an OEM number. It may be sent on EDI documents using Electronic Commerce (EC).

VENDOR-PRIMARY (VNDNR) [?]. Type in the number of the primary supplier of the item. If MRP is installed and interfacing, and items are to be printed on MRP's Purchase Planning report, this field cannot be blank. If Accounts Payable or Purchasing is installed, this field is edited against the Vendor Master file and a warning message is issued if the Vendor Master record does not exist.

DEPARTMENT (DPTNO). Type in the department number for this item. This field is informational only.

ITEM ACCOUNTING CLASS (ITAC). Class, defined by your company, to group or classify items for accounting purposes.

CARRYING RATE (Inventory Carrying Rate) (CARRY). Type in the value used by MRP and MPSP (if installed and interfacing) in lot sizing the planned orders when the order policy code for this item is F or I. This value is expressed as a percentage of the item cost-to-carry inventory for one year and is used as an override to the standard carrying rate entered during IM application tailoring. This field is needed only for items with an exceptional (nonstandard) carrying rate.

VALUE CLASS (VALUC). Type in the user-assigned code that identifies the importance of the item. For example, the classes may be A, B, or C. FCST, if installed and interfacing, can use this field to classify items that have been coded as master level items (MLI codes M or S).

STD SETUP COST/LOT (Standard Setup Cost per Lot) (STDSU). Type in the total standard cost of setting up a production run for this item per lot. This field is used by IM's economic order quantity calculation and the lot sizing formula in MRP and MPSP, if installed and interfacing.

PACKING CODE (PACKC). Type in the appropriate Interstate Commerce Commission Packing Code for this item.

STD BATCH QTY (Standard Batch Quantity) (SBQTY). Type in the quantity that makes up a batch of this parent item. The quantity of each component in the parent

item's product structure expresses the quantity required to make a standard batch quantity of the parent item. This quantity can be based on a capacity constraint (such as vessel size), an expected yield, or a production goal. It can also serve as a multiplier to improve the level of precision required for components which are used in very small quantities compared to one unit of the end-item. If a quantity greater than one is entered, the component usage quantities are relative to this number.

For example, if a parent item is produced in batches of five gallons, the quantity requirements for components (quantity per) are based on producing five gallons of the parent instead of one gallon. MPSP can use this field to calculate the quantities for resource profiles. Standard batch quantity can provide the basis for a bill of material for an item with a quantity other than one. The default is 1.

INVENTORY CODE (INVFG). Type one of the following codes to classify this item in inventory:

- 1 Inventory item
- 2 Miscellaneous item
- 3 Service item
- 4 Unstocked item (valid only for item type code = K).

BILL LADING COMMODITY CODE (XBFOCD) [?]. A code defined by your company that groups or classifies items for a bill of lading. Different types of products can be grouped by commodity code.

QC CONTROL (QCTYP). Type a number that shows if this item requires quality control inspection.

- 1 The item requires quality control inspection. The **SHELF LIFE** field cannot be zero and the **BATCH/LOT CONTROL** field must be 1.
- 0 The item does not require quality control inspection. The **SHELF LIFE** field must be zero and the **BATCH/LOT CONTROL** field can be either 1 or 0.

PURCHASE TAX INDICATOR (PTAXI) [?]. Type in the user-defined code to classify the item for taxing during Purchasing and Accounts Payable activity.

SHELF LIFE (Shelf Life in Days) (QCDAY). If shelf life is required, type in a number of days from 1 to 9999 that represents the shelf life for this item. At the end of the number of days shown, this item needs to be inspected again. If the **QC CONTROL** field is 0, the **SHELF LIFE** field must be 0.

SALES TAX INDICATOR (STAXI) [?]. Type in the user-defined code to classify the item for taxing during Customer Order Management and Accounts Receivable activity.

BATCH/LOT CONTROL (Batch/Lot Control) (BLCF). Type in a code that indicates whether this item requires batch/lot control. The valid codes are:

- 1 The item requires batch or lot control.
- 0 The item does not require batch or lot control.

Note: You must enter 1 if KBC is interfacing and this item is a configured item.

PRINT ON SALES ANALYSIS (SAFLG). A code that indicates if information about this item is printed on the Sales Analysis reports.

- 1** The information is printed.
- 0** The information is not printed.

INSPECT ON RECEIPT (Inspect on Receipt) (INTYP). Type in one of these codes to indicate whether this item needs to be inspected before it is received to stock:

- 1** The item requires inspection.
- 0** The item does not require inspection.

ITEM TAX CLASS. The tax classification of an item that allows you to group items for tax purposes and tax code. It can apply to one or many items. Appears only if IFM is installed and interfacing.

DISCRETE ALLOCATION (ALLOC). Type in one of these codes to indicate whether this item can be allocated to manufacturing or customer orders:

- 1** The item can be allocated to manufacturing or customer orders.
- 0** The item cannot be allocated to manufacturing or customer orders.

DATE LAST MAINTAINED (MDATE). This field shows the date this Item Master record was last maintained. This field appears on Change, Delete and Set Defaults displays.

KIT EXTERNAL DOCUMENT PRINT OPTION (XIQST). A code that indicates whether an external document is printed for the components of a kit. An external kit document for the parent is always printed.

- 1** An external document for the kit components is printed.
- 0** No external document for the kit components is printed.

LAST MAINTAINED BY (XBAHVN). The user ID of the person who last maintained the Item Master record for this item. This field appears on Change, Delete and Set Defaults displays.

AMVT03—Item Master File—Additional Information (Add/Change/Delete/Set Defaults)

Use this display to add, change, or delete pricing information for the item number or to set defaults for pricing information for the item for this file maintenance session.

This display appears when you press **Enter** or select **F02 NEXT DISPLAY** on display AMVT02, when you select **F03 PREV DISPLAY** on display AMVT04, or when you select option 3 on display AMVT01.

```

DATE **/**/**          ITEM MASTER FILE          SET DEFAULTS  AMVT03  **
                        -ADDITIONAL INFORMATION-
ITEM *****          *****
DESCRIPTION *****

COMMISSION PERCENT          nnnn.nnn
BASE PRICE EFFECTIVE DATE  nn/nn/nn  BASE PRICE          nnn.nnn
ITEM PRICE CLASS          aaA4  ITEM PRICE UNIT OF MEASURE  A2
WARRANTY PERIOD          nnnnn
WARRANTY UNIT OF MEASURE  A2
SERIAL NUMBER REQUIRED      A
COUNTRY OF ORIGIN          aA3
ITEM SALES GROUP          aaaA5  SPECIFIC GRAVITY          nnnnn.nnnn
TAX COMMODITY CODE        aaaaaA8  TAX WEIGHT/UNIT          nnnnn.nnnn
SUPPLEMENTAL WEIGHT        nnnnn.nnnn  SUPPLEMENTAL WEIGHT U/M  A2
UNIT VOLUME                nnnn.nnn  VOLUME UNIT OF MEASURE  A2

DATE LAST MAINTAINED      **/**/**  LAST MAINTAINED BY      *****
                                                F02 NEXT DISPLAY
                                                F03 PREV DISPLAY
                                                F06 BASE PRICE MAINT
*** PRESS 'E N T E R' TO CONFIRM/DELETE THIS ITEM ***  F15 NOTE TASKS
                                                            F18 REFRESH
                                                            F19 RETURN TO SELECT

```

What to do

- If you selected option 1, All Displays (in sequence), on the display AMVT01 and there are costing records in the Item Master file, press **Enter** to work with costing information for the item. Go to display (AMVT04).
- If you selected option 3, Additional Information; if you used **F02** on display AMVT02 or **F03** on display AMVT04; or if there are no costing records in the Item Master file, press **Enter** to update the Item Master File accordingly. Go back to the Item Master File Maintenance (Select) display (AMVT01).
- To update pricing information for this item, use **F06**.

Note: **F06** appears on the display only if you are authorized to update pricing information.

The Item Master file is updated with information maintained on any of the following displays: AMVT02, AMVT03, AMVT04, or AMVT05.

Function keys

F02 NEXT DISPLAY causes display AMVT04 to appear. If there are no costing records in the Item Master file, this function key does not appear on the display.

F03 PREV DISPLAY causes display AMVT02 to appear.

F06 BASE PRICE MAINT causes display AMVB4EFR to appear. This function key appears in Change mode only.

F15 NOTE TASKS allows you to access the Note Tasks function. If a note exists, an icon, @, appears in the upper right corner of the display. For more information on this function, see the *Planning and Installing Infor ERP XA* book.

F18 REFRESH erases any information you typed in and shows you AMVT03 as it first appeared.

F19 RETURN TO SELECT ignores the information you just entered and causes display AMVT01 to appear again.

Fields

[?] appears next to a field name in the following field definitions to identify a field from which you can begin a master file search.

When you use enter a question mark in one of the fields listed below, you can search, select, or add a code value. To change or delete a code value, use the Code Files option on the file maintenance menu for this application. The fields this applies to are:

COUNTRY OF ORIGIN
SUPPLEMENTAL WEIGHT UNIT OF MEASURE
WARRANTY UNIT OF MEASURE
VOLUME UNIT OF MEASURE

If you are in Add, Change, or Set Defaults mode, **ITEM** and **DESCRIPTION** are informational. If you are in Delete mode, all fields are informational.

Note: Do not enter negative values in numeric fields.

ITEM. This field shows the number of the item you entered on display AMVT01.

Inventory Description. This field appears below the display ID and has no heading. This field shows one of four different categories depending on the inventory code:

INVENTORY	If the item is an inventory item
MISCELLANEOUS	If the item is a miscellaneous item
SERVICE	If the item is a service item
UNSTOCKED	If the item is not stocked (no Item Balance file record)

DESCRIPTION (ITDSC). This field shows the description of the item you entered on display AMVT02. This description appears on inquiries and reports.

COMMISSION PERCENT (XBAPPC). The percent of commission a sales representative can make on this item.

BASE PRICE EFFECTIVE DATE (BPEDT). The date that the base price is effective. This field is used by the Customer Order Management (COM) application. It appears only in Add mode.

BASE PRICE (BPRIC). The base price that is defined for this item. This field is used by the Customer Order Management (COM) application. It appears only in Add mode.

ITEM PRICE CLASS (BPRCL). A user-defined code to group items into categories for pricing. Items assigned the same item price code must have the same pricing unit of measure. This field is used by the Customer Order Management (COM) application. It appears only in Add mode.

ITEM PRICE UNIT OF MEASURE (BPRUM\$). The unit of measure assigned for the item price class. This field is used by the Customer Order Management (COM) application. It appears only in Add mode.

WARRANTY PERIOD (XLBNB). The length of warranty for this item.

WARRANTY UNIT OF MEASURE (XHJCD) [?]. The unit of measure for the warranty period for this item.

SERIAL NUMBER REQUIRED (XIPST). A code that indicates whether or not the item is tracked by serial number. This field is used by the Customer Order Management (COM) application.

- 1** The item is tracked by serial number.
- 0** The item is not tracked by serial number.

COUNTRY OF ORIGIN CODE (XCOC) [?]. A code defined by your company that indicates where the item is manufactured.

ITEM SALES GROUP (XADSB). The user-defined sales group that includes this item. This field is used by the Market Monitoring and Analysis (MMA) application.

SPECIFIC GRAVITY (XKMVA). A ratio of the density of a material to the density of water. (Water = 1gm/ml.)

TAX COMMODITY CODE (XAAB2) [?]. A code defined by your company that defines this item for tax purposes.

TAX WEIGHT/UNIT (XAAS2). The weight of one unit for tax purposes. This field is defined by your company.

SUPPLEMENTAL WEIGHT (BAAS3). A supplementary weight for an item when the tax weight is given in another unit of measure. For instance if the tax weight is given in kilos, the supplementary weight could be in pounds.

SUPPLEMENTAL WEIGHT U/M (XAAPT) [?]. The unit of measure for the supplemental weight.

UNIT VOLUME (XZ93R). The volume of one unit of the item. This field is used by MRP and COM.

VOLUME UNIT OF MEASURE (XAAPT) [?]. The unit of measure for the volume for this item.

DATE LAST MAINTAINED (MDATE). This field shows the date this Item Master record was last maintained. This field appears on Change, Delete, and Set Defaults displays.

LAST MAINTAINED BY (XAHVN). The user ID of the person who last maintained the Item Master record for this item. This field appears on Change, Delete, and Set Defaults displays.

AMVT04—Item Master File—Costing Information (Add/Change/Delete/Set Defaults)

Use this display to add, change, or delete additional cost information for the item or to set defaults for cost information for the item for this file maintenance session.

This display appears only when B-records are in the Item Master file and you press **Enter** or select **F02 NEXT DISPLAY** on display AMVT03. This display also appears if you select option 4 on display AMVT01.

```

DATE **/**/**                ITEM MASTER FILE                SET DEFAULTS  AMVT04  **
                                -COSTING INFORMATION-                @
ITEM *****
DESCRIPTION *****
COST TECH CODE  A    LABOR HOURS  nnnnnn.nnnnn  STD LOT SIZE  nnnnnnnn.nnn
                                -----CURRENT-----                STANDARD-----
                                TBL CODE          THIS LEVEL          TBL CODE          THIS LEVEL
MATERIAL                nnnnnnnnnnnn.nnnnnnnnn  nnnnnnnnnnnn.nnnnnnnnn
OUTSIDE OPERATIONS      nnnnnnnnnnnn.nnnnnnnnn
PURCHASE OVERHEAD      A    *****.*****  A    *****.*****
SETUP LABOR                nnnnnnnnnnnn.nnnnnnnnn
RUN LABOR                A    nnnnnnnnnnnn.nnnnnnnnn
SETUP MACHINE            nnnnnnnnnnnn.nnnnnnnnn
RUN MACHINE              nnnnnnnnnnnn.nnnnnnnnn
MFG OVERHEAD            A    nnnnnnnnnnnn.nnnnnnnnn
(Other 1)                nnnnnnnnnnnn.nnnnnnnnn
(Other 2)                nnnnnnnnnnnn.nnnnnnnnn
(Other 3)                nnnnnnnnnnnn.nnnnnnnnn
(Other 4)                nnnnnnnnnnnn.nnnnnnnnn
LAST MAINTAINED  **/**/**  BY *****
*** PRESS 'E N T E R' TO CONFIRM/DELETE THIS ITEM ***
                                F02 NEXT DISPLAY
                                F03 PREV DISPLAY
                                F15 NOTE TASKS
                                F18 REFRESH
                                F19 RETURN TO SELECT

```

What to do

- If you selected option 1, All Displays (in sequence), on display AMVT01 and there are C-records in the Item Master file, press **Enter** to work with purchasing information for the item. Go to display AMVT05.
- If you selected option 4, Costing Information; used F02 on display AMVT03 or **F03** on display AMVT05; or if C-records are not in the Item Master file, press **Enter** to update the Item Master File accordingly. Go back to the Item Master Maintenance (Select) display (AMVT01).

Note: The Item Master file is updated with information maintained on any of the following displays: AMVT02, AMVT03, AMVT04, AMVT05.

Function keys

F02 NEXT DISPLAY causes display AMVT05 to appear. If there are no C-records in the Item Master file, this function key does not appear on the display.

F03 PREV DISPLAY causes display AMVT03 to appear.

F15 NOTE TASKS allows you to access the Note Tasks function. If a note exists, an icon, @, appears in the upper right corner of the display. For more information on this function, see the *Planning and Installing Infor ERP XA* book.

F18 REFRESH erases any information you typed in and shows you AMVT04 as it first appeared.

F19 RETURN TO SELECT ignores the information you just entered and causes display AMVT01 to appear again.

Fields

If you are in Add, Change, or Set Defaults mode, **ITEM**, **DESCRIPTION**, and **ITEM TYPE CODE** are informational only. If you are in Delete mode, all fields are informational.

Note: Do not enter negative values in numeric fields.

The current/standard cost element information does not appear on this display if you do not have the proper security level for maintaining Item Master cost fields. The **STD LOT SIZE**, **COST TECHNIQUE CODE**, and **LABOR HOURS** fields always appear on the display, but you cannot type anything in them without the proper security level.

ITEM (ITNBR). This field shows the number of the item you entered on display AMVT01.

Inventory Description. This field appears above the **ITEM TYPE CODE** field and has no heading. This field shows one of four different categories depending on the inventory code:

INVENTORY	If the item is an inventory item
MISCELLANEOUS	If the item is a miscellaneous item
SERVICE	If the item is a service item
UNSTOCKED	If the item is not stocked (no Item Balance file record). Applies to kit only.

DESCRIPTION (ITDSC). This field shows the description of the item you entered on display AMVT02. The description appears on inquiries and reports.

ITEM TYPE CODE (ITYP). Code that best describes the type of item:

0	Phantom
1	Assembly or subassembly
2	Fabricated item
3	Raw material
4	Purchased item
9	User option (Special)
F	Feature
K	Kit

Note: If you selected item type code 9 (user option), PDM does not roll up lower-level costs.

COST TECH CODE (CTECH). Type in the code used to identify the PDM labor costing technique to cost this item. The available codes are:

- blank** The this-level labor and manufacturing overhead values are not to be calculated by PDM product costing. The labor and manufacturing overhead costs that you enter are used.
- R** The this-level labor and manufacturing overhead costs for the item are calculated using the routing hours and the facility rates. Cost technique code R is not valid for item types 3 or 4.
- T** The this-level labor and manufacturing overhead costs for the item are calculated using the labor hours you enter on this display and from the values contained in the Labor/Overhead Table (indicated by the Labor/Overhead TBL codes on this display).

LABOR HOURS (LABHR). Type in the number of labor hours per standard batch quantity for this item. This number is multiplied by the Labor/Overhead Table rates in calculating the labor or manufacturing overhead cost for this-level per unit for this item. This field is used only when the cost technique code equals T.

STD LOT SIZE (Standard Lot Size) (LOTSZ). Type in the standard lot size of the item that is normally ordered. This quantity is used to apportion the setup cost per unit for the item. This field cannot be zeros if the cost technique code is R. MRP (if installed and interfacing) can use this field to determine a quantity based lead time. MPSP (if installed and interfacing) can use this field to calculate resource profiles.

For item types F, 3, 4, and 9, the values you enter in the **MATERIAL and OUTSIDE OPERATIONS (Current and Standard This Level)** fields are used by PDM product costing. If the item type is 0, 1, or 2, the outside operation costs (routing operation with TBC=C) or the values you enter are used by PDM product costing. If the item type is 0, 1, or 2, and the cost technique code is R, any values you enter are recalculated and overlaid during the next full costing run.

MATERIAL—CURRENT THIS LEVEL (CMAT). Type in the cost per unit for material based on current costs.

MATERIAL—STANDARD THIS LEVEL (SMAT). Type in the cost per unit for material based on current costs.

OUTSIDE OPERATIONS—CURRENT THIS LEVEL (COOT). Type in the cost per unit for outside operations based on standard costs.

OUTSIDE OPERATIONS—STANDARD THIS LEVEL (SOOT). Type in the cost per unit for outside operations based on standard costs.

PURCHASE OVERHEAD TBL CODE—CURRENT (CPTAB). Type in a code from the Purchase Overhead Table to indicate the percent to be applied to the current purchase cost in calculating the current purchase overhead cost this-level (CPOTL) for this item. This field is used only when the item type code equals 3, 4, or 9.

PURCHASE OVERHEAD— CURRENT THIS LEVEL (CPOT). This field is informational only. It shows the overhead cost per unit for purchased parts or raw material based on current costs. The value shown is calculated by PDM product costing for item types 3, 4, or 9.

PURCHASE OVERHEAD TBL CODE—STANDARD (SPTAB). Type in a code from the Purchase Overhead Table to indicate the percent to be applied to the standard purchase cost in calculating the standard purchase overhead cost this-level (SPOTL) for this item. This field is used only when the item type code equals 3, 4, or 9.

PURCHASE OVERHEAD— STANDARD THIS LEVEL (SPOT). This field is informational only. It shows the overhead cost per unit for purchased parts or raw material based on standard costs. The value shown is calculated by PDM product costing for item types 3, 4, or 9.

SETUP LABOR—CURRENT THIS LEVEL (CSLT). If the Cost Technique Code is blank, type in the direct cost per unit that is made up of run labor using current costs. If the Cost Technique is T or R, leave this field blank.

SETUP LABOR—STANDARD THIS LEVEL (SSLT). If the Cost Technique Code is blank, type in the direct cost per unit that is made up of run labor using current costs. If the Cost Technique is T or R, leave this field blank.

RUN LABOR TBL CODE—CURRENT (CRLC). If the Cost Technique Code is T, type in a code from the labor rate portion of the Labor/Overhead Table to indicate the rate to be applied to the **RUN LABOR (LABHR)** field in calculating the current run labor cost this-level (CLCTL) for this item. If the Cost Technique Code is blank or R, leave this field blank.

RUN LABOR—CURRENT THIS LEVEL (CRLT). If the Cost Technique Code is blank, type in the direct cost per unit that is made up of run labor using current costs. If the Cost Technique Code is T or R, leave this field blank.

RUN LABOR TBL CODE—STANDARD (SRLC). If the Cost Technique Code is T, type in a code from the labor rate portion of the Labor/Overhead Table to indicate the rate to be applied to the **RUN LABOR (LABHR)** field in calculating the standard unit labor cost this-level (SLCTL) for this item. If the Cost Technique Code is blank or R, leave this field blank.

RUN LABOR—STANDARD THIS LEVEL (SRLT). If the Cost Technique Code is blank, type in the direct cost per unit that is made up of run labor using standard costs. If the Cost Technique Code is T or R, leave this field blank.

SETUP MACHINE—CURRENT THIS LEVEL (CSMT). If the Cost Technique Code is blank, type in the direct cost per unit for setup machine hours using current costs. If the Cost Technique Code is T or R, leave this field blank.

SETUP MACHINE—STANDARD THIS LEVEL (SSMT). If the Cost Technique Code is blank, type in the direct cost per unit for setup machine hours using standard costs. If the Cost Technique Code is T or R, leave this field blank.

RUN MACHINE—CURRENT THIS LEVEL (CRMT). If the Cost Technique Code is blank, type in the direct cost per unit for run machine hours using current costs. If the Cost Technique Code is T or R, leave this field blank.

RUN MACHINE—STANDARD THIS LEVEL (SRMT). If the Cost Technique Code is blank, type in the direct cost per unit for run machine hours using standard costs. If the Cost Technique Code is T or R, leave this field blank.

MFG OVERHEAD TBL CODE—CURRENT (COHC). If the Cost Technique Code is T, type in a code from the overhead portion of the Labor/Overhead Table to indicate

the rate or percent to be applied to the **LABOR HOURS (LABHR)** field or to the current labor cost in calculating the standard unit labor overhead cost this-level (SOCTL) for this item. If the Cost Technique Code is blank or R, leave this field blank.

MFG OVERHEAD —CURRENT THIS LEVEL (COHT). If the Cost Technique Code is blank, type the direct/indirect cost per unit.

MFG OVERHEAD TBL CODE—STANDARD (SOHC). If the Cost Technique Code is T, type in a code from the overhead portion of the Labor/Overhead Table to indicate the rate or percent to be applied to the **LABOR HOURS (LABHR)** field or to the standard labor cost in calculating the standard unit labor overhead cost this-level (SOCTL) for this item. If the Cost Technique Code is blank or R, leave this field blank.

MFG OVERHEAD —STANDARD THIS LEVEL (SOHT). If the Cost Technique Code is blank, type the direct/indirect cost per unit.

The following fields may have different titles, depending on what was chosen in the PDM Control file to identify a user-defined cost element.

OTHER COST 1-4—CURRENT THIS LEVEL. If the Cost Technique Code is blank, type in the current cost for the user-defined cost element.

OTHER COST 1-4—STANDARD THIS LEVEL. If the Cost Technique Code is blank, type in the standard cost for the user-defined cost element.

DATE LAST MAINTAINED (MDATE). This field shows the date this Item Master record was last maintained. This field appears on Change, Delete and Set Defaults displays.

AMVT05—Item Master File—Purchasing Information (Add/Change/Delete/Set Defaults)

Use this display to add, change, or delete purchasing information for the item number or to set defaults for purchasing information for the item for this file maintenance session.

This display appears only when C-records are in the Item Master file and you select action A (add), C (change), D (delete), or S (set defaults) and option 5, Purchasing Information (C-Record) on display AMVT01, or when you press **Enter** or select F02 (Next Display) on display AMVT04.

```

DATE **/**/**                ITEM MASTER FILE                ADD      AMVT05  **
                              -PURCHASING INFORMATION-                @
ITEM *****
DESCRIPTION *****
aaaaaaaaaaaaaaaaaaaaaaaaaaaaaaaaaaaaaaaaA40
aaaaaaaaaaaaaaaaaaaaaaaaaaaaaaaaaaaaaaaaA40

BUYER          aaaA5    ACCT aaaaaaaaaaaaaA15    PUR PRICE  nnnnnnnnnnn.nnnn

RECEIPT REQUIRED      n    -TOLERANCE PERCENTS-    -WEIGHTED PERCENTS-
ALLOW DAYS EARLY   nnn    RECEIVING + %  nnn    LEAD TIME %      nnn
SHIP VIA           aA3    RECEIVING - %  nnn    DELIVERY %       nnn
ALPHA FACTOR       .nnn                    QUALITY %        nnn
PURCH COMMODITY    aaaA5                    PRICE %          nnn
PRE-APPROVED       A                                EARLY DELIVERY % nnn
                                                    LATE DELIVERY % nnn
                                                    OVERSHIP %       nnn
                                                    UNDERSHIP %      nnn

DATE LAST MAINTAINED      **/**/**                LAST MAINTAINED BY *****

                                                    F03 PREV DISPLAY
                                                    F15 NOTE TASKS
                                                    F18 REFRESH
                                                    F19 RETURN TO SELECT
    
```

What to do

To update the Item Master file with the information you added, changed, or deleted, press **Enter**. Go back to the Item Master Maintenance (Select) display (AMVT01).

Note: The Item Master file is updated with information maintained on any of the following displays: AMVT02, AMVT03, AMVT04, or AMVT05.

Function keys

F03 PREV DISPLAY causes display AMVT04 to appear.

F15 NOTE TASKS allows you to access the Note Tasks function. If a note exists, an icon, @, appears in the upper right corner of the display. For more information on this function, see the *Planning and Installing Infor ERP XA* book.

F18 REFRESH erases any information you typed in and shows you AMVT05 as it first appeared.

F19 RETURN TO SELECT ignores the information you just entered and returns to display AMVT01.

Fields

[?] appears next to a field name in the following field definitions to identify a field from which you can begin a master file search.

ITEM (ITNBR). The number of the item you entered on display AMVT01.

Inventory Description. This field appears above the **ITEM TYPE CODE** field and has no heading. This field shows one of four different categories depending on the inventory code:

INVENTORY	If the item is an inventory item
MISCELLANEOUS	If the item is a miscellaneous item
SERVICE	If the item is a service item
UNSTOCKED	If the item is not stocked (no Item Balance file record). Applies to kit only.

DESCRIPTION (ITDSC). The description of the item you entered on display AMVT02. This description appears on inquiries and reports.

ITEM TYPE CODE (ITTYP). Code that best describes the type of item:

0	Phantom
1	Assembly or subassembly
2	Fabricated item
3	Raw material
4	Purchased item
9	User option (Special)
F	Feature
K	Kit

Extended Description (PITD1, PITD2). These fields appear beneath the **DESCRIPTION** field. Use these fields to type in an extended description of the item you are adding. (These fields are used by Purchasing, if installed and interfacing.)

BUYER (BUYNO) [?]. Type in the code that identifies the buyer of the item. This buyer number is used to create purchase orders if no buyer is specified in the primary quotation during MRP Auto-Release.

ACCT (Account Number) (ACCTN) [?]. Required. Type in the number of the account to be charged when this item is invoiced. This field does not appear for IM. The system checks for account numbers in Company 1 only. If you have multiple companies, the system issues a warning message. To bypass the warning message, press **Enter**.

Note: When you search for account numbers, only those valid for company 1 are listed. Valid account numbers for other companies are not listed.

If IFM is installed, the **ACCT** (Account) field is replaced with the **Nature** field.

NATURE (CHGN) [?]. Type in an account or revenue/expense code. Type a ? in this field and press **Enter**. A select panel appears for your selection of a valid nature.

PUR PRICE (PURPR). If this is a purchased item, type the purchase price in this field.

RECEIPT REQUIRED (RECRQ). This field shows whether an inventory transaction (receipt) must be recorded before invoicing can be processed. Type one of these values:

- 1 Receipt required
- 0 Receipt not required.

ALLOW DAYS EARLY (ALLDE). Type in the number of days that are acceptable for early delivery.

SHIP VIA (VIACD) [?]. Type the code that identifies the means by which this item is normally shipped.

ALPHA FACTOR (ALPHA). Type a value to be used in calculating the vendor and buyer weighted performance percentages. If you do not type anything in this field, the value defaults to the value set during application tailoring.

PURCH COMMODITY [?]. A code defined by your company that identifies the commodity classification for this item. If entered, this must be a valid code in the Purchase Item Commodity Class code file. Type ? in this field and press **Enter**. A select panel appears for your selection of a valid code or to add a new code.

PRE-APPROVED (PRAP). A code to indicate if this is an item that can be ordered from the vendor without waiting for approval. This code is used only if you are using the approval process for purchase orders. Security settings in CAS determine if you can maintain this field.

- 0 No. This is a normal item, subject to approval. This is the default.
- 1 Yes. This is a pre-approved item. Either no approval or only memo approval is required for this item, depending on the code in the Memo Approve Pre-approved Items field in the Purchasing Control file.

TOLERANCE PERCENTS.

RECEIVING + % (Receiving Plus Percent) (TOLPO): Type in the user-defined percentage of receipts that can be overdelivered.

RECEIVING – % (Receiving Minus Percent) (TOLPC): Type in the user-defined percentage of receipts that can be underdelivered.

Tolerances are used only in calculating vendor performance in the category of delivery.

WEIGHTED PERCENTS. These user-defined percentages define the relative importance placed on each of the following aspects of vendor performance.

Note: The defaults selected during application tailoring for Purchasing are used unless you type in new values. However, the Purchasing defaults do not appear on the display.

LEAD TIME % (WLTLM): Type the percentage to be placed on variances between quoted and actual vendor lead times. Because you can place different emphasis on early or late delivery, you can also use secondary delivery factor percentages.

DELIVERY % (WTDEL): Type percentage to be placed on variances between ordered and delivered quantities. Because you can place different emphasis on over or under shipment, you can use secondary delivery factor percentages.

QUALITY % (WTQUA): Type the percentage to be placed on reject quantities.

PRICE % (WTPRC): Type the percentage to be placed on variances between quoted and actual vendor prices.

Use the four following secondary delivery factor percents to place additional emphasis on specific delivery conditions:

EARLY DELIVERY % (WTEDL): Type the percentage to be placed on early delivery.

LATE DELIVERY % (WTLDL): Type the percentage to be placed on late delivery.

OVERSHIP % (WTVOS): Type the percentage to be placed on overshipment.

UNDERSHIP % (WTUVS): Type the percentage to be placed on undershipment.

DATE LAST MAINTAINED (MDATE). This field shows the date this Item Master record was last maintained. This field appears on Change, Delete and Set Defaults displays.

LAST MAINTAINED BY (XBAHVN). The user ID of the person who last maintained the Item Master record for this item. This field appears on Change, Delete and Set Defaults displays.

AMVT06—Item Master File Maintenance (Status)

Use this display to review statistics both for the current session and for the Item Master file.

This display appears when you select **F23 (Status)** on display AMVT01.

```

DATE **/**/**          ITEM MASTER FILE MAINTENANCE      STATUS      AMVT06  **

      SESSION STATISTICS
      ADDS ENTERED          ****,***
      CHANGES ENTERED     ****,***
      DELETES ENTERED      ****,***
      TOTAL TRANSACTIONS   ****,***
      MAINTENANCE NUMBER   ***

                                     F24 END OF JOB
  
```

What to do

To continue this file maintenance session, press **Enter**. Go back to the Item Master Maintenance (Select) display (AMVT01) to select another record to maintain.

Function keys

F24 END OF JOB causes the menu to appear again.

Fields

SESSION STATISTICS. The following fields show the individual transaction totals and the total transactions for the current session:

ADDS ENTERED. The number of items added.

CHANGES ENTERED. The number of items changed.

DELETES ENTERED. The number of items deleted.

TOTAL TRANSACTIONS. The total number of records added, changed, and deleted.

MAINTENANCE NUMBER. The total number of times the Item Master file has been maintained.

Option 2. Product Structure (AMEM05)

Use this option anytime you want to do one of the following:

- Add a new component item to the Product Structure file
- Change, delete, mass replace, or mass delete a component already in the file
- Add, change, or delete structure records for the production of a scheduled item
- Copy an existing product structure (same-as-except)
- Delete a product structure
- Change a user sequence number
- Review a product structure (including pending changes)
- Review transactions in a Product Structure file maintenance batch.

Multiple users can maintain different records in the same master file at the same time. This capability is called concurrent master file maintenance.

What information you need:

- Parent item number
- New parent item number
- Component item number.

What reports are printed:

- Product Structure Transaction List (AMEU5)
- Product Structure Update Audit List (AMEB12)
- Requirements Status report (AMM481)—if required by Material Requirements Planning. See the *Material Requirements Planning User' Guide* for more information about this report.

What forms you need: Product Structure File Maintenance—PM-14.

AMEUA1—Product Structure File Maintenance—Data Entry Control

Use this display to select a batch within the Product Structure Maintenance Transaction file to either work on or review.

This display appears when you select option 2 (Product Structure) on the File Maintenance menu (AMEM05).

Note: This display prevents initiation of product structure data entry from additional work stations.

```
DATE **/**/**      PRODUCT STRUCTURE FILE MAINTENANCE      AMEU1  **
                        DATA ENTRY CONTROL
ENTER BATCH NUMBER  nnn      BATCHES CURRENTLY IN USE ***
                                LOCATE BATCH nnn

  BATCH  *--ORIGINAL--*   *---LAST---*
  NO.    WSID   OPID    WSID   OPID    STATUS  DATE    RECORDS
  ***    *****   ***   *****   ***   ***** **/**   *****
  ***    *****   ***   *****   ***   ***** **/**   *****
  ***    *****   ***   *****   ***   ***** **/**   *****
  ***    *****   ***   *****   ***   ***** **/**   *****
  ***    *****   ***   *****   ***   ***** **/**   *****
  ***    *****   ***   *****   ***   ***** **/**   *****
  ***    *****   ***   *****   ***   ***** **/**   *****
  ***    *****   ***   *****   ***   ***** **/**   *****
  ***    *****   ***   *****   ***   ***** **/**   *****
  ***    *****   ***   *****   ***   ***** **/**   *****
  ***    *****   ***   *****   ***   ***** **/**   *****
  ***    *****   ***   *****   ***   ***** **/**   *****

DOWN

                                USE ROLL UP/
                                F04 NEW BATCH
                                F24 CANCEL JOB
```

What to do

- To use an existing batch, type in the batch number and press **Enter**. Go to display AMEU18.
- To start a new batch, use **F04**. Go to display AMEU11.

Function keys

USE ROLL UP/DOWN allows you to scroll up and down through the list of batches on the displays.

F04 NEW BATCH causes a new batch be started.

F24 CANCEL JOB ends the work station session and causes the File Maintenance menu (AMEM05) to appear again.

Fields

ENTER BATCH NUMBER. Required. To edit an existing batch, type in the batch number and press **Enter**.

You can edit a batch whose status is ACTIVE only if the originating work station identifier (**ORIG WSID** field) matches the work station ID in the upper right corner of your display.

You cannot edit batches with a status of UPDATE, FINISH, or DELETE.

BATCHES CURRENTLY IN USE. The number of batches currently in the system. This count includes all batches, regardless of status.

LOCATE BATCH. To find a batch that is in the list but does not appear on the display, type in its batch number and press **Enter**. This is intended as an alternative to the **ROLL UP/DOWN** keys.

BATCH NO. The sequential number assigned by the application to the batch, at the time the batch is created.

ORIGINAL.

WSID (Original work station identification): The work station at which transactions for the batch were originally entered. For offline batches, asterisks appear.

OPID (Original operator identification): The ID of the operator who entered the batch. The operator ID appears only if security is in effect. For offline batches, asterisks appear.

LAST.

WSID (Last work station identification): The work station at which the batch was last selected. For offline batches, asterisks appear.

OPID (Last operator identification): The ID of the operator who last selected the batch. The operator ID appears only if security is in effect. For offline batches, asterisks appear.

STATUS. One of the following batch status indicators:

- | | |
|---------------|--|
| ACTIVE | Indicates either that the batch is being used by another work station or that it is incomplete because of some abnormal condition, such as loss of power. An active batch can be attached to only from the work station that started it. |
| SUSPND | Indicates that the operator has used F23 on one of the Status displays, AMEU18, AMEU35, or AMEU43, to suspend the batch. Apparently, there are more transactions to be entered in the batch. A suspended batch can be selected from any work station. |
| CLOSED | Indicates that the operator has used F24 on one of the Status displays, AMEU18, AMEU35, or AMEU43 to close the batch. The application can use it to update the master files. |
| DELETE | Indicates that the operator has used F20 on one of the Status displays, AMEU18, AMEU35, or AMEU43 to delete the batch. The batch becomes available when the application removes deleted batches from the Product Structure Data Entry file. |
| UPDATE | Indicates that the application has selected the batch for updating the master files. If question X02 was answered Y on the Installation |

[Contents](#)

[Index](#)

Questionnaire, this batch becomes available for starting a new batch as soon as the updating is completed.

FINISH

Indicates that the batch has been applied to the master files but that the transactions remain in the batch until the files are saved (a NO reply to question X03 on the Installation Questionnaire).

DATE. The creation date or date of last activity for the batch.

RECORDS USED. The number of transactions currently in the batch.

AMEU11—Product Structure File Maintenance (Select)

Use this display to select the type of product structure maintenance transaction you want and the item number.

This display appears when you type a valid batch number on display AMEUA1 or if you select **F19 (Return to Select)** on any of the following Product Structure File Maintenance displays: AMEU13, AMEU14, AMEU15, AMEU16, AMEU17, AMEU31, AMEU32, AMEU33, AMEU34, or AMEU41.

Note: After performing Product Structure File Maintenance, you should run option 2 (Calculate Adjusted Quantity Per) on the Yield Calculation menu (AMEM06). If you have maintained the **OPERATION WHERE 1st USED** field, you should first also run option 1 (Calculate Cumulative Yield) on the same menu.

This display allows you to enter the kind of Product Structure maintenance transaction you want and the item number. The maintenance transactions are: add, change, delete, same-as-except (SAE), mass replace, mass delete, structure delete, user sequence change, and review bill including pending changes. You enter the component item number for mass replace and mass delete. For all other transactions, enter the parent item number. You can review the transactions already entered in the batch you are working with or you can go to the status display.

```

DATE **/**/**      PRODUCT STRUCTURE FILE MAINTENANCE      SELECT      AMEU11  **

                                     ENTER--
                                     ITEM      aaaaaaaaaaaaA15      BATCH ***
                                     ACTION  A

SELECT ONE OF THESE ACTIONS
A ADD
C CHANGE
D DELETE
X SAME-AS-EXCEPT
R MASS REPLACE
M MASS DELETE
S DELETE STRUCTURE
U USER SEQUENCE CHANGE
V REVIEW BOM INCLUDING PENDING CHANGES

                                     F05 REVIEW
                                     F24 STATUS
    
```

What to do

To select the type of product structure maintenance you want to perform, type in the item number and action code. Press **Enter**.

Note: The following table shows you whether the item number you type in should be a component or parent item number.

Depending on the action code you selected, one of the following displays appears:

Action Code	Item Number	Information on display AMEU11	Display
A	Add	Parent of component to be added	AMEU12
C	Change	Parent of component to be changed	AMEU13
D	Delete	Parent of component to be deleted	AMEU15
X	Same-as -except	Parent whose structure is to be copied	AMEU31
R	Mass replace	Component to be replaced	AMEU14
M	Mass delete	Component to be deleted	AMEU16
S	Delete structure	Entire product structure to be deleted	AMEU17
U	User sequence change	Parent of component to be changed	AMEU15 or AMEU12
V	Review BOM including pending changes	Parent whose structure is to be reviewed	AMEUG1

Function keys

F05 REVIEW establishes review mode and causes display AMEU41 to appear.

F24 STATUS causes display AMEU18 to appear.

Fields

[?] appears next to a field name in the following field definitions to identify a field from which you can begin a master file search.

ITEM (ITNBR) [?]. Required. Type in the item number of the parent or component item. You enter the component item number for mass replace and mass delete transactions. You enter the parent item number for all other transactions.

ACTION. Required. Type in one of the following action codes:

- A** Add a component to a parent item's product structure.
- C** Change a component in a parent item's product structure.
- D** Delete a component from a parent item's product structure.
- X** Copy the product structure of an existing parent item to create a product structure for a similar new parent item.
Note: When action X is selected, all SAE adds, changes, and deletes to the parent structure being created must be made in SAE mode.
- R** Replace a single component item with a new component item in every product structure where it is used.
- M** Delete a single component item from every product structure where it is used.
- S** Delete an entire product structure at one time.
- U** Change an item's user sequence number. (Action U only appears if user sequence was chosen during application tailoring).

[Contents](#)

[Index](#)

- V** Review a product structure as it should appear after the Product Structure file is updated. This includes any pending add, change, delete, mass replace, mass delete, structure delete, and same-as-except (SAE) transactions in the batch you are working with and in any other closed or suspended batches.

BATCH. This field shows the batch number to which you are currently attached.

AMEU12—Product Structure File Maintenance (Add/Review)

Use this display to add a component to a parent and to enter descriptive data about that component and to review add transactions entered in the Product Structure Maintenance Batch file.

This display appears when you type a valid parent item number and action A (add) on display AMEU11.

This display allows you to add a component to a parent and to enter fields for that component such as user sequence (if applicable), component item number, effective date from and to, operation where first used, feature/option code and number, lead time adjustment, and feature/option planning and cost roll-up factors. The Product Structure File Maintenance entry form, PM-14, can be used with this display.

```

DATE **/**/**      PRODUCT STRUCTURE FILE MAINTENANCE      REVIEW      AMEU12  **
TRAN NO.  TRANSACTION TYPE  PARENT/COMPONENT  PARENT/COMPONENT  SEQ
*****
*****
*****
*****
*****
*****
*****
*****
*****

ADD                                BATCH ***
SEQUENCE                          aaA4

```

```

DATE **/**/**      PRODUCT STRUCTURE FILE MAINTENANCE      ADD      AMEU12  **
PARENT ITEM *****  *****  *****  *****  SBQ **,**,***,***
SEQ COMPONENT ITEM  DESCRIPTION-TRUNC.  QTY PER  UM T ENGR DRAWING
*****
*****
*****
*****
*****
*****
*****
*****
*****
*****

ADD                                BATCH ***
SEQUENCE                          aaA4
COMPONENT ITEM                    aaaaaaaaaaaaaA15  QUANTITY PER      nnnnnnnn.nnn
EFFECTIVE DATE FROM              nnnnnn           EFFECTIVE DATE TO  nnnnnn
OPERATION WHERE 1ST USED         aaA4             LEAD TIME ADJUSTMENT nn.n
FEATURE/OPTION CODE              A                FEATURE/OPTION NUMBER A2
F/O PLANNING FACTOR              n.nnnn          F/O COST ROLL FACTOR n.nnnn
                                         USE ROLL UP/DOWN
                                         F06 PROD-STRUC/BATCH
                                         F19 RETURN TO SELECT
                                         F24 STATUS

```

What to do

- To add a component, type in the information requested and press **Enter**. The component record is added to the batch and the display appears again.
- To review the changes you have made, use **F06** after you press **Enter**. To see the Product Structure file detail, use **F06** again.
- To end the session or review the status of Product Structure file, use **F24**.

Function keys

USE ROLL UP/DOWN allows you to scroll up and down through the list of batches on the displays.

F06 PROD-STRUC/BATCH shows you the changes you have made to the Product Structure Maintenance Batch file on the top portion of the display. Use **F06** again to see AMEU12 with Product Structure file detail.

Note: The information you type on the lower portion of the display will not appear in REVIEW mode until you press **Enter**.

F19 RETURN TO SELECT ignores the data you just entered and causes display AMEU11 to appear again.

F24 STATUS causes display AMEU18 to appear.

Fields

[?] appears next to a field name in the following field definitions to identify a field from which you can begin a master file search.

The fields on the top portion of the display are described first. The top portion of the display shows either detail from the Product Structure Master file (when the display is in ADD mode) or shows the changes you have made to the Product Structure Maintenance Batch file (when the display is in REVIEW mode). The fields shown in ADD mode are described first followed by the fields shown in REVIEW mode and the fields shown on the bottom portion of the display in both modes.

PARENT ITEM (ITNBR). The number of the parent item you entered on display AMEU11.

Description (ITDSC). This field appears to the right of the field Parent Item and has no heading. It shows the description of the parent item that normally appears on invoices, inquiries, and reports.

SBQ (Standard Batch Quantity) (SBQTY). The quantity of this parent item relative to the quantity of each component item. The product structure (recipe or formulation) is expressed in relation to a batch quantity of the parent item as opposed to a quantity of one stocking unit.

SEQ (User Sequence) (USRSQ). The user-designated sequence number for this component that is used to establish the sequence of the bills of material. This field appears only if the user sequence function was chosen during application tailoring.

COMPONENT ITEM (CINBR) [?]. The item number of each component of the parent item.

DESCRIPTION—TRUNC. (ITDSC). A shortened version of the component description that normally appears on invoices, inquiries, and reports.

QTY PER (Quantity Per) (QTYPR). The quantity of the component item used in the production of a standard batch quantity of the parent item.

UM (Unit of Measure) (UNMSR). The code (user assigned) that identifies the measurement basis for onhand quantity and issue quantity for this item; for example, EA (each), KG (kilogram), or CM (centimeter).

T (Item Type Code) (ITYP). A code that best describes the type of item:

0	Phantom
1	Assembly or subassembly
2	Fabricated item
3	Raw material
4	Purchased item
9	User option
F	Feature
K	Kit

ENGR DRAWING (Engineering Drawing Number) (ENGNO). The number of the engineering drawing that defines this item.

The following fields appear on the top portion of the display in REVIEW mode.

TRAN NO. (Transaction Number). The application-assigned number you use in requesting additional transaction detail or in deleting the transaction.

TRANSACTION TYPE (TTYPE). The type of transaction: add, change, or delete a component item; mass replace; mass delete; structure delete; or SAE header, SAE change, SAE delete, or SAE add.

PARENT/COMPONENT (ITNBR). The item numbers involved in the transaction. For same-as-except (SAE) transactions, they show the new parent and old parent item numbers. For mass replace transactions, they show the new and old component item numbers. For all other transactions, they show the parent and component item numbers.

SEQ (User Sequence) (USRSQ). The user-designated sequence number for this component that is used to establish the sequence of the bills of material. This field appears only if the user sequence function was chosen during application tailoring.

The bottom portion of the display shows fields you use to enter data about the component you want to add to the parent item's product structure. These fields appear in both ADD and REVIEW mode. Of the following fields, **COMPONENT ITEM** and **QUANTITY PER** are required. The **BATCH** field is informational only. The remaining fields are optional.

BATCH. The batch number to which you are currently attached.

SEQUENCE (User Sequence) (USRSQ). Type in the sequence number of the component to be added. This number is used to establish the sequence of the bills of material. This field appears only if the user sequence function was chosen during application tailoring.

COMPONENT ITEM (CINBR). Type in the item number of the component to be added.

QUANTITY PER (QTYPR). Type in the quantity of this component item used in the production of a standard batch quantity of the parent item.

Note: This is a signed field. After typing in the field value, remember to press **FIELD EXIT** or **FIELD +** if you entered a positive value or press **FIELD -** if you entered a negative value.

EFFECTIVE DATE FROM (EDATM). Type in the calendar date that this product structure relationship becomes effective. This component is included in the parent item's structure for a run date that is equal to or later than this effective date.

EFFECTIVE DATE TO (EDATO). Type in the calendar date that this product structure relationship is no longer effective. This component is included in the parent item's structure for a run date that is earlier than this effective date.

If **Effective Date From** and **Effective Date To** are both entered, this component is included in the parent item's structure for a run date that is later than or equal to **Effective Date From** and earlier than **Effective Date To**.

OPERATION WHERE 1ST USED (OPWFU). Type in the sequence number of the operation where this component is first used in the parent item's routing operations. The operation sequence number you type here must exist in the parent item's routing if the Repetitive Production Management application is installed.

LEAD TIME ADJUSTMENT (LTADJ). Type in the number of shop days prior to the parent item's due date that this component item must be available for use in assembling the parent. For example, if the manufacture lead time for a parent is 30 days and the component is not required until the last operation (which takes three days to complete), the lead time adjustment for this component would be equal to 3. When a value is typed in this field, the normal lead time is not used for this component.

FEATURE/OPTION CODE (FOPCD). Type in one of the following codes:

blank Component is neither a feature nor an option.
N Component is a nonrequired feature; parent is an end-item.
R Component is a required feature; parent is an end-item.
O Component is an option; parent is a feature.

This field must be left blank if feature/options was not installed during application tailoring. If O is entered, the parent must be a feature and the component must not be a feature. If N or R is entered, the parent must be an end-item that is not a feature and the component must be a feature.

FEATURE/OPTION NUMBER (FOPNO). Type in the feature number (the position within the S-number of the feature) or option number of this component; for example, feature 01 or option 02. This field can have a nonzero value only when the feature/option code (FOPCD) is O, N, or R.

Note: Option numbers can be alphanumeric.

F/O PLANNING FACTOR (FOPPF). Type in the feature/option planning factor associated with this component. This factor indicates to MRP's planning run the average percentage of the finished items built with this option. It is used only with

[Contents](#)

[Index](#)

MRP. The same value is normally entered for the feature/options cost roll-up factor. This field can have a nonzero value only when the feature/option code (FOPCD) is O.

F/O COST ROLL FCTR (FOPCF). Type in the feature/option cost roll factor associated with this component. This factor indicates to PDM's product costing what portion of the component (option) cost is to be rolled-up into the parent's (feature's) cost fields. It is used to calculate the average cost for the end-item. This field is used only if you answered yes to the product costing question in the PDM Questionnaire. This field can have a nonzero value only when the feature/option code (FOPCD) is O and product costing is installed.

AMEU13—Product Structure File Maintenance (Change/Review)

Use this display to change component detail for each component in a parent item's product structure and to review change transactions entered in the Product Structure Maintenance Batch file.

This display appears when you type a valid parent item number and action C (change) on display AMEU11.

```

DATE **/**/**      PRODUCT STRUCTURE FILE MAINTENANCE      CHANGE      AMEU13  **
PARENT ITEM ***** SBQ **, **, **, **, **, **
SEQ COMPONENT ITEM  DESCRIPTION-TRUNC.      QTY PER  UM T ENGR DRAWING
**** *****
**** *****
**** *****
**** *****
**** *****
**** *****
**** *****
**** *****
**** *****
**** *****
**** *****
**** *****
**** *****
**** *****
**** *****
**** *****
**** *****
**** *****

CHANGE      *****
SEQUENCE    aaA4          QUANTITY PER          nnnnnnn
COMPONENT ITEM  aaaaaaaaaaA15  LEAD TIME ADJUSTMENT  nn.n
EFFECTIVE DATE FROM  nnnnnn      EFFECTIVE DATE TO     nnnnnn
OPERATION WHERE 1ST USED aaA4          FEATURE/OPTION NUMBER A2
FEATURE/OPTION CODE  A              F/O COST ROLL FACTOR n.nnnn
F/O PLANNING FACTOR n.nnnn      USE ROLL UP/

DOWN                                               F06 PROD-STRUC/BATCH
                                               F18 REFRESH BOTTOM
                                               F19 RETURN TO SELECT
                                               F24 STATUS
    
```

What to do

- To change component detail, type in the sequence number and press **Enter**. Then type in the information requested and press **Enter** again. The updated component record is added to the batch and the display appears again.
- To review the changes you have made, use **F06** after you press **Enter**. To see the Product Structure file detail, use **F06** again.
- To end the session or review the status of Product Structure file, use **F24**.

Function keys

USE ROLL UP/DOWN allows you to scroll up and down through the list of batches on the displays.

F06 PROD-STRUC/BATCH shows you the changes you have made to the Product Structure Maintenance Batch file on the top portion of the display. Use **F06** again to see AMEU13 with Product Structure Master file detail.

Note: The information you type on the lower portion of the display will not appear in REVIEW mode until you press **Enter**.

F18 REFRESH BOTTOM erases any data you typed in and shows AMEU13 as it first appeared.

[Contents](#)

[Index](#)

F19 RETURN TO SELECT ignores the data you just entered and causes display AMEU11 to appear again.

F24 STATUS causes display AMEU18 to appear.

Fields

See “AMEU12—Product Structure File Maintenance (Add/Review)” for descriptions of the fields that appear on this display.

F19 RETURN TO SELECT ignores the data you just entered and causes display AMEU11 to appear again.

F24 STATUS causes display AMEU18 to appear.

Fields

[?] appears next to a field name in the following field definitions to identify a field from which you can begin a master file search.

See “AMEU12—Product Structure File Maintenance (Add/Review)” for descriptions of the fields that appear on the top half of this display.

The bottom half of the display shows fields you use to enter data about the new component that you want used to replace the old component in the product structures of all affected parents. New Component Item is required. The **BATCH** field is informational only. The remaining fields are optional.

NEW COMPONENT ITEM (ITNBR) [?]. Type in the item number of the new component that you want used to replace the old component in all affected product structures.

EFFECTIVITY CHANGE. If there is no effective date change, no entry is necessary as N is the default. Type in Y if this is an effective date change.

EFFECTIVE DATE. Type in a calendar date only if you entered Y for Effectivity Change. This date becomes the **Effective Date To** (EDATO) for the old component and the **Effective Date From** (EDATM) for the new component.

BATCH. The number of the batch to which you are currently attached.

AMEU15—Product Structure File Maintenance (Delete/Review)

Use this display to delete a component from a single parent item's product structure and to review the delete transactions entered in the Product Structure Maintenance Batch file.

This display appears when you type a valid parent item number and action D (delete) on display AMEU11.

```

DATE **/**/**      PRODUCT STRUCTURE FILE MAINTENANCE      DELETE      AMEU15  **
SEQ COMPONENT ITEM  DESCRIPTION-TRUNC.      QTY PER  UM T ENGR DRAWING
DELETE                                                    BATCH  ***

SEQUENCE          aaA4
COMPONENT ITEM    aaaaaaaaaaaaA15 *****
PRESS ENTER TO DELETE COMPONENT

USE ROLL UP/DOWN
F06 PROD-STRUC/BATCH
F19 RETURN TO SELECT
F24 STATUS

```

What to do

- To delete a component from a product structure, type in the information requested and press **Enter**. To confirm the transaction, press **Enter** again. The updated parent item record is added to the batch and the display appears again.
- To review the changes you have made, use **F06** after you press **Enter**. To see the Product Structure file detail, use **F06** again.
- To end the session or review the status of Product Structure file, use **F24**.

Function keys

USE ROLL UP/DOWN allows you to scroll up and down through the list of batches on the displays.

F06 PROD-STRUC/BATCH shows you the changes you have made to the Product Structure Maintenance Batch file on the top portion of the display. Use **F06** again to see AMEU15 with Product Structure Master file detail.

Note: The information you type on the lower portion of the display will not appear in REVIEW mode until you press **Enter**.

F19 RETURN TO SELECT ignores the data you just entered and causes display AMEU11 to appear again.

F24 STATUS causes display AMEU18 to appear.

Fields

[?] appears next to a field name in the following field definitions to identify a field from which you can begin a master file search.

See “AMEU12—Product Structure File Maintenance (Add/Review)” for descriptions of the fields that appear on the top half of this display.

The bottom half of the display shows fields you use to enter data about the component you want to delete in the parent item’s product structure. Component Item is required. The **BATCH** field is informational only. The remaining fields are optional.

BATCH. The number of the batch to which you are currently attached.

SEQUENCE (User Sequence) (USRSQ). Type in the sequence number for the component to be deleted. This number is used to establish the sequence of the bills of material. This field appears only if the user sequence function was chosen during application tailoring.

COMPONENT ITEM (ITNBR) [?]. Type in the item number of the component to be deleted from the parent item’s product structure.

F19 RETURN TO SELECT does not delete the component item and causes display AMEU11 to appear again.

F24 STATUS causes display AMEU18 to appear.

Fields

The top half of the display shows the following informational fields:

COMPONENT ITEM (ITNBR). The number of the component item you entered on display AMEU11.

Description (ITDSC). This field appears to the right of the field COMPONENT ITEM and has no heading. It shows the description of the component item that normally appears on invoices, inquiries, and reports.

PARENT ITEM (ITNBR). The item number of each parent item using the component.

DESCRIPTION-TRUNC. (ITDSC). A shortened (cut off) version of the description of the parent item that normally appears on invoices, inquiries, and reports.

SEQ (User Sequence) (USRSQ). The sequence number assigned by your company for this component that is used to establish the sequence of the bills of material. This field appears only if the user sequence function was chosen during application tailoring.

QTY PER (Quantity Per) (QTYPR). The quantity of this component item used in the production of a standard batch quantity of the parent item.

UM (Unit of Measure) (UNMSR). The code (user assigned) that identifies the measurement basis of onhand and issue quantity for this item, for example EA (each), KG (kilogram), or CM (centimeter).

T (Item Type Code) (ITTYP).

0	Phantom
1	Assembly or subassembly
2	Fabricated item
3	Raw material
4	Purchased item
9	User option
F	Feature
K	Kit

ENGR DRAWING (Engineering Drawing Number) (ENGNO). The number of the engineering drawing that defines this item.

[Contents](#)

[Index](#)

The bottom half of this display shows the following informational fields. The **COMPONENT ITEM** and **Description** fields are repeated.

BATCH. The batch number to which you are currently attached.

Note: When you are certain that you want the displayed component deleted from all product structures using it, press **Enter**.

AMEU17—Product Structure File Maintenance (Structure Delete/Review)

Use this display to delete a parent item's product structure including all of its components and to review the delete transactions entered in the Product Structure Maintenance Batch file.

This display appears when you type a valid parent item number and action S (delete structure) on display AMEU11.

Warning: Be certain that you are deleting Product Structure records for the correct parent item.

```

DATE **/**/**          PRODUCT STRUCTURE FILE MAINTENANCE          STRUCT DEL AMEU17  **
PARENT ITEM ***** SEQUENCE ***** SEQ **,***,***.***
SEQ COMPONENT ITEM   DESCRIPTION-TRUNC.          QTY PER  UM  T  ENGR  DRAWING
*****
*****
*****
*****
*****
*****
*****
*****
*****
*****
*****
*****
*****
*****
*****
*****
*****
*****
*****
*****

STRUCTURE DELETE                      BATCH  ***

      PRESS ENTER TO DELETE THE ABOVE PARENT'S COMPONENTS

                                       USE ROLL UP/DOWN
                                       F06 PROD-STRUC/BATCH
                                       F19 RETURN TO SELECT
                                       F24 STATUS

```

What to do

- To delete a parent item’s product structure, including all component items, type in the information requested and press **Enter**. The updated parent item records are added to the batch and the display appears again.
- To review the changes you have made, use **F06** after you press **Enter**. To see the Product Structure file detail, use **F06** again.
- To end the session or review the status of Product Structure file, use **F24**.

Function keys

USE ROLL UP/DOWN allows you to scroll up and down through the list of batches on the displays.

F06 PROD-STRUC/BATCH shows you the changes you have made to the Product Structure Maintenance Batch file on the top portion of the display. Use **F06** again to see AMEU17 with Product Structure Master file detail.

Note: The information you type on the lower portion of the display will not appear in REVIEW mode until you press **Enter**.

[Contents](#)

[Index](#)

F19 RETURN TO SELECT does not delete the product structure and causes the display AMEU11 to appear again.

F24 STATUS causes display AMEU18 to appear.

Fields

See “AMEU12—Product Structure File Maintenance (Add/Review)” for descriptions of the fields that appear on the top half of this display.

BATCH. The number of the batch to which you are currently attached.

AMEU18—Product Structure File Maintenance (Batch Status)

Use this display to review the status of the Product Structure file and of the batch to which you are currently attached.

This display appears if you selected a closed, suspended, or active batch on the Product Structure Data Entry Control display AMEUA1, or if you select **F24 (Status)** on any of the following displays: AMEU11, AMEU12, AMEU13, AMEU14, AMEU15, AMEU16, or AMEU17.

This display shows you the status of the Product Structure file maintenance batch. The batch statistics shown are adds, changes, and deletes entered; same-as-excepts, mass replaces and mass deletes entered; structure deletes entered; adds, changes, and deletes generated from mass replace; and total transactions in the batch. Press **Enter** to return to the display you were on before.

Note: To avoid any conflicts with other jobs, you should use **F23** to suspend the batch and update the Product Structure file at a later time. If the batch is suspended, no reports are printed. If you want to close the batch, make sure there are no conflicts with any other jobs.

```

DATE **/**/**      PRODUCT STRUCTURE FILE MAINTENANCE      BATCH STATUS AMEU18  **
                                     BATCH STATISTICS                                     BATCH ***
ADDs ENTERED                *****
CHANGES ENTERED            *****
DELETES ENTERED              *****
SAME-AS-EXCEPTS           ***
MASS REPLACES                ***
MASS DELETES                 ***
STRUCTURE DELETES            ***
ADDs GENERATED              *****
CHANGES GENERATED          *****
DELETES GENERATED           *****

TOTAL TRANSACTIONS          *****

QUANTITY TOTAL  *,***,***,***.***

                                     F04 UPDATE NOW
                                     F20 DELETE BATCH
                                     F23 SUSPEND BATCH
                                     F24 CLOSE BATCH
    
```

What to do

- To close and update the batch immediately, use **F04**. Your work station is not available until the update is complete. The application schedules the reports for printing.
- To delete the batch, use **F20**. You must use **F20** twice to confirm the delete. The application schedules the reports for printing.
- To suspend the batch, use **F23**.
- To close the batch and schedule a job to update the batch, use **F24**. The application schedules the reports for printing.

The File Maintenance menu (AMEM05) appears.

Function keys

F04 UPDATE NOW closes the batch and processes it immediately for update to the Product Structure file. Your work station is attached to the Product Structure File Load and Maintenance program (AMEB1) until completion of all updates. Upon completion, the File Maintenance menu (AMEM05) appears again.

F20 DELETE BATCH Schedules a job to delete the batch and causes the File Maintenance menu (AMEM05) to appear again.

Use **F20** again to confirm the batch deletion.

F23 SUSPEND BATCH suspends your batch and causes the File Maintenance menu (AMEM05) to appear again.

F24 CLOSE BATCH Schedules a job to process the closed batch and causes the File Maintenance menu (AMEM05) to appear again.

Fields

All of the fields on this display are informational only.

BATCH STATISTICS.

ADDS ENTERED: The number of add transactions entered.

CHANGES ENTERED: The number of change transactions entered.

DELETES ENTERED: The number of delete transactions entered.

SAME-AS-EXCEPTS: The number of same-as-except transactions (Header, Change, Delete, or Add) entered.

MASS REPLACES: The number of mass replace transactions entered.

MASS DELETES: The number of mass delete transactions entered.

STRUCTURE DELETES: The number of structure delete transactions entered.

ADDS GENERATED: The number of records added (generated) due to same-as-except (or mass replace) transaction entries.

CHANGES GENERATED: The number of changes generated due to same-as-except or mass replace transaction entries.

DELETES GENERATED: The number of deletions generated due to same-as-except, mass replace, and/or mass delete transaction entries.

TOTAL TRANSACTIONS: The total number of transactions in the batch.

QUANTITY TOTAL: The number generated by adding the product structure add quantities (QTYPR). It is used as a hash total to audit the Product Structure maintenance.

Function keys

USE ROLL UP/DOWN allows you to scroll up and down through the list of batches on the displays.

F19 RETURN TO SELECT ignores the data you just entered and causes display AMEU11 to appear again.

F24 STATUS causes display AMEU35 to appear.

Fields

[?] appears next to a field name in the following field definitions to identify a field from which you can begin a master file search.

PARENT ITEM (ITNBR). The number of the parent item you entered on display AMEU11.

Description (ITDSC). This field appears to the right of the **PARENT ITEM** field and has no heading. It shows the description of the parent item that normally appears on invoices, inquiries, and reports.

SBQ (Standard Batch Quantity) (SBQTY). The quantity of this parent item relative to the quantity of each component item. The product structure (recipe or formulation) is expressed as a batch quantity of the parent item as opposed to a quantity of one stocking unit.

SEQ (User Sequence) (USRSQ). The user-designated sequence number for this component that is used to establish the sequence of the bills of material. This field appears only if the user sequence function was chosen during application tailoring.

COMPONENT ITEM (ITNBR). The item number of each component of the parent item.

DESCRIPTION-TRUNC. (ITDSC). An abbreviated version of the description of the component item that normally appears on invoices, inquiries, and reports.

QTY PER (Quantity Per) (QTYPR). The quantity of the component item used in the production of a standard batch quantity of the parent item.

UM (Unit of Measure) (UNMSR). The code (user-assigned) that identifies the measurement basis of onhand and issue quantity for this item; for example, EA (each), KG (kilogram), or CM (centimeter).

T (Item Type Code) (ITYP)

0	Phantom
1	Assembly or subassembly
2	Fabricated item
3	Raw material
4	Purchased item
9	User option
F	Feature
K	Kit

[Contents](#)

[Index](#)

ENGR DRAWING (Engineering Drawing Number) (ENGNO). The number of the engineering drawing that defines this item.

The bottom half of the display shows the **NEW PARENT ITEM** field, which is required, and the **BATCH** field, which is informational only.

BATCH. The number of the batch to which you are currently attached.

NEW PARENT ITEM [?]. Type in the item number of the new parent.

Note: After you type a new parent item number, you cannot return to this display without starting a new cycle (by typing another new parent item number).

What to do

- To change a component item, in the product structure you copied, type in the information requested and press **Enter**. Press **Enter** again to confirm the transaction.
- To end the session or review the status of Product Structure file, use **F24**. Go to display AMEU35.

Function keys

Notes:

1. If you decide not to change any values for the component item you entered and want to change another component using this display, use **F07**. This returns the fields in the bottom half of the display to blanks (including **COMPONENT ITEM**.) You can now type in the item number of the next component you want to change.
2. If you type in changes to the fields and decide not to enter them, use **F18**. This returns the fields in the bottom half of the display back to their original values. You can now type in the new changes for the component item.
3. All transactions for this parent item should be completed before you use **F19**. A duplicate structure is created if you leave SAE mode and return using the same parent item again.

USE ROLL UP/DOWN allows you to scroll up and down through the components shown on the top half of the display.

F07 SAE CHANGE causes display AMEU32 to appear again with all fields in the bottom half of the display set to blanks.

F08 SAE DELETE causes display AMEU33 to appear again with all fields in the bottom half of the display set to their original values.

F09 SAE ADD causes display AMEU34 to appear.

F18 REFRESH BOTTOM erases any data you typed in and shows display AMEU32 as it first appeared.

F19 RETURN TO SELECT ignores the data you just entered and causes display AMEU11 to appear again.

F24 STATUS causes display AMEU35 to appear.

Fields

See “AMEU31—Product Structure File Maintenance (SAE Header)” for descriptions of the fields that appear on the top half of this display.

NEW PARENT ITEM. The number of the new parent item you entered on display AMEU31.

BATCH. The batch number to which you are currently attached.

See “AMEU12—Product Structure File Maintenance (Add/Review)” for descriptions of the remaining fields on the bottom half of this display.

F08 SAE DELETE causes display AMEU33 to appear again with the **COMPONENT ITEM** field set to blanks. Use this function key when you have entered the component but decide not to delete this component.

F09 SAE ADD causes display AMEU34 to appear.

F19 RETURN TO SELECT ignores the data you just entered and causes display AMEU11 to appear again.

F24 STATUS causes display AMEU35 to appear.

Fields

[?] appears next to a field name in the following field definitions to identify a field from which you can begin a master file search.

See “AMEU31—Product Structure File Maintenance (SAE Header)” for descriptions of the fields that appear on the top half of this display.

NEW PARENT ITEM. The number of the new parent item you entered on display AMEU31.

SEQUENCE (User Sequence) (USRSQ). Type in the sequence number for the component to be deleted. This number is used to establish the sequence of the bills of material. This field appears only if the user sequence function was chosen during application tailoring.

BATCH. The batch number to which you are currently attached.

COMPONENT ITEM (ITNBR) [?]. Required. Type in the item number of the component to be deleted.

AMEU34—Product Structure File Maintenance (SAE Add)

Use this display to add components to the new parent item's product structure you copied using display AMEU31.

This display appears when you select **F09 SAE ADD** on either display AMEU32 or AMEU33.

After you enter the component item number and press **Enter**, an SAE Add transaction is created. This display appears again and you can add another component for the same parent item's product structure.

If you decide not to add a component, select **F09 SAE ADD**.

```

DATE **/**/**          PRODUCT STRUCTURE FILE MAINTENANCE          SAE ADD    AMEU34  **
PARENT ITEM *****  *****                                     SEQ **,**,***,***,***
SEQ COMPONENT ITEM  DESCRIPTION-TRUNC.          QTY PER   UM T ENGR DRAWING
**** *****      *****                                     **** **
**** *****      *****                                     **** **
**** *****      *****                                     **** **
**** *****      *****                                     **** **
**** *****      *****                                     **** **
**** *****      *****                                     **** **
**** *****      *****                                     **** **
**** *****      *****                                     **** **
**** *****      *****                                     **** **
**** *****      *****                                     **** **
**** *****      *****                                     **** **
**** *****      *****                                     **** **
**** *****      *****                                     **** **
**** *****      *****                                     **** **
**** *****      *****                                     **** **

SAE ADD               NEW PARENT ITEM *****  SEQUENCE aaA4          BATCH ***
COMPONENT ITEM      aaaaaaaaaaaaaA15          QUANTITY PER          nnnnnnnn.nnn
EFFECTIVE DATE FROM nnnnnn                   EFFECTIVE DATE TO     nnnnnn
OPERATION WHERE 1ST USED aaA4             LEAD TIME ADJUSTMENT nn.n
FEATURE/OPTION CODE A
FEATURE/OPTION NUMBER A2                       USE ROLL UP/DOWN
F/O PLANNING FACTOR n.nnnn                      F07 SAE CHANGE
F/O COST ROLL FCTR n.nnnn                       F08 SAE DELETE
                                               F09 SAE ADD
                                               F19 RETURN TO SELECT
                                               F24 STATUS
  
```

What to do

- To add a component item, type in the information requested and press **Enter**. This display appears again.
- To end the session or review the status of Product Structure file, use **F24**. Go to display AMEU35.

Function keys

USE ROLL UP/DOWN allows you to scroll up and down through the list of batches on the displays.

F07 SAE CHANGE causes display AMEU32 to appear again.

F08 SAE DELETE causes display AMEU33 to appear again.

F09 SAE ADD causes display AMEU34 to appear again with the COMPONENT ITEM field (and any other fields you may have entered) returned to blanks. Use this function key if you decide not to add this component.

F19 RETURN TO SELECT ignores the data you just entered and causes display AMEU11 to appear again.

F24 STATUS causes display AMEU35 to appear.

Fields

See “AMEU31—Product Structure File Maintenance (SAE Header)” for descriptions of the fields that appear on the top half of this display.

NEW PARENT ITEM. The number of the new parent item that you entered on display AMEU31.

BATCH. The number of the batch to which you are currently attached.

See “AMEU12—Product Structure File Maintenance (Add/Review)” for descriptions of the remaining fields on this display.

AMEU35—Product Structure File Maintenance (Batch Status)

Use this display to review the status of the Product Structure file and of the batch to which you are currently attached.

This display appears when you select a closed, suspended, or active batch on display AMEUA1, or when you select **F24 STATUS** on any of the following Product Structure File Maintenance displays: AMEU31, AMEU32, AMEU33, or AMEU34.

```

DATE **/**/**      PRODUCT STRUCTURE FILE MAINTENANCE      BATCH STATUS AMEU35  **
                                     BATCH STATISTICS                                     BATCH ***
ADD5 ENTERED                *****
CHANGES ENTERED           *****
DELETES ENTERED            *****
SAME-AS-EXCEPTS         ***
MASS REPLACES              ***
MASS DELETES               ***
STRUCTURE DELETES         ***
ADD5 GENERATED            *****
CHANGES GENERATED        *****
DELETES GENERATED         *****

TOTAL TRANSACTIONS         *****

QUANTITY TOTAL *,***,***,***.***

                                     F04 UPDATE NOW
                                     F20 DELETE BATCH
                                     F23 SUSPEND BATCH
                                     F24 CLOSE BATCH

```

What to do

- To close the batch and update the batch immediately, use **F04**. Your work station is not available until the update is complete. PDM schedules the reports for printing.
- To delete the batch, use **F20**. You must use **F20** twice to confirm the delete. PDM schedules the reports for printing.
- To suspend the batch, use **F23**.
- To close the batch and schedule a job to update the batch, use **F24**. PDM schedules the reports for printing.

The File Maintenance menu (AMEM05) appears again.

Function keys

You should suspend the batch using **F23** and update the Product Structure file at a later time to avoid conflicts with any other jobs.

F04 UPDATE NOW closes the batch and processes it immediately for update to the Product Structure file. Your work station is attached to the Product Structure File Load and Maintenance program (AMEB1) until completion of all updates. Upon completion, the File Maintenance menu (AMEM05) appears again.

F20 DELETE BATCH Schedules a job to delete the batch and causes the File Maintenance menu (AMEM05) to appear again.

Use **F20** again to confirm the batch deletion.

F23 SUSPEND BATCH suspends your batch and causes the File Maintenance menu (AMEM05) to appear again.

Note: You should suspend the batch using **F23** and update the Product Structure file at a later time to avoid conflicts with any other jobs.

F24 CLOSE BATCH Schedules a job to process the closed batch and causes the File Maintenance menu (AMEM05) to appear again.

Fields

All of the fields on this display are informational only.

See “AMEU18—Product Structure File Maintenance (Batch Status)” for descriptions of the fields on this display.

AMEU41—Product Structure File Maintenance (Review)

Use this display to review the transactions you entered into the batch.

This display appears when you select **F05 REVIEW** on display AMEU11.

Because the Product Structure file is updated in batch mode, you can review this batch's transactions. If you see an error, you can delete the transaction in error, return to the select display, and reenter it correctly. On the review display, you can enter the number of the transaction you want to review and whether you want to see additional detail or if you want to delete that transaction.

If you enter action A and a valid transaction number, display AMEU42 appears. If you enter action D and a valid transaction number, this display appears again for you to confirm the delete. Pressing **Enter** confirms the deletion. The transaction is deleted and this display appears again so that you can delete another transaction or see additional detail for another transaction type.

If you see an error in a transaction during review, delete the transaction, return to the Select display, and enter it again correctly.

If you decide not to delete a transaction, select **F19 RETURN TO SELECT**.

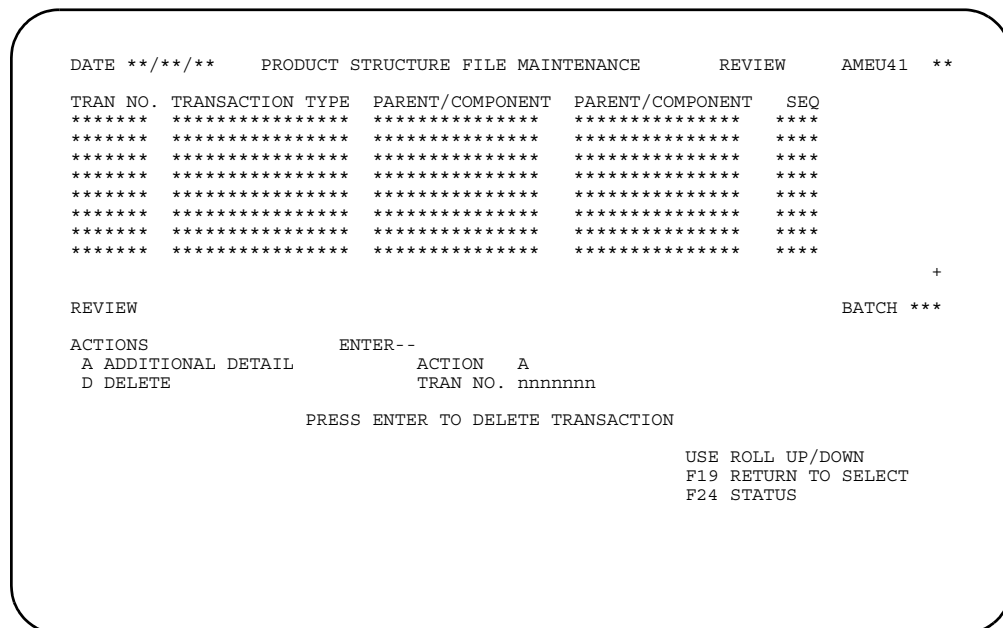

What to do

- To look at additional detail, type **A** in the **ACTION** field and type the transaction number in the **TRAN NO.** field. Press **Enter** and go to display AMEU42.
- To delete a transaction, type in **D** in the **ACTION** field and the transaction number. Press **Enter**. Press **Enter** again to confirm the transaction.
- To end the session or review the status of Product Structure file, use **F24**. Go to display AMEU43.

Function keys

USE ROLL UP/DOWN allows you to scroll up and down through the list of batches on the displays.

F19 RETURN TO SELECT ignores the data you just entered and causes display AMEU11 to appear again.

F24 STATUS causes display AMEU43 to appear.

Fields

TRAN NO. (Transaction Number). The application-assigned number you use in requesting additional transaction detail or in deleting the transaction.

TRANSACTION TYPE (TTYPE). The type of transaction: add, change, or delete a component item; mass replace; mass delete; structure delete; or SAE header, SAE change, SAE delete, or SAE add.

PARENT/COMPONENT (ITNBR). The item numbers involved in the transaction. For same-as-except (SAE) transactions, they show the new parent and old parent item numbers. For mass replace transactions, they show the new and old component item numbers. For all other transactions, they show the parent and component item numbers.

SEQ (User Sequence) (USRSQ). The user-designated sequence number for this component that is used to establish the sequence of the bills of material. This field appears only if the user sequence function was chosen during application tailoring.

BATCH. The batch number to which you are currently attached.

ACTION. Required. Type in either **A** for additional detail or **D** for delete.

TRAN NO. (Transaction Number). Required. Type in the number of the transaction which you want to delete or for which you want to see additional detail. The transaction numbers appear in the far left column of the display. You can request additional detail for transactions having transaction types of add, change, SAE add, or SAE change.

AMEU42—Product Structure File Maintenance (Review)

Use this display to review the additional detail for the transaction you selected.

This display appears when you type a valid transaction number and action A (additional detail) on display AMEU41.

```

DATE **/**/**      PRODUCT STRUCTURE FILE MAINTENANCE      REVIEW      AMEU42  **
TRAN NO.  TRANSACTION TYPE  PARENT          COMPONENT      SEQ      BATCH
*****  *****
                                QUANTITY PER      *****.***
                                EFFECTIVE DATE FROM  **/**/**
                                EFFECTIVE DATE TO    **/**/**
                                OPERATION WHERE 1ST USED  ****
                                LEAD TIME ADJUSTMENT    **
                                FEATURE/OPTION CODE      *
                                FEATURE/OPTION NUMBER    **
                                F/O PLANNING FACTOR       *.****
                                F/O COST ROLL FACTOR      *.****

                                PRESS ENTER TO CONTINUE
  
```

What to do

Review the product structure information and press **Enter** to continue. Go to display AMEU41.

Function keys

USE ROLL UP/DOWN allows you to scroll up and down through the list of batches on the displays.

F19 RETURN TO SELECT ignores the data you just entered and causes display AMEU11 to appear again.

F24 STATUS causes display AMEU43 to appear.

Fields

TRAN NO. (Transaction Number). The number of the transaction for which you requested to see additional detail.

TRANSACTION TYPE. The type of transaction (add, change, SAE add, or SAE change) for which you requested to see additional detail.

PARENT (ITNBR). The number of the parent item whose product structure is affected by this addition or change.

COMPONENT (ITNBR). The number of the component item whose additional detail is shown.

SEQ (User Sequence) (USRSQ). The user-designated sequence number for this component that is used to establish the sequence of the bills of material. This field appears only if the user sequence function was chosen during application tailoring.

BATCH. The number of the batch to which you are currently attached.

The following informational fields show data entered on any of the following Product Structure File Maintenance displays: AMEU12, AMEU13, AMEU34, or AMEU32. For an add or change, if you see an error in this data you must delete the entire transaction using display AMEU41. For an SAE error, the header and all associated transactions must be deleted. Return to display AMEU11 and use the Add, Change, or SAE displays to enter the correct transactions.

QUANTITY PER (QTYPR). The quantity of this component item used in the production of a standard batch quantity of the parent item.

EFFECTIVE DATE FROM (EDATM). Indicates when the component is included in the parent item's product structure for any calendar date that is equal to or later than this effective date.

EFFECTIVE DATE TO (EDATO). Indicates when the component is included in the parent item's product structure for any calendar date that is earlier than this effective date.

If the **EFFECTIVE DATE FROM** field and the **EFFECTIVE DATE TO** field are both shown, the component is included in the parent's structure for any calendar date that is later than or equal to effective date from (EDATM) and earlier than effective date to (EDATO).

OPERATION WHERE 1ST USED (OPWFU). The first parent routing operation in which this component is used.

LEAD TIME ADJUSTMENT (LTADJ). The number of shop days prior to the parent item's due date that the component item must be available for use in assembling the parent. When a value is typed in this field, the normal lead time is not used for this component.

FEATURE/OPTION CODE (FOPCD). Indicates one of the following codes:

- blank** Component is neither a feature nor an option.
- N** Component is a nonrequired feature; parent is an end-item.
- R** Component is a required feature; parent is an end-item.
- O** Component is an option; parent is a feature.

FEATURE/OPTION NUMBER (FOPNO). The number (user-assigned) used to identify a feature or option. If you use features and options, be sure to coordinate this field with the format you established when you answered the PDM Questionnaire. If you answered 1 to the option field size for a respective feature, then be sure your option number is 9 or less.

Note: Option numbers can be alphanumeric.

[Contents](#)

[Index](#)

F/O PLANNING FACTOR (FOPPF). Indicates to MRP's planning run the average portion of the finished items built with this option. The same value is normally entered for the feature/options cost roll-up factor.

F/O COST ROLL FACTOR (FOPCF). Indicates to PDM's product costing what portion of the component (option) cost is to be rolled-up into the parent's (feature's) cost fields. It is used to calculate the average cost for the end-item. This field is used only if you answered yes to the product costing question in the PDM Questionnaire.

AMEU43—Product Structure File Maintenance (Batch Status)

Use this display to review the status of the Product Structure file and of the batch to which you are currently attached.

This display appears when you select a closed, suspended, or active batch on display AMEUA1, or if you select **F24 (Status)** on display AMEU41.

```

DATE **/**/**      PRODUCT STRUCTURE FILE MAINTENANCE      BATCH STATUS AMEU43  **
                                     BATCH STATISTICS                                     BATCH ***
ADDs ENTERED                *****
CHANGES ENTERED            *****
DELETES ENTERED             *****
SAME-AS-EXCEPTS          ***
MASS REPLACES               ***
MASS DELETES                ***
STRUCTURE DELETES           ***
ADDs GENERATED             *****
CHANGES GENERATED         *****
DELETES GENERATED          *****

TOTAL TRANSACTIONS         *****

QUANTITY TOTAL  *,***,***,***.***

                                     F04 UPDATE NOW
                                     F20 DELETE BATCH
                                     F23 SUSPEND BATCH
                                     F24 CLOSE BATCH
    
```

What to do

- To close the batch and update the batch immediately, use **F04**. Your work station is not available until the update is complete. PDM schedules the reports for printing.
- To delete the batch, use **F20**. You must use **F20** twice to confirm the delete. PDM schedules the reports for printing.
- To suspend the batch, use **F23**.
- To close the batch and schedule a job to update the batch, use **F24**. PDM schedules the reports for printing.

The File Maintenance menu (AMEM05) appears again.

Function keys

You should suspend the batch using **F23** and update the Product Structure file at a later time to avoid conflicts with any other jobs.

F04 UPDATE NOW closes the batch and processes it immediately for update to the Product Structure file. Your work station is attached to the Product Structure File Load and Maintenance program (AMEB1) until completion of all updates. Upon completion, the File Maintenance menu (AMEM05) appears again.

F20 DELETE BATCH schedules a job to delete the batch and causes the File Maintenance menu (AMEM05) to appear again.

Use **F20** again to confirm the batch deletion.

F23 SUSPEND BATCH suspends your batch and causes the File Maintenance menu (AMEM05) to appear again.

Note: You should suspend the batch using **F23** and update the Product Structure file at a later time to avoid conflicts with any other jobs.

F24 CLOSE BATCH schedules a job to process the closed batch and causes the File Maintenance menu (AMEM05) to appear again.

Fields

See “AMEU18—Product Structure File Maintenance (Batch Status)” for descriptions of the fields on this display.

SEQ (User Sequence) (USRSQ). The user-designated sequence number of the component used to establish the sequence of the bills of material. This field appears only if the user sequence function was chosen during application tailoring.

COMPONENT ITEM (CINBR). The item number of each component of the parent item.

DESCRIPTION-TRUNC. (ITDSC). A description of the component that normally appears on invoices, inquiries, and reports.

QTY PER (Quantity Per) (QTYPR). The quantity of the component item used in the production of a standard batch quantity of the parent item.

UM (Unit of Measure) (UNMSR). The code (user-assigned) that identifies the measurement basis for onhand quantity and issue quantity for this item; for example, EA (each), KG (kilogram), or CM (centimeter).

IT (Item Type Code) (ITTYP).

0	Phantom
1	Assembly or subassembly
2	Fabricated item
3	Raw material
4	Purchased item
9	User option
F	Feature
K	Kit

BATCH. The batch number of each transaction.

TRN TYP (Transaction Type) (TTYPE). The type of transaction for each component.

ADD	Add, SAE header, or SAE add
CHG	Change, mass replace, or SAE change.

Option 3. Production Facility (AMEM05)

Use this option anytime you want to do one of the following:

- Add a new facility to the Production Facility file
- Change or delete a facility already in the file
- Change cost information for multiple facilities
- Make temporary changes to the capacity of an applicable facility.

Notes:

1. You can maintain production facility information in the Production Facility file if only the Production Facility file was selected during application tailoring.
2. Action 5 appears on the display only if REP or CRP is interfacing, and you are maintaining information using PDM, CRP, or REP file maintenance.
3. Variable capacity information can apply only to work centers or production lines.

What information you need:

- Facility ID
- Facility description
- Start date (for variable capacity maintenance)
- Number of days (for variable capacity maintenance).

What reports are printed: One or two of the following reports are printed, depending on the option you choose:

- Production Facility Maintenance (AMVT7)
- Variable Capacity Master File Maintenance (AMVTC).

What forms you need:

- Production Facility File Maintenance —PM-23
- Variable Capacity Master File Maintenance—TM-01.

AMVT70—Production Facility Maintenance (Select)

Use this display to type the ID of the production facility you want to make changes to and select the action you want to take.

This display appears when you select option 3 on the PDM File Maintenance menu (AMEM05), option 5 on the PM&C File Maintenance menu (AMJM50), option 5 on the PCC File Maintenance menu (AMCM70), option 4 on the REP File Maintenance menu (AMQM50), or option 4 on the CRP Planning Run Control menu (AMTM10).

```

DATE **/**/**      PRODUCTION FACILITY MAINTENANCE      SELECT      AMVT70  **

                                     ENTER--
                                     FACILITY ID   aaaA5
                                     ACTION         A

SELECT ONE OF THESE ACTIONS
1 ADD
2 CHANGE
3 DELETE
4 PERCENT CHANGE OF COST RATES
5 VARIABLE CAPACITY

                                     F23 STATUS
                                     F24 END OF JOB
    
```

What to do

- To select a production facility and the type of maintenance you want to perform, type in the requested information and press **Enter**. Go to one of the following displays, depending on which type of maintenance you selected:

Action	Display
1 (Add)	AMVT71
2 (Change)	AMVT72
3 (Delete)	AMVT73
4 (Percent change)	AMVT74
5 (Variable capacity)	AMVTC1

- To review the status of or end the session, use **F23**. Go to display AMVT75.
- To end the session and schedule the Production Facility Maintenance report (AMVT7) and the Production Facility Percent Change Audit report (AMET8) for printing, use **F24**.

Function keys

F23 STATUS causes the Production Facility Maintenance (Status) display (AMVT75) to appear.

F24 END OF JOB ends the session and schedules the reports to be printed. The menu appears again.

Fields

[?] appears next to a field name in the following field definitions to identify a field from which you can begin a master file search.

FACILITY ID (WKCTR) [?]. Required except for Action 4. Type in a facility ID for all actions except 4.

ACTION. Required. Select and type in one of the following action codes:

- 1 Add a facility record.
- 2 Change a facility record.
- 3 Delete a facility record.
- 4 Change cost rate percentages.
- 5 Maintain Variable Capacity information.

Use option 5 only if REP or CRP is installed.

AMVT71—Production Facility Maintenance (Add)

Use this display to add production facility records to the Production Facility file.

This display appears when you type in a facility ID and select action 1 (add) on display AMVT70.

```

DATE **/**/**      PRODUCTION FACILITY MAINTENANCE      ADD      AMVT71  **
FACILITY ID *****      FACILITY TYPE A      *****
DESCRIPTION aaaaaaaaaaaaaaaaaaaaaaaaaaaaaaaaaaaaaA40

DEPARTMENT          aaA4  PN FAC ACTG CLS          aA3  QUEUE TIME-DAYS      nn.nn
FOREMAN             aaA3  PRIME LOAD CODE        A    AVG QUEUE TIME      nnnnn.nn
LOCATION             aaaA5  TRACKING SIGNAL        nnnnn.nn  QUEUE MAD          nnnnn.nn
STD EFFICIENCY      n.nn  AVG STD OUTPUT         nnnnn.nn  MACH RESOURCE NO.  aaaA5
AVG EFFICIENCY      n.nn  AVG ACTL OUTPUT        nnnnn.nn  LABOR RESOURCE NO. aaaA5
EXTRACT MACH BRKS   A    REPORTING METHOD        n    CLOCKING WINDOW    n:nn

                MACHINE      RUN LABOR      SETUP LABOR      OVERHEAD      OVERHEAD
                RATE        RATE          RATE            RATE/PERCENT  CODE
CURRENT          nnnnn.nn  nnnnn.nn      nnnnn.nn        nnnnn.nn      A
STANDARD         nnnnn.nn  nnnnn.nn      nnnnn.nn        nnnnn.nn      A

      -----LENGTH-----      -----CAPACITY-----
      DESIRED  MAXIMUM      DESIRED  MAXIMUM
SHIFT 1  nn.n  nn.n      nn.n  nn.n      CALENDAR ID  aaaaaaA10
      POST TO OLDEST SCHED  A

SHIFT 2  nn.n  nn.n      nn.n  nn.n      POST TO FUTURE SCHED  A
SHIFT 3  nn.n  nn.n      nn.n  nn.n      FACILITY STOCK LOC aaaaaA7
      F19 RETURN TO SELECT
  
```

What to do

To add a production facility to the Production Facility file, type in the information requested and press **Enter**. Go to display AMVT70.

Function keys

F19 RETURN TO SELECT ignores any data you typed in and causes display AMVT70 to appear again.

Fields

[?] appears next to a field name in the following field definitions to identify a field from which you can begin a master file search.

Fields that show historical statistics are updated by Production Control and Costing (PC&C), if it is installed and interfacing.

Three queue statistics (average queue time, queue MAD, and tracking signal) are updated every time PC&C prints the Production Facility Analysis report, when PC&C closes out and purges an order, or when work list generation is run.

Three output statistics (average standard output, average efficiency, and average actual output) can be updated when PC&C closes out and purges orders.

FACILITY ID (WKCTR). The ID of the facility you are adding to the Production Facility file. If the time basis code is C, this ID represents a vendor (or group of vendors).

FACILITY TYPE (WLNCD). This field appears only if REP is installed. Type a code that indicates the kind of information you are adding:

- blank** Work center
- 1** Production line
- 2** Work station.

Facility Type Description. This field has no heading and appears to the immediate right of **FACILITY TYPE**. It contains a verbal description of the code in the **FACILITY TYPE** field, such as **WORK CENTER**, **WORK STATION**, or **PRODUCTION LINE**.

DESCRIPTION (WCDSC). Required. Type in a description of the production facility.

DEPARTMENT (DEPNO). Type in the department where this facility is located. If Payroll is installed and interfacing, this number should correspond to the department in Payroll's Labor Distribution file.

Note: A single department can have multiple facilities.

PN FAC ACTG CLS (PFAC). Class, defined by your company, to group or classify orders or items by production facility for accounting purposes.

QUEUE TIME-DAYS (STDQT). Type in the expected number of days a job waits in the queue at this facility before work begins on it.

FOREMAN (FRMAN). Type in the code that identifies the foreman for this facility.

PRIME LOAD CODE (PLOAD). Type in the prime load code for this facility. The prime load code is used to calculate the duration of the operation for PC&C and CRP scheduling routines. It identifies the critical (constraining) operation time factors necessary to schedule each operation's due date from its operation start date. The valid codes are:

- 0** No hours accumulated
- 1** Run machine hours
- 2** Setup labor hours divided by setup crew size
- 3** (Setup labor hours divided by setup crew size) + run machine hours
- 4** Run labor hours
- 5** (Setup labor hours divided by setup crew size) + run labor hours

AVG QUEUE TIME (Average Queue Time) (AVGQT). Type in the average total standard hours of work in the queue at this facility.

LOCATION (WCLOC). Type in the code that indicates the location of the facility. If the time basis code is C, this is the location of the vendor.

TRACKING SIGNAL (TRSIG). Type in the tracking signal for this facility. The tracking signal, which is used by PC&C, is the sum of the differences of current queue time from old average queue time that is calculated with each running of the Production Facility Analysis report.

QUEUE MAD (QUEUE MEAN ABSOLUTE DEVIATION) (WQMAD). Type in the average difference of the queue at this facility. The queue mean absolute deviation, which is used by PC&C, is an average of the differences between the current queue within a facility and the old average queue of that facility. This shows how much the queue fluctuates in the facility.

Note: A negative amount is made positive when you press **Enter**.

STD EFFICIENCY (Standard Efficiency) (STDEF). Type in the standard efficiency of the facility. It should reflect the expected value of average actual output divided by average standard output.

Note: A negative amount is made positive when you press **Enter**.

AVG STD OUTPUT (Average Standard Output) (AVGSO). Type in the average standard output of this facility. The average standard output is an average of the standard time (hours) produced per day per period (PC&C order close out) at a facility. The standard hours are based on standard times from the detail operations performed in the facility.

Note: A negative amount is made positive when you press **Enter**.

MACH RESOURCE NO. (MACRN) [?]. Type in the resource number used by MPSP (if installed and interfacing) to identify machine hours in this facility as a critical resource; for example, a machine that affects major work flow in a facility. If MPSP is not installed, leave this field blank or type in **0** (zero).

Note: You must enter the machine resource number in the MPSP Resource Master file before you can enter it into the Production Facility file.

AVG EFFICIENCY (Average Efficiency) (AVGEF). Type in the average efficiency of this facility. The average efficiency is the average of the actual hours worked per day for this period divided by the average standard output per day for this period.

Note: A negative amount is made positive when you press **Enter**.

AVG ACTL OUTPUT (Average Actual Output) (AVGAO). Type in the average actual output of this facility. The average actual output is the average of the actual time (hours) worked per day for this period (PC&C order close out) at a facility.

Note: A negative amount is made positive when you press **Enter**.

LABOR RESOURCE NO. (LABRN) [?]. Type in the resource number used by MPSP (if installed and interfacing) to identify labor hours in this facility as a critical resource. For example, a facility with limited available labor hours because of workers with special skills. If MPSP is not installed, leave this field blank or type in **0** (zero).

Note: You must enter the Labor Resource Number in the MPSP Resource Master file before you can enter it into the Production Facility file.

EXTRACT MACH BRKS (BRKXT) <1/0>. Required. Type in the letter that indicates to the PM&C application whether you want to extract break time from machine hours. The valid entries are:

- 1** Extract break time.
- 0** Do not extract break time.

Only the standard rates of the following five fields are discussed. The other fields are the same except that current rates are used.

REPORTING METHOD. Type in the method used at the facility for reporting job transactions in PM&C. The values for the methods are:

- 0** ON/OF reporting. Both ON (On) and OF (Off) transactions are required for each job. Jobs completed without both transactions are flagged as errors.
- 1** Off-Only reporting with full ON override. OF transactions are required for each job. ON transactions are optional. If a job starts with an ON transaction, all information is used from the ON transaction. If an ON transaction does not

exist, start times for the job are calculated from previous OF and T/A transactions. All other information is used from the OF transaction.

- 2 Off-Only reporting with ON facility ID override. OF transactions are required for each job. ON transactions are optional. If the job starts with an ON transaction, the only information used from the ON transaction is the facility ID. All other information is used from the OF transaction. Start times are always calculated from previous OF and T/A transactions (even if an ON transaction exists).

CLOCKING WINDOW. The clocking window time defined in PM&C for facilities using off-only reporting to group jobs that run concurrently and apportion time among those jobs. If the facility uses off-only reporting and jobs are run concurrently by the same employee, type in a clocking window time. The system groups jobs that have OF transactions spaced equal to or less than the clocking window time and apportions the time among them. For example, if you set the clocking window to 5:00 (five minutes) and OF transactions occur at 10:00:00, 10:03:00, and 10:06:00 (less than five minutes apart), the system treats the group as if they were started and completed at the same time and apportions the time among them.

The time can be any value from 0:00 to 9:59 (one second less than ten minutes). Use the default time (0:00) to have the jobs treated as if they were run consecutively.

CURRENT STANDARD.

MACHINE RATE (CMACH or SMACH): This rate, in cost per hour, is used with the run machine field of the associated routing to calculate the run machine cost. If the time basis code is C, this field should be zero. PDM product costing also uses this value to calculate labor overhead content this-level in the associated Item Master B-records.

RUN LABOR RATE (CRLAB or SRLAB): This rate, in cost per hour, is used with the run labor field of the associated routing to calculate the run labor cost. PDM product costing also uses this value to calculate standard labor and labor overhead content this-level in the associated Item Master B-records. This field is not used in calculating run labor costs for routing operations with time basis code = C (outside operation).

SETUP LABOR RATE (CSLAB or SSLAB): This rate, in cost per hour, is used with the setup labor hours field of the associated routing to calculate the setup labor cost. If the time basis code is C, this field should be zero in most cases. PDM product costing also uses this value to calculate labor and labor overhead content this-level in the associated Item Master B-records.

OVERHEAD RATE/PERCENT (COVER or SOVER): The labor overhead rate or percent is used in the labor overhead calculation of PDM costing formulas based on the labor overhead code (COCOD or SOCOD) you enter. If the time basis code is C, this field should be zero.

OVERHEAD CODE (SOCOD): This code indicates which of four methods (A, B, C, or D) is used to calculate standard labor overhead this level in the associated Item Master B-records. If the time basis code is C, this field should be blank. PDM product costing must be installed and interfacing, and the cost technique code in associated Item Master B-records must be R if this code is used.

Note: A negative amount is made positive when you press **Enter**.

SHIFT LENGTH. If this is a production line, at least one shift length is required.

DESIRED (DLEN1, DLEN2, DLEN3): These fields, which are used in scheduling calculations, show the number of prime load code hours normally available for the duration of shifts 1, 2, or 3 for this facility.

MAXIMUM (MLEN1, MLEN2, MLEN3): These fields show the maximum number of prime load code hours available for the duration of shifts 1, 2, or 3 for this facility.

Note: A negative amount is made positive when you press **Enter**.

SHIFT CAPACITY.

DESIRED (DCAP1, DCAP2, DCAP3): These fields, which are used in scheduling calculations, show the number of workers or machines (whichever is the critical resource) normally scheduled at this facility during shifts 1, 2, or 3.

MAXIMUM (MCAP1, MCAP2, MCAP3): These fields show the maximum number of workers or machines that can be scheduled at this facility during shifts 1, 2, or 3.

Note: A negative amount is made positive when you press **Enter**.

CALENDAR ID (CALN) [?]. The identifier of the production calendar associated with this facility. This field is used by REP to explicitly define the days a production line is available for work.

POST TO OLDEST SCHED (APSQ). Appears if REP is interfacing. Type a code that indicates how you want to apply RM, RO, and SM transaction quantities. The valid codes are:

blank Defaults to the setting in the REPCTL record.

0 Off, posting is by individual schedules for all items on this production line.

1 On, multi-schedule posting, beginning with the oldest schedule, is used for all items on this production line.

POST TO FUTURE SCHED (APTQ). Appears if REP is interfacing. Type a code that indicates how you want to apply RM, RO, and SM transaction quantities. The valid codes are:

blank Defaults to the setting in the REPCTL record.

0 Off, post to past and current schedules on this production line.

1 On, post to past, current, and future schedules on this production line.

FACILITY STOCK LOC (FSLC). If the facility is a workstation, this field represents the line location where items are delivered and used in a production line operation. If the facility is a production line, then this field represents the stocking location where finished goods are stored. This field is used by REP as a default line location when setting up the Item-Line definition for a schedule controlled item.

AMVT72—Production Facility Maintenance (Change)

Use this display to change an existing production facility record in the Production Facility file.

This display appears when you type in a valid facility ID and select action 2 (change) on display AMVT70.

```

DATE **/**/**      PRODUCTION FACILITY MAINTENANCE      CHANGE      AMVT72  **
FACILITY ID *****      FACILITY TYPE A      *****
DESCRIPTION aaaaaaaaaaaaaaaaaaaaaaaaaaaaaaaaaaaaaA40

DEPARTMENT      aaA4      PN FAC ACTG CLS      aA3      QUEUE TIME-DAYS      nn.nn
FOREMAN          aA3      PRIME LOAD CODE      A      AVG QUEUE TIME      nnnnn.nn
LOCATION          aaaaA5      TRACKING SIGNAL      nnnnn.nn      QUEUE MAD      nnnnn.nn
STD EFFICIENCY  n.nn      AVG STD OUTPUT      nnnnn.nn      MACH RESOURCE NO.  aaaaA5
AVG EFFICIENCY  n.nn      AVG ACTL OUTPUT      nnnnn.nn      LABOR RESOURCE NO. aaaaA5
EXTRACT MACH BRKS  A      REPORTING METHOD      n      CLOCKING WINDOW      n:nn

MACHINE      RUN LABOR      SETUP LABOR      OVERHEAD      OVERHEAD
RATE          RATE          RATE          RATE/PERCENT  CODE
CURRENT      nnnnn.nn      nnnnn.nn      nnnnn.nn      nnnnn.nn      A
STANDARD     nnnnn.nn      nnnnn.nn      nnnnn.nn      nnnnn.nn      A

-----LENGTH-----      -----CAPACITY-----
DESIRED  MAXIMUM  DESIRED  MAXIMUM  CALENDAR ID      aaaaaA10
SHIFT 1  nn.n    nn.n    nn.n    nn.n    POST TO OLDEST SCHED  A
SHIFT 2  nn.n    nn.n    nn.n    nn.n    POST TO FUTURE SCHED  A
SHIFT 3  nn.n    nn.n    nn.n    nn.n    FACILITY STOCK LOC aaaaaA7
F18 REFRESH SCREEN
F19 RETURN TO SELECT

```

What to do

To change a production facility record, type in the information you want to change and press **Enter**. Go to display AMVT70.

Function keys

F18 REFRESH SCREEN erases any data you typed in and shows AMVT72 as it first appeared.

F19 RETURN TO SELECT ignores any data you typed in and causes display AMVT70 to appear again.

Fields

Any of the fields, except **FACILITY ID**, entered using display AMVT71 can be changed using this display. For descriptions of these fields, see “AMVT71—Production Facility Maintenance (Add)”.

AMVT73—Production Facility Maintenance (Delete)

Use this display to delete a production facility record from the Production Facility file.

This display appears when you type in a valid facility ID and select action 3 (delete) on display AMVT70.

```

DATE **/**/**      PRODUCTION FACILITY MAINTENANCE      DELETE      AMVT73  **
FACILITY ID *****      FACILITY TYPE *      *****
DESCRIPTION *****
DEPARTMENT      ****      PN FAC ACTG CLS      ***      QUEUE TIME-DAYS      **. **
FOREMAN      ***      PRIME LOAD CODE      *      AVG QUEUE TIME      ***** **
LOCATION      *****      TRACKING SIGNAL      ***** **      QUEUE MAD      ***** **
STD EFFICIENCY      *. **      AVG STD OUTPUT      ***** **      MACH RESOURCE NO.      *****
AVG EFFICIENCY      *. **      AVG ACTL OUTPUT      ***** **      LABOR RESOURCE NO.      *****
EXTRACT MACH BRKS      *      REPORTING METHOD      *      CLOCKING WINDOW      *: **

MACHINE      RUN LABOR      SETUP LABOR      OVERHEAD      OVERHEAD
RATE      RATE      RATE      RATE/PERCENT      CODE
CURRENT      **, **., **      **, **., **      **, **., **      **, **., **      *
STANDARD      **, **., **      **, **., **      **, **., **      **, **., **      *

-----LENGTH-----      -----CAPACITY-----
DESIRED      MAXIMUM      DESIRED      MAXIMUM      CALENDAR ID      *****
SHIFT 1      **, *      **, *      **, *      **, *      POST TO OLDEST SCHED      *
SHIFT 2      **, *      **, *      **, *      **, *      POST TO FUTURE SCHED      *
SHIFT 3      **, *      **, *      **, *      **, *      FACILITY STOCK LOC *****
P R E S S      E N T E R      T O      D E L E T E      F19 RETURN TO SELECT

```

What to do

To delete a production facility from the Production Facility file, press **Enter**. The record is flagged for deletion. Go to display AMVT70.

Function keys

F19 RETURN TO SELECT does not delete the record and causes display AMVT70 to appear again.

Fields

All of the fields on this display are informational only. For descriptions of the fields on this display, see “AMVT71—Production Facility Maintenance (Add)”.

AMVT74—Production Facility Maintenance (Change)

Use this display to change cost information for multiple production facility records in the Production Facility file.

This display appears when you type in a valid facility ID and select action 4 (percent change of cost rates) on display AMVT70.

You can select the rate you want to change (setup labor, run labor, machine labor, or labor overhead—current and/or standard) and the percent change you want to use. Only one percent change (the last one you entered if you entered more than one) is processed at a time.

```

DATE **/**/**          PRODUCTION FACILITY MAINTENANCE          CHANG%  AMVT74  **

                                     ENTER--
                                     RATE TYPE    n
                                     % CHANGE     nnn.nn
SELECT ONE OF THESE RATE TYPES      COST TYPE    A
1 SETUP LABOR RATE
2 RUN LABOR RATE
3 MACHINE RATE
4 OVERHEAD RATE/PERCENT

SELECT ONE OF THESE COST TYPES
C CURRENT
S STANDARD
B BOTH

                                     F19 RETURN TO SELECT
    
```

What to do

To change cost information for multiple production facility records, type in the information requested and press **Enter**. The percent change you entered is applied to the rate you selected when the session ends. Go to display AMVT70.

Function keys

F19 RETURN TO SELECT ignores the data you just entered and causes display AMVT70 to appear again.

Fields

RATE TYPE. Required. Type in one of the following rate types:

- 1 Setup Labor Rate
- 2 Run Labor Rate
- 3 Machine Rate
- 4 Overhead Rate/Percent.

% CHANGE. Required. Type in the percent change you are applying to the selected rate. The percent change is the difference between the current rate and the target rate, divided by the current rate. Use a positive value to increase the current rate or a negative value to decrease it.

Only one percent change (the last one you entered if you entered more than one) is processed at a time.

COST TYPE. Required. Type in one of the following cost types:

- C Current
- S Standard
- B Both.

AMVT75—Production Facility Maintenance (Status)

This display appears when you use **F23** on the Select display (AMVT70). The Production Facility Maintenance Control Sheet prints after you update the Production Facility file using file maintenance.

The following statistics should be the same on the display and the report:

1. Maintenance number and update number
2. Adds entered and facilities added
3. Changes entered and facilities changed
4. Deletes entered and facilities deleted.

DATE **/**/**	PRODUCTION FACILITY MAINTENANCE	STATUS	AMVT75 **
SESSION STATISTICS			
[1]	MAINTENANCE NUMBER	10	
[2]	ADDS ENTERED	1	
[3]	CHANGES ENTERED	1	
[4]	DELETES ENTERED	1	
	TOTAL TRANSACTIONS	3	
F24 END OF JOB			

What to do

- To end the session and schedule the Production Facility Maintenance report (AMVT7) for printing, use **F24**. The menu appears again.
- To return to the previous display, press **Enter**.

Function keys

F24 END OF JOB causes the menu to appear again.

Fields

All of the fields on this display are informational.

SESSION STATISTICS. These fields show the statistics for the current file maintenance session

MAINTENANCE NUMBER: The number assigned to this session.

ADDS ENTERED: The number of records added.

[Contents](#)

[Index](#)

CHANGES ENTERED: The number of records changed.

DELETES ENTERED: The number of records deleted.

TOTAL TRANSACTIONS: The total number of transactions (adds, changes, and deletes) for this file maintenance session.

AMVTC1—Variable Capacity Maintenance (Select)

Use this display to select a facility and the type of maintenance to be performed on its variable capacity records.

This display appears when you select option 2 on CRP menu AMTM10, or when you select action 5 on the Production Facility Maintenance (Select) display (AMVT70) or when you use **F19** (Return to Select) on displays AMVTC2, AMVTC3, AMVTC4, or AMVTC5.

If EPDM is activated, this display and the following displays are disabled in PDM and CRP. If you try to access these displays, you will receive an error message.

Note: This display appears only if CRP is installed and interfacing.

```

DATE **/**/**          VARIABLE CAPACITY MAINTENANCE          SELECT          AMVTC1  **

ENTER:  ACTION              A
        SITE                aA3
        FACILITY ID         aaaA5
        START DATE (OPTIONAL) nnnnnn
        RECORDS TO REVIEW   A

SELECT ONE OF THESE ACTIONS:
1 - ADD
2 - CHANGE
3 - DELETE
9 - DELETE ALL PRODUCTION FACILITY VARIABLE CAPACITY

SELECT TYPE OF RECORDS TO REVIEW DURING MAINTENANCE:
1 - REVIEW SHIFT LENGTH CHANGE RECORDS ONLY
2 - REVIEW RESOURCE CHANGE RECORDS ONLY
3 - REVIEW ALL VARIABLE CAPACITY RECORDS

F23 DISPLAY STATUS
    
```

What to do

- To select a production facility and the type of maintenance you want to perform on the variable capacity records, type in the requested information and press **Enter**. Go to one of the following displays, depending on which type of maintenance you selected:

Action	Display
1 (Add)	AMVTC2
2 (Change)	AMVTC3
3 (Delete)	AMVTC4
9 (Delete all))	AMVTC5

Note: **FACILITY ID**, as used in field descriptions for variable capacity maintenance, refers to both production lines and work centers if Repetitive Production Management (REP) is installed and interfacing. Otherwise, it refers to work centers only.

- To review the status of and end the session, use **F23**.

Function keys

F23 DISPLAY STATUS causes the Variable Capacity Maintenance (Status) display (AMVTC6) to appear.

Fields

[?] appears next to a field name in the following field definitions to identify a field from which you can begin a master file search.

ACTION (ACTON). Required. Select and type in one of the following actions:

- 1 Add
- 2 Change
- 3 Delete
- 9 Delete all production facility variable capacity.

SITE (STID) [?]. Type in the site identifier for the production facility to be maintained. This field appears only if EPDM is activated.

FACILITY ID (WKCTR) [?]. Required. Type in the ID of the production facility to be maintained.

START DATE (STDAT). This field allows you to type in the date that the review is to begin. If no date is entered, the earliest variable capacity start date is used.

RECORDS TO REVIEW (INCLU). Required. This field allows you to specify the type of records to be reviewed for possible maintenance.

Type in one of the following numbers:

- 1 Review shift length change records only.
- 2 Review resource change records only.
- 3 Review all variable capacity records.

AMVTC2—Variable Capacity Maintenance (Add)

Use this display to add variable capacity records for work centers or production lines. (You can work with production lines only if Repetitive Production Management is installed and interfacing.)

This display appears when you select action A (Add) on the Variable Capacity Maintenance (Select) display (AMVTC1) or when you use **F04 (Add)** on either display AMVTC3 or AMVTC4.

```

DATE **/**/**          VARIABLE CAPACITY MAINTENANCE      ADD      AMVTC2  **
SITE ***

*****  *****  DESCRIPTION *****

      START NBR  -SHIFT LENGTH-  -RESOURCE UNITS-
      DATE  DAYS  1    2    3    1    2    3  SOURCE DESCRIPTION
- TOP OF DATA -  **.* **.* **.* **.* **.* **.* **.* ***** BASE VALUES
**/**/** ** **.* **.* **.* **.* **.* **.* **.* *****
**/**/** ** **.* **.* **.* **.* **.* **.* **.* *****
**/**/** ** **.* **.* **.* **.* **.* **.* **.* *****
**/**/** ** **.* **.* **.* **.* **.* **.* **.* *****
**/**/** ** **.* **.* **.* **.* **.* **.* **.* *****
**/**/** ** **.* **.* **.* **.* **.* **.* **.* *****
**/**/** ** **.* **.* **.* **.* **.* **.* **.* *****
**/**/** ** **.* **.* **.* **.* **.* **.* **.* *****
      ONLY RECORDS WITH ***** CHANGES SHOWN

ADD RECORD
START DATE      nnnnnn
NUMBER OF DAYS  nn      SHIFT 1  SHIFT 2  SHIFT 3  USE ROLL UP/DOWN
NEW SHIFT LENGTH      nn.n      nn.n      nn.n      F01 RESTART FACILITY
INCREMENTAL RESOURCE  nn.n-     nn.n-     nn.n-     F05 CHANGE RECORDS
SOURCE DESCRIPTION    aaaaaaaaaaaaaaaaaaaaaA25  F06 DELETE RECORDS
                                                           F19 RETURN TO SELECT
                                                           F23 DISPLAY STATUS
    
```

What to do

- To add a variable capacity record, type in the information requested and press **Enter**. The record you just added is shown on the top half of the display.
- To see the variable capacity records for the production facility from the beginning, use **F01**.
- To change a variable capacity record for a production facility, use **F05**. Go to display AMVTC3.
- To delete a variable capacity record for a production facility, use **F06**. Go to display AMVTC4.
- To review the status of and end the session, use **F23**. Go to display AMVTC6.

Function keys

USE ROLL UP/DOWN allows you to scroll forward and backward through the variable capacity records associated with this facility if the word CONTINUED appears. If END OF DATA appears, no additional records exist and the first page of records is shown.

F01 RESTART FACILITY shows all variable capacity records for this facility starting with the first based on the Include for Review code entered on Select display AMVTC1.

F05 CHANGE RECORDS causes the Variable Capacity Maintenance (Change) display (AMVTC3) to appear.

F06 DELETE RECORDS causes the Variable Capacity Maintenance (Delete) display (AMVTC4) to appear.

F19 RETURN TO SELECT causes the Variable Capacity Maintenance (Select) display (AMVTC1) to appear.

F23 DISPLAY STATUS causes the Variable Capacity Maintenance (Status) display (AMVTC6) to appear.

Fields

[?] appears next to a field name in the following field definitions to identify a field from which you can begin a master file search.

SITE (STID). This field contains the site identifier of the facility. This field appears only if EPDM is activated.

Facility Identifier (WKCTR). This field appears below the date and site, without a heading, and contains the ID of the facility you entered on display AMVTC1. If the facility is a work center, the field heading is WORK CENTER ID; otherwise the heading is PRODUCTION LINE.

DESCRIPTION (WCDSC). This field contains the description of the facility.

START DATE (VDATE). This field contains the date the variable capacity is due to start.

NBR DAYS (Number of Days) (VDAYS). This field contains the number of days this resource (workers or machines) is available.

A total of 99 days indicates indefinite resource availability over the planning horizon.

SHIFT LENGTH (HOURS) (VLEN1, VLEN2, VLEN3). These fields contain the length in hours of up to three shifts.

RESOURCE UNITS (MEN/MACHINES) (VCAP1, VCAP2, VCAP3). These fields contain the number of resource units available for each of the three shifts.

SOURCE DESCRIPTION (VDESC). This field contains a description of the variable capacity add record; for example, scheduled overtime.

***** **BASE VALUES**. If this facility is a work center, the heading for this field is WORK CENTER BASE VALUES. Otherwise, the heading is PRODUCTION LINE BASE VALUES.

The base values (shift lengths and resource units) for this facility are shown on the line just above the first variable capacity record. These are the values for this facility from the Production Facility file.

START DATE (STDAT). Required. Type in the date that this variable capacity is to begin.

NUMBER OF DAYS (VDAYS). Required. Type in the number of days that this variable capacity change is to be effective.

Typing in **99** signifies indefinite resource over the planning horizon.

NEW SHIFT LENGTH (HOURS) (NLEN1, NLEN2, NLEN3). Required if you do not use the **INCREMENTAL RESOURCE** field. Type in the number of hours available during each shift for up to three shifts. The number of hours you enter here is used as a replacement value for the base shift length.

Note: The start date and duration of this shift length may not overlap the shift length in any other variable capacity record.

INCREMENTAL RESOURCE (MEN/MACHINES) (NCAP1, NCAP2, NCAP3). Required if you do not use the **NEW SHIFT LENGTH** field. Type in the number of additional resource units above or below the base capacity for this resource. The number you enter here is used to increment (add to or subtract from) the base incremental resource.

Resource units are expressed in shift length increments such that each resource unit is understood to be working the entire shift; for example, if shift length is 8 hours and you want to add one resource unit for 4 hours, you would type in **5** to indicate 0.5 resource units.

To reduce the number of resource units for a certain time period due to vacation or down time, type in a value and press the **FIELD - (minus)** key.

Note: The start date and duration of a negative incremental resource may not allow shift capacity to become negative during this period.

SOURCE DESCRIPTION (NDESC). Type in a description of this variable capacity change; for example, "scheduled overtime," "add one employee," or "operator on vacation."

AMVTC3—Variable Capacity Maintenance (Change)

Use this display to change variable capacity records for a facility.

This display appears when you select action 2 (Change) on the Variable Capacity Maintenance (Select) display (AMVTC1) or when you use **F05 (Change)** on either display AMVTC2 or AMVTC4.

When this display first appears, the bottom half is blank except for the function keys and the **ENTER CHANGE REFERENCE NUMBER** field. When you type in a change reference number and press **Enter**, the record you want to change appears on the bottom half of the display.

DATE **/**/**	VARIABLE CAPACITY MAINTENANCE	CHANGE	AMVTC3 **
SITE ***			
***** DESCRIPTION *****			
REF	START NBR	-SHIFT LENGTH-	-RESOURCE UNITS-
NBR	DATE	DAYS	1 2 3 1 2 3
			SOURCE DESCRIPTION
- TOP OF DATA -	**.*	**.*	**.* **.* **.* **.*
* **/**/**	**	**.*	**.* **.* **.* **.* **.*
* **/**/**	**	**.*	**.* **.* **.* **.* **.*
* **/**/**	**	**.*	**.* **.* **.* **.* **.*
* **/**/**	**	**.*	**.* **.* **.* **.* **.*
* **/**/**	**	**.*	**.* **.* **.* **.* **.*
* **/**/**	**	**.*	**.* **.* **.* **.* **.*
* **/**/**	**	**.*	**.* **.* **.* **.* **.*
* **/**/**	**	**.*	**.* **.* **.* **.* **.*

ENTER CHANGE REFERENCE NUMBER n			
USE ROLL UP/DOWN			
F01 RESTART FACILITY			
F04 ADD RECORDS			
F06 DELETE RECORDS			
F19 RETURN TO SELECT			
F23 DISPLAY STATUS			

*-CHANGE RECORD				
START DATE	nnnnnn			
NUMBER OF DAYS	nn	SHIFT 1	SHIFT 2	SHIFT 3
NEW SHIFT LENGTH	nn.n	nn.n	nn.n	nn.n
INCREMENTAL RESOURCE	nn.n-	nn.n-	nn.n-	nn.n-
SOURCE DESCRIPTION	aaaaaaaaaaaaaaaaaaaaa	A25		
USE ROLL UP/DOWN				
F01 RESTART FACILITY				
F04 ADD RECORDS				
F06 DELETE RECORDS				
F19 RETURN TO SELECT				
F23 DISPLAY STATUS				

What to do

- To change a variable capacity record, type in a reference number and press **Enter**. The record associated with the reference number appears on the bottom half of the display. Type in the necessary changes for this record and press **Enter** again. The changed record appears on the top half of the display.
- To see the variable capacity records for the production facility from the beginning, use **F01**.
- To delete a variable capacity record for a production facility, use **F06**. Go to display AMVTC4.
- To review the status of and end the session, use **F23**. Go to display AMVTC6.

Function keys

USE ROLL UP/DOWN allows you to scroll forward and backward through the variable capacity records associated with this facility.

F01 RESTART FACILITY shows all variable capacity records for this facility starting with the first based on the Include for Review code entered on Select display AMVTC1.

F04 ADD RECORDS causes the Variable Capacity Maintenance (Add) display (AMVTC2) to appear.

F06 DELETE RECORDS causes the Variable Capacity Maintenance (Delete) display (AMVTC4) to appear.

F19 RETURN TO SELECT causes the Variable Capacity Maintenance (Select) display (AMVTC1) to appear.

F23 DISPLAY STATUS causes the Variable Capacity Maintenance (Status) display (AMVTC6) to appear.

Fields

SITE (STID). This field contains the site identifier of the facility. This field appears only if EPDM is activated.

REF NBR (Reference Number) (REFNO). This field contains an application-assigned number used to select a specific record to be changed or deleted.

ENTER CHANGE REFERENCE NUMBER. Type in the reference number of the variable capacity record you want to change and press **Enter**.

For a description of the other fields on this display, see "AMVTC2—Variable Capacity Maintenance (Add)".

AMVTC4—Variable Capacity Maintenance (Delete)

Use this display to delete an individual variable capacity record for a facility.

This display appears when you select action D (Delete) on the Variable Capacity Maintenance (Select) display (AMVTC1) or when you use **F06 (Delete)** on either display AMVTC2 or AMVTC3.

When this display first appears, the bottom half is blank except for the function keys and the **ENTER DELETE REFERENCE NUMBER** field. When you type in a delete reference number and press **Enter**, the record you want to delete appears on the bottom half of the display.

```

DATE **/**/**          VARIABLE CAPACITY MAINTENANCE      DELETE      AMVTC4  **
SITE ***

*****  *****  DESCRIPTION *****

REF  START  NBR  -SHIFT LENGTH- -RESOURCE UNITS-
NBR  DATE  DAYS  1    2    3    1    2    3    SOURCE DESCRIPTION
- TOP OF DATA -  **.* **.* **.* **.* **.* **.* **.* **.* **.* ***** BASE VALUES
* **/**/** ** **.* **.* **.* **.* **.* **.* **.* *****
* **/**/** ** **.* **.* **.* **.* **.* **.* **.* *****
* **/**/** ** **.* **.* **.* **.* **.* **.* **.* *****
* **/**/** ** **.* **.* **.* **.* **.* **.* **.* *****
* **/**/** ** **.* **.* **.* **.* **.* **.* **.* *****
* **/**/** ** **.* **.* **.* **.* **.* **.* **.* *****
* **/**/** ** **.* **.* **.* **.* **.* **.* **.* *****
* **/**/** ** **.* **.* **.* **.* **.* **.* **.* ***** +

ENTER DELETE REFERENCE NUMBER n

                                         USE ROLL UP/DOWN
                                         F01 RESTART FACILITY
                                         F04 ADD RECORDS
                                         F05 CHANGE RECORDS
                                         F19 RETURN TO SELECT
                                         F23 DISPLAY STATUS
    
```

```

*--DELETE RECORD
START DATE      *****
DAYS AVAILABLE  **
SOURCE DESCRIPTION *****

PRESS ENTER TO DELETE THIS VARIABLE CAPACITY

                                         USE ROLL UP/DOWN
                                         F01 RESTART FACILITY
                                         F04 ADD RECORDS
                                         F05 CHANGE RECORDS
                                         F19 RETURN TO SELECT
                                         F23 DISPLAY STATUS
    
```

What to do

- To delete a variable capacity record, type in a reference number and press **Enter**. The record associated with the reference number appears on the bottom half of the display. Press **Enter** again to flag the record for deletion. The flagged record appears on the top half of the display.
- To see the variable capacity records for the production facility from the beginning, use **F01**.
- To add a variable capacity record for a production facility, use **F04**. Go to display AMVTC2.

- To change a variable capacity record for a production facility, use **F05**. Go to display AMVTC3.
- To review the status of and end the session, use **F23**. Go to display AMVTC6.

Function keys

USE ROLL UP/DOWN allows you to scroll forward and backward through the variable capacity records associated with this facility.

F01 RESTART FACILITY shows all variable capacity records for this facility starting with the first based on the Include for Review code entered on Select Display AMVTC1.

F04 ADD RECORDS causes the Variable Capacity Maintenance (Add) display (AMVTC2) to appear.

F05 CHANGE RECORDS causes the Variable Capacity Maintenance (Change) display (AMVTC3) to appear.

F19 RETURN TO SELECT causes the Variable Capacity Maintenance (Select) display (AMVTC1) to appear.

F23 DISPLAY STATUS causes the Variable Capacity Maintenance (Status) display (AMVTC6) to appear.

Fields

SITE (STID). This field contains the site identifier of the facility. This field appears only if EPDM is activated.

REF NBR (Reference Number) (REFNO). This field contains an application-assigned number used to select a specific record to be changed or deleted.

ENTER DELETE REFERENCE NUMBER. Type in the reference number of the variable capacity record you want to delete.

For a description of the other information fields on the top half of this display, see "AMVTC2—Variable Capacity Maintenance (Add)".

AMVTC5—Variable Capacity Maintenance (Delete All)

Use this display to delete all of the variable capacity records for a facility.

This display appears when you select action 9 (Delete All) on the Variable Capacity Maintenance (Select) display (AMVTC1).

Note: Use **ROLL UP/DOWN** and **F01** to review the records for this facility. As a safeguard, it is necessary to press **Enter** twice before all variable capacity records for the facility are deleted. When you are satisfied that these variable capacity records are to be deleted, press **Enter**. Then, to delete all variable capacity records for this facility, press **Enter** again.

```

DATE **/**/**          VARIABLE CAPACITY MAINTENANCE          DELETE ALL AMVTC5  **
SITE ***

*****      *****      DESCRIPTION *****

      START  NBR  -SHIFT LENGTH-  -RESOURCE UNITS-
      DATE  DAYS   1    2    3      1    2    3  SOURCE DESCRIPTION
- TOP OF DATA -  **.* **.* **.* **.* **.*- **.*- **.*- **.*- ***** BASE VALUES
**/**/** **  **.* **.* **.* **.* **.*- **.*- **.*- **.*- *****
**/**/** **  **.* **.* **.* **.* **.*- **.*- **.*- **.*- *****
**/**/** **  **.* **.* **.* **.* **.*- **.*- **.*- **.*- *****
**/**/** **  **.* **.* **.* **.* **.*- **.*- **.*- **.*- *****
**/**/** **  **.* **.* **.* **.* **.*- **.*- **.*- **.*- *****
**/**/** **  **.* **.* **.* **.* **.*- **.*- **.*- **.*- *****
**/**/** **  **.* **.* **.* **.* **.*- **.*- **.*- **.*- *****
**/**/** **  **.* **.* **.* **.* **.*- **.*- **.*- **.*- ***** +

PRESS ENTER TWICE TO DELETE ALL VARIABLE CAPACITY FOR THIS WORK CENTER

                                         USE ROLL UP/DOWN
                                         F01 RESTART FACILITY
                                         F19 RETURN TO SELECT
                                         F23 DISPLAY STATUS
    
```

What to do

- To delete all variable capacity records for a production facility, press **Enter**. Press **Enter** again to flag all the records for deletion. Go to display AMVTC1.
- To see the variable capacity records for the production facility from the beginning, use **F01**.
- To review the status of and end the session, use **F23**. Go to display AMVTC6.

Function keys

USE ROLL UP/DOWN allows you to scroll forward and backward through the variable capacity records associated with this facility if the word CONTINUED appears.

F01 RESTART FACILITY shows all variable capacity records for this facility starting with the first based on the Include for Review code entered on Select display AMVTC1.

F19 RETURN TO SELECT causes the Variable Capacity Maintenance (Select) display (AMVTC1) to appear.

[Contents](#)

[Index](#)

F23 DISPLAY STATUS causes the Variable Capacity Maintenance (Status) display (AMVTC6) to appear.

Fields

For a description of the fields on this display, see “AMVTC2—Variable Capacity Maintenance (Add)”.

AMVTC6—Variable Capacity Maintenance (Status)

Use this display to review the status of the current maintenance session.

This display appears when you use **F23 DISPLAY STATUS** on the Select (AMVTC1), Add (AMVTC2), Change (AMVTC3), Delete (AMVTC4), or Delete All (AMVTC5) display.

```

DATE **/**/** A2      VARIABLE CAPACITY MAINTENANCE      STATUS      AMVTC6  **

MAINTENANCE NUMBER      ***

-----SESSION STATISTICS-----
ADDS ENTERED            *****
CHANGES ENTERED       *****
DELETES ENTERED        *****
DELETE ALL ENTERED     *****
TOTAL TRANSACTIONS     *****

F24 END OF JOB

```

What to do

- To end the session and schedule the Variable Capacity Master File Maintenance report (AMVTC) for printing, use **F24**. Go to display AMVT70.
- To return to the previous display, press **Enter**.

Function keys

F24 END OF JOB causes the Production Facility Maintenance display (AMVT70) to appear.

Fields

All the fields on this display are information only.

SESSION STATISTICS.

ADDS ENTERED: This field contains the number of variable capacity add transactions.

CHANGES ENTERED: This field contains the number of variable capacity change transactions.

DELETES ENTERED: This field contains the number of variable capacity delete transactions.

Contents	Index
--------------------------	-----------------------

DELETE ALL ENTERED: This field contains the number of Delete All transactions entered.

Option 4. Routing (AMEM05)

Use this option anytime you want to do one of the following:

- Add a new operation to the Routing file
- Change or delete a routing operation already in the Routing file
- Delete a routing
- Copy an existing routing (same-as-except)
- Review a routing
- Add, change, or delete an additional description
- Define or remove milestone groups.

Routing file maintenance allows you to maintain routing operations and routing descriptions. Routing batch update is prevented from executing if Production Facility maintenance, Item Master file maintenance, product costing, or Product Structure batch update is executing.

Use Routing file maintenance to add, change, or delete an operation of a routing or delete all the operation records in an entire routing. You can also use the same-as-except (SAE) transaction to duplicate existing routings and modify them.

Multiple users maintain different records in the same master file at the same time. This capability is called concurrent master file maintenance.

Notes:

1. You can do Routing file maintenance only if the Routing and Production Facility files were selected during application tailoring.
2. You can review, add, change, and delete additional descriptions only if additional descriptions was selected during application tailoring.

What information you need:

- Parent item number(s)
- Component item number(s)
- Operation sequence number(s)
- Milestone type (for milestone group maintenance).

What reports are printed:

- Routing Transaction List (AMEU9)
- Routing Update Audit List (AMEB42).

What forms you need:

- Routing File Maintenance (PM-17)
- Routing File Milestone Group Maintenance (PM-18)
- Routing Description File Maintenance—Additional Operation Descriptions (PM-21).

AMEU61—Routing File Maintenance Data Entry Control

Use this display to select a batch within the Routing Maintenance Transaction file to either work on or review.

This display appears when you select option 4 (Routing) on the File Maintenance menu (AMEM05).

Note: This display prevents Routing data entry from other work stations.

```

DATE **/**/**          ROUTING FILE MAINTENANCE          AMEU61  **
                        DATA ENTRY CONTROL

ENTER BATCH NUMBER  nnn          BATCHES CURRENTLY IN USE ***
                                  LOCATE BATCH nnn

BATCH  *--ORIGINAL--*  *---LAST---*  STATUS  DATE  RECORDS
NO.    WSID   OPID    WSID   OPID         **/**  USED
***    *****  ***    *****  ***    **/**  *****
***    *****  ***    *****  ***    **/**  *****
***    *****  ***    *****  ***    **/**  *****
***    *****  ***    *****  ***    **/**  *****
***    *****  ***    *****  ***    **/**  *****
***    *****  ***    *****  ***    **/**  *****
***    *****  ***    *****  ***    **/**  *****
***    *****  ***    *****  ***    **/**  *****
***    *****  ***    *****  ***    **/**  *****
***    *****  ***    *****  ***    **/**  *****
***    *****  ***    *****  ***    **/**  *****
***    *****  ***    *****  ***    **/**  *****
***    *****  ***    *****  ***    **/**  *****
***    *****  ***    *****  ***    **/**  *****
***    *****  ***    *****  ***    **/**  *****
***    *****  ***    *****  ***    **/**  *****
***    *****  ***    *****  ***    **/**  *****
***    *****  ***    *****  ***    **/**  *****
***    *****  ***    *****  ***    **/**  *****
***    *****  ***    *****  ***    **/**  *****

                                  USE ROLL UP/DOWN
                                  F04 NEW BATCH
                                  F24 CANCEL JOB
    
```

What to do

- To use an existing batch, type in the batch number and press **Enter**. Go to display AMEU18.
- To start a new batch, use **F04**. Go to display AMEU11.

Function keys

USE ROLL UP/DOWN allows you to scroll up and down through the list of batches on the displays.

F04 NEW BATCH causes a new batch be started.

F24 CANCEL JOB ends the work station session and causes the File Maintenance menu (AMEM05) to appear again.

Fields

ENTER BATCH NUMBER. Required. To edit an existing batch, type in the batch number and press **Enter**.

You can edit a batch whose status is ACTIVE only if the originating work station identifier (**ORIG WSID** field) matches the work station ID in the upper right corner of your display.

You cannot edit batches with a status of UPDATE, FINISH, or DELETE.

BATCHES CURRENTLY IN USE. The number of batches currently in the system. This count includes all batches, regardless of status.

LOCATE BATCH. To find a batch that is in the list but does not appear on the display, type in its batch number and press **Enter**. This is intended as an alternative to the **ROLL UP/DOWN** keys.

BATCH NO. The sequential number assigned by the application to the batch, at the time the batch is created.

ORIGINAL.

WSID (Original work station identification). The work station at which transactions for the batch were originally entered. For offline batches, asterisks appear.

OPID (Original operator identification). The ID of the operator who entered the batch. The operator ID appears only if security is in effect. For offline batches, asterisks appear.

LAST.

WSID (Last work station identification). The work station at which the batch was last selected. For offline batches, asterisks appear.

OPID (Last operator identification). The ID of the operator who last selected the batch. The operator ID appears only if security is in effect. For offline batches, asterisks appear.

STATUS. One of the following batch status indicators:

- ACTIVE** The batch is either being used by another work station or is incomplete because of some abnormal condition, such as loss of power. An active batch can be attached to only from the work station that started it.
- SUSPND** The operator has used **F23** on one of the Status displays, AMEU18, AMEU35, or AMEU43, to suspend the batch. Apparently there are more transactions to be entered in the batch. A suspended batch can be selected from any work station.
- CLOSED** The operator has used **F24** on one of the Status displays, AMEU18, AMEU35, or AMEU43 to close the batch. The application can use it to update the master files.
- DELETE** The operator has used **F20** on one of the Status displays, AMEU18, AMEU35, or AMEU43 to delete the batch. The batch becomes available when the application removes deleted batches from the Product Structure Data Entry file.
- UPDATE** The application has selected the batch for updating the master files. If question X02 was answered Y on the Installation Questionnaire, this batch becomes available for starting a new batch as soon as the updating is completed.

[Contents](#)

[Index](#)

FINISH The batch has been applied to the master files but that the transactions remain in the batch until the files are saved (a reply of N to question X02 on the Installation Questionnaire).

DATE. The creation date or date of last activity for the batch.

RECORDS USED. The number of transactions currently in the batch.

AMEU71—Routing File Maintenance (Select)

Use this display to enter the type of action you want to perform on the routing for the item you enter.

This display appears when you type a valid reference number on display AMEU61 or use F19 (Return To Select) on any of the following Routing File Maintenance displays: AMEU72, AMEU73, AMEU75, AMEU76, AMEU77, AMEU78, AMEU21, AMEU22, AMEU23, AMEU24, AMEU27, AMEU81, or AMEUK1.

```

DATE **/**/**          ROUTING FILE MAINTENANCE          SELECT  AMEU71  **

                                     ENTER--
                                     ITEM   aaaaaaaaaaaaA15          BATCH  ***
                                     ACTION  A

SELECT ONE OF THESE ACTIONS
A ADD
C CHANGE
D DELETE
R DELETE ROUTING
X SAME-AS-EXCEPT
V REVIEW ROUTING INCLUDING PENDING CHANGES
T ADD/CHG/DEL ADDL DESC

                                     F05 REVIEW
                                     F24 STATUS
    
```

What to do

To perform Routing file maintenance, type in the information requested and press **Enter**. Depending on which action code you selected, one of the following displays appears:

Action Code	Meaning	Display
A	Add	AMEU72
C	Change	AMEU73
D	Delete	AMEU75
R	Delete routing	AMEU76
X	Same-as-except	AMEU21
V	Review routing including pending changes	AMEUG1
T	Add, change, or delete additional descriptions	AMEU78

Function keys

F05 REVIEW causes display AMEU81 to appear.

F24 STATUS causes display AMEU77 to appear.

Fields

[?] appears next to a field name in the following field definitions to identify a field from which you can begin a master file search.

BATCH. The batch number to which you are currently attached.

ITEM (ITNBR) [?]. Required. Type in the item number of the parent item whose routing you want to maintain.

ACTION. Required. Type in one of the following action codes:

A To add an operation to a parent item's routing.

C To change an operation in a parent item's routing.

D To delete an operation from a parent item's routing and the additional description lines if present.

R To delete the entire routing (including all operations and additional detail) for a parent item.

X To copy the routing of an existing parent item to create a routing for a similar new parent item.

Note: When action X is selected, all SAE adds, changes, and deletes to the parent structure being created must be made in SAE mode.

V To review a routing as it should appear when the Routing file is updated. This includes any pending add, change, delete, routing delete, additional description add, change, delete, and multiple delete, and same-as-except (SAE) transactions entered in the batch you are working with and in any other closed or suspended batches.

T To access display AMEU78. You can then add, change, or delete the additional routing operation description for a parent item.

AMEU72—Routing File Maintenance (Add/Review)

Use this display to add an operation to a routing for an existing item, to enter descriptive data about that operation, and to review add transactions entered in the Routing Maintenance Batch file.

This display appears when you type a valid item number and action A (add) on display AMEU71.

This display lets you add detail operations to the routing for an existing item. It appears only if you select the Add action. You can enter the necessary information for an operation. You can also review the add transactions you have entered in the Routing Maintenance Batch file.

```

DATE **/**/**          ROUTING FILE MAINTENANCE          ADD AMEU72 **
ITEM *****          *****
OPER M          ---RUN--- --SETUP-- MOVE OPER
SEQ S DESCRIPTION          FAC TBC MACH LABOR TIME CREW DAYS STATUS TOOL
**** * *****          ***** * **.* **.* **.* **.* **.* **.* **.* **.*
      ADDL DESC COUNT: ***      AVG: **.* **.* **.* **.*      PROCESS *****
**** * *****          ***** * **.* **.* **.* **.* **.* **.* **.* **.*
      ADDL DESC COUNT: ***      AVG: **.* **.* **.* **.*      PROCESS ***** +

ADD OPERATION
OPERATION SEQ          aaA4          DESCRIPTION aaaaaaaaaaaaaaaaaA20          BATCH ***
FACILITY ID          aaaA5          TIME BASIS A          OUTSIDE COST nnnnnnnnnnn.nnnnnnnnn          PRINT FLAG A
RUN MACHINE          nnn.nn          SETUP LABOR TIME          nnn.nn          REPORT POINT n
RUN LABOR          nnn.nn          SETUP CREW SIZE          nn          OPER RUN QTY          nnnn.nnn
MOVE DAYS          nn.nn          OPER STATUS CODE          A2
TOOL          aaaaA6          STANDARD YIELD          n.nnn          USE ROLL UP/DOWN
PROCESS SHEET          aaaaA6          CURRENT YIELD          n.nnn          F06 ROUTING/BATCH
INV TRAN CODE          A2          SELECT CODE          A2          F10 ADDL DESCRIPTION
          F11 MILESTONE ENTRY
          F19 RETURN TO SELECT
          F24 STATUS
    
```

What to do

- To add a routing operation, type in the information requested and press **Enter**. The operation record is added to the batch and the display appears again.
- To review the changes you have made, use **F06** after you press **Enter**. To see the Routing file detail, use **F06** again.
- To end the session or review the status of Routing file, use **F24**.

Function keys

USE ROLL UP/DOWN allows you to scroll up and down through the list of operations on the displays.

F06 ROUTING/BATCH shows you the changes you have made to the Routing Maintenance Batch file on the top portion of the display. Use **F06** again to see AMEU72 with Routing Master file detail.

Note: The information you type on the lower portion of the display will not appear in REVIEW mode until you press **Enter**.

F10 ADDL DESCRIPTION causes display AMEU78 to appear.

F11 MILESTONE ENTRY causes display AMEU79 to appear.

F19 RETURN TO SELECT ignores the data you just entered and causes display AMEU71 to appear again.

F24 STATUS causes display AMEU77 to appear.

Fields

[?] appears next to a field name in the following field definitions to identify a field from which you can begin a master file search.

The fields on the top portion of the display are described first. The top portion of the display shows either detail from the Routing Master file (when the display is in ADD mode) for the parent item you entered on display AMEU71 or shows the changes you have made to the Routing Maintenance Batch file (when the display is in REVIEW mode). The fields shown in ADD mode are described first followed by the fields shown in REVIEW mode and the fields shown on the bottom portion of the display in both modes.

ITEM (ITNBR). The number of the parent item to whose routing you want to add an operation.

Description (ITDSC). This field appears to the right of the field Item and has no heading. It shows the description of the item that normally appears on invoices, inquiries, and reports.

OPER SEQ (Operation Sequence Number) (OPSEQ). The number defining the sequence in which the operation is listed or shown; for example, 0010, 0020, 0030, and so on, with 0010 as the first operation. Using multiples of 10 allows you to insert operations 0012, 0023, 0024 later.

MS (Milestone) (MLSTN). The milestone type for a suboperation belonging to a milestone group:

- B** The first suboperation of a milestone group with no activity reported
- S** A suboperation of a milestone group that is between the first and the last suboperation
- J** The last suboperation of a milestone group for a job shop type of milestone group
- F** The last suboperation of a milestone group for a flow shop type of milestone group.

DESCRIPTION (OPDSC). A short description of the task performed during this operation.

FAC (Facility ID) (WKCTR). The ID (user assigned) of the production facility where this operation is performed.

TBC (Time Basis Code) (TBCOD). This code is used to develop standard run labor time, run machine time, and run labor costs:

blank	Hours per unit
1	Hours per 10 units
2	Hours per 100 units
3	Hours per 1,000 units
4	Hours per 10,000 units
P	Pieces per hour
H	Hours per lot
M	Minutes per piece
C	Cost per piece (used for outside operations).

Note: M applies to all time fields entered; all other time basis codes apply only to run machine and run labor.

RUN MACHINE (RUNMC). The run machine time for this operation. When adjusted by the Time Basis Code, this is the time in hours or minutes that the machine in the associated facility is expected to run to produce one or more units (depending on the TBC) of the associated item. If the time basis code is C, the run machine time is not adjusted. PDM product costing also uses this field to calculate standard and current labor overhead content this-level in the associated Item Master B-record.

RUN LABOR (RUNLB). When Run Labor Time is extended by the time basis code (TBC), this field shows the expected hours or minutes of run labor necessary to produce one or more units (depending on the TBC) of this item. If the time basis code is C, which indicates an outside operation, you should not enter a value in this field. Instead, you should use the **Outside Cost** field. Any value entered into the run labor field when the time basis code is C is ignored for costing purposes. If the time basis code is P, labor represents the quantity per hour. If the cost technique code is R, PDM product costing uses this field to determine the run labor portion of standard and current labor and overhead content this-level in the associated Item Master B-record.

SETUP TIME (SULHR). The setup labor time for this operation. PDM product costing uses this field to calculate standard and current labor and manufacturing overhead content this-level in the associated Item Master B-record.

SETUP CREW (SUCSZ). The number of people in the crew that does the setup of this operation. If the time basis code is C, this field should show 1. PDM product costing also uses this field to calculate standard and current overhead content this-level in the associated Item Master B-record. The default is 1. The setup machine hours are calculated as setup labor hours divided by setup crew size.

MOVE DAYS (MOVTM). The planned time, in days, required to move an order to this operation from its last location. If the time basis code is C, this field shows the total lead time from completion of the previous operation to receipt back from the vendor. This value is used in PC&C's manufacturing order scheduling routines.

OPER STATUS (Operation Status Code) (OPSTC). Indicates one of the following Operation Status Codes for this operation:

00	Inactive
10	Active.

TOOL (Tool Number) (RTOOL). The tool number for the tool or tools needed to perform this operation.

ADDL DESC COUNT (Additional Description Count) (NODES). The number of additional routing description records for the operation. This field appears only if the additional routing operation description function was selected during application tailoring.

The three averages, Run Mach, Run Labor, and Setup Time, appear on the top half of the display. These fields are updated by PC&C during order closeout.

RUN MACH (Average Run Machine Time) (AVGRM). The average of actual run machine time for each open operation for a particular routing record, adjusted by the Time Basis Code.

RUN LABOR (Average Run Labor Time) (AVGRL). The average of actual run labor time worked on each open operation for a particular routing record, adjusted by the Time Basis Code.

SETUP TIME (Average Setup Labor Time) (AVGSL). The average of actual setup labor time worked on each open operation for a particular routing record.

PROCESS (Process Sheet) (PRONO). The process sheet number that is used to identify a user document that explains detailed instructions about processes required within this operation.

The following fields appear on the top portion of the display in REVIEW mode.

TRAN NO (Transaction Number). The application generated numbers used to select individual transactions for deletion or additional detail.

TRANSACTION TYPE. The type of transaction: add routing, change routing, delete routing, routing delete, add description, change description, delete description, delete routing description, SAE header, SAE change, SAE delete, SAE add, and SAE additional description maintenance.

ITEM (ITNBR). The number of the parent item whose routing is affected by this transaction.

OPER SEQ (Operation Sequence Number) (OPSEQ). The sequence number of the operation affected by this transaction.

FAC (Facility ID) (WKCTR). The unique code that identifies the area where this operation takes place. If the time basis code is C, the ID represents a vendor (or group of vendors).

LINE (Description Line Number) (DSQNO). The line number of the routing operation's additional description.

OLD ITEM. The old parent item number involved in the SAE Header transaction.

The bottom half of the display shows fields you use to enter information about the routing operation. These fields appear in both ADD and REVIEW mode. Two fields, OPERATION SEQ and FACILITY ID, are required. The BATCH field is informational only.

OPERATION SEQ (Operation Sequence Number) (OPSEQ). Type in the number defining the sequence in which the operation should be listed or shown; for example,

0010, 0020, 0030, and so on, with 0010 as the first operation. Using multiples of 10 allows you to insert operations 0012, 0023, 0024 later. All four positions of this field must be entered; leading zeroes must be typed in.

DESCRIPTION (OPDSC). Type in a short description of the task performed during this operation.

BATCH. This field shows the batch number to which you are currently attached.

FACILITY ID (WKCTR) [?]. Type in the ID (user assigned) of the facility where this new operation is performed. If the time basis code is C, this ID represents a vendor (or group of vendors). The facility cannot be a production line.

TIME BASIS CODE (TBCOD). This code is used to develop standard run labor time, run machine time, and run labor costs. Type in one of the following codes:

blank	Hours per unit
1	Hours per 10 units
2	Hours per 100 units
3	Hours per 1,000 units
4	Hours per 10,000 units
P	Pieces per hour
H	Hours per lot
M	Minutes per piece
C	Cost per piece (used for outside operations).

RUN MACHINE (RUNMC). Type in the run machine time for this operation. When adjusted by the time basis code (TBC), this is the time in hours or minutes that the machine in the associated facility is expected to run to produce one or more units (depending on the TBC) of the associated item. If the time basis code is C, the run machine time is not adjusted. PDM product costing also uses this field to calculate standard and current labor overhead content this-level in the associated Item Master B-record.

SETUP LABOR TIME (SULHR). Type in the setup labor time for this operation. PDM product costing uses this field to calculate standard and current labor and labor overhead content this-level in the associated Item Master B-record.

REPORT POINT (IRCOD). This field appears if Repetitive Production Management (REP) is interfacing and this is not a purchased item. Type a code that shows whether reporting is required for this operation when the item appears on a REP schedule. Valid codes are:

1	Reporting is required
0	Reporting is not required; backflushing occurs.

If this is a purchased item, this field does not appear.

RUN LABOR (RUNLB). Type in the run labor time for this operation. When adjusted by the time basis code in this record, this becomes the expected hours or minutes of run labor necessary to produce one unit of this item. If the time basis code is C, which indicates an outside operation, you should not enter a value in this field. Instead, you should use the **Outside Cost** field. Any value entered into the run labor field when the time basis code is C is ignored for costing purposes. If the time basis code is P, labor represents the quantity per hour. If the cost technique code is R, PDM product costing uses this field to determine the run labor portion of standard and current labor and labor overhead content this-level in the associated Item Master B-record.

SETUP CREW SIZE (SUCSZ). Type in the number of people in the crew that does the setup of this operation. If the time basis code for this operation is C, type in 1. PDM product costing also uses this field to calculate standard and current overhead content this-level in the associated Item Master B-record. The default is 1. The setup machine hours are calculated as setup labor hours divided by setup crew size.

OPER RUN QTY (PUNIT). The standard quantity of the end item you are processing at this facility.

MOVE DAYS (MOVTM). Type in the planned time in days required to move an order to this operation from its last location. This value is used in manufacturing order scheduling routines. If the time basis code for this operation is C, type in the total lead time from completion of the previous operation to receipt from the vendor.

Note: This is a signed field. After typing in the field value, remember to press either **FIELD EXIT** or **FIELD +** if you entered a positive value or **FIELD -** if you entered a negative value.

OPER STATUS CODE (OPSTC). Type in one of the following operation status codes for this operation:

00 Inactive
10 Active.

TOOL (Tool Number) (RTOOL). Type in the number that is used to identify a tool or tools needed to perform this operation.

STANDARD YIELD (Standard Operation Yield) (SYTOP). Type in the percentage that represents the budgeted or annual estimate of the amount of this parent item expected to remain in the production process at the end of an operation compared to the amount available at the start of the operation. This percentage is used for standard costing. The default is 1.000 (100%).

PROCESS SHEET (PRONO). Type in the process sheet number that is used to identify a user document that explains detailed instructions about processes required within this operation.

CURRENT YIELD (Current Operation Yield) (CYTOP). Type in the percentage that represents today's or the near-term future expected amount of this parent item that remains in the production process at the end of an operation compared to the amount available at the start of the operation. This percentage is used for current costing, scheduling, and materials requirements. The default is 1.000 (100%).

INV TRAN CODE (TCODE). Type one of the following codes to indicate what type of transaction is to be processed during P.O. receipt entry, in purchasing, when receiving routings are used.

VA Vendor acknowledgment
RD Receipt to dock
RI Receipt to inspection
RP Stock receipt
PQ Purchase quantity control.

SELECT CODE (SELNO). Type a number from 01 to 99 to identify the unique alternate routing identification for this operation.

AMEU73—Routing File Maintenance (Change/Review)

Use this display to change information in each operation in a parent item's routing.

This display appears when you enter a valid item number and action C (change) on display AMEU71.

```

DATE **/**/**          ROUTING FILE MAINTENANCE          CHANGE AMEU73  **
ITEM *****          *****
OPER M                ---RUN---  --SETUP--  MOVE OPER
SEQ S DESCRIPTION    FAC TBC MACH LABOR TIME CREW  DAYS STATUS TOOL
**** * *****          ***** *  **.* **.* **.* ** *  **.* **.* **.* **
**** * *****          ***** *  **.* **.* **.* ** *  **.* **.* **.* **
      ADDL DESC COUNT: ***      AVG: **.* **.* **.* **      PROCESS *****
      ADDL DESC COUNT: ***      AVG: **.* **.* **.* **      PROCESS ***** +

CHANGE OPERATION
OPERATION SEQ      aaA4      DESCRIPTION aaaaaaaaaaaaaaaaaA20  PRINT FLAG  A
FACILITY ID        aaaA5      TIME BASIS  A      OUTSIDE COST nnnnnnnnnn.nnnnnnnn
RUN MACHINE        nnn.nn      SETUP LABOR TIME nnn.nn  REPORT POINT  n
RUN LABOR          nnn.nn      SETUP CREW SIZE  nn      OPER RUN QTY  nnnn.nnn
MOVE DAYS          nn.nn      OPER STATUS CODE  A2      USE ROLL UP/DOWN
TOOL               aaaaA6      STANDARD YIELD   n.nnn  F06 ROUTING/BATCH
PROCESS SHEET      aaaaA6      CURRENT YIELD   n.nnn  F10 ADDL DESCRIPTION
INV TRAN CODE      A2      SELECT CODE     A2      F11 MILESTONE ENTRY
                                   F18 REFRESH BOTTOM
                                   F19 RETURN TO SELECT
                                   F24 STATUS
    
```

What to do

- To change a routing operation, type in the routing sequence number and press **Enter**. Then type in the information requested and press **Enter** again. The updated routing record is added to the batch and the display appears again.
- To review the changes you have made, use **F06** after you press **Enter**. To see the Routing file detail, use **F06** again.
- To end the session or review the status of Routing file, use **F24**.

Function keys

USE ROLL UP/DOWN allows you to scroll up and down through the list of operations on the displays.

F06 ROUTING/BATCH shows you the changes you have made to the Routing Maintenance Batch file on the top portion of the display. Use **F06** again to see AMEU73 with Routing Master file detail.

Note: The information you type on the lower portion of the display will not appear in REVIEW mode until you press **Enter**.

F10 ADDL DESCRIPTION causes display AMEU78 to appear.

F11 MILESTONE ENTRY causes display AMEU79 to appear.

F18 REFRESH BOTTOM erases any data you typed in and shows AMEU73 as it first appeared.

[Contents](#)

[Index](#)

F19 RETURN TO SELECT ignores the data you just entered and causes display AMEU71 to appear again.

F24 STATUS causes display AMEU77 to appear.

Fields

See “AMEU72—Routing File Maintenance (Add/Review)” for descriptions of the fields that appear on this display.

AMEU75—Routing File Maintenance (Delete)

Use this display to delete an operation (including any additional detail) from a parent item's routing.

This display appears when you type a valid item number and action D (delete) on display AMEU71.

An error message appears for items if the operation being deleted matches another operation in the Product Structure file. The deletion is not allowed. Remove the reference in the Product Structure file and try again.

```

DATE **/**/**          ROUTING FILE MAINTENANCE          DELETE AMEU75  **
ITEM *****
OPER M          -----RUN----- --SETUP-- MOVE OPER
SEQ S DESCRIPTION          FAC TBC MACH LABOR TIME CREW DAYS STATUS TOOL
***** * ***** * **** * **** * **** * **** * **** * **** * **** *
ADDL DESC COUNT: ***      AVG: **** * **** * **** * **** *      PROCESS *****
***** * ***** * **** * **** * **** * **** * **** * **** * **** *
ADDL DESC COUNT: ***      AVG: **** * **** * **** * **** *      PROCESS ***** +

DELETE ROUTING OPERATION

                                         BATCH ***

OPERATION SEQ aaA4 *****

PRESS ENTER TO DELETE OPERATION AND ADDL DESCRIPTIONS

                                         USE ROLL UP/DOWN
                                         F19 RETURN TO SELECT
                                         F24 STATUS
    
```

What to do

- To delete a routing operation, type in the operation sequence number and press **Enter**. To confirm the transaction, press **Enter** again. The updated routing record is added to the batch and the display appears again.
- To end the session or review the status of Routing file, use **F24**.

Function keys

USE ROLL UP/DOWN allows you to scroll up and down through the list of operations on the displays.

F19 RETURN TO SELECT ignores the data you just entered and causes display AMEU71 to appear again.

F24 STATUS causes display AMEU77 to appear.

Fields

See “AMEU72—Routing File Maintenance (Add/Review)” for descriptions of the fields on the top half of this display. These fields are informational only.

[Contents](#)

[Index](#)

BATCH. The batch number to which you are currently attached.

OPERATION SEQ (Operation Sequence Number) (OPSEQ). Required. Type in the sequence number of the operation that you want to delete within the parent item's routing.

AMEU76—Routing File Maintenance (Routing Delete)

Use this display to delete an entire routing (including any additional operation detail) of a parent item.

This display appears when you enter a valid item number and action R (delete routing) on display AMEU71.

```

DATE **/**/**          ROUTING FILE MAINTENANCE          ROUTING DELETE  AMEU76  **
ITEM *****
OPER M          ---RUN---  --SETUP--  MOVE OPER
SEQ S DESCRIPTION          FAC  TBC MACH  LABOR  TIME CREW  DAYS STATUS TOOL
**** * *****
**** * ADDL DESC COUNT: ***  AVG: ***.***  ***.***  ***.***  PROCESS *****
**** * *****
**** * ADDL DESC COUNT: ***  AVG: ***.***  ***.***  ***.***  PROCESS ***** +

ROUTING DELETE

                                     BATCH ***

PRESS ENTER TO DELETE THE ABOVE ROUTING
INCLUDING ALL OPERATIONS AND ADDL DESCRIPTIONS

                                     USE ROLL UP/DOWN
                                     F19 RETURN TO SELECT
                                     F24 STATUS
    
```

What to do

- To delete an entire routing, press **Enter**.

Notes:

1. Check the item number to make sure that this is the routing you want to delete. Operations have to be added back to a routing one at a time.
2. You cannot delete an operation from the Routing file if there is a record in the Product Structure file whose Operation Where First Used (OPWFU) field refers to the operation you are deleting.

- To end the session or review the status of Routing file, use **F24**.

Function keys

USE ROLL UP/DOWN allows you to scroll up and down through the list of operations on the displays.

F19 RETURN TO SELECT does not delete the routing and causes display AMEU71 to appear again.

F24 STATUS causes display AMEU77 to appear.

[Contents](#)

[Index](#)

Fields

See “AMEU72—Routing File Maintenance (Add/Review)” for descriptions of the fields on the top half of this display. These fields are informational only.

AMEU77—Routing File Maintenance (Batch Status)

Use this display to end the current Routing file maintenance session and to review the status of routing transactions and description transactions, and the batch to which you are currently attached.

This display appears when you select a closed, suspended, or an active batch on display AMEU61, or if you select **F24 STATUS** on any of the following Routing File Maintenance displays: AMEU71, AMEU72, AMEU73, AMEU75, AMEU76, AMEU78, or AMEU81.

```

DATE **/**/**          ROUTING FILE MAINTENANCE          BATCH STATUS AMEU77  **
----- BATCH STATISTICS -----          BATCH ***

- ROUTING TRANSACTIONS -
ADDS ENTERED          *****
CHANGES ENTERED     *****
DELETES ENTERED      *****
SAME-AS-EXCEPT HEADER  ***
ROUTING DELETES ENTERED  ***
MILESTONE TRANSACTIONS *****

- DESCRIPTION TRANSACTIONS -
ADDS ENTERED          *****
CHANGES ENTERED     *****
DELETES ENTERED      *****
MULTI DELETES ENTERED *****

- BATCH TOTALS -
TOTAL TRANSACTIONS    *****

                                F04 UPDATE NOW
                                F20 DELETE BATCH
                                F23 SUSPEND BATCH
                                F24 CLOSE BATCH

```

What to do

- To close and update the batch immediately, use **F04**. Your work station is not available until the update is complete. The application schedules the reports for printing.
- To delete the batch, use **F20**. You must use **F20** twice to confirm the delete. The application schedules the reports for printing.
- To suspend the batch, use **F23**.
- To close the batch and schedule a job to update the batch, use **F24**. The application schedules the reports for printing.

The File Maintenance menu (AMEM05) appears.

Function keys

You should suspend the batch using **F23** and update the Routing file at a later time to avoid conflicts with any other jobs.

F04 UPDATE NOW closes the batch and processes it immediately for update to the Routing file. Your work station is attached to Routing File Load and Maintenance program (AMEB4) until completion of all updates. Upon completion, the File Maintenance menu (AMEM05) appears again.

F20 DELETE BATCH schedules a job to delete the batch and causes the File Maintenance menu (AMEM05) to appear again.

Use **F20** again to confirm the batch deletion.

F23 SUSPEND BATCH suspends your batch and causes the File Maintenance menu (AMEM05) to appear again.

F24 CLOSE BATCH schedules a job to process the closed batch and causes the File Maintenance menu (AMEM05) to appear again.

Fields

All of the fields on this display are informational only.

BATCH. The number of the batch to which you are currently attached.

BATCH STATISTICS—ROUTING TRANSACTIONS.

ADDS ENTERED. The number of transactions in the batch that add operations to a parent item's routing.

CHANGES ENTERED. The number of transactions in the batch that change operations of a parent item's routing.

DELETES ENTERED. The number of transactions in the batch that delete operations from a parent item's routing.

SAME-AS-EXCEPT HEADER. The number of transactions in the batch that copy an existing parent item's routing to create a routing for a similar parent item.

ROUTING DELETES ENTERED. The number of transactions in the batch that delete the complete routing for a parent item.

MILESTONE TRANSACTIONS. The number of Milestone Group Define/Remove transactions in the batch.

BATCH STATISTICS—DESCRIPTION TRANSACTIONS.

ADDS ENTERED. The number of transactions in the batch that add descriptions to a routing operation.

CHANGES ENTERED. The number of transactions in the batch that change descriptions in a routing operation.

DELETES ENTERED. The number of transactions in the batch that delete descriptions in a routing operation.

MULTI DELETES ENTERED (Multiple Deletes Entered). The number of transactions in the batch that delete all descriptions in a routing operation.

Contents	Index
--------------------------	-----------------------

BATCH STATISTICS—BATCH TOTALS.

TOTAL TRANSACTIONS. The number of transactions in the batch.

AMEU78—Routing File Maintenance (Update)

Use this display to add, change, or delete individual or multiple descriptions for a routing operation.

This display appears when you enter a valid item number and action code T (add/chg/del addl desc) on display AMEU71, or when you select **F10 ADDL DESCRIPTION** on either display AMEU72 or AMEU73.

Each line of the additional description for the routing operation in the Routing Additional Description file appears on the display. Use the blank lines to add description information. To delete a line, replace the line number with zeros. To change a sequence number for an existing line, type the new sequence number over the original number. To change an existing description, type over the original text with the new description. The display shows up to 999 lines of additional description.

Note: When you press **Enter**, the updated description is written to the Routing Maintenance Batch file (RTMANT) as add, change, and/or delete transactions and is cleared from the display. Be sure that the information you have typed in is correct before you press **Enter**. To review the transactions, use **F19**.

```
DATE **/**/**      ROUTING FILE MAINTENANCE      UPDATE      AMEU78 **  
  
ITEM      *****      OPER SEQ      ****      FACILITY ID      *****  
OPERATION DESCRIPTION      *****  
LINE      ADDITIONAL DESCRIPTION  
nnn      aaaaaaaaaaaaaaaaaaaaaaaaaaaaaaaaaaaaaA40  
nnn      aaaaaaaaaaaaaaaaaaaaaaaaaaaaaaaaaaaaaA40  
nnn      aaaaaaaaaaaaaaaaaaaaaaaaaaaaaaaaaaaaaA40  
nnn      aaaaaaaaaaaaaaaaaaaaaaaaaaaaaaaaaaaaaA40  
nnn      aaaaaaaaaaaaaaaaaaaaaaaaaaaaaaaaaaaaaA40  
nnn      aaaaaaaaaaaaaaaaaaaaaaaaaaaaaaaaaaaaaA40  
nnn      aaaaaaaaaaaaaaaaaaaaaaaaaaaaaaaaaaaaaA40  
nnn      aaaaaaaaaaaaaaaaaaaaaaaaaaaaaaaaaaaaaA40  
nnn      aaaaaaaaaaaaaaaaaaaaaaaaaaaaaaaaaaaaaA40  
nnn      aaaaaaaaaaaaaaaaaaaaaaaaaaaaaaaaaaaaaA40  
nnn      aaaaaaaaaaaaaaaaaaaaaaaaaaaaaaaaaaaaaA40  
  
ADDITIONAL DESCRIPTIONS  
OPER SEQ  
aaA4  
DELETE ALL DESCRIPTIONS FOR THIS OPERATION <Y/N> A  
  
USE ROLL UP/DOWN  
F03 PREV SCREEN  
F19 RETURN TO SELECT  
F24 STATUS
```

What to do

- To select additional descriptions for an operation sequence, type the sequence number in the **ADDITIONAL DESCRIPTIONS OPER SEQ** field and press **Enter**.
 - To add a line to the description shown on the display, type a line number in the **LINE** field and the description in the **ADDITIONAL DESCRIPTION** field and press **Enter**.
 - To change the description shown on the display, type over the text you want to change and press **Enter**.
 - To delete a line in the description shown on the display, type all zeros for the line number and press **Enter**.

- To delete all description records for this routing operation, type **Y** in the **DELETE ALL DESCRIPTIONS FOR THE OPERATION** field and press **Enter**.
- To end the session or to review the status of the Routing file use **F24**. Go to display AMEU77.
- To delete all descriptions for an operation sequence type the sequence number in the **ADDITIONAL DESCRIPTIONS OPER SEQ** field and **Y** in the **DELETE ALL DESCRIPTIONS FOR THIS OPERATION** field and press **Enter**.
- To end the session or to review the status of the Routing file use **F24**. Go to display AMEU77.

Function keys

USE ROLL UP/DOWN allows you to scroll up and down through the list of operations on the displays.

F03 PREV SCREEN causes one of the following displays to appear again: AMEU71, AMEU72, or AMEU73.

F19 RETURN TO SELECT ignores the data you just entered and causes display AMEU71 to appear again.

F24 STATUS causes display AMEU77 to appear.

Fields

ITEM (Item Number) (ITNBR). The number of the parent item for the routing operation.

OPER SEQ (Operation Sequence Number) (OPSEQ). The number of the routing operation you want to update.

FACILITY ID (WKCTR). The facility where this operation is performed.

OPERATION DESCRIPTION (OPDSC). A short description of this operation.

LINE (Description Line Number) (DSQNO). The line number of the routing operation's additional description. This field is required. Type in a new line number to add a line. You can change existing line numbers to allow the addition of new lines. Type zeros over an existing line number to delete a line.

ADDITIONAL DESCRIPTION (ADDSC). The additional descriptive information for a routing operation. Type in the new or changed description. When you type zeros in the **LINE** field, the additional description for that line is deleted when you press **Enter**.

ADDITIONAL DESCRIPTIONS. Use the following fields to indicate other routing operations you want to update.

OPER SEQ. (Operation Sequence Number). Type in the number of another routing operation which you want to update.

DELETE ALL DESCRIPTIONS FOR THIS OPERATION <Y/N>. Type in **Y** (Yes) to delete all additional descriptions for this operation. The default is **N** (No.)

AMEU79—Routing File Maintenance (MS-MAINT)

Use this display to enter a transaction to define or remove a milestone group for a routing. You can enter an action code for defining or removing a milestone group. To define a milestone group, you must enter the beginning and ending operation of the milestone group, and the milestone type. To remove a milestone group, you must enter only the beginning operation.

This display appears when you select **F11** on display AMEU72 or AMEU73.

```

DATE **/**/**          ROUTING FILE MAINTENANCE          MS-MAINT  AMEU79  **
ITEM *****
OPER M          -----RUN-----  --SETUP--  MOVE OPER
SEQ S DESCRIPTION          FAC  TBC MACH  LABOR  TIME CREW  DAYS STATUS TOOL
**** * *****
**** * ADDL DESC COUNT: ***  AVG:  ***.***  ***.***  ***.***  **  PROCESS *****
**** * *****
**** * ADDL DESC COUNT: ***  AVG:  ***.***  ***.***  ***.***  **  PROCESS ***** +

MILESTONE
ACTION CODE DEFINE <1>          BATCH ***
      -or- REMOVE <2>  A

BEGINNING OPERATION          aaA4
ENDING OPERATION            aaA4

MILESTONE TYPE <F,J>  A

USE ROLL UP/DOWN
F03 PREV SCREEN
F10 ADDL DESCRIPTION
F19 RETURN TO SELECT
F24 STATUS
    
```

What to do

- To define a milestone group, type in **1** in the **Action Code** field, then enter the information requested, and press **Enter**.
- To remove a milestone group, type **2** in the **Action Code** field, enter the beginning operation number, and press **Enter**.
- To end the session or to review the status of the Routing file use **F24**. Go to display AMEU77.

Function keys

USE ROLL UP/DOWN allows you to scroll up and down through the list of operations on the displays.

F03 PREV SCREEN causes one of the following displays to appear again: AMEU71, AMEU72, or AMEU73.

F10 ADDL DESCRIPTION causes display AMEU78 to appear.

F19 RETURN TO SELECT ignores the data you just entered and causes display AMEU71 to appear again.

F24 STATUS causes display AMEU77 to appear.

Fields

See “AMEU72—Routing File Maintenance (Add/Review)” for descriptions of the fields on the top half of this display. These fields are informational only. All the fields on the bottom half of the display are required.

ACTION CODE DEFINE <1> -or- REMOVE <2> (ACTCD). Type in the code to indicate if you want to define or remove a milestone group:

- 1 Define a new milestone group.
- 2 Remove a milestone group.

BEGINNING OPERATION (BEGOP). Type in the operation sequence number that identifies the detailed operation for that item that is the first operation of the milestone group.

ENDING OPERATION (ENDOP). Type in the operation sequence number that identifies the detailed operation for that item that is the last operation of the milestone group.

MILESTONE TYPE <F,J> (MSTYP). Type in the code to indicate if the milestone group is for a job shop environment or for a flow shop environment:

- J Job shop
- F Flow shop.

AMEU21—Routing File Maintenance (SAE Header)

Use this display to copy the routing of an existing parent item to create a routing for a similar new parent item.

This display appears when you type a valid parent item number and Action X (Same-As-Except) on display AMEU71.

This display lets you enter the new parent item number you want to use in the same-as-except (SAE) transaction. Once you enter a new parent item number, you cannot return to this display without starting a new cycle (by entering another new parent item number).

```

DATE **/**/**          ROUTING FILE MAINTENANCE          SAE HEADER          AMEU21  **
PARENT ITEM *****
OPER M          ----RUN----  --SETUP--  MOVE OPER
SEQ S DESCRIPTION          FAC TBC MACH LABOR TIME CREW DAYS STATUS TOOL
**** * *****
**** * ADDL DESC COUNT: ***  AVG: ***.***.***.***.***.***  PROCESS *****
**** * *****
**** * ADDL DESC COUNT: ***  AVG: ***.***.***.***.***.***  PROCESS ***** +

SAE HEADER

BATCH ***

ENTER-- NEW PARENT ITEM  aaaaaaaaaaaaA15

PRESS ENTER TO DUPLICATE THE ORIGINAL PARENT'S ROUTINGS

USE ROLL UP/DOWN
F19 RETURN TO SELECT
F24 STATUS

```

What to do

- To copy the routing, type in the new parent item number and press **Enter**. Go to display AMEU22. To confirm the transaction, press **Enter** again.
- To end the session or to review the status of the Routing file use **F24**. Go to display AMEU26.

Function keys

USE ROLL UP/DOWN allows you to scroll up and down through the list of operations on the displays.

F19 RETURN TO SELECT ignores the data you just entered and causes display AMEU71 to appear again.

Note: When you are copying an existing routing, you should use **F19** only if you have completed all same-as-except transactions for the new item.

F24 STATUS causes display AMEU26 to appear.

Fields

[?] appears next to a field name in the following field definitions to identify a field from which you can begin a master file search.

PARENT ITEM (ITNBR). Required. The number of the parent item you entered on display AMEU71.

Description (ITDSC). This field appears to the right of the field **Parent Item** and has no heading. It shows the description of the parent item that normally appears on invoices, inquiries, and reports.

OPER SEQ (Operation Sequence Number) (OPSEQ). The number defining the sequence in which the operation is listed or shown; for example, 0010, 0020, 0030, and so on, with 0010 as the first operation. Using multiples of 10 allows you to insert operations such as 0012, 0023, and 0024 later.

MS (Milestone) (MLSTN). The milestone type for a suboperation belonging to a milestone group:

- B** The first suboperation of a milestone group with no activity reported
- S** A suboperation of a milestone group that is between the first and the last suboperation
- J** The last suboperation of a milestone group for a job shop type of milestone group
- F** The last suboperation of a milestone group for a flow shop type of milestone group.

DESCRIPTION (OPDSC). A short description of the task performed during this operation.

FACILITY ID (WKCTR). The ID (user assigned) of the production facility where this operation is performed.

TBC (Time Basis Code) (TBCOD). This code is used to develop standard run labor time, run machine time, and run labor costs:

- blank** Hours per unit
- 1** Hours per 10 units
- 2** Hours per 100 units
- 3** Hours per 1,000 units
- 4** Hours per 10,000 units
- P** Pieces per hour
- H** Hours per lot
- M** Minutes per piece
- C** Cost per piece (used for outside operations).

Note: M applies to all time fields entered; all other time basis codes apply only to run machine and run labor.

RUN MACH (RUNMC). The run machine time for this operation. When adjusted by the Time Basis Code, this is the time in hours or minutes that the machine in the associated facility is expected to run to produce one or more units (depending on the TBC) of the associated item. If the time basis code is C, the run machine time is not adjusted. PDM product costing also uses this field to calculate standard and current labor overhead content this-level in the associated Item Master B-record.

RUN LABOR (RUNLB). When Run Labor Time is extended by the time basis code (TBC), this field shows the expected hours or minutes of run labor necessary to produce one or more units (depending on the TBC) of this item. If the time basis code is C, which indicates an outside operation, no value appears in this field. If the time basis code is P, labor represents the quantity per hour. If the cost technique code is R, PDM product costing uses this field to determine the run labor portion of standard and current labor and overhead content this-level in the associated Item Master B-record.

SETUP TIME (SULHR). The setup labor time for this operation. PDM product costing uses this field to calculate standard and current labor and labor overhead content this-level in the associated Item Master B-record.

SETUP CREW (SUCSZ). The number of people in the crew that does the setup of this operation. If the time basis code is C, this field should show 1. PDM product costing also uses this field to calculate standard and current overhead content this-level in the associated Item Master B-record. The default is 1. The setup machine hours are calculated as setup labor hours divided by setup crew size.

MOVE DAYS (MOVTM). The planned time, in days, required to move an order to this operation from its last location. If the time basis code is C, this field shows the total lead time from completion of the previous operation to receipt back from the vendor. This value is used in PC&C's manufacturing order scheduling routines.

OPER STATUS (Operation Status Code) (OPSTC). Indicates one of the following Operation Status Codes for this operation:

00	Inactive
10	Active.

TOOL (Tool Number) (RTOOL). The tool number for the tool or tools needed to perform this operation.

ADDL DESC COUNT (Additional Description Count) (NODES). The number of additional routing description records for the operation. This field appears only if the additional routing operation description function was selected during application tailoring.

The three averages, Run Mach, Run Labor, and Setup Time, appear on the top half of the display. These fields are updated by PC&C during order closeout.

RUN MACH (Average Run Machine Time) (AVGRM). The average of actual run machine time for each open operation for a particular routing record, adjusted by the Time Basis Code.

RUN LABOR (Average Run Labor Time) (AVGRL). The average of actual run labor time worked on each open operation for a particular routing record, adjusted by the Time Basis Code.

SETUP TIME (Average Setup Labor Time) (AVGSL). The average of actual setup labor time worked on each open operation for a particular routing record.

PROCESS (Process Sheet) (PRONO). The process sheet number that is used to identify a user document that explains detailed instructions about processes required within this operation.

BATCH. The batch number to which you are currently attached.

[Contents](#)

[Index](#)

NEW PARENT ITEM [?]. Required. Type in the item number of the new parent.

Note: After you enter a new parent item number, you cannot return to this display without starting a new cycle (by entering another new parent item number).

AMEU22—Routing File Maintenance (SAE Change)

Use this display to enter change transactions for any of the operations of the routing you copied using display AMEU21.

This display appears following entry of a new parent item number on display AMEU21, or if you select **F06 (SAE Change)** on any of the following displays: AMEU23, AMEU24, AMEU27, or AMEU28.

```

DATE **/**/**          ROUTING FILE MAINTENANCE          SAE CHANGE    AMEU22  **
PARENT ITEM *****
OPER M                ---RUN---  --SETUP--  MOVE OPER
SEQ S DESCRIPTION    FAC  TBC MACH  LABOR  TIME CREW  DAYS STATUS TOOL
**** * *****
ADDL DESC COUNT: ***  AVG:  ***.*  ***.*  ***.*  ***.*  **  *****
**** * *****
ADDL DESC COUNT: ***  AVG:  ***.*  ***.*  ***.*  ***.*  **  *****
PROCESS ***** +

SAE CHANGE OPERATION                                BATCH ***
OPERATION SEQ   aaA4      DESCRIPTION aaaaaaaaaaaaaaaaaA20  PRINT FLAG  A
FACILITY ID     aaaA5      TIME BASIS  A      OUTSIDE COST nnnnnnnnnnn.nnnnnnnn
RUN MACHINE     nnn.nn     SETUP LABOR TIME nnn.nn  REPORT POINT  n
RUN LABOR       nnn.nn     SETUP CREW SIZE  nn        F06 SAE CHANGE
MOVE DAYS       nn.nn     OPER STATUS CODE A2        F07 SAE DELETE
TOOL            aaaaA6     STANDARD YIELD   n.nnn     F08 SAE ADD
PROCESS SHEET   aaaaA6     CURRENT YIELD    n.nnn     F10 ADDL DESCRIPTION
INV TRAN CODE   A2        SELECT CODE      A2        F11 MILESTONE ENTRY
OPER RUN QTY    nnnn.nnn  USE ROLL UP/DOWN F18 REFRESH BOTTOM
                                           F19 RETURN TO SELECT
                                           F24 STATUS
    
```

What to do

- To change any of the operations, type in the operation sequence number and press **Enter**. Type in the necessary changes and press **Enter** again.
- To cancel what you have changed on this display, use **F19**. (Make sure that you have completed all same-as-except transactions for the new parent item.) Go to display AMEU71.
- To delete an operation from the routing you copied, use **F07**. Go to display AMEU23.
- To add an operation to the routing you copied, use **F08**. Go to display AMEU24.
- To add, change, or delete an additional description for the routing you copied, use **F10**. Go to display AMEU27.
- To define or remove a milestone group for the routing you copied, use **F11** Go to display AMEU28.
- To end the session or review the status of Routing file, use **F24**. Go to display AMEU26.

Function keys

USE ROLL UP/DOWN allows you to scroll up and down through the list of operations on the displays.

F06 SAE CHANGE causes display AMEU22 to appear again with all fields on the bottom half of the display set to blanks.

F07 SAE DELETE causes display AMEU23 to appear.

F08 SAE ADD causes display AMEU24 to appear.

F10 ADDL DESCRIPTION causes display AMEU27 to appear.

F11 MILESTONE ENTRY causes display AMEU28 to appear.

F18 REFRESH BOTTOM erases any data you typed in and shows AMEU22 as it first appeared.

F19 RETURN TO SELECT ignores the information you just entered and causes display AMEU71 to appear again.

F24 STATUS causes display AMEU26 to appear.

Notes:

1. If you decide not to change any data for the operation you entered and want to change another operation using this display, use F06. This returns the fields on the bottom half of the display to blanks (including Operation Seq). You can then type in the operation sequence number of the next operation you want to change.
2. If you type in changes to fields and then decide not to enter them, use F18. This returns the fields on the bottom half of the display back to their original values. You can now type in the new changes for the operation.
3. All transactions for this parent item should be complete before using F19. A duplicate routing is created if you leave SAE mode and return using the same parent item number again.

Fields

[?] appears next to a field name in the following field definitions to identify a field from which you can begin a master file search.

PARENT ITEM (ITNBR). The number of the new parent item you entered on display AMEU21.

For a description of the remaining fields on the top half of this display, see “AMEU21—Routing File Maintenance (SAE Header)”. The bottom half of the display shows one informational field, **BATCH**, and fields you use to enter data about the operation you want to change in the new parent item’s routing.

BATCH. The number of the batch to which you are currently attached.

For a description of the remaining fields on this display, see “AMEU72—Routing File Maintenance (Add/Review)”.

AMEU23—Routing File Maintenance (SAE Delete)

Use this display to enter delete transactions for any of the operations in the routing you copied using display AMEU21.

This display appears when you select **F07 SAE DELETE** on any of the following displays: AMEU24, AMEU22, AMEU27, or AMEU28.

```

DATE **/**/**          ROUTING FILE MAINTENANCE          SAE DELETE    AMEU23  **
PARENT ITEM *****
OPER M                ---RUN---  --SETUP--  MOVE OPER
SEQ S DESCRIPTION    FAC  TBC MACH  LABOR  TIME CREW  DAYS STATUS TOOL
**** * *****
      ADDL DESC COUNT: ***  AVG:  ***.** ***.** ***.**  PROCESS *****
**** * *****
      ADDL DESC COUNT: ***  AVG:  ***.** ***.** ***.**  PROCESS *****

SAE DELETE

                                BATCH ***

                                OPERATION SEQ aaA4 *****
PRESS ENTER TO DELETE OPERATION AND ADDL DESCRIPTIONS
                                USE ROLL UP/DOWN
                                F06 SAE CHANGE
                                F07 SAE DELETE
                                F08 SAE ADD
                                F10 ADDL DESCRIPTION
                                F11 MILESTONE ENTRY
                                F19 RETURN TO SELECT
                                F24 STATUS

```

What to do

- To delete an operation from the routing, press **Enter**. To confirm the transaction, press **Enter** again.
- To cancel what you've changed on this display, use **F19**. (Make sure that you have completed all same-as-except transactions for the new parent item.) Go to display AMEU71.
- To delete another operation from the routing you copied, use **F07**.
- To add an operation to the routing you copied, use **F08**. Go to display AMEU24.
- To add, change, or delete an additional description for the routing you copied, use **F10**. Go to display AMEU27.
- To define or remove a milestone group for the routing you copied, use **F11**. Go to display AMEU28.
- To end the session or review the status of Routing file, use **F24**. Go to display AMEU26.

Function keys

USE ROLL UP/DOWN allows you to scroll up and down through the list of operations on the displays.

F06 SAE CHANGE causes display AMEU22 to appear.

F07 SAE DELETE causes display AMEU23 to appear again with **OPERATION SEQ** field set to blanks. Use this function key when you have entered the operation sequence number and decide not to delete the operation.

F08 SAE ADD causes display AMEU24 to appear.

F10 ADDL DESCRIPTION causes display AMEU27 to appear.

F11 MILESTONE ENTRY causes display AMEU28 to appear.

F19 RETURN TO SELECT ignores the data you just entered and causes display AMEU71 to appear again.

F24 STATUS causes display AMEU26 to appear.

Fields

All of the fields on the top half of the display are informational only.

PARENT ITEM (ITNBR). The number of the new parent item you entered on display AMEU21.

For a description of the remaining fields on the top half of this display, see “AMEU21—Routing File Maintenance (SAE Header)”.

BATCH. The number of the batch to which you are currently attached.

OPERATION SEQ (Operation Sequence Number) (OPSEQ). Required. Type in the operation sequence number of the operation you want to delete.

AMEU24—Routing File Maintenance (SAE Add)

Use this display to add operations to the routing you copied using display AMEU21.

This display appears if you select **F08 (SAE Add)** on any of the following displays: AMEU22, AMEU23, AMEU27, or AMEU28.

```

DATE **/**/**           ROUTING FILE MAINTENANCE           SAE ADD           AMEU24  **
PARENT ITEM *****
OPER M           ---RUN---  --SETUP--  MOVE OPER
SEQ S DESCRIPTION           FAC TBC MACH LABOR  TIME CREW  DAYS STATUS TOOL
**** * *****
ADDL DESC COUNT: ***     AVG: ***.*** ***.*** ***.***     PROCESS *****
**** * *****
ADDL DESC COUNT: ***     AVG: ***.*** ***.*** ***.***     PROCESS ***** +

SAE ADD OPERATION                                     BATCH ***
OPERATION SEQ   aaA4           DESCRIPTION aaaaaaaaaaaaaaaaaA20  PRINT FLAG  A
FACILITY ID     aaaA5           TIME BASIS  A  OUTSIDE COST nnnnnnnnnnnn.nnnnnnnn
RUN MACHINE     nnn.nn            SETUP LABOR TIME nnn.nn    REPORT POINT  n
RUN LABOR       nnn.nn            SETUP CREW SIZE  nn         OPER RUN QTY  nnnn.nnn
MOVE DAYS       nn.nn              OPER STATUS CODE A2         F06 SAE CHANGE
TOOL            aaaaA6           STANDARD YIELD    n.nnn      F07 SAE DELETE
PROCESS SHEET   aaaaA6           CURRENT YIELD     n.nnn      F08 SAE ADD
INV TRAN CODE   A2              SELECT CODE       A2         F10 ADDL DESCRIPTION
OPER RUN QTY   nnnn.nnn            USE ROLL UP/DOWN F11 MILESTONE ENTRY
                                           F19 RETURN TO SELECT
                                           F24 STATUS
    
```

What to do

- To add an operation from the routing, press **Enter**.
- To copy another existing routing, use **F19**. Go to display AMEU71.
- To delete an operation from the routing you copied, use **F07**. Go to display AMEU23.
- To add an operation to the routing you copied, use **F08**.
- To add, change, or delete an additional description for the routing you copied, use **F10**. Go to display AMEU27.
- To define or remove a milestone group for the routing you copied, use **F11**. Go to display AMEU28.
- To end the session or review the status of Routing file, use **F24**. Go to display AMEU26.

Function keys

USE ROLL UP/DOWN allows you to scroll up and down through the list of operations on the displays.

F06 SAE CHANGE causes display AMEU22 to appear.

F07 SAE DELETE causes display AMEU23 to appear.

F08 SAE ADD causes display AMEU24 to appear again with **OPERATION SEQ** field (and any other fields you may have entered) returned to blanks. Use this function key if you decide not to add this operation.

F10 ADDL DESCRIPTION causes display AMEU27 to appear.

F11 MILESTONE ENTRY causes display AMEU28 to appear.

F19 RETURN TO SELECT ignores the information you just entered and causes display AMEU71 to appear again.

F24 STATUS causes display AMEU26 to appear.

Fields

PARENT ITEM (ITNBR). The number of the new parent item you entered on display AMEU21.

For a description of the remaining fields on the top half of this display, see “AMEU21—Routing File Maintenance (SAE Header)”.

BATCH. The number of the batch to which you are currently attached.

For a description of the remaining fields on the bottom half of this display, see “AMEU72—Routing File Maintenance (Add/Review)”.

AMEU26—Routing File Maintenance (Batch Status)

Use this display to end the current Routing file maintenance session and to review the status of the routing transactions, the description transactions, and the batch to which you are currently attached.

This display appears when you select a closed, suspended, or active batch on display AMEU61 or if you select **F24** on any of the following displays: AMEU21, AMEU22, AMEU23, AMEU24, AMEU27, or AMEU28.

```

DATE **/**/**          ROUTING FILE MAINTENANCE          BATCH STATUS AMEU26  **
----- BATCH STATISTICS -----                          BATCH ***

- ROUTING TRANSACTIONS -
ADDS ENTERED           *****
CHANGES ENTERED      *****
DELETES ENTERED       *****
SAME-AS-EXCEPT HEADER *****
ROUTING DELETES ENTERED ****
MILESTONE TRANSACTIONS *****

- DESCRIPTION TRANSACTIONS -
ADDS ENTERED           *****
CHANGES ENTERED      *****
DELETES ENTERED       *****
MULTI DELETES ENTERED *****

- BATCH TOTALS -
TOTAL TRANSACTIONS    *****

                                F04 UPDATE NOW
                                F20 DELETE BATCH
                                F23 SUSPEND BATCH
                                F24 CLOSE BATCH

```

What to do

- To close the batch and update the batch immediately, use **F04**. Your work station is not available until the update is complete. The application schedules the reports for printing.
- To delete the batch, use **F20**. You must use **F20** twice to confirm the delete. The application schedules the reports for printing.
- To suspend the batch, use **F23**.
- To close the batch and schedule a job to update the batch, use **F24**. The application schedules the reports for printing.

The File Maintenance menu (AMEM05) appears.

Function keys

F04 UPDATE NOW closes the batch and processes it immediately for update to the Routing file. Your work station is attached to the Routing File Load and Maintenance program (AMEB4) until completion of all updates. Upon completion, the File Maintenance menu (AMEM05) appears again.

F20 DELETE BATCH schedules a job to delete the batch and causes the File Maintenance menu (AMEM05) to appear again.

Use **F20** again to confirm the batch deletion.

[Contents](#)

[Index](#)

F23 SUSPEND BATCH suspends your batch and causes the File Maintenance menu (AMEM05) to appear again.

F24 CLOSE BATCH schedules a job to process the closed batch and causes the File Maintenance menu (AMEM05) to appear again.

Note: You should suspend the batch using **F23** and update the Routing file at a later time to avoid conflicts with any other jobs.

Fields

See “AMEU77—Routing File Maintenance (Batch Status)” for descriptions of the fields that appear on this display. All of the fields on this display are informational only.

AMEU27—Routing File Maintenance (SAE Addl Desc Maint)

Use this display to add, change, or delete individual or multiple descriptions for any of the operations of the routing you copied using display AMEU21.

This display appears when you select **F10 ADDL DESCRIPTION** on any of the following displays: AMEU22, AMEU23, AMEU24, or AMEU28.

If you choose action code A (add) and press **Enter**, an add transaction is created and this display appears again. You can add, change, or delete another description for the same routing operation.

If you choose action code C (change) and press **Enter**, this display appears again with any errors that are found. You can correct the operation sequence number or line number, if required. If the operation sequence number and line numbers have no errors and you press **Enter**, this display appears again, and you can change the additional description field. When you press **Enter** again, a change transaction is created and this display appears again. You can add, change, or delete another description for the same routing operation.

If you choose action code D (delete) and press **Enter**, this display appears again with any errors that are found. You can correct the operation sequence number and line number, if required. If the operation sequence number and line number have no errors and you press **Enter**, this display appears again for you to confirm the delete. When you press **Enter** again, the delete is confirmed and a delete transaction is created. The display appears again, and you can add, change, or delete another description for the same routing operation.

If you choose action code M (multiple delete) and press **Enter**, this display appears again for you to confirm the delete. When you press **Enter** again, the delete is confirmed and a delete transaction is created to delete all description records for this routing operation. The display appears again, and you can add, change, or delete another description for the same routing operation.

DATE **/**/**	ROUTING FILE MAINTENANCE	SAE ADDL DESC MAINT	AMEU27 **
ITEM *****	OPER SEQ ****	FACILITY ID *****	
OPERATION	DESCRIPTION *****		
LINE	ADDITIONAL DESCRIPTION		
***	*****		
***	*****		
***	*****		
***	*****		
***	*****		
***	*****		
***	*****		
***	*****		
***	*****		
***	*****		
***	*****		
***	*****		+
ADDITIONAL DESCRIPTIONS			
OPER SEQ LINE		USE ROLL UP/DOWN	
aaA4 nnn		F03 PREV SCREEN	
ACTION A-ADD, C-CHANGE, D-DELETE, M-MULTIPLE DELETE		F06 SAE CHANGE	
A	aaaaaaaaaaaaaaaaaaaaaaaaaaaaaaaaA40	F07 SAE DELETE	
PRESS ENTER TO DELETE ALL DESCRIPTION FOR OPERATION		F08 SAE ADD	
		F19 RETURN TO SELECT	
		F24 STATUS	

What to do

- To add, change, or delete an additional description for the routing you copied, type in the information requested and press **Enter**.
- To change an operation in the routing you copied, use **F06**. Go to display AMEU22.
- To delete an operation from the routing you copied, use **F07**. Go to display AMEU23.
- To add an operation to the routing you copied, use **F08**. Go to display AMEU24.
- To copy another existing routing or to continue with Routing file maintenance, use **F19**. Go to display AMEU71.
- To close the batch and schedule a job to update the batch, use **F24**. The application schedules the reports for printing.

Function keys

USE ROLL UP/DOWN allows you to scroll up and down through the list of operations on the displays.

F03 PREV SCREEN causes one of the following displays to appear again: AMEU22, AMEU23, or AMEU24.

F06 SAE CHANGE causes display AMEU22 to appear.

F07 SAE DELETE causes display AMEU23 to appear.

F08 SAE ADD causes display AMEU24 to appear.

F19 RETURN TO SELECT ignores the data you just entered and causes display AMEU71 to appear again.

F24 STATUS causes display AMEU26 to appear.

Fields

ITEM (ITNBR). The number of the new parent item you entered on display AMEU21.

OPER SEQ (Operation Sequence Number) (OPSEQ). The number of the routing operation whose descriptions you want to add, change, or delete.

FACILITY ID (WKCTR). The facility where this operation is performed.

OPERATION DESCRIPTION (OPDSC). A short description of this operation.

LINE (Description Line Number) (DSQNO). The line number of the routing operation's additional description.

ADDITIONAL DESCRIPTION (ADDSC). The additional descriptive information for a routing operation.

OPER SEQ (Operation Sequence Number) (OPSEQ). Required for action codes A, C, and D. Type in the routing operation sequence number for the additional description you want to add, change, or delete.

LINE (Description Line Number) (DSQNO). Required. Type in the line number of the additional description you want to add, change, or delete.

ACTION (Action Code) (ACTCD). Required. Type in one of the following codes to choose the type of maintenance you want to do:

- A** Add a new description record for this operation
- C** Change an existing description for this operation
- D** Delete one additional description for this operation
- M** Delete all additional descriptions for this operation.

Additional Description (ADDSC). This field appears to the right of the **ACTION** field and has no heading. In this field, you can type in the new text for the description you are adding or changing.

AMEU28—Routing File Maintenance (SAE MS-MNT)

Use this display to enter a transaction to define or delete a milestone group for a routing you copied using display AMEU21.

This display appears when you use **F11 MILESTONE ENTRY** on any of the following displays: AMEU22, AMEU23, or AMEU24.

```

DATE **/**/**          ROUTING FILE MAINTENANCE          SAE MS-MNT    AMEU28  **
PARENT ITEM *****
OPER M                ---RUN---  --SETUP--  MOVE OPER
SEQ S DESCRIPTION    FAC  TBC MACH  LABOR  TIME CREW  DAYS STATUS TOOL
**** * *****
**** * ADDL DESC COUNT: ***  AVG: ***.** ***.** ***.**  PROCESS *****
**** * *****
**** * ADDL DESC COUNT: ***  AVG: ***.** ***.** ***.**  PROCESS ***** +

MILESTONE
ACTION CODE DEFINE <1>                                BATCH ***
-or- REMOVE <2>  A

BEGINNING OPERATION    aaA4                                USE ROLL UP/DOWN
ENDING   OPERATION     aaA4                                F03 PREV SCREEN
                                                F06 SAE CHANGE
                                                F07 SAE DELETE
                                                F08 SAE ADD
                                                F10 ADDL DESCRIPTION
                                                F19 RETURN TO SELECT
                                                F24 STATUS

MILESTONE TYPE <F,J>  A

```

What to do

- To define or remove a milestone group for the routing you copied, type in the information requested and press **Enter**.
- To change an operation in the routing you copied, use **F06**. Go to display AMEU22.
- To delete an operation from the routing you copied, use **F07**. Go to display AMEU23.
- To add an operation to the routing you copied, use **F08**. Go to display AMEU24.
- To add, change, or delete an additional description to the routing you copied, use **F10**. Go to display AMEU27.
- To cancel what you have done on this display, to copy another existing routing, or to continue with Routing file maintenance, use **F19**. Go to display AMEU71.
- To close the batch and schedule a job to update the batch, use **F24**. Go to display AMEU26.

Function keys

USE ROLL UP/DOWN allows you to scroll up and down through the list of operations on the displays.

F03 PREV SCREEN causes the display you came from to appear again (either AMEU22, AMEU23, or AMEU24).

F06 SAE CHANGE causes display AMEU22 to appear.

F07 SAE DELETE causes display AMEU23 to appear again with OPERATION SEQ field set to blanks. Use this function key when you have entered the operation sequence number and decide not to delete the operation.

F08 SAE ADD causes display AMEU24 to appear.

F10 ADDL DESCRIPTION causes display AMEU27 to appear.

F19 RETURN TO SELECT ignores the data you just entered and causes display AMEU71 to appear again.

F24 STATUS causes display AMEU26 to appear.

Fields

PARENT ITEM (ITNBR). The number of the new parent item you entered on display AMEU21.

For a description of the remaining fields on the top half of this display, see “AMEU21—Routing File Maintenance (SAE Header)”.

ACTION CODE DEFINE <1> -or- REMOVE <2> (ACTCD). Type in the code to indicate if you want to define or remove a milestone group:

- 1 Define a new milestone group
- 2 Remove a milestone group.

BEGINNING OPERATION (BEGOP). To define or remove a milestone group, type in the operation sequence number that identifies the detailed operation for that item that is the first operation of the milestone group.

ENDING OPERATION (ENDOP). To define a milestone group, type in the operation sequence number that identifies the detailed operation for that item that is the last operation of the milestone group.

MILESTONE TYPE <F,J> (MSTYP). To define a milestone group, type in the code to indicate if the milestone group is for a job shop environment or for a flow shop environment:

- J Job shop
- F Flow shop.

AMEU81—Routing File Maintenance (Review)

Use this display to review all transactions in the batch (including additional detail for Add, Change, SAE Add, or SAE Change transactions) and, if required, to delete the transaction.

This display appears if you select **F05 REVIEW** on display AMEU71.

Note: If a transaction has an error, it must first be deleted (action code D). You can then return to display AMEU71 and enter the corrected transaction.

```

DATE **/**/**          ROUTING FILE MAINTENANCE          REVIEW          AMEU81  **
                        OPER
TRAN NO  TRANSACTION TYPE  ITEM              SEQ      FAC  LINE  OLD ITEM
*****  *****
*****  *****
*****  *****
*****  *****
*****  *****
*****  *****
*****  *****
*****  *****
*****  *****
*****  *****
*****  *****
*****  *****
*****  *****
*****  *****
*****  *****
*****  *****

REVIEW                                                    BATCH  ***

ACTIONS                ENTER--
A  ADDITIONAL DETAIL      ACTION  A
D  DELETE                 TRAN NO  nnnnnnn

                        PRESS ENTER TO DELETE TRANSACTION

                        USE ROLL UP/DOWN
                        F19 RETURN TO SELECT
                        F24 STATUS
  
```

What to do

- To review additional detail for a transaction shown on the top half of the display, type in **A** and the transaction number and press **Enter**. Go to display AMEU82.
- To delete a transaction, type in **D** and the transaction number field and press **Enter**. To confirm the deletion, press **Enter** again.
- To end the session or review the status of Routing file, go to display AMEU83. Use **F24**.

Function keys

USE ROLL UP/DOWN allows you to scroll up and down through the list of operations on the displays.

F19 RETURN TO SELECT ignores the data you just entered and causes display AMEU71 to appear again.

F24 STATUS causes display AMEU83 to appear.

Fields

TRAN NO (Transaction Number). The application generated numbers used to select individual transactions for deletion or additional detail.

TRANSACTION TYPE. The type of transaction:

- Add Routing
- Change Routing
- Delete Routing
- Routing Delete
- Add Description
- Change Description
- Delete Description
- Delete Routing Description
- Sae Header
- Sae Change
- Sae Delete
- Sae Add
- Sae Additional Description Maintenance.

ITEM (ITNBR). The number of the parent item whose routing is affected by this transaction.

OPER SEQ (Operation Sequence Number) (OPSEQ). The sequence number of the operation affected by this transaction.

FAC (Facility ID) (WKCTR). The unique code that identifies the area where this operation takes place. If the time basis code is C, the ID represents a vendor (or group of vendors).

LINE (Description Line Number (DSQNO). The line number of the routing operation's additional description.

OLD ITEM. The old parent item number involved in the SAE Header transaction.

ACTION. Required. Type in either **A** to see additional detail or **D** to delete a transaction.

TRAN NO (Transaction Number). Required. Type in the number of the transaction you want to delete or for which you want to see additional detail. The transaction numbers appear in the far left column of the display. You can request additional detail for transactions having transaction types of add, change, SAE add, or SAE change.

BATCH. This field shows the batch number to which you are currently attached.

AMEU82—Routing File Maintenance (Review)

Use this display to review the detail for the add, change, SAE add, and SAE change for the routing operation transaction you selected on display AMEU81.

This display appears when you type action code A (additional detail) for an add change, SAE add, or SAE change transaction on display AMEU81.

```

DATE **/**/**          ROUTING FILE MAINTENANCE          REVIEW          AMEU82  **
                                OPER
TRAN NO. TRANSACTION TYPE  ITEM                      SEQ    FAC    BATCH
*****  *****          *****          ****  *****  ***

DESCRIPTION *****
TIME BASIS CODE ***** *
OUTSIDE COST ***** *****
RUN MACHINE ***** **
SETUP LABOR HOURS ***** **
RUN LABOR ***** **
SETUP CREW SIZE ***** **
TOOL ***** **
PRINT FLAG ***** *
INTERMEDIATE REPORT POINT ***** *
OLD OPERATION SEQUENCE ***** *****

                                OPERATION STATUS CODE          **
                                PROCESS SHEET NUMBER          *****
                                STANDARD YIELD          *.***
                                CURRENT YIELD          *.***
                                INV. TRN. CODE          **
                                MOVE DAYS          **. **
                                SELECT CODE          **
                                OPER RUN QTY          ****.***

                                OLD FACILITY ID          *****

                                PRESS ENTER TO CONTINUE
    
```

What to do

Press **Enter** to return to display AMEU81 when you have completed reviewing the additional detail for this transaction.

Function keys

None.

Fields

All of the following fields on this display are informational only:

TRAN NO. The application generated numbers used to select individual transactions for deletion or additional detail.

TRANSACTION TYPE. The type of transaction:

- Add Routing
- Change Routing
- Delete Routing
- Routing Delete
- Add Description
- Change Description
- Delete Description

- Delete Routing Description
- Sae Header
- Sae Change
- Sae Delete
- Sae Add
- Sae Additional Description Maintenance.

ITEM (ITNBR). The number of the parent item whose routing is affected by this transaction.

OPER SEQ (Operation Sequence Number) (OPSEQ). The sequence number of the operation affected by this transaction.

FAC (Facility ID) (WKCTR). The unique code that identifies the area where this operation takes place. If the time basis code is C, this ID represents a vendor (or group of vendors).

BATCH. The number of the batch to which you are currently attached.

DESCRIPTION (OPDSC). The description of the task performed during the operation.

TIME BASIS CODE (TBCOD). Indicates one of the following codes which are used to develop standard run labor time, run machine time, and run labor costs:

blank	Hours per unit
1	Hours per 10 units
2	Hours per 100 units
3	Hours per 1000 units
4	Hours per 10,000 units
P	Pieces per hour
M	Minutes per piece
H	Hours per lot
C	Cost per piece.

OUTSIDE COSTS (OSCS). The cost per piece charged by the vendor to produce the item. This field is used when the time basis code is C.

RUN MACHINE (Run Machine Time) (RUNMC). When adjusted by the time basis code (TBC), this is the time in hours or minutes that the machine in the associated facility is expected to run to produce one or more units (depending on the TBC) of the associated item. If the time basis code is C, the run machine time is not adjusted. PDM product costing also uses this field to calculate standard and current labor overhead content this-level in the associated Item Master B-record.

SETUP LABOR HOURS (SULHR). The time in hours or minutes of labor to setup this operation. PDM product costing also uses this field to calculate standard and current labor and labor overhead content this-level in the associated Item Master B-record.

RUN LABOR (Run Labor Time) (RUNLB). When adjusted by the time basis code in this record, this is the time in hours or minutes of labor expected to produce one or more units (depending on the TBC) of the associated item. If the time basis code is C, indicating an outside operation, no value appears in this field. PDM product costing also uses this field to calculate standard and current labor and labor overhead content this-level in the associated Item Master B-record.

SETUP CREW SIZE (SUCSZ). The number of people in the crew that does the setup of this operation. If the time basis code is C, this field should show 1. PDM product costing uses this field to calculate standard and current labor overhead content this-level in the associated Item Master B-record. The default is 1. The setup machine time is calculated as setup labor time divided by setup crew size.

TOOL (Tool Number) (RTOOL). The number for a tool or tools needed to perform the operation.

PRINT FLAG (PRTFG). Type in one of the following codes to indicate whether you want this operation to appear on the dock-to-stock traveller:

- Y** This operation should appear on the dock-to-stock traveller.
- N** This operation should not appear on the dock-to-stock traveller.

INTERMEDIATE REPORT POINT (IRCOD). This field appears if Repetitive Production Management (REP) is interfacing and this is not a purchased item. It contains a code that shows whether reporting is required for this operation when the item appears on a REP schedule. Valid codes are:

- 1** Reporting is required
- 0** Reporting is not required; backflushing occurs.

OLD OPERATION SEQUENCE (Old Operation Sequence Number) (OLDSQ). The old sequence value if the transaction included a change in the OPER SEQ field.

OPERATION STATUS CODE (OPSTC). Indicates one of the following codes for this operation:

- 00** Inactive
- 10** Active.

PROCESS SHEET NUMBER (PRONO). The number used to identify a user document that contains detailed instructions concerning processes required within the operation.

STANDARD YIELD (Standard Operation Yield) (SYTOP). Indicates a percentage that represents the budgeted or annual estimate of the amount of this parent item expected to remain in the production process at the end of an operation compared to the amount available at the start of the operation. This percentage is used for standard costing. The default is 1.000 (100%).

CURRENT YIELD (Current Operation Yield) (CYTOP). Indicates a percentage that represents today's or the near-term future expected amount of this parent item that remains in the production process at the end of an operation compared to the amount available at the start of the operation. This percentage is used for current costing, scheduling, and materials requirements. The default is 1.000 (100%).

INV. TRN. CODE (TCODE). Indicates what type of transaction is to be processed during purchase order receipt entry, in purchasing, when receiving routings are used.

- VA** Vendor acknowledgment
- RD** Receipt to dock
- RI** Receipt to inspection
- RP** Stock receipt
- PQ** Purchase quantity control.

[Contents](#)

[Index](#)

MOVE DAYS (MOVTM). The planned time in days required to move an order to this operation from its last location. If the time basis code is C, this field shows the total lead time from completion of the previous operation to receipt back from the vendor. This value is used in PC&C manufacturing order scheduling routines.

SELECT CODE (SELNO). Type a number from 01 to 99 to identify the unique alternate routing identification for this operation.

OPER RUN QTY (PUNIT). The standard quantity of the end item you are processing at this facility.

OLD FACILITY ID (Old Facility ID) (OLDWC). The old facility ID if the transaction included a change in the **FAC** field.

AMEU83—Routing File Maintenance (Batch Status)

Use this display to end the current Routing file maintenance session and to review the status of the routing transactions, the description transactions, and the batch to which you are currently attached.

This display appears when you select a closed, suspended, or an active batch on display AMEU61, or if you select **F24 STATUS** on display AMEU81.

```

DATE **/**/**          ROUTING FILE MAINTENANCE          BATCH STATUS AMEU83  **
----- BATCH STATISTICS -----                          BATCH ***

- ROUTING TRANSACTIONS -
ADDS ENTERED           *****
CHANGES ENTERED      *****
DELETES ENTERED       *****
SAME-AS-EXCEPT HEADER *****
ROUTING DELETES ENTERED ***
MILESTONE TRANSACTIONS *****

- DESCRIPTION TRANSACTIONS -
ADDS ENTERED           *****
CHANGES ENTERED      *****
DELETES ENTERED       *****
MULTI DELETES ENTERED *****

- BATCH TOTALS -
TOTAL TRANSACTIONS    *****

                                F04 UPDATE NOW
                                F20 DELETE BATCH
                                F23 SUSPEND BATCH
                                F24 CLOSE BATCH

```

What to do

- To close the batch and update the batch immediately, use **F04**. Your work station is not available until the update is complete. The application schedules the reports for printing.
- To delete the batch, use **F20**. You must use **F20** twice to confirm the delete. The application schedules the reports for printing.
- To suspend the batch, use **F23**.
- To close the batch and schedule a job to update the batch, use **F24**. The application schedules the reports for printing.

The File Maintenance menu (AMEM05) appears.

Function keys

F04 UPDATE NOW closes the batch and processes it immediately for update to the Routing file. Your work station is attached to the Routing File Load and Maintenance program (AMEB4) until completion of all updates. Upon completion, the File Maintenance menu (AMEM05) appears again.

F20 DELETE BATCH Schedules a job to delete the batch and causes the File Maintenance menu (AMEM05) to appear again.

Use **F20** again to confirm the batch deletion.

[Contents](#)

[Index](#)

F23 SUSPEND BATCH suspends your batch and causes the File Maintenance menu (AMEM05) to appear again.

F24 CLOSE BATCH Schedules a job to process the closed batch and causes the File Maintenance menu (AMEM05) to appear again.

Note: You should suspend the batch using **F23** and update the Routing file at a later time to avoid conflicts with any other jobs.

Fields

See “AMEU77—Routing File Maintenance (Batch Status)” for descriptions of the fields on this display. These fields are informational only.

AMEU84—Routing File Maintenance (Review)

Use this display to review the detail (add, change, SAE add, or SAE change) for the routing operation description transaction you selected on display AMEU81.

This display appears when you type action code A (additional detail) for an add, change, SAE add, or SAE change transaction on display AMEU81.

DATE	**/**/**	ROUTING FILE MAINTENANCE	REVIEW	AMEU84	**
TRAN NO	TRANSACTION TYPE	ITEM	OPER SEQ	FAC	BATCH
*****	*****	*****	****	*****	***
LINE	ADDITIONAL DESCRIPTION				
***	*****				
PRESS ENTER TO CONTINUE					

What to do

Press **Enter** to return to display AMEU81 when you have completed reviewing the additional detail for this transaction.

Function keys

None.

Fields

TRAN NO (Transaction Number). The application generated numbers used to select individual transactions for deletion or additional detail.

TRANSACTION TYPE. The type of transaction: add, change, SAE add, or SAE change.

ITEM (Item Number) (ITNBR). The number of the parent item whose routing is affected by these transactions.

OPER SEQ (Operation Sequence Number) (OPSEQ). The sequence number of the operation affected by this transaction.

[Contents](#)

[Index](#)

FAC (Facility ID) (WKCTR). The unique code that identifies the area where this operation takes place. If the time basis code is C, this ID represents a vendor (or group of vendors).

BATCH. The batch number to which you are currently attached.

LINE (Description Line Number) (DSQNO). The line number of the routing operation's additional description.

ADDITIONAL DESCRIPTION (ADDSC). The additional descriptive information for a routing operation.

AMEU85—Routing File Maintenance (Review)

Use this display to review the SAE milestone group transactions for the routing you selected on display AMEU81.

This display appears when you type action code A (additional detail) for a milestone group transaction on display AMEU81.

```
DATE **/**/**          ROUTING FILE MAINTENANCE          REVIEW    AMEU85  **
TRAN NO  TRANSACTION TYPE  ITEM
*****  *****          *****

ACTION DEFINE <1> REMOVE <2>      *
BEGINNING OPERATION                ****
ENDING OPERATION                   ****
MILESTONE GROUP TYPE <F,J>         *
```

PRESS ENTER TO CONTINUE

What to do

Press **Enter** to return to display AMEU81 when you have completed reviewing the additional detail for this transaction.

Function keys

None.

Fields

TRAN NO (Transaction Number). The application generated numbers identifying individual transactions for milestone group define/remove.

TRANSACTION TYPE. Indicates the type of transaction:

- Milestone D** Define
- Milestone R** Remove.

ITEM (Item Number) (ITNBR). The number of the parent item whose routing is affected by these transactions.

ACTION CODE DEFINE <1> -or- REMOVE <2> (ACTCD). Indicates whether the milestone group was defined or removed:

- 1** Define a new milestone group
- 2** Remove a milestone group.

BEGINNING OPERATION (BEGOP). The operation sequence number that identifies the detailed operation that is the first operation of the milestone group.

ENDING OPERATION (ENDOP). Appears only for a Define transaction. The operation sequence number that identifies the detailed operation for that item that is the last operation of the milestone group.

MILESTONE GROUP TYPE <F,J> (MSTYP). Indicates if the milestone group is for a flow shop environment or for a job shop environment:

- F** Flow shop
- J** Job shop.

and so on, with 0010 as the first operation. Using multiples of 10 allows you to insert operations such as 0012, 0023, and 0024 later.

MS (Milestone) (MLSTN). The milestone type for a suboperation belonging to a milestone group:

- B** The first suboperation of a milestone group with no activity reported.
- S** A suboperation of a milestone group that is between the first and the last suboperation.
- J** The last suboperation of a milestone group for a job shop type of milestone group.
- F** The last suboperation of a milestone group for a flow shop type of milestone group.

DESCRIPTION (OPDSC). A short description of the task performed during this operation.

FAC (Facility ID) (WKCTR). The ID (user-assigned) of the production facility where this operation is performed.

TBC (Time Basis Code) (TBCOD). This code is used to develop standard run labor hours, run machine hours, and run labor costs.

- blank** Hours per unit
- 1** Hours per 10 units
- 2** Hours per 100 units
- 3** Hours per 1,000 units
- 4** Hours per 10,000 units
- P** Pieces per hour
- H** Hours per lot
- M** Minutes per piece
- C** Cost per piece (used for outside operations).

Note: M applies to all time fields entered; all other time basis codes apply only to run machine and run labor.

RUN MACH (Run Machine) (RUNMC). The run machine time for this operation. When adjusted by the time basis code, this is the time in hours or minutes that the machine in the associated facility is expected to run to produce one or more units (depending on the TBC) of the associated item. If the time basis code is C, the run machine time is not adjusted. PDM product costing also uses this field to calculate standard and current labor overhead content this level in the associated Item Master B-record.

RUN LABOR (RUNLB). The run labor time for this operation. When extended by the time basis code, the field shows the expected hours or minutes of run labor necessary to produce one or more units (depending on the TBC) of this item. If the time basis code is C, which indicates an outside operation, no value appears in this field. If the time basis code is P, labor represents the quantity per hour. If the cost technique code is R, PDM product costing uses this field to determine the run labor portion of standard and current labor and labor overhead content this-level in the associated Item Master B-record.

SETUP TIME (SULHR). The setup labor time for this operation. PDM product costing uses this field to calculate standard and current labor and labor overhead content this-level in the associated Item Master B-record.

SETUP CREW (SUCSZ). The number of people in the crew that does the setup of this operation. If the time basis code is C, this field should show 1. PDM product costing also uses this field to calculate standard and current overhead content this-level in the associated Item Master B-record. The default is 1. The setup machine hours are calculated as setup labor hours divided by setup crew size.

MOVE DAYS (MOVTM). Indicates the planned time, in days, required to move an order to this operation from its last location. If the time basis code is C, this field shows the total lead time from completion of the previous operation to receipt back from the vendor. This value is used in PC&C manufacturing order scheduling routines.

OP ST (Operation Status Code) (OPSTC). Indicates one of the following operation status codes for this operation:

00 Inactive
10 Active.

BCH (Batch). The batch number of each transaction.

TRN TYP (Transaction Type) (TTYPE). Indicates the type of transaction for each operation.

ADD Add, additional description add, SAE header, or SAE add
CHG Change, additional description change, or SAE change.

Note: Any operations of the routing with any pending add, change, delete, routing delete, additional description add, change, delete, and multiple delete, and same-as-except (SAE) transactions are highlighted. Any pending transactions with errors are in reverse image.

Option 5. Item Base Price (AMEM05)

Use this option to create, maintain, review, or delete item base prices. You can also add a new item base price to the Item Base Price file.

How to start Item Base Prices

In Customer Order Management

Menu	Option
COM Main Menu (AMBM00)	Option 6
COM File Maintenance Menu (AMBM60)	Option 3
COM Pricing Maintenance Menu (AMBM63)	Option 1

In Product Data Management

Menu	Option
PDM Main Menu (AMEM00)	Option 4
PDM File Maintenance Menu (AMEM05)	Option 5

Example: Item Base Prices

Before you begin Item Base Prices maintenance, you need the item number associated with the item you want to maintain.

To display the list of item base prices, go to the Display Item Base Prices panel (AMBC2DFR). In COM, this is the first panel to appear after you select the **Item Base Prices** option on the Pricing Maintenance menu. In PDM, after you choose the **Item Base Price** option, the Edit Item Base Prices panel appears. The Display Item Base Prices panel does not appear in PDM.

To change an existing item base price, use **F6=Edit** on the Display Item Base Prices panel. This takes you to the Edit Item Base Prices panel (AMVB5EFR). When the Edit Item Base Prices panel first appears, it is in Change mode. Move the cursor to the field you want to change and type the new information. When you finish typing the changes, press **Enter**. This causes the changes to be accepted by the system.

Note: If you want to cancel the changes you've made and back out, use either **F3=Exit** or **F12=Cancel** before you press **Enter**. Once you press **Enter**, the changes are committed to the system.

To add a new item base price, use **F6=Add** on the Edit Item Base Prices panel. This causes the Edit Item Base Prices panel to change to Add mode. Type in the new item and base price, then press **Enter**.

To delete an item base price, go to the Edit Item Base Prices (Change) panel and type **4** next to the item number you want to delete.

To display item base prices

In COM, when you select option 1 of the Pricing Maintenance menu, the Display Item Base Prices panel appears. In PDM, you do not see the following panel.

```
AMBC2DFR                      Display Item Base Prices                      DISPLAY
Position to Item number . . . . .
Effective date . . . . .
Base price . . . . .
Pricing U/M . . . . .

Item number      Effective date      Base price      Pricing U/M      Item price class
BATTERY          5/07/93              10.000         EA
12 VOLT BATTERY
BATTERY          6/24/93              154.000        EA
12 VOLT BATTERY
BATTERY          6/30/93              50.000         EA      TEST
12 VOLT BATTERY
BINSLRC          6/24/93              .000           GL
BLUE INDDOR/OUT SALRIUM CPT
BINSLRC          9/01/93              .000           GL
BLUE INDDOR/OUT SALRIUM CPT      +

F3=Exit      F6=Edit      F7=Backward      F8=Forward      F11=Job status
F12=Cancel   F21=Print
```

To change, add, or delete item base prices, use **F6=Edit**. The Edit Item Base Prices panel appears in Change mode.

To change an item base price

To change an item base price, move the cursor to the field you want to update and type the new information. When you finish making changes, press **Enter**. Pressing **Enter** causes the system to accept the changes. If you want to cancel what you've done and back out, use either **F3=Exit** or **F12=Cancel** before you press **Enter**.

```

AMVB5EFR                               Edit Item Base Prices                               CHANGE
Position to Item number . . . . .
Effective date . . . . .

Type options; press Enter.
4=Delete

Opt Item number      Effective   Base price      Pricing  Item price
                    date         .              U/M      class
BATTERY             50793          10.000         EA
12 VOLT BATTERY
BATTERY             62493          154.000        EA
12 VOLT BATTERY
BATTERY             63093          50.000         EA      TEST
12 VOLT BATTERY
BINSLRC             62493          .000           GL
BLUE INDDOR/OUT SALRIUM CPT
BINSLRC             90193          .000           GL
BLUE INDDOR/OUT SALRIUM CPT
+

F3=Exit      F4=Prompt   F6=Add      F7=Backward  F8=Forward
F11=Job Status  F12=Cancel  F21=Print

```

To add new item base prices

To add a new item base price, use **F6=Add** on the Edit Item Base Prices (Change) panel. The Edit Item Base Prices panel changes to Add mode.

Type the information you want to add and press **Enter** when finished.

```

AMVB5EFR                               Edit Item Base Prices                               ADD
Type information; press Enter.

Item number      Effective   Base price      Pricing  Item price
                 date         .              U/M      class
BATTERY          100193      140.000        EA      ITEM
                 72393       .000
                 72393       .000
                 72393       .000
                 72393       .000
+

F3=Exit      F4=Prompt   F6=Change   F7=Backward  F8=Forward
F11=Job Status  F12=Cancel

```

The Edit Item Base Prices panel returns to Change mode, and the new entry now appears in the listing.

```

AMVB5EFR                      Edit Item Base Prices                      CHANGE
Position to Item number . . . . .
Effective date . . . . .

Type options; press Enter.
4=Delete

Opt Item number      Effective   Base price      Pricing   Item price
                        date            class           U/M      class
BATTERY              50793          10.000          EA
12 VOLT BATTERY     62493          154.000         EA
12 VOLT BATTERY     63093          50.000          EA      TEST
12 VOLT BATTERY     100193         140.000         EA      ITEM
12 VOLT BATTERY     62493          .000            GL
BINSLRC
BLUE INDDOR/OUT SALRIUM CPT
+

F3=Exit      F4=Prompt   F6=Add      F7=Backward  F8=Forward
F11=Job Status  F12=Cancel F21=Print

```

To delete an item base price

To delete an item base price, type 4 next to one or more item numbers you want to delete.

```

AMVB5EFR                      Edit Item Base Prices                      CHANGE
Position to Item number . . . . .
Effective date . . . . .

Type options; press Enter.
4=Delete

Opt Item number      Effective   Base price      Pricing   Item price
                        date            class           U/M      class
BATTERY              50793          10.000          EA
12 VOLT BATTERY     62493          154.000         EA
12 VOLT BATTERY     63093          50.000          EA      TEST
12 VOLT BATTERY     100193         140.000         EA      TEST
4 BATTERY
12 VOLT BATTERY     62493          .000            GL
BINSLRC
BLUE INDDOR/OUT SALRIUM CPT
+

F3=Exit      F4=Prompt   F6=Add      F7=Backward  F8=Forward
F11=Job Status  F12=Cancel F21=Print

```

The system deletes the marked item(s) after you press **Enter**. The list appears again without the deleted information.

```
AMVB5EFR                      Edit Item Base Prices                      CHANGE
Position to Item number . . . . .
Effective date . . . . .

Type options; press Enter.
4=Delete

Opt Item number      Effective   Base price      Pricing   Item price
                    date          U/M            class
BATTERY              50793         10.000         EA
12 VOLT BATTERY     62493         154.000        EA
12 VOLT BATTERY     63093         50.000         EA      TEST
BATTERY              62493         .000           GL
BINSLRC              90193         .000           GL
BLUE INDDOR/OUT SALRIUM CPT
BINSLRC              90193         .000           GL
BLUE INDDOR/OUT SALRIUM CPT

F3=Exit      F4=Prompt   F6=Add      F7=Backward  F8=Forward
F11=Job Status  F12=Cancel  F21=Print
```

To end item base prices

When you finish the maintenance, use **F3=Exit**. If you are on the Edit Item Base Prices panel, you return to the Display Item Base Prices panel. Use **F3=Exit** again to return to the Pricing Maintenance menu.

Option 6. Item Foreign Language Description (AMEM05)

Use this option to create, maintain, review, or delete an item foreign language description. You can also add a new item foreign language description to the Item Foreign Language file.

How you start Item Foreign Language Description

In Customer Order Management

Menu	Option
COM Main Menu (AMBM00)	Option 6
COM File Maintenance Menu (AMBM60)	Option 2
COM Item Maintenance Menu (AMBM62)	Option 7

In Product Data Management

Menu	Option
PDM Main Menu (AMEM00)	Option 4
PDM File Maintenance Menu (AMEM05)	Option 6

Example: Item Foreign Language Description

When you begin Item Foreign Language Description maintenance, you need the item number associated with the foreign language item description you want to maintain.

Note: If you want to cancel the changes you've made and back out, use either **F3=Exit** or **F12=Cancel** before you press **Enter**. Once you press **Enter**, the changes are committed to the system.

To display foreign language item descriptions

After you select option 7 of the COM Item Maintenance Menu, the Display Item Foreign Languages panel appears.

```
AMBCBDFR                Display Item Foreign Languages                DISPLAY
Position to item . . . . .
language . . . . .

Item number      Language      Descriptions
BICYCLE         SPN          (10) BICICLETA
MEN'S, BLUE     SPN          (20) BICICLETA (HOMBRE)
                SPN          (30) BICICLETA, AZUL (PARA HOMBRE)
BICYCLE         GER          (10) FAHRRAD
MEN'S, BLUE     GER          (20) FAHRRAD (HERRENS)
                GER          (30) FAHRRAD, BLAU (HERRENS)

F3=Exit      F6=Edit      F7=Backward  F8=Forward   F11=Job Status
F12=Cancel   F21=Print
```

To change or delete foreign language item descriptions, use **F6=Edit**. The Edit Item Foreign Languages panel appears in Change mode.

To change foreign language item descriptions

To change a foreign language item description, move the cursor to the field you want to change and type in the new description. After you complete the changes, press **Enter**.

```
AMBDJEFR                      Edit Item Foreign Languages                      CHANGE

Position to item . . . . .
language . . .

Type options; press Enter.
4=Delete

Opt  Item number      Language      Descriptions
BICYCLE      SPN          (10) BICICLETA
MEN'S, BLUE  (20) BICICLETA (PARA HOMBRE)
              (30) BICICLETA, AZUL (PARA HOMBRE)
BICYCLE      GER          (10) FAHRRAD
MEN'S, BLUE  (20) FAHRRAD (HERRENS)
              (30) FAHRRAD, BLAU (HERRENS)

F3=Exit      F6=Add      F7=Backward  F8=Forward  F11=Job Status
F12=Cancel   F21=Print
```

To add a foreign language item description

To add a new foreign language description for an item, use **F6=Add** on the Edit Item Foreign Languages (Change) panel.

The Edit Item Foreign Languages panel appears in Add mode. Use this panel to enter a new foreign language item description.

```
AMBDJEFR                      Edit Item Foreign Languages                      ADD

Type information; press Enter.

Item number      Language      Descriptions
BICYCLE          FRN          (10) BICYCLETTE
MEN'S, BLUE      (20) BICYCLETTE (HOMME)
                 (30) BICYCLETTE, BLEU (HOMME)
                 (10)
                 (20)
                 (30)
                 (10)
                 (20)
                 (30)

F3=Exit      F4=Prompt    F6=Change    F7=Backward    F8=Forward    F11=Job Status
F12=Cancel   F21=Print
```

When you finish adding information, press **Enter**. The edit panel returns to Change mode, and the new information you added now appears in the listing.

To delete a foreign language item description

To delete a foreign language item description, type **4** in the **Opt** column next to the item number you want to delete.

After you type **4** next to all of the items you want to delete, press **Enter**. The system deletes those items and appears again without the deleted item(s).

```
AMBDJEFR                      Edit Item Foreign Languages                      CHANGE
Position to item . . . . . BATTERY
language . . . . . CZC

Type options; press Enter.
4=Delete

Opt  Item number      Language      Descriptions
4   BICYCLE          SPN          (10) BICICLETA
      MEN'S, BLUE          (20) BICICLETA (HOMBRE)
      (30) BICICLETA, AZUL (PARA HOMBRE)
      BICYCLE          GER          (10) FAHRRAD
      MEN'S, BLUE          (20) FAHRRAD (HERRENS)
      (30) FAHRRAD, BLAU (HERRENS)
      BICYCLE          FRN          (10) BICYCLETTE
      MEN'S, BLUE          (20) BICYCLETTE (HOMME)
      (30) BICYCLETTE, BLEU (HOMME)

F3=Exit      F6=Add      F7=Backward  F8=Forward  F11=Job Status
F12=Cancel   F21=Print
```

To end foreign language item descriptions

When you finish the maintenance, use **F3=Exit**. If you are on an edit panel, you return to the display panel. Use **F3=Exit** again to return to the Item Maintenance menu.

Option 7. Code Files (AMEM05)

Use this option to define information for codes you use with this application. Code files consist of a code and a code description for each record in the file. Code file maintenance allows you to name and describe the values your company uses for these codes. Think of code values as abbreviations your company uses for specific fields.

Before you begin code file maintenance, make sure you have all your entry information at hand. You might find following a pattern is useful for setting up some codes. For example, each Territory code might begin with a letter representing a region of the country, such as “S” for all territories in the “South”.

How you start code file maintenance

Menu	Option
Product Data Management Main Menu (AMEM00)	File Maintenance option
File Maintenance menu (AMEM05)	Code Files option
Code File Maintenance menu (AMEM59)	Options 1-9

Code file maintenance panels

The code file maintenance panels show you a list of codes or show you entry fields for adding new codes to the list. You have several ways to move through the list of codes.

Scrolling the code list

Your company may have more codes than can be shown on the panel at one time. In that case, a plus sign (+) appears at the bottom of the list. Use **F7=Backward**, **F8=Forward**, **roll keys**, or **page** keys to scroll through the list of codes.

```
AMVAJDFR                               Display Countries                               DISPLA
Y                                                                                               New mail waitin
g
Position to code . . . . . aA3
Subset by name . . . . . aaaaaaaaaaaaaaaaaaaaaA25

Code   Name
ARG   Argentina
AST   Austria
AUS   Australia
BRZ   Brazil
CAN   Canada
CZC   Czechoslovakia
DNM   Denmark
FRN   France
GBR   Great Britain
GER   Germany
GRC   Greece
ITY   Italy
JAM   Jamaica
JPN   Japan
+

F3=Exit      F6=Edit      F7=Backward  F8=Forward
F12=Cancel   F21=Print
```

When you use **F8=Forward**, the next country codes appear in the list.

```
AMVAJDFR                               Display Countries
DISPLAY
ail waiting                               New m
Position to code . . . . . aA3
Subset by name . . . . . aaaaaaaaaaaaaaaaaaaaaA25

Code   Name
MEX    Mexico
NTH    Netherlands
POL    Poland
PRT    Portugal
```

Position to field

You can also move through the list by typing the code you want to see in the **Position to** field at the top of the panel.

```
AMVAJDFR                               Display Countries                               DISPLAY
New mail waiting
Position to code . . . . . GER
Subset by name . . . . . aaaaaaaaaaaaaaaaaaaaaA25

Code   Name
ARG    Argentina
AST    Austria
AUS    Australia
BRZ    Brazil
CAN    Canada
CZC    Czechoslovakia
DNM    Denmark
FRN    France
GBR    Great Britain
GER    Germany
GRC    Greece
ITY    Italy
JAM    Jamaica
JPN    Japan
+

F3=Exit   F6=Edit   F7=Backward  F8=Forward
F12=Cancel F21=Print
```

When you type a code in the **Position to** field and press **Enter**, the system moves the list so that the code you typed is at the top of the list. If none of the codes match the one you typed, the list begins with the entry immediately following the code you want.

To return to the original list, blank out the value in the **Position to** field and press **Enter**.

Subset by field

If you want to limit the list of codes to only those with a certain description, you can type the string of letters or numbers you want to match in the **Subset by** field.

```
AMVAJDFR          Display Countries          DISPLA
Y
                                                    New mail waitin
g
Position to code . . . . . aA3
Subset by name . . . . . Austr

Code   Name
ARG    Argentina
AST    Austria
AUS    Australia
BRZ    Brazil
CAN    Canada
CZC    Czechoslovakia
DNM    Denmark
FRN    France
GBR    Great Britain
GER    Germany
GRC    Greece
ITY    Italy
JAM    Jamaica
JPN    Japan
+

F3=Exit   F6=Edit   F7=Backward  F8=Forward
F12=Cancel F21=Print
```

When you press **Enter**, only those codes that match the string you enter appear in the list.

```
AMVAJDFR          Display Countries          DISPLA
Y
                                                    New mail waitin
g
Position to code . . . . . aA3
Subset by name . . . . . Aus

Code   Name
AST    Austria
AUS    Australia
```

To return to the original list, blank out the value in the Subset by field and press **Enter**.

Types of code file maintenance panels

You use two types of panels when you maintain code files: the Display panel and the Edit panel. Both panels show the list of codes. Each entry in the list contains a code and a name or description for that code.

Display panel. This panel is your starting point for code file maintenance. It is the first panel that appears when you choose an option on the Code File Maintenance menu.

The Display panel is like an inquiry panel. You can see information, but you cannot change it. For example, in the following panel, you see a list of three-position country codes and the names of the countries.

```
AMVAJDFR                      Display Countries                      DISPLAY
                                                                    New mail waiting
Position to code . . . . . aA3
Subset by name . . . . . aaaaaaaaaaaaaaaaaaaaaA25

Code   Name
ARG   Argentina
AST   Austria
AUS   Australia
BRZ   Brazil
CAN   Canada
ITY   Italy
CZC   Czechoslovakia
DNM   Denmark
FRN   France
GBR   Great Britain
GER   Germany
GRC   Greece
JAM   Jamaica
JPN   Japan

F3=Exit      F6=Edit      F7=Backward  F8=Forward
F12=Cancel   F21=Print
```

Edit panel. This panel appears when you use **F6=Edit** on the Display panel. It contains the same list of codes and code descriptions as the Display panel. It also contains an **Opt** field. Enter the number in this field that corresponds to the action you want to take against an entry in the list. The action available in code file maintenance is **4=Delete**.

```

AMVAGEFR                               Edit Country Data                               CHANGE
Position to code . . . . . aA3                               New mail waiting

Type options; press Enter.
4=Delete

- - - - EEC information - - - -
Country   Statistical   Member
code      value %         state?

Opt  Code   Name
ARG  ARG    Argentina
AST  AST    Austria
AUS  AUS    Australia
BRZ  BRZ    Brazil
CAN  CAN    Canada
CZC  CZC    Czechoslovakia
DNM  DNM    Denmark
FRN  FRN    France
GBR  GBR    Great Britain
GER  GER    Germany
GRC  GRC    Greece

F3=Exit      F6=Add      F7=Backward  F8=Forward
F12=Cancel   F21=Print

```

The Edit panel has two modes, Change and Add. In Change mode, you can type over the code name or description with a new name or description. You cannot change the code itself.

Use **F6=Add** to switch from Change mode to Add mode so that you can enter new codes and descriptions.

```
AMVAGEFR                               Edit Country Data                               ADD
ng                                       New mail waiti

Type information; press Enter.

                                     - - - - EEC information - - - -
Code   Name                           Country   Statistical   Member
aA3    aaaaaaaaaaaaaaaaaaaaaaaaaaaaaa  aA3       nnn.nn       state?
aA3    aaaaaaaaaaaaaaaaaaaaaaaaaaaaaa  aA3       nnn.nn       A
aA3    aaaaaaaaaaaaaaaaaaaaaaaaaaaaaa  aA3       nnn.nn       A
aA3    aaaaaaaaaaaaaaaaaaaaaaaaaaaaaa  aA3       nnn.nn       A
aA3    aaaaaaaaaaaaaaaaaaaaaaaaaaaaaa  aA3       nnn.nn       A
aA3    aaaaaaaaaaaaaaaaaaaaaaaaaaaaaa  aA3       nnn.nn       A
aA3    aaaaaaaaaaaaaaaaaaaaaaaaaaaaaa  aA3       nnn.nn       A
aA3    aaaaaaaaaaaaaaaaaaaaaaaaaaaaaa  aA3       nnn.nn       A
aA3    aaaaaaaaaaaaaaaaaaaaaaaaaaaaaa  aA3       nnn.nn       A
aA3    aaaaaaaaaaaaaaaaaaaaaaaaaaaaaa  aA3       nnn.nn       A
aA3    aaaaaaaaaaaaaaaaaaaaaaaaaaaaaa  aA3       nnn.nn       A
aA3    aaaaaaaaaaaaaaaaaaaaaaaaaaaaaa  aA3       nnn.nn       A
+
F3=Exit   F6=Change   F7=Backward   F8=Forward
F12=Cancel F21=Print
```

Use **F6=Change** to switch back to Change mode. Or, use **F12=Cancel** to return to the Display panel.

Code file report

If you want a report showing all codes defined in a code file, use **F21=Print**. The List Detail report prints for that code file. For example, using **F21** on the Display Country or Edit Country Data panels causes the List Country Detail report (AMVADPFR) to print.

Code	Name	Country code	Statistical value %	Member state?
ARG	Argentina		.00	
AST	Austria		.00	
AUS	Australia		.00	
BRZ	Brazil		.00	
CAN	Canada		.00	
CZC	Czechoslovakia		.00	
DNM	Denmark		.00	
FRN	France		.00	
GBR	Great Britain		.00	
GER	Germany		.00	

Example: maintain code files

Code file maintenance works the same way regardless of the code you want to add, change, or delete. When you first begin code file maintenance, the Display and Edit panels do not contain any code information. Use the Edit panel in Add mode to enter the code values your company uses. These code values make up the lists you see on the Display panel and Edit panel in Change mode.

You may have a long list of code values for some codes and a short list for others, depending on the number of different values your company uses for each code. Once you have added code information, you can change code names and descriptions and delete codes in the list.

The rest of this section demonstrates code file maintenance using one example: the Country code. Remember that you use the same types of panels and take the same actions to maintain information for any code.

Note: If you want to cancel the changes you've made and back out, use either **F3=Exit** or **F12=Cancel** before you press **Enter**. Once you press **Enter**, the changes are committed to the system.

To see a list of codes

When you select an option on the Code File Maintenance menu, the Display panel appears. This display panel shows you the list of codes already defined.

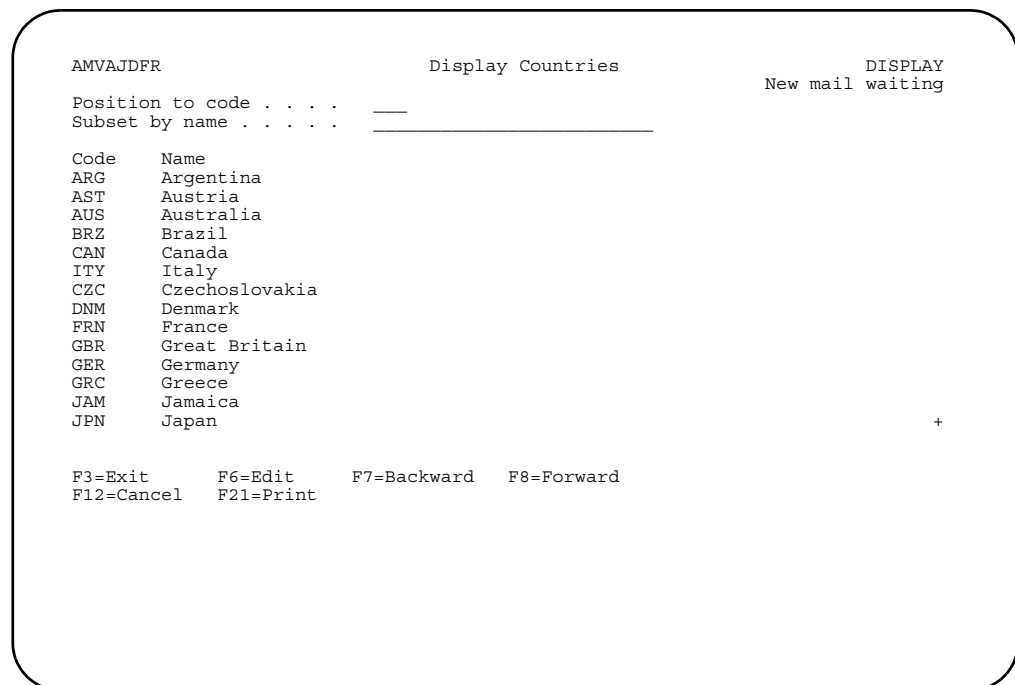

To change, delete, or add code information, use **F6=Edit**. The Edit panel appears in Change mode.

To return to the Code File Maintenance menu, use **F3=Exit**.

To change code information

The Edit panel in Change mode contains the same list of codes and code descriptions as the Display panel. To change the name or description for a code, type over the existing information and press **Enter**.

You cannot change the values in the **Code** column. To change a code value, you must first delete the existing code, using option **4=Delete**, then add a new code.

```

AMVAGEFR                      Edit Country Data                      CHANGE
                                                                    New mail waitin
g
Position to code . . . . . ____

Type options; press Enter.
4=Delete

Opt  Code  Name
ARG  ARG   Argentina
AST  AST   Austria
AUS  AUS   Australia
BRZ  BRZ   Brazil
CAN  CAN   Canada
CZC  CZC   Czechoslovakia
DNM  DNM   Denmark
FRN  FRN   France
GBR  GBR   Great Britain
GER  GER   Germany
GRC  GRC   Greece

F3=Exit  F6=Add  F7=Backward  F8=Forward
F12=Cancel  F21=Print

- - - - EEC information - - - -
Country  Statistical  Member
code     value %      state?

```

For example, if you need to change the name of code CZC from "Czechoslovakia" to "Czech Republic," you type the new name over the current name and press **Enter**.

```

AMVAGEFR                      Edit Country Data                      CHANGE
CHANGE                                                                    New mai
l waiting                                                                   
Position to code . . . . . ____

Type options; press Enter.
4=Delete

- - - - EEC information - -
Country  Statistical  M
code     value %      s
ember
Opt  Code  Name
state?
ARG  ARG   Argentina
AST  AST   Austria
AUS  AUS   Australia
BRZ  BRZ   Brazil
CAN  CAN   Canada
CZC  CZC   Czech Republic
DNM  DNM   Denmark
FRN  FRN   France

```

To add a new code, use **F6=Add**. The Edit Data (Change) panel changes to Edit Data (Add).

To add codes

Use the Edit panel in Add mode to enter new codes with their descriptions. Type the information for the codes you want to add. The **Code** field is required.

```

AMVAGEFR                      Edit Country Data                      ADD
                                New mail waiting

Type information; press Enter.

- - - - EEC information - -
ember Code Name Country Statistical M
tate? code value % s
      BEL Belgium

F3=Exit+ F6=Change F7=Backward F8=Forward
F12=Cancel F21=Print

```

When you finish adding code information, press **Enter**. The Edit panel returns to Change mode, and the codes you added now appear in the list.

```

AMVAGEFR                      Edit Country Data
CHANGE
                                New mail waiting
l waiting
Position to code . . . . ____

Type options; press Enter.
4=Delete

- - - - EEC information - -
ember Opt Code Name Country Statistical M
tate? code value % s
      ARG Argentina
      AST Austria
      AUS Australia
      BEL Belgium

```

To delete codes

Type **4** in the *Opt* column next to the codes you want to delete.

```

AMVAGEFR                               Edit Country Data                               CHANGE
g                                         New mail waitin
Position to code . . . . .
Type options; press Enter.
4=Delete

- - - - EEC information - - - -
Country   Statistical   Member
code     value %       state?

Opt  Code   Name
ARG   ARG    Argentina
AST   AST    Austria
AUS   AUS    Australia
4    BEL    Belgium
      BRZ    Brazil
      CAN    Canada
      CZC    Czech Republic
      DNM    Denmark
      FRN    France
      GER    Germany
      GRC    Greece
+

F3=Exit   F6=Add   F7=Backward   F8=Forward
F12=Cancel F21=Print

```

After you type **4** next to all of the codes you want to delete, press **Enter**. The system deletes those codes marked with 4. The list appears again without the deleted codes.

```

AMVAGEFR                               Edit Country Data                               CHAN
GE                                         New mail wait
ing
Position to code . . . . .
Type options; press Enter.
4=Delete

- - - - EEC information - - - -
Country   Statistical   Member
code     value %       state?

Opt  Code   Name
ARG   ARG    Argentina
AST   AST    Austria
AUS   AUS    Australia
      BRZ    Brazil
      CAN    Canada
      CZC    Czech Republic
      DNM    Denmark
      FRN    France
      GBR    Great Britain
      GER    Germany
      GRC    Greece

F3=Exit   F6=Add   F7=Backward   F8=Forward
F12=Cancel F21=Print

```

[Contents](#)

[Index](#)

To end code file maintenance

When you have finished maintaining codes, use **F3=Exit** to return to the Code File Maintenance menu. If you are on an Edit panel, you return to the Display panel. Use **F3=Exit** again to return to the menu.

Option 8. Offline Maintenance (AMEM05)

Use this option anytime you want to perform offline maintenance on any of the following master files:

- Item Master
- Product Structure
- Production Facility
- Routing

This option allows you to make additions, changes, and deletions. Offline maintenance includes either editing or editing and updating the file.

```
AMEM55                               Product Data Management          **
*****                               Offline Maintenance

Type option or command; press Enter.

1. Item Master
2. Product Structure
3. Production Facility
4. Routing
```

Option 1. Item Master. Use this option to do offline maintenance on the Item Master file.

Option 2. Product Structure. Use this option to do offline maintenance on the Product Structure file.

Option 3. Production Facility. Use this option to do offline maintenance on the Production Facility file.

Option 4. Routing. Use this option to do offline maintenance on the Routing and Routing Description files.

Note: The tasks in Options 1, 2, and 4 can also be executed in batch jobs outside this menu. See Appendix D, "Automated job submission for PDM" for more information on using the automated job submission function.

Option 1. Item Master (AMEM55)

Use this option anytime you want to perform offline file maintenance for the Item Master file.

Note: When EPDM is installed and the EPDM to PDM interface is activated, maintain the Item Master file from EPDM.

What information you need: See “Item Master (ITMDKT) file” for more details about what information is required for offline file maintenance.

What reports are printed:

- Item Master Offline Maintenance Edit List (AMKE1)
- Item Master Offline Load Audit List (AMKE3).

What forms you need:

- Item Master Offline Maintenance (A-Record) (PM-26A and PM-26B)
- Item Master Offline Maintenance (B-Record) (PM-27)
- Item Master Offline Maintenance (C-Record) (PM-28).

AMVPOF—Item Master Offline Maintenance Options

Use this display to select which action you wish to perform on the Item Master offline maintenance file. You can edit only or edit and update the file. In both instances an edit report of exceptions, error messages, and final record counts is printed. If you choose to update the file, a second report showing all transactions passed to the update program and final record counts is also printed.

This display appears when you select option 1 on the Offline Maintenance menu (AMEM55).

```
Date 8/20/**      Item Master Offline Maintenance Options      AMVPOF

Select one of the following . . . n 1. Edit only
                                   2. Edit and update

Offline file name . . . . . aaaaaaaA10
Offline file library name . . . . . aaaaaaaA10

Select option for update . . . . n 0. Retain all offline records
                                   1. Retain only error records
                                   2. Delete offline file

F3=Exit
```

What to do

Type in the information required and press **Enter**. Go to menu AMEM55.

Function keys

F3= Exit returns you to the Offline Maintenance menu (AMEM55).

Fields

Select one of the following. Type a number that indicates the type of maintenance you want to perform.

- 1 Edit only
- 2 Edit and update.

Offline file name. Type the name of the file which has the offline maintenance transactions.

Offline file library name. Type the library name in which the offline file resides.

[Contents](#)

[Index](#)

Select option for update. Type a number that indicates the type of update you want to perform.

- 0** Retain all offline records
- 1** Retain only error records
- 2** Delete offline file

Option 2. Product Structure (AMEM55)

Use this option anytime you want to perform offline file maintenance for the Product Structure file.

What information you need: See “Product Structure file (PSDSKT)” for more details about what information is required for offline file maintenance.

What reports are printed:

- Product Structure Offline Maintenance Edit List (AMEB0)
- Product Structure Offline Maintenance Audit List (AMEB1).

What forms you need: Product Structure Offline Maintenance (PM-15).

AMVPOF—Product Structure Offline Maintenance Options

Use this display to select which action you wish to perform on the Product Structure offline maintenance file. You can edit only or edit and update the file. In both instances an edit report of exceptions, error messages, and final record counts is printed. If you choose to update the file, a second report showing all transactions passed to the update program and final record counts is also printed.

This display appears when you select option 2 on the Offline Maintenance menu (AMEM55).

```
Date 8/20/**      Product Structure Offline Maintenance Options      AMVPOF

Select one of the following . . . n 1. Edit only
                                   2. Edit and update

Offline file name . . . . . aaaaaaaA10
Offline file library name . . . . . aaaaaaaA10

Select option for update . . . . . n 0. Retain all offline records
                                   2. Delete offline file

F3=Exit
```

What to do

Type in the information required and press **Enter**. Go to menu AMEM55.

Function keys

F3=Exit returns you to the Offline Maintenance menu (AMEM55).

Fields

See “AMVPOF—Item Master Offline Maintenance Options” for detailed information on the fields for this display.

Option 3. Production Facility (AMEM55)

Use this option anytime you want to perform offline file maintenance for the Production Facility file.

What information you need: See “Production Facility file (PFDSKT)” for more details about what information is required for offline file maintenance.

What reports are printed:

- Production Facility Offline Maintenance Edit List (AMVTE)
- Production Facility Offline Maintenance Audit List (AMVTL).

What forms you need: Production Facility Offline Maintenance (PM-30A and PM-30B).

AMVPOF—Production Facility Offline Maintenance Options

Use this display to select which action you wish to perform on the Routing offline maintenance file. You can edit only or edit and update the file. In both instances an edit report of exceptions, error messages, and final record counts is printed. If you choose to update the file, a second report showing all transactions passed to the update program and final record counts is also printed.

This display appears when you select option 3 on the Offline Maintenance menu (AMEM55).

```
Date 8/20/**      Production Facility Offline Maintenance Options  AMVPOF

Select one of the following . . . n 1. Edit only
                                   2. Edit and update

Offline file name . . . . . aaaaaaaA10
Offline file library name . . . . . aaaaaaaA10

Select option for update . . . . n 0. Retain all offline records
                                   1. Retain only error records
                                   2. Delete offline file

F3=Exit
```

What to do

Type in the information required and press **Enter**. Go to menu AMEM55.

Function keys

F3=Exit returns you to the Offline Maintenance menu (AMEM55).

Fields

See “AMVPOF—Item Master Offline Maintenance Options” for detailed information on the fields for this display.

Option 4. Routing (AMEM55)

Use this option anytime you want to perform offline file maintenance for the Routing file.

What information you need: See “Routing file (RTGDKT)” for more details about what information is required for offline file maintenance.

What reports are printed:

- Routing Offline Maintenance Edit List (AMEB3)
- Routing Offline Maintenance Audit List (AMEB4).

What forms you need: Routing File Offline Maintenance (PM-29).

AMVPOF—Routing Offline Maintenance Options

Use this display to select which action you wish to perform on the Routing offline maintenance file. You can edit only or edit and update the file. In both instances an edit report of exceptions, error messages, and final record counts is printed. If you choose to update the file, a second report showing all transactions passed to the update program and final record counts is also printed.

This display appears when you select option 4 on the Offline Maintenance menu (AMEM55).

```
Date 8/20/** Routing Offline Maintenance Options AMVPOF

Select one of the following . . . n 1. Edit only
                                   2. Edit and update

Offline file name . . . . . aaaaaaaA10
Offline file library name . . . . . aaaaaaaA10

Select option for update . . . . n 0. Retain all offline records
                                   2. Delete offline file

F3=Exit
```

What to do

Type in the information required and press **Enter**. Go to menu AMEM55.

Function keys

F3=Exit returns you to the Offline Maintenance menu (AMEM55).

Fields

See “AMVPOF—Item Master Offline Maintenance Options” for detailed information on the fields for this display.

Option 9. PDM Control File Maintenance (AMEM05)

Use this option to access the PDM Control file (PDMCTL) displays that allow you to set tailoring options that control how PDM handles certain functions. These options are in addition to those defined during Install/Tailor.

What information you need: None.

What reports are printed: PDM Control File Maintenance report (AMENCRO).

Select the options you want to use on the following displays. These options remain in effect until changed. You will find helpful discussion concerning these options in Chapter 2. You also should read Appendix C, "Information retrieval and calculations" for more information on the costing function.

AMDPDM1—Control File Maintenance

Use this display to define and maintain the summary cost titles and user cost element titles to be used in the presentation of associated information.

The shipped default titles are shown on this panel. You can reset them if you wish.

```
AMDPDM1                Product Data Management
                        Control File Maintenance

Select tailoring options, and press Enter.

Summary cost titles:
Summary cost 1 . . . . . Purchase
Summary cost 2 . . . . . Purchase O/H
Summary cost 3 . . . . . Labor
Summary cost 4 . . . . . Labor O/H

User cost element titles:
User cost 1. . . . . Other Cost 1
User cost 2. . . . . Other Cost 2
User cost 3. . . . . Other Cost 3
User cost 4. . . . . Other Cost 4

F1=Help      F5=Refresh      F8=Forward      F24=End
F10=Reset defaults
```

What to do

Type in the information you want to change and press **Enter**. The next page of Control File options appears so you can continue adding or maintaining information.

Function keys

F5=Refresh causes the panel to appear again in its original form.

F8=Forward causes the next page of information to appear.

F10=Reset defaults causes the fields to be reset with the text from NLSTXT.

F12=Cancel cancels any changes you made and causes the File Maintenance menu (AMEM05) to appear.

F24=End causes the File Maintenance menu (AMEM05) to appear and updates any changes you made.

Fields

Title. The shipped default appears. You can change it to another 13-character title.

AMDPDM2—Control File Maintenance

Use this display to assign cost elements to summary titles. The amounts in each of the cost elements will be summarized into one of the four summary cost titles for reporting on product costing reports. You can change the assignments if you wish.

```

AMDPDM2                                Product Data Management
                                         Control File Maintenance

Select tailoring options, and press Enter.

Summary cost titles:  *****
Summary cost number:  1          2          3          4

Cost element                Summary cost assignment
Material . . . . .          n
Outside operations . . . . . n
Purchase overhead . . . . . n
Setup labor . . . . .       n
Run labor . . . . .         n
Setup machine . . . . .     n
Run machine . . . . .       n
Manufacturing overhead . . . n
***** . . . . .           n
***** . . . . .           n
***** . . . . .           n
***** . . . . .           n

F1=Help      F5=Refresh  F7=Backward  F8=Forward
F10=Reset defaults  F12=Cancel  F24=End

```

What to do

Type in the information you want to change and press **Enter**.

Function keys

F5=Refresh causes the panel to appear again in its original form.

F7=Backward causes the previous page of information to appear.

F8=Forward causes the next page of information to appear.

F10=Reset defaults causes the fields to be reset with the text from NLSTXT.

F12=Cancel cancels any changes you made and causes the File Maintenance menu (AMEM05) to appear.

F24=End causes the File Maintenance menu (AMEM05) to appear and updates any changes you made.

Fields

Summary cost assignment. The shipped default appears. You can change it to another cost assignment. The user cost elements are shipped with 0 summary cost assignments.

AMDPDM3—Control File Maintenance

Use this display to assign a default site ID. The Default Site ID field is required only if EPDM is activated. See “How PDM works with other applications” for information on the impact of this field.

Enter a valid production site. The site entered will be used to migrate PDM’s data files to EPDM.

```
AMDPDM3                Product Data Management
                        Control File Maintenance

Select tailoring options, and press Enter.

Default site ID . . . . . aA3 *****

F1=Help  F7=Backward  F12=Cancel  F24=End
```

What to do

Type in the information you want to change and press **Enter**.

Function keys

F7=Backward causes the previous page of information to appear.

F12=Cancel cancels any changes you made and causes the File Maintenance menu (AMEM05) to appear.

F24=End causes the File Maintenance menu (AMEM05) to appear and updates any changes you made.

Fields

Default site ID. The default production site ID you want to use. The entry must be a valid EPDM Site Master record.

Chapter 7. Yield calculation

When you select option 5 on the Main Menu (AMEM00) the Yield Calculation menu (AMEM06) appears. This menu allows you to calculate cumulative yield for the routings of parent items and to calculate the adjusted quantity per for components of parent items that have been updated.

- Option 1. Calculate Cumulative Yield (AMEM06)..... 7-2
- Option 2. Calculate Adjusted Quantity Per (AMEM06)..... 7-3

This menu has no displays associated with it. Selecting either option performs the calculations and schedules for the associated report.

```

AMEM06                               Product Data Management          *****
                                Yield Calculation

Type option or command; press Enter.

    1. Calculate Cumulative Yield
    2. Calculate Adjusted Quantity Per

==> _____

F3=Exit      F4=Prompt    F9=Retrieve   F10=Actions
F11=Job status  F12=Return   F22=Messages
  
```

Option 1. Calculate Cumulative Yield. Use this option to calculate the cumulative yield for the routings of all parent items that have been maintained since the last time this option has been run and schedules a report to print showing the calculated cumulative yield.

Note: If you use option 1, you must also use option 2. If this option has never been selected, the job will run a long time because it will calculate yields for all items.

Option 2. Calculate Adjusted Quantity Per. Use this option to calculate the adjusted quantity per for the components of all parent items that have been maintained since the last time this option has been run and schedules a report to print showing the calculated adjusted quantity per.

Note: You should run the calculations on this menu whenever you have performed Routing or Product Structure File Maintenance.

Option 1. Calculate Cumulative Yield (AMEM06)

Use this option anytime you want to calculate cumulative yield for the routings of parent items that have been updated.

What information you need: None.

What report is printed: Calculate Cumulative Yield (AME78).

What forms you need: None.

When you select option 1 and press **Enter**, PDM calculates the cumulative yield and schedules the report for printing. The Yield Calculation menu (AMEM06) appears again.

[Contents](#)[Index](#)

Option 2. Calculate Adjusted Quantity Per (AMEM06)

Use this option anytime you want to calculate the adjusted quantity per for the components of any parent items that have been updated.

What information you need: None.

What report is printed: Calculate Adjusted Quantity Per (AME82).

What forms you need: None.

When you select option 2 and press **Enter**, PDM calculates the adjusted quantity per and schedules the report for printing. The Yield Calculation menu (AMEM06) appears again.

Chapter 8. Report descriptions

This chapter contains samples of some of the reports the PDM application produces. The reports are presented here by task, sorted in alphabetical order.

The reports pertaining to features and options, product costing, routings, or production facilities are not available unless you select those functions and files during application tailoring.

Table 8-1. (Page 1 of 2) List of reports, sorted by report name

Report	ID	See page
Calculate Adjusted Quantity Per	AME82	8-90
Calculate Cumulative Yield	AME78	8-87
Cost Variations—Current to Standard	AMEH8	8-61
End-Item Where-Used	AMEF75	8-25
Feature/Options Report	AMEF1	8-27
Indented Bill	AMEF72	8-30
Indented Cost Sheet—Current or Standard	AMEG72	8-64
Item Master File Maintenance	AMVT0	8-3
Item Master File Report—Brief	AMVE40	8-15
Item Master File Report—Complete	AMVE41	8-18
Item Master File Report—Current Costs Sequenced by Item	AMVE42	8-20
Item Master File Report—Purchase Item Description	AMVE44	8-24
Item Master File Report—Purchase Item Detail	AMVE43	8-22
Management Cost Summary—Current or Standard	AMEH7	8-67
Operations Cost Sheet—Current or Standard	AMEH41, AMEH42	8-69
Product Cost Simulation—Current and Standard Costs or Average Costs	AMEI31	8-75
Product Cost Update Report—Current or Standard Costs	AMEI30	8-73
Product Structure Transaction List	AMEU5	8-32
Production Facility Maintenance	AMVT7	8-39
Production Facility Report—Sequenced by Facility or Department	AMV43	8-44
Production Facility Where-Used	AMEG12	8-48
Routing and Single Level Retrieval with Blow-Through	AMEG4	8-52
Routing List	AMEG11	8-57
Routing Transaction List	AMEU9	8-59
Single Level Bill with Blow-Through	AMEF71	8-35
Single Level Cost Sheet—Current or Standard	AMEG71	8-35
Single Level Where-Used	AMEF74	8-37
Summarized Bill	AMEF73	8-38
Variable Capacity Master File Maintenance	AMVTC	8-51

Table 8-1. (Page 2 of 2) List of reports, sorted by report name

Report	ID	See page
Work-in-Process Cost Worksheet—Current, Standard, or Average Costs	AME86	8-82

Table 8-2. List of reports, sorted by report ID

ID	Report	See page
AME78	Calculate Cumulative Yield	8-87
AME82	Calculate Adjusted Quantity Per	8-90
AME86	Work-in-Process Cost Worksheet—Current, Standard, or Average Costs	8-82
AMV43	Production Facility Report—Sequenced by Facility or Department	8-44
AMEF1	Feature/Options Report	8-27
AMEF71	Single Level Bill with Blow-Through	8-35
AMEF72	Indented Bill	8-30
AMEF73	Summarized Bill	8-38
AMEF74	Single Level Where-Used	8-37
AMEF75	End-Item Where-Used	8-25
AMEG4	Routing and Single Level Retrieval with Blow-Through	8-52
AMEG11	Routing List	8-57
AMEG12	Production Facility Where-Used	8-48
AMEG71	Single Level Cost Sheet—Current or Standard	8-78
AMEG72	Indented Cost Sheet—Current or Standard	8-64
AMEH7	Management Cost Summary—Current or Standard	8-67
AMEH8	Cost Variations—Current to Standard	8-61
AMEH41, AMEH42	Operations Cost Sheet—Current or Standard	8-69
AMEI30	Product Cost Update Report—Current or Standard Costs	8-73
AMEI31	Product Cost Simulation—Current and Standard Costs or Average Costs	8-75
AMEU5	Product Structure Transaction List	8-32
AMEU9	Routing Transaction List	8-59
AMVE40	Item Master File Report—Brief	8-15
AMVE41	Item Master File Report—Complete	8-18
AMVE42	Item Master File Report—Current Costs Sequenced by Item	8-20
AMVE43	Item Master File Report—Purchase Item Detail	8-22
AMVE44	Item Master File Report—Purchase Item Description	8-24
AMVTC	Variable Capacity Master File Maintenance	8-51
AMVT0	Item Master File Maintenance	8-3
AMVT7	Production Facility Maintenance	8-39

Item Master File Maintenance (AMVT0)

NORTHCREEK IND.		ITEM MASTER FILE MAINTENANCE						DATE 7/01/		
**	TIME 15.29.34	PAGE	1	AMVT0					OPER	UPDATE#
GENERAL INFORMATION (CHANGED - OLD VALUE)										
ITEM NUMBER	AMTPF0218	DESCRIPTION	18	CU FT	AMAXZA TOP FREEZER	ALTERNATE ITEM NUMBER	AMTPF0219			
ITEM TYPE CODE	4	ENG DRW			QC CONTROL	ITEM PRICE CLASS				
ITEM CLASS	CI	STD BCH QTY	1.000		SHELF LIFE	SALES TAX IND	T00			
VALUE CLASS	S-NUMBER FLAG				BATCH/					
LOT CTL	0	COMMISSION PCT	.000							
INVENTORY CODE	01	LOW LEVEL		2	INSP ON RECEIPT	0	PRICE U/			
M	UNIT VOLUME									
DEPARTMENT	REP3	STD TOT CUM YLD	1.000	DISCRETE ALLOC	0	VOLUME U/				
M										
ITM ACTG CLS	AA1	CUR TOT CUM YLD	1.000	WARRANTY PER		UNIT WEIGHT	.000	TAX COMM	C	
ODE										
CARRYING RATE	.000	AVG TOT CUM YLD	1.000	WARRANTY PER U/M	EA	WEIGHT U/M		EA	TAX WGHT/	
UNIT										
COUNTRY OF ORIG	USA	SINGLE LEVEL COMP'S		SERIAL NUM REQD	0	SPEC GRAVITY	.0000	ORDER U/		
M CLASS	EA									
W/										
H STK LOC	DIRECT USAGES	1	PRT ON	SALES ANL	0	PACKING CODE	ITEM SALES GROUP			
ABC										
STOCKING U/M	EA	ROUTING OPERATIONS		KIT DOC PRINT OPT	0	BILL/LAD COM CD	AZP			
STD SETUP COST/										
LOT	.00000000			SUPP WGHT	RECORD MAINTENANCE:					
M	UNIT COST DEFAULT	314.00000000	VENDR PRIMARY	SUPP WGHT U/						
EA	CREATED	SCASEY	07/01/**							
BASE PRICE		.000	PUR TAX IND	TAX CLASS	CHANGED D					
HARRIS	07/20/**									
BASE PRICE EFFECTIVE DATE		6/30/**								
GENERAL INFORMATION (CHANGED - NEW VALUE)										
ITEM NUMBER	AMTPF0218	DESCRIPTION	18	CU FT	AMAXZA TOP FREEZER	ALTERNATE ITEM NUMBER	AMTPF0219			
ITEM TYPE CODE	4	ENG DRW			QC CONTROL	ITEM PRICE CLASS				
ITEM CLASS	CI	STD BCH QTY	1.000		SHELF LIFE	SALES TAX IND	T00			
VALUE CLASS	S-NUMBER FLAG				BATCH/					
LOT CTL	0	COMMISSION PCT	.000							
INVENTORY CODE	01	LOW LEVEL		2	INSP ON RECEIPT	0	PRICE U/			
M	UNIT VOLUME									
DEPARTMENT	REP3	STD TOT CUM YLD	1.000	DISCRETE ALLOC	0	VOLUME U/				
M										
ITM ACTG CLS	AA3	CUR TOT CUM YLD	1.000	WARRANTY PER	36	UNIT WEIGHT	300.000	TAX COMM	C	
ODE										
CARRYING RATE	.000	AVG TOT CUM YLD	1.000	WARRANTY PER U/M	MO	WEIGHT U/M		LB	TAX WGHT/	
UNIT										
COUNTRY OF ORIG	USA	SINGLE LEVEL COMP'S		SERIAL NUM REQD	0	SPEC GRAVITY	.0000	ORDER U/		
M CLASS	EA									
W/										
H STK LOC	DIRECT USAGES	1	PRT ON	SALES ANL	0	PACKING CODE	ITEM SALES GROUP			
DEF										
STOCKING U/M	EA	ROUTING OPERATIONS		KIT DOC PRINT OPT	0	BILL/LAD COM CD	BILLCOMM			
STD SETUP COST/										
LOT	.00000000			SUPP WGHT	RECORD MAINTENANCE:					
M	UNIT COST DEFAULT	314.00000000	VENDR PRIMARY	SUPP WGHT U/						
EA	CREATED	SCASEY	07/01/**							
BASE PRICE		.000	PUR TAX IND	TAX CLASS	CHANGED D					
HARRIS	07/20/**									
BASE PRICE EFFECTIVE DATE		6/30/**								

NORTHCREEK IND.		ITEM MASTER FILE MAINTENANCE			DATE 7/01/	
** TIME	15.29.34	PAGE	2	AMVT0	OPER	UPDATE#
COSTING INFORMATION (CHANGED - OLD VALUE)						
ITEM NUMBER	AMTPF0218	RECAST	FLAG	B	RECAST NEEDED	
CUR UNIT COST		\$312.50000000			CUR COST STATUS CD	CUM F/O COST ROLL FACT .0000
STD UNIT COST		\$314.00000000			STD COST STATUS CD	LABOR HOURS .0000
CUR SETUP COST/LOT		\$.00000000			CST TECHNIQUE CODE	STD LOT SIZE .000
-----CURRENT-----	LAST MAINT		TBL	-----THIS LEVEL-----		-----LOWER LEVELS-----
MATERIAL	5/27/**			\$312.56247182		\$.00000000
OUTSIDE OPERATIONS						
PURCHASE OVERHEAD				\$.00000000		\$.00000000
SETUP LABOR	8/28/**			\$.00000000		\$.00000000
RUN LABOR				\$.00000000		\$.00000000
SETUP MACHINE						
RUN MACHINE						
MFG OVERHEAD						
MISC COST 1						
MISC COST 2						
MISC COST 3						
MISC COST 4						
-----STANDARD-----	LAST MAINT		TBL	-----THIS LEVEL-----		-----LOWER LEVELS-----
MATERIAL	5/27/**			\$314.00000000		
OUTSIDE OPERATIONS						
PURCHASE OVERHEAD				\$.00000000		
SETUP LABOR	8/28/**			\$.00000000		
RUN LABOR				\$.00000000		
SETUP MACHINE						
RUN MACHINE						
MFG OVERHEAD						
MISC COST 1						
MISC COST 2						
MISC COST 3						
MISC COST 4						
COSTING INFORMATION (CHANGED - NEW VALUE)						
ITEM NUMBER	AMTPF0218	RECAST	FLAG	B	RECAST	
CUR UNIT COST		\$312.50000000			CUR COST STATUS CD	CUM F/O COST ROLL FACT .0000
STD UNIT COST		\$314.00000000			STD COST STATUS CD	LABOR HOURS 50.0000
CUR SETUP COST/LOT		\$.00000000			CST TECHNIQUE CODE	STD LOT SIZE 25.000
-----CURRENT-----	LAST MAINT		TBL	-----THIS LEVEL---		-----LOWER LEVELS-----
MATERIAL	5/27/**			\$312.5624		
OUTSIDE OPERATIONS						
PURCHASE OVERHEAD				\$.0000		
SETUP LABOR	8/28/**			\$.0000		
RUN LABOR				\$.0000		
SETUP MACHINE						
RUN MACHINE						
MFG OVERHEAD						
MISC COST 1						
MISC COST 2						
MISC COST 3						
MISC COST 4						
-----STANDARD-----	LAST MAINT		TBL	-----THIS LEVEL---		-----LOWER LEVELS-----
MATERIAL	5/27/**			\$314.0000		
OUTSIDE OPERATIONS						
PURCHASE OVERHEAD				\$.0000		
SETUP LABOR	8/28/**			\$.0000		
RUN LABOR				\$.0000		
SETUP MACHINE						
RUN MACHINE						
MFG OVERHEAD						
MISC COST 1						
MISC COST 2						
MISC COST 3						
MISC COST 4						

NORTHCREEK IND.		ITEM MASTER FILE MAINTENANCE			DATE	7/01/
**	TIME 15.29.34	PAGE	2	AMVT0		
					OPER	UPDATE#
PURCHASING INFORMATION (CHANGED - OLD VALUE)						
ITEM NUMBER	AMTPF0218	BUYER NUMBER		ACCOUNT	PURCHASE PRICE	
EXTENDED DESCRIPTION-						
-WEIGHTED PERCENT-						
LEAD TIME %		-TOLERANCE PERCENT-		RECEIPT REQUIRED	1	AVG ORDER SIZE
DELIVERY %		REC PLUS %		ALLOW DAYS EARLY		PURCH COMMODITY
QUALITY %		REC MINUS %		SHIP VIA		PRE-APPROVED
PRICE %				ALPHA FACTOR	.000	APPLC
EARLY DELIVERY %						0
LATE DELIVERY %						
OVERSHIP %						
UNDERSHIP %						
PURCHASING INFORMATION (CHANGED - NEW VALUE)						
ITEM NUMBER	AMTPF0218	BUYER NUMBER	NW331	ACCOUNT	842850	PURCHASE PRICE
EXTENDED DESCRIPTION-						
-WEIGHTED PERCENT-						
LEAD TIME %		-TOLERANCE PERCENT-		RECEIPT REQUIRED	1	AVG ORDER SIZE
DELIVERY %		REC PLUS %		ALLOW DAYS EARLY		PURCH COMMODITY
QUALITY %		REC MINUS %		SHIP VIA		PRE-APPROVED
PRICE %				ALPHA FACTOR	.000	APPLC
EARLY DELIVERY %						0
LATE DELIVERY %						
OVERSHIP %						
UNDERSHIP %						

NORTHCREEK IND.		ITEM MASTER FILE MAINTENANCE CONTROL SHEET			DATE	7/01/
**	TIME 15.29.34	PAGE	3	AMVT0		
					OPER	UPDATE#
----- TRANSACTION UPDATE STATISTICS -----						
	ITEMS		ITEMS		ITEMS	
	ADDED		CHANGED		DELETED	
	0		1		0	

These reports print only if, during application tailoring, you selected to print before and after images of master files that have changed. The Item Master File Maintenance report and the Item Master File Maintenance Control Sheet print each time you use **F24** to end an Item Master file maintenance session. The control sheet provides the number of items added, changed, and deleted. If IFM is installed, the **ACCOUNT** field is replaced with a **NATURE** field.

Note: The titles of the cost elements shown in costing information on this report depend on the titles that were selected in the PDM Control file.

Fields

ITEM NUMBER. The unique alphanumeric identification of this item.

DESCRIPTION. The description or name of this item that appears on inquiries and reports.

ALTERNATE ITEM NUMBER. A user-defined alternate identifier number used for this item, such as the OEM or UPC number. This is used by Electronic Commerce (EC).

ITEM TYPE CODE. Code that best describes the type of item:

0	Phantom
1	Assembly or subassembly
2	Fabricated item
3	Raw material
4	Purchased item
9	User option (Special)
F	Feature
K	Kit

Note: Item type code 9 (user option) may have purchase, purchase overhead (calculated), labor, labor overhead, and components. If you selected item type code 9, labor and labor overhead (this-level) are calculated from the routing (cost technique code = R) or from the Labor/Overhead Table (cost technique code = T). Or, if the cost technique code was blank, the manually-entered purchase, labor, and labor overhead costs are used. PDM does not roll up lower-level costs when the item type is 9, and you must always manually enter purchase cost. Purchase overhead is calculated based on the Purchase Overhead Table code and user-entered purchase content. The lower-level cost fields of an item type 9 are forced to zero, even if the item has components.

ENG DRW (Engineering Drawing Number). A number used to identify a drawing of an item.

QC CONTROL. A number that indicates if this item requires quality control inspection.

- | | |
|---|---|
| 1 | The item requires quality control inspection. The SHELF LIFE field cannot be zero and the BATCH/LOT CTL field must be 1. |
| 0 | The item does not require quality control inspection. The SHELF LIFE field must be zero and the BATCH/LOT CTL field can be either 1 or 0. |

ITEM PRICE CLASS. A code defined by your company to group or classify items for pricing purposes.

ITEM CLASS. A code that identifies the item class for this item according to how you classified your items into groups. FCST (if installed and interfacing) can use this field to classify items that have been coded as master level items (MLI code M or S).

STD BCH QTY (Standard Batch Quantity). The quantity that makes up a batch of this parent item. The quantity of each component in the parent item's product structure expresses the quantity required to make a standard batch quantity of the parent item. This quantity can be based on a capacity constraint (such as vessel size), an expected yield, or a production goal. It can also serve as a multiplier to improve the level of precision required for components which are used in very small quantities compared to one unit of the end item. If a quantity greater than 1 is entered, the component usage quantities are relative to this number. MPSP (if installed and interfacing) can use this field to calculate the quantities for resource profiles. The default is 1.

SHELF LIFE. If shelf life is required, this field shows the number of days (1-9999) that represents the shelf life for this item. At the end of the number of days shown, this item needs to be inspected again. If the **QC CONTROL** field is 0, the **SHELF LIFE** field must be 0.

SALES TAX IND (Sales Tax Indicator). The user-defined code used to classify the item for taxing during Customer Order Management and Accounts Receivable activity.

PROD FAM PLANNER (Production Family Planner). The number (user-assigned) that identifies the person responsible for planning the replenishment strategy for these production families.

VALUE CLASS. A code defined by your company that identifies the importance of the item. FCST (if installed and interfacing) can use this field to classify items that have been coded as master level items (MLI code M or S).

S-NUMBER FLAG. A code that indicates if the item has features. The available codes are:

- R** This item is an end-item with features; at least one of the features is required.
- N** This item is an end-item with features; no features are required.

BATCH/LOT CTL (Batch/Lot Control). A code that indicates whether this item requires batch/lot control. The valid codes are:

- 1** The item requires batch or lot control.
- 0** The item does not require batch or lot control.

COMMISSION PCT (Commission Percent). The percent of commission a sales representative can make on this item.

INVENTORY CODE. A code that classifies this item in inventory:

- 1** Inventory item
- 2** Miscellaneous item
- 3** Service item
- 4** Unstocked item.

LOW LEVEL. The lowest level in any product structure in which this item is directly used.

INSP ON RECEIPT (Inspect on Receipt). A code that indicates if this item needs to be inspected before it is received to stock.

- 1** The item requires inspection
- 0** The item does not require inspection

PRICE U/M (Price Unit of Measure). The unit of measure currently in effect for this item as defined in the Item Base Price file.

RESOURCE NUMBER. The unique number used by MPSP (if installed and interfacing) to identify this item as a critical resource.

Note: You must enter the Resource Number in the MPSP Resource Master file before you can enter it into the Item Master file.

DEPARTMENT. The number of the department responsible for this item. This field is informational only.

STD TOT CUM YLD (Standard Total Cumulative Yield). The standard operation yield for this item processed through all of its routing operations. Calculated from the standard operation yield, this percentage represents the amount (or size) of the parent item expected to be available at the end of the production process.

DISCRETE ALLOC (Discrete Allocation). A code that indicates if this item is allowed to have allocations.

- 1** The item can be allocated to manufacturing or customer orders.
0 The item cannot be allocated to manufacturing or customer orders.

RESOURCE BUILD FLAG. A code used by MPSP (if installed and interfacing) indicating which items or production families can have resource profiles generated. The available codes are listed below.

- Y** Build profile
N Do not build profile.

ITM ACTG CLS (Item Accounting Class). Class, defined by your company, to group or classify items for accounting purposes.

CUR TOT CUM YLD (Current Total Cumulative Yield). The production department's estimate of the current total operation yield for this item processed through all of its routing operations. Calculated from the current operation yield, this percentage represents today's or the near-term future amount of the parent item expected to be available at the end of the production process.

WARRANTY PER (Warranty Period). The length of warranty for this item, for example, a period of time, a quantity of units produced by a machine, a quantity of copies printed by a copier, and so forth.

UNIT WEIGHT. The weight of each item unit.

TAX COMM CODE (Tax Commodity Code). A code defined by your company that defines this item for tax purposes.

CARRYING RATE. The cost of carrying this item in inventory. This cost is used in computing the economic order quantity for this item.

AVG TOT CUM YLD (Average Total Cumulative Yield). The historical average based on past operation yield performance for this item processed through all of its routing operations. Calculated from the average yield, this percentage represents an historical average of the amount of the parent item expected to be available at the end of the production process. This average is based on past actual performance and is consistent with the averaging of actual hours reporting in Production Control and Costing (PC&C), if it is installed and interfacing with PDM.

WARRANTY PER U/M (Warranty Period Unit of Measure). The unit of measure for the warranty for this item.

WEIGHT U/M (Weight Unit of Measure). The unit of measure for the weight of this item.

TAX WGHT/UNIT (Tax Weight per Unit). The weight of one unit for tax purposes. This field is defined by your company.

COUNTRY OF ORIG (Country of Origin). A code defined by your company that indicates where the item is manufactured.

SINGLE LEVEL COMP'S. The number of components in this item's single level product structure.

SERIAL NUM REQD (Serial Number Required). A code that indicates whether or not the item is tracked by serial number. This field is used by the Customer Order Management (COM) application.

1 The item is tracked by serial number.

0 The item is not tracked by serial number.

SPEC GRAVITY (Specific Gravity). A ratio of the density of a material to the density of water. (Water = 1gm/ml.)

ORDER U/M CLASS. A code defined by your company used to group or classify items with functionally equivalent units of measure.

W/H STK LOC (Warehouse Stocking Location). A code defined by your company that indicates the location of the item in the warehouse.

DIRECT USAGES. The number of parent items for which this item is used as a component.

PRT ON SALES ANL (Print on Sales Analysis). A code indicating whether information about this item prints on the Sales Analysis report. A code of 1 indicates that information prints on the report, and a code of 0 indicates that it does not.

PACKING CODE. A code defined by your company that indicates how the item should be packed for shipment.

ITEM SALES GROUP . The user-defined sales group that includes this item.

STOCKING U/M (Stocking Unit of Measure). The unit used to express on-hand quantity and issue quantity

ROUTING OPERATIONS. The number of operations contained in the routing for this item.

KIT DOC PRINT OPT (Kit External Document Print Option). A code that indicates if an external document is printed for the components of a kit. An external kit document for the parent is always printed.

1 An external document for the kit components is printed.

0 No external document for the kit components is printed.

BILL/LAD COM CD (Bill of Lading Commodity Code). A code defined by your company that groups or classifies items for a bill of lading. Different types of products can be grouped by commodity code.

STD SETUP COST/LOT (Standard Setup Cost per Lot). The total standard cost of setting up a production run for this item per lot. This field is used by the economic order quantity calculation in IM, and the lot-sizing formulas in MRP and MPSP (if installed and interfacing).

SUPP WGHT (Supplemental Weight). A supplementary weight for the item when the tax weight is given in another unit of measure. For instance if the tax weight is given in kilos, the supplementary weight could be in pounds.

RECORD MAINTENANCE.

CREATED: The user ID of the person who created this item record and the date on which the record was created.

CHANGED: The user ID of the person who last maintained this record and the date on which the maintenance was performed.

UNIT COST DEFAULT. The numeric value that shows the cost to your company for one unit of the item. IM, and COM can use this field only if the cost field (standard, average, or last) is blank in the Item Balance file. FCST (if installed and interfacing) can use this field to cost forecast/projection quantities.

VENDOR PRIMARY. The number of the primary supplier of the item.

SUPP WGHT U/M (Supplemental Weight Unit of Measure). The unit of measure for the supplemental weight.

BASE PRICE. The unit price currently in effect for the item as defined in the Item Base Price file (used by IM analysis reports and by COM, if it is installed and interfacing with IM).

PUR TAX IND (Purchase Tax Indicator). The classification of this item for taxing during Purchasing and Accounts Payable activity.

TAX CLASS (Item tax class). The tax classification of an item; for example, special charge, surcharge, or IFM charge. (Any goods or services.)

BASE PRICE EFFECTIVE DATE . The date that the base price is effective. This field is used by the Customer Order Management (COM) application.

RECAST FLAG. The code used to identify the manufacturing costs (current, standard, or both) that need costing for this item. The available codes are:

blank The item does not need costing.
C The item needs current costing.
S The item needs standard costing.
B The item needs current and standard costing.
N This is a new item and needs current and standard costing.
O This is a new item and needs current costing.
P This is a new item and needs standard costing.

RECAST NEEDED

NO RECAST NEEDED. Depending on the Recost Flag code, this field indicates whether the unit cost for the item needs to be recosted.

CUR UNIT COST (Current Unit Cost). The sum of this item's current purchase, labor, and overhead content for both this-level and lower-level costs. The item's purchase content includes the outside operations cost.

CUR COST STATUS CD (Current Cost Status Code). The code used to identify the status of this item's current costs after product costing. If the item has more than one condition, the highest priority code is shown. In order of priority, D is the highest, followed by T and L. The available codes are:

blank All costs are complete.
D The item's product structure, routing, or both are inconsistent with it
T Some of the item's this-level costs are inconsistent with its item type.
L Some of the item's lower-level costs are inconsistent with its item type.

CUM F/O COST ROLL FACT (Cumulative Feature/Option Cost Roll Factor). The total cost percentage of all the options for a feature. This field does not exceed 1.000 (100%).

STD UNIT COST (Standard Unit Cost). The sum of this item's standard purchase, labor, and overhead content for both this-level and lower-level costs. The item's purchase content includes the outside operations cost.

STD COST STATUS CD (Standard Cost Status Code). The code used to identify the status of this item's standard costs after product costing. If the item has more than one condition, the highest priority code is shown. In order of priority, D is the highest, followed by T and L. The available codes are the same as for the **CUR UNIT COST** field.

LABOR HOURS. The number of labor hours per standard batch quantity for this item. This number is multiplied by the Labor/Overhead Table rates in calculating the labor or labor overhead cost for this-level per unit for this item. This field is used only when the Cost Technique code equals T.

CUR SETUP COST/LOT (Current Setup Cost Per Lot). The total current cost per lot for setting up a production run for this item. This field is used by MPSP (if installed and interfacing).

Note: If the cost technique code for this item is R, the current setup cost per lot was calculated by the system. For the other cost technique codes, the cost was entered through Item Master file maintenance.

CST TECHNIQUE CODE (Cost Technique Code). The code used to identify the PDM labor costing technique selected for this item. The available codes are:

- blank** The this-level labor and labor overhead values are not to be calculated by PDM product costing. The labor and labor overhead costs that you entered during Item Master file maintenance are shown.
- R** The this-level labor and labor overhead costs for the item are calculated using the routing hours and the facility rates. Cost Technique code R is not valid for item types 3 or 4.
- T** The this-level labor and labor overhead costs for the item are calculated using the labor hours you entered during Item Master file maintenance and the values in the Labor/Overhead Table.

STD LOT SIZE (Standard Lot Size). The standard lot size of the item that is normally ordered. This quantity is used to apportion the setup cost per unit for the item. This field may not be 0 (zero) if the item's Cost Technique code equals R. MRP (if installed and interfacing) can use this field to determine a quantity-based lead time. MPSP can use this field to calculate resource profiles.

TBL (Overhead Table Code)
CURRENT
STANDARD.

PURCHASE OVERHEAD: The code assigned to this item that references the entry in the Purchase Overhead Table containing the percent to be applied to the purchase amount used to calculate the unit purchase overhead cost (current or standard) this-level for this item. This code can be applied only to items that have item type codes 3, 4, or 9. This code has no relation to the cost technique code.

LABOR CONTENT: The code assigned to this item that references the entry in the Labor/Overhead Table containing the rate to be applied to the labor hours to calculate the unit labor cost (current or standard) this-level for this item. This code is required only if the cost technique code is T.

LABOR OVERHEAD: The code assigned to this item that references the entry in the Labor/Overhead Table containing the rate/percent to be applied to the labor hours to calculate the current unit overhead cost (current or standard) this-level for this item. This code is required only if the cost technique code is T.

**THIS LEVEL
CURRENT
STANDARD.**

PURCHASE CONTENT: The cost (current or standard) per unit for purchased parts, raw material, and outside operations for this item at this-level.

PURCHASE OVERHEAD: The overhead cost (current or standard) per unit for purchased parts or raw material at this-level.

LABOR CONTENT: The direct cost (current or standard) per unit that is made up of run labor plus setup labor for this item at this-level.

LABOR OVERHEAD: The indirect cost (current or standard) that is made up of run and setup machine costs, plus a portion of labor or machine cost for this item at this-level.

**LOWER LEVELS
CURRENT
STANDARD.**

PURCHASE CONTENT: The cost (current or standard) per unit for purchased parts, raw material, and outside operations for this item at this-level.

PURCHASE OVERHEAD: The overhead cost (current or standard) per unit for purchased parts or raw material at this-level.

LABOR CONTENT: The direct cost (current or standard) per unit that is made up of run labor plus setup labor for this item at this-level.

LABOR OVERHEAD: The indirect cost (current or standard) that is made up of run and setup machine costs, plus a portion of labor or machine cost for this item at this-level.

BUYER NUMBER. The number of the buyer for this item.

ACCOUNT. The number of the account associated with this item.

NATURE. An account or revenue/expense code.

PURCHASE PRICE. The purchase price for this item.

EXTENDED DESCRIPTION. An extension of the item's description in the A-record. This field is used by Purchasing, if installed and interfacing.

WEIGHTED PERCENT.

LEAD TIME%: The percentage to be placed on variances between quoted and actual vendor lead times.

DELIVERY%: The percentage to be placed on variances between ordered and delivered quantities.

QUALITY%: The percentage to be placed on reject quantities.

PRICE%: The percentage to be placed on variances between quoted and actual vendor prices.

EARLY DELIVERY%: The percentage to be placed on early delivery.

LATE DELIVERY%: The percentage to be placed on late delivery.

OVERSHIP%: The percentage to be placed on overshipment.

UNDERSHIP%: The percentage to be placed on undershipment.

TOLERANCE PERCENT.

PLUS%: The percentage of receipts defined by your company that can be overdelivered.

MINUS%: The percentage of receipts defined by your company that can be underdelivered.

RECEIPT REQUIRED. A code that indicates whether an inventory transaction (receipt) must be recorded before invoicing can be processed.

- 1 Receipt required
- 0 Receipt not required.

AVG ORDER SIZE. The average quantity ordered for this item.

ALLOW DAYS EARLY. The number of days that are acceptable for early delivery.

PURCH COMMODITY . A code defined by your company that identifies the commodity classification for this item.

SHIP VIA. A code identifying the means by which this item is normally shipped.

PRE-APPROVED. A code to indicate if this is a pre-approved item. This code is used only if purchase orders are being approved.

- 0 No. This is a normal item. This is the default.
- 1 Yes. This is a pre-approved item. Either no approval or only memo approval is required for this item, depending on the code in the Memo Approve Pre-approved Items field in the Purchasing Control file.

ALPHA FACTOR. The value in this field is used in calculating the vendor and buyer weighted performance percentages.

Item Master File Report—Brief (AMVE40)

```

NORTHCREEK IND          ITEM MASTER FILE REPORT-BRIEF          DATE 08/07/
** TIME 13.57.36 PAGE 1 AMVE40
                        SEQUENCED BY ITEM          OPER  TOUSET
                        ITEMS FROM SKT107          TO SKT109
                        INV  STK PRI I  ITEM          VAL          WHSE  COST ENGI
NEERING
ITEM NUMBER  DESCRIPTION          CODE U/M U/
M T IAC CLASS VENDOR DEPT  CLS  WEIGHT  STLC  TECH DRAWING NO
SKT107      FAB ITEM          01  EA  EA  2  SKT          .000          P104  R
SKT108      FAB ITEM2          01  EA  EA  2          .000          R
SKT109      FAB ITEM3          01  EA  EA  2          .000          R
    
```

```

NORTHCREEK IND          ITEM MASTER FILE REPORT-BRIEF          DATE 08/07/
** TIME 13.57.36 PAGE 2 AMVE40
                        SEQUENCED BY ITEM          OPER  TOUSET
                        ITEMS FROM SKT107          TO SKT109
                        3 ITEMS LISTED
    
```

To print this report, use option 1 on the File Listings menu.

The header indicates the sequence you selected. The sequence can be by

- Item
- Vendor
- Item type
- Item class
- Buyer
- Item accounting class

You can also print this report in one of these formats:

- Brief
- Complete
- Current costs only
- Standard costs only
- Purchase item detail
- Purchase item description

Note: To print the Item Master File Report in the current cost or standard cost format, you must have the security level necessary for handling Item Master cost information.

The format you choose determines the content and length of the report:

- If you specify Brief or Purchase item detail, the report contains one line of information per item.
- If you specify Complete or Purchase item description, the report contains multiple lines of detail per item.
- If you specify Current costs only, the report contains two lines of current cost information per item.
- If you specify Standard costs only, the report contains two lines of standard cost information per item.

Fields

ITEMS FROM/TO. The beginning and ending numbers identifying the range of items you selected for this report.

ITEM NUMBER. The unique alphanumeric identification of this item.

DESCRIPTION. The description or name of this item that appears on inquiries and reports.

INV CODE (Inventory Code). This field shows one of the following codes, which classify this item in inventory:

- 1 Inventory item
- 2 Miscellaneous item
- 3 Service item
- 4 Unstocked item.

STK U/M (Stocking Unit of Measure). The unit used to express on-hand quantity and issue quantity

PRI U/M (Price Unit of Measure). The unit of measure you use to price the item to customers. For example, if a box of bolts is sold by the box, but priced by the individual bolt, the pricing unit of measure is EA for each.

IT (Item Type Code). Code that best describes the type of item:

- 0 Phantom
- 1 Assembly or subassembly
- 2 Fabricated item
- 3 Raw material
- 4 Purchased item
- 9 User option
- F Feature
- K Kit

IAC (Item Accounting Class). Class, defined by your company, to group or classify items for accounting purposes.

ITEM CLASS. A code that identifies the item class for this item according to how you classified your items into groups. FCST (if installed and interfacing) can use this field to classify items that have been coded as master level items (MLI code M or S).

VENDOR. The number of the primary supplier of the item.

DEPT (Department Number). The number of the department responsible for this item. This field is informational only.

VAL CLS (Value Class). A user-assigned code that identifies the importance of the item. For example, the classes may be "A, B, C." FCST (if installed and interfacing) can use this field to classify items that have been coded as master level items (MLI code M or S).

WEIGHT. The weight of each item unit.

WHSE STLC (Warehouse Stock Location). A code that shows the item's location in the warehouse.

COST TECH (Cost Technique Code). This code identifies the costing technique selected for this item.

blank Uses values entered in during Item Master maintenance

R Routing hours and facility rates

T Costing Labor/Overhead Table rates and percentages

ENGINEERING DRAWING NO. A number used to identify a drawing of an item.

Item Master File Report—Complete (AMVE41)

```

NORTHCREEK IND.          ITEM MASTER FILE REPORT-COMPLETE          DATE 8/06/
** TIME 15.38.51 PAGE    1 AMVE41
                                SEQUENCED BY ITEM
                                ITEMS FROM 'BEGINNING' TO 'END'
                                VENDORS FROM 'BEGINNING' TO 'END'
                                ITEM TYPES FROM 'BEGINNING' TO 'END'
                                ITEM CLASSES FROM 'BEGINNING' TO 'END'
                                BUYERS FROM 'BEGINNING' TO 'END'
                                ITEM ACCOUNTING CLASS FROM 'BEGINNING' TO 'END'
                                ITEMS FROM SKT107 TO SKT107
                                OPER TOUSET

GENERAL INFORMATION
ITEM NUMBER SKT107          DESCRIPTION FAB ITEM          ALTERNATE ITEM NUMBER AMTPF0219
ITEM TYPE CODE            2  ENG DRW          QC CONTROL            0  ITEM PRICE CLASS

ITEM CLASS          CI          STD BCH QTY          5.000  SHELF LIFE          SALES TAX IND          T00

VALUE CLASS          S-NUMBER FLAG          BATCH/
LOT CTL            0  COMMISSION PCT          .000
INVENTORY CODE      01  LOW LEVEL          INSP ON RECEIPT      0  PRICE U/
M                  UNIT VOLUME          .000
DEPARTMENT          REP3  STD TOT CUM YLD          .648  DISCRETE ALLOC      0          VOLUME U/
M
ITM ACTG CLS        AA2  CUR TOT CUM YLD          .648  WARRANTY PER        36  UNIT WEIGHT          .000  TAX COMM C
ODE                TAXCOMM
CARRYING RATE       .000  AVG TOT CUM YLD          .000  WARRANTY PER U/M    WEIGHT U/M          EA  TAX WGHT/
UNIT               .0000
COUNTRY OF ORIG     SINGLE LEVEL COMP'S    1  SERIAL NUM REQD     0  SPEC GRAVITY        .0000  ORDER U/
M CLASS            EA
W/
H STK LOC          DIRECT USAGES          PRT ON SALES ANL     0  PACKING CODE          ITEM SALES GROUP
ABC
STOCKING U/M        EA  ROUTING OPERATIONS    4  KIT DOC PRINT OPT    0  BILL/LAD COM CD      AZP
STD SETUP COST/
LOT               650.65894737          SUPP WGHT          RECORD MAINTENANCE:
UNIT COST DEFAULT   .00000000          VENDR PRIMARY          SUPP WGHT U/
M                CREATED BSEDLOCK      07/03/**
BASE PRICE          .000  PUR TAX IND          TAX CLASS          CHANGED T
OUSET             08/01/**
BASE PRICE EFFECTIVE DATE          09/30/**

COSTING INFORMATION
ITEM NUMBER SKT107          RECAST FLAG          NO RECAST NEEDED
CUR UNIT COST          3,568.35817933          CUR COST STATUS CD          CUM F/O COST ROLL FACT .0000
STD UNIT COST          4,536.44664548          STD COST STATUS CD          LABOR HOURS          50.0000
CUR SETUP COST/LOT     639.25894737          CST TECHNIQUE CODE R          STD LOT SIZE          25.0000
-----CURRENT-----          LAST MAINT          TBL          -----THIS LEVEL-----          -----LOWER LEVELS-----
MATERIAL              06/20/**          308.60000000          .00000000
OUTSIDE OPERATIONS          282.40740741          .00000000
PURCHASE OVERHEAD          33.94600000
SETUP LABOR              18.72336842          .00000000
RUN LABOR                426.06725146          .00000000
SETUP MACHINE            07/01/**          7.50315789
RUN MACHINE              493.49415205
MFG OVERHEAD            997.61684210
OTHER COST 1              07/20/**          100.00000000
OTHER COST 2              07/20/**          200.00000000
OTHER COST 3              07/20/**          300.00000000
OTHER COST 4              07/20/**          400.00000000

-----STANDARD-----          LAST MAINT          TBL          -----THIS LEVEL-----          -----LOWER LEVELS-----
MATERIAL              339.46000000
OUTSIDE OPERATIONS          280.86419753
PURCHASE OVERHEAD          37.34060000
SETUP LABOR              19.12968421
RUN LABOR                361.03801170
SETUP MACHINE            7.50315789
RUN MACHINE              493.49415205
MFG OVERHEAD            997.61684210
OTHER COST 1              07/20/**          200.00000000
OTHER COST 2              07/20/**          400.00000000
OTHER COST 3              07/20/**          600.00000000
OTHER COST 4              07/20/**          800.00000000

PURCHASING INFORMATION
ITEM NUMBER SKT107          BUYER NUMBER          ACCOUNT          PURCHASE PRICE
EXTENDED DESCRIPTION-    FOR DOMESTIC USE ONLY
-WEIGHTED PERCENT-
LEAD TIME %              -TOLERANCE PERCENT-    RECEIPT REQUIRED          1  AVG ORDER SIZE
DELIVERY %                REC PLUS %              ALLOW DAYS EARLY          PURCH COMMODITY          125
QUALITY %                 REC MINUS %             SHIP VIA                  PRE-APPROVED            0
PRICE %                   ALPHA FACTOR            .000
EARLY DELIVERY %
LATE DELIVERY %
OVERSHIP %
UNDERSHIP %
    
```

```

NORTHCREEK IND.          ITEM MASTER FILE REPORT-COMplete      DATE  8/06/
** TIME 15.38.51 PAGE    2 AMVE41                               OPER  TOUSET
                               SEQUENCED BY ITEM
                               ITEMS FROM SKT107          TO SKT107
                               1 ITEMS LISTED
    
```

To print this report, use option 1 on the File Listings menu. Only fields that are not described on other Item Master reports are described here.

This sample report uses the XA default title for the cost element fields. The titles of these fields depend on what was entered in the PDM Control file for the cost elements.

The **BASE PRICE** fields do not appear on the report if you do not have the security level necessary for viewing and maintaining Item Master price fields.

The **UNIT CST DFT, CUR SETUP/LOT, STD SETUP LOT, CUR UNIT COST, STD UNIT COST**, and current or standard cost element fields do not appear on the report if you do not have the proper security level for viewing and maintaining Item Master cost fields.

Fields

ITEMS FROM/TO. The beginning and ending numbers identifying the range of items you selected for this report.

VENDORS FROM/TO. The beginning and ending numbers identifying the range of vendors you selected for this report.

ITEM TYPES FROM/TO. The beginning and ending code values for the range of item types you selected for this report.

ITEM CLASSES FROM/TO. The beginning and ending code values for the range of item classifications you selected for this report.

BUYERS FROM/TO. The beginning and ending numbers identifying the range of buyers you selected for this report.

ITEM ACCOUNTING CLASS FROM/TO. The beginning and ending code values for the range of item accounting classes you selected for this report.

VENDR PRIMARY. The number of the primary supplier of the item.

For more detail on the remaining fields, see report AMVT0.

Item Master File Report—Current Costs Sequenced By Item (AMVE42)

NORTHCREEK IND		ITEM MASTER FILE REPORT-CURRENT COSTS				DATE	8/07/
**	TIME 13.58.17	PAGE	1	AMVE42			
SEQUENCED BY ITEM							
		ITEMS FROM SKT107		TO SKT109			
ITEM NUMBER	DESCRIPTION	PURCHASE	UM I/T LABOR	ICLASS	ENGR DRAWING NO MACHINE	OPER TOUSET OVERHEAD/	
MISC	UNIT-COST						
SKT107	FAB ITEM						
	TL	591.00740741	EA 2	444.79061988	SKT	500.99730994	2031.56284210
3568.35817933	LL	.00000000		.00000000		.00000000	.00000000
SKT108	FAB ITEM2						
	TL	1267.90400000	EA 2	.00000000		.00000000	.00000000
1267.90400000	LL	.00000000		.00000000		.00000000	.00000000
SKT109	FAB ITEM3						
	TL	1021.32664000	EA 2	.00000000		528.00000000	.00000000
1549.32664000	LL	.00000000		.00000000		.00000000	.00000000

NORTHCREEK IND		ITEM MASTER FILE REPORT-CURRENT COSTS				DATE	3/07/
**	TIME 11.11.52	PAGE	2	AMVE42			
SEQUENCED BY ITEM							
		ITEMS FROM SKT107		TO SKT109			
3 ITEMS LISTED							

Only fields that are not described on other Item Master reports are described here.

Fields

ITEMS FROM/TO. The beginning and ending numbers identifying the range of items you selected for this report.

ITEM NUMBER. The unique alphanumeric identification of this item.

DESCRIPTION. The description or name of this item that appears on inquiries and reports.

UM (Unit of Measure). The unit used to express on-hand quantity and issue quantity.

I/T (Item Type Code). Code that best describes the type of item:

- 0 Phantom
- 1 Assembly or subassembly
- 2 Fabricated item
- 3 Raw material
- 4 Purchased item
- 9 User option (Special)
- F Feature
- K Kit

ICLASS (Item Class). A code that identifies the item class for this item according to how you classified your items into groups. FCST (if installed and interfacing) can use this field to classify items that have been coded as master level items (MLI code M or S).

ENGR DRAWING NO. The number used to identify a drawing of an item.

Note: The cost element titles on your report may have different titles depending on what was entered in PDM Control File Maintenance. Costs are shown for this-level (TL) and lower level (LL). The sum of the cost elements in both levels is shown in the unit cost field.

TL (This Level).

PURCHASE: The cost (current or standard) per unit for purchased parts, raw material, and outside operations for this item at this level.

PUR-OVERHEAD: The overhead cost (current or standard) per unit for purchased parts or raw material at this level.

LABOR: The direct cost (current or standard) per unit that is made up of run labor plus setup labor for this item at this-level.

LABOR-OVERHEAD: The indirect cost (current or standard) that is made up of run and setup machine costs, plus a portion of labor or machine cost for this item at this-level.

LL (Lower Level).

PURCHASE: The purchase part, raw material, and outside operations cost (current or standard) built up from lower levels for this item's product structure.

PUR-OVERHEAD: The overhead cost (current or standard) per unit for purchased parts or raw material based on current or standard costs, built up from lower levels for this item's product structure.

LABOR: The direct cost (current or standard) per unit that is made up of run labor plus setup labor (current or standard), built up from lower levels for this item's product structure.

LABOR-OVERHEAD: The indirect cost (current or standard) that is made up of run and setup machine costs plus a portion of labor or machine cost built up from lower levels for this item's product structure.

UNIT COST. The sum of this item's purchase, purchase overhead, labor, and labor overhead content (current or standard) for both this level and lower levels.

Item Master File Report—Purchase Item Detail (AMVE43)

NORTHCREEK IND.		ITEM MASTER FILE REPORT-PURCHASE ITEM DETAIL						DATE 10/10/						
** TIME 12.59.59 PAGE 1		AMVE43		SEQUENCED BY ITEM				OPER						
		ITEMS FROM 'BEGINNING'						TO 8341						
WEIGHTED PERCENT								TOLERANCE						
ITEM	BUYER	PKG	PURCHASE			SHIP	ACCOUNT NUMBER	PERCENT	LEAD	DLV	QLT	PRC		
DELIVERY-	SHIPPED		EARLY	LATE	OVR	UND		REC-	TIME					
NUMBER		CDE	PRICE											
REC+														
0115456		4	1.5000				3	1000	5	5	25	25	25	25
6	6	8												
0121214		2	261.5900				6	1000	5	5	25	25	25	25
5	5	3												
01258556		3	.7500				7	1000	5	5	25	25	25	25
3	3	4												
0147852		3	.0500				2	1000	5	5	25	25	25	25
7	5	10												
0154686		2	3.5000				6	1000	5	5	25	25	25	25
4	3	7												
015556462		1	.3200				4	1000	3	7	15	20	40	25
7	10	10												
01726		1	233.5000				1	1000	7	5	25	25	25	25
0	5	12												
11114569		1	212.5000				5	1000	5	5	25	25	25	25
3	0	15												
11212145		2	3.4890				9	1000	8	0	40	15	15	30
0	17	7												
1214598			5.0000				8	1000	0	0	30	30	30	30
4	2	12												
1236963		3	17,365.0000				3	1000	1	2	15	20	30	32
4	3	8												
125874		4	7.3500				7	1000	3	3	10	10	50	30
5	3	2												
128436		1	33.0000				9	1000	5	5	25	25	25	25
5	15	30												
1357412		4	17.3300				6	1000	3	0	5	25	35	35
7	4	3												
1456321		2	63.2500				4	1000	5	5	25	25	25	25
10	10	7												
1458923			176.0000				5	1000	3	6	7	7	35	51
2	3	5												
1478547		3	1,523.4000				8	1000	5	5	25	25	25	25
3	2	10												
154826		2	150.0000				1	1000	5	5	25	25	25	25
5	15	30												
159874		2	6.5000				6	1000	5	5	25	25	25	25
5	15	30												
1656554		3	1,600.0000				7	1000	5	5	25	25	25	25
5	5	8												
1741741		2	.6250				5	1000	5	5	25	25	25	25
1	1	0												
1753951		4	89.0000				9	1000	5	5	25	25	25	25
8	5	10												
1895623		2	26.7500				7	1000	5	5	25	25	25	25
6	0	0												
196325		4	633.1500				6	1000	5	5	25	25	25	25
5	0	15												
1963258		2	15.9500				3	1000	5	5	25	25	25	25
6	6	5												
1984573		1	66.5000				9	1000	4	4	55	5	20	20
7	5	8												
8322		1	7.0000				1000	0	0	0	0	0	0	0
0	0	0												
8323		1	.0000				1000	0	0	0	0	0	0	0
0	0	0												
8324		1	.0000				1000	0	0	0	0	0	0	0
0	0	0												
8330		1	.0000				1000	0	0	0	0	0	0	0
0	0	0												
8331		1	.0000				1000	0	0	0	0	0	0	0
0	0	0												
8332		1	.0000				1000	0	0	0	0	0	0	0
0	0	0												
8333		1	.0000				1000	0	0	0	0	0	0	0
0	0	0												
8340		1	.0000				1000	0	0	0	0	0	0	0
0	0	0												
8341		1	.0000				1000	0	0	0	0	0	0	0
0	0	0												

Only fields that are not described on other Item Master reports are described here.

Fields

ITEMS FROM/TO. The beginning and ending numbers identifying the range of items you selected for this report.

ITEM NUMBER. The unique alphanumeric identification of this item.

BUYER. The number of the buyer for this item.

PKG CDE (Packing Code). A field that is available for your use to code how the item should be packed for shipment.

PURCHASE PRICE. The purchase price for this item.

SHIP CODE. This field shows a code identifying the means by which this item is normally shipped.

ACCOUNT NUMBER. The account number to be invoiced for the item.

NATURE. If IFM is installed, **ACCOUNT NUMBER** is replaced with **NATURE**. This is an account revenue/expense code.

TOLERANCE PERCENT.

REC -: This field shows the user-defined percentage of receipts that can be underdelivered.

REC +: This field shows the user-defined percentage of receipts that can be overdelivered.

WEIGHTED PERCENT.

LEAD TIME: The percentage to be placed on variances between quoted and actual vendor lead times.

DLV: The percentage to be placed on variances between ordered and delivered quantities.

QLT: The percentage to be placed on reject quantities.

PRC: The percentage to be placed on variances between quoted and actual vendor prices.

EARLY DELIVERY: The percentage to be placed on early delivery.

LATE DELIVERY: The percentage to be placed on late delivery.

OVR SHIPPED: The percentage to be placed on overshipment.

UND SHIPPED: The percentage to be placed on undershipment.

Item Master File Report—Purchase Item Description (AMVE44)

NORTHCREEK IND.		ITEM MASTER FILE REPORT-PURCHASE ITEM DESCRIPTION	DATE 10/10/
**	TIME 13.11.09	PAGE 1 AMVE44	
		SEQUENCED BY ITEM	OPER
		ITEMS FROM 8322	TO 'END'

BUYER	ITEM NUMBER	ITEM DESCRIPTIONS
1	8322	STATIONERY 9 1/2 BY 12 WHITE BOND ENVELOPE WITH EMBLEM AND RETURN ADDRESS
1	8323	STATIONERY 8 BY 12 WHITE BOND LETTER HEAD
1	8324	STATIONERY 8 BY 12 WHITE BOND PLAIN
1	8330	DESK EXECUTIVE DESK MAHOGANY WITH BROWN LEATHER TOP INLAID WITH GOLD
1	8331	DESK EXECUTIVE DESK MAHOGANY PLAIN
1	8332	DESK SECRETARIAL DESK LEFT DROP
1	8333	DESK SECRETARIAL DESK RIGHT DROP
1	8340	CHAIR EXECUTIVE SWIVEL CHAIR BROWN LEATHER WITH SIDE ARMS
1	8341	CHAIR CONFERENCE CHAIR SWIVEL BLUE TWEED

9 ITEMS LISTED

Only fields that are not described on other Item Master reports are described here.

Fields

ITEMS FROM/TO. The beginning and ending numbers identifying the range of items you selected for this report.

BUYER. The number of the buyer for this item.

ITEM NUMBER. The unique alphanumeric identification of this item.

ITEM DESCRIPTIONS. The description or name of this item that appears on inquiries and reports.

End-Item Where-Used (AMEF75)

NORTHCREEK IND. END-ITEM WHERE-USED BY VENDOR 001011 DATE **/**/
 ** TIME 11.16.59 PAGE 1 AMEF75
 FROM-03410 TO 03419

NORTHCREEK IND. END-ITEM WHERE-USED BY ITEM W/O COMPONENTS DATE **/**/
 ** TIME 11.17.37 PAGE 1 AMEF75
 FROM-03595 TO 03903

NORTHCREEK IND. END-ITEM WHERE-USED DATE **/**/
 ** TIME 18.02.36 PAGE 1 AMEF75

COMPONENT ITEM NO.	DESCRIPTION PAINT/	ITEM TYPE 4	LOW LEVEL	02	UNIT MEAS	GL
VARNISH, BLUE VAR0010	ENGR DRAW					
LL PARENT		ENGINEERING		QUANTITY		ITEM
CD ITEM NO.	DESCRIPTION	DRAWING NUMBER		PER	UM	TYP
00 BICY004	DELUXE II, GIRL'S BICYCLE	41638		1.000	EA	1
00 BICY008	DELUXE II, BOY'S BICYCLE	41648		1.000	EA	1
00 SAE-BICY004	SAME AS BICY004 EXCEPT	ENGR DRAWING		1.000	EA	1
00 SAE-BICY008	SAME AS BICY008 EXCEPT			1.000	EA	1

Fields

COMPONENT ITEM NO. The item number of the component (highest level) used in this product structure.

DESCRIPTION. The description or name of the component item that appears on inquiries and reports.

ITEM TYPE (Item type code). Code that best describes the type of item:

- 0 Phantom
- 1 Assembly or subassembly
- 2 Fabricated item
- 3 Raw material
- 4 Purchased item
- 9 User option (Special)
- F Feature
- K Kit

Note: Item type code 9 (user option) may have purchase (material), purchase overhead (calculated), labor, labor overhead, and components. If you selected item type code 9, labor and labor overhead (this-level) are calculated from the routing (cost technique code = R) or from the Labor/Overhead Table (cost technique code = T). Or, if cost technique code was blank, the manually-entered material, labor, and labor overhead costs are used. PDM does not roll up lower-level costs when the item type is 9. Purchase overhead is calculated based on the Purchase Overhead Table code and user-entered material.

LOW LEVEL. Indicates the lowest level in any product structure in which this component item is directly used.

ENGR DRAW (Engineering drawing number). A number used to identify a drawing of the component item.

UNIT MEAS (Unit of measure). The unit of measure for the component item.

LL CD (Low-level code). This code indicates the lowest level in any product structure that this parent item is used.

PARENT ITEM NO. The item number of the parent used in this product structure.

DESCRIPTION. The description or name of the parent item that appears on inquiries and reports.

ENGINEERING DRAWING NUMBER. A number used to identify a drawing of the parent item.

QUANTITY PER. The quantity of the component item required to manufacture the requested standard batch quantity of the parent item.

UM (Unit of measure). The unit of measure for the quantity of the component item used in the parent item (quantity per).

ITEM TYP (Item type code). The item type code for the parent item.

Feature/Options Report (AMEF1)

NORTHCREEK IND.										FEATURE/OPTIONS REPORT										DATE **/**/									
** TIME 15.19.20 PAGE 1 AMEF1																													
S-NUMBER TEMPLATE NO. 1-----*																													
1 1 1 1 1 1 1 1 1 1 2																													
1 2 3 4 5 6 7 8 9 0 1 2 3 4 5 6 7 8 9 0																													

1 2 2 2 2 2 2 2 2 1 0 0 0 0 0 0 0 0 0 0																													
---E N D I T E M-----																													
ITEM NUMBER DESCRIPTION																													
BICY004 DELUXE II, GIRL'S BICYCLE										STD BATCH QTY										1.000									
-----F E A T U R E I T E M-----																													
* EFFECTIVITY DATES																													
S-																													
NO. FEAT SEQ										POS NO. NO. ITEM NUMBER DESCRIPTION										FROM TO									
01 01 0000										01- FR010FEAT										FRAME FEATURE,GIRL'S REQUIRED 1/01/** 1/12/**									
-----O P T I O N I T E M-----																													
* OPTION SEQ ITEM NUMBER DESCRIPTION										QUANTITY COST PLANNING																			
										NO. FACTOR FACTOR																			
2/01/** 12/15/**										1 0000 FR016G 16 INCH GIRL'S FRAME										1.000 .3000 .0000									
2/01/** 12/15/**										2 0000 FR014G 14 INCH GIRL'S FRAME										1.000 .4000 .0000									
2/01/** 12/15/**										3 0000 FR018G 18 INCH GIRL'S FRAME										1.000 .3000 .0000									
-----F E A T U R E I T E M-----																													
03 02 0000										02- FIN063FEAT										FINISH FEATURE REQUIRED 1/01/** 1/12/**									
-----O P T I O N I T E M-----																													
VARNISH, RED										01 0000 VAR0012 PAINT/																			
1.000 .1000 .0000										2/01/** 12/15/**																			
VARNISH, BLUE										02 0000 VAR0010 PAINT/																			
1.000 .1000 .0000										2/01/** 12/15/**																			
VARNISH, BROWN										03 0000 VAR0008 PAINT/																			
1.000 .1000 .0000										2/01/** 12/15/**																			
LACQUER, NEUTRAL										04 0000 VAR0006 PAINT/																			
1.000 .1000 .0000										2/01/** 12/15/**																			
2/01/** 12/15/**										05 0000 PNTWH084 WHITE PAINT, PLAIN										1.000 .1000 .0000									
2/01/** 12/15/**										06 0000 PNTGN086 GREEN PAINT, PLAIN										1.000 .1000 .0000									
2/01/** 12/15/**										08 0000 PNTBK090 BLACK PAINT, PLAIN										1.000 .1000 .0000									
2/01/** 12/15/**										09 0000 MTLPNT016 BLACK SHINY METALLIC PAINT										1.000 .1000 .0000									
2/01/** 12/15/**										10 0000 MTLPNT018 ORANGE METALLIC PAINT										1.000 .0500 .0000									
2/01/** 12/15/**										11 0000 MTLPNT020 PURPLE METALLIC PAINT										1.000 .0500 .0000									
-----F E A T U R E I T E M-----																													
REQD										04-05 03 0000 TRNFEAT05 TRAINING WHEELS FEATURE										NON-									
1/01/** 1/01/**										1/01/** 1/01/**																			
-----O P T I O N I T E M-----																													
1/01/** 1/01/**										01 0000 18INCH 18 INCH TRACK TRAINING WHEELS										1.000 .5000 .0000									
1/01/** 1/01/**										02 0000 15INCH 15 INCH TRANCK TRAINING WHEELS										1.000 .5000 .0000									
-----F E A T U R E I T E M-----																													
06-07 04 0000										RAF096										RACING ACCENT FEATURE NON-REQD									
-----O P T I O N I T E M-----																													
2/01/** 12/15/**										01 0000 WPS013 WHITE PLASTIC STRIPE										4.000 .5000 .0000									
2/01/** 12/15/**										02 0000 WLS013 WHITE LIGHTING STRIPE										6.000 .5000 .0000									
---E N D I T E M-----																													
BICY008										DELUXE II, BOY'S BICYCLE										STD BATCH QTY 1.000									

NORTHCREEK IND.	FEATURE/OPTIONS REPORT	DATE **/**/
** TIME 10.35.27	PAGE 5 AMEF1	
-----T O T A L S-----		
END-ITEMS	149	
END-ITEMS WITH FEATURES	4	
P/S FEATURES	16	
P/S OPTIONS	58	

Fields

S-NUMBER TEMPLATE NO. 1 (Feature/options template). An array of twenty elements, one position each. Each element can contain only 0, 1, or 2 for the maximum field size of each feature's option number. The maximum number of elements is 1520. Use the array as a template to lay over an S-number and locate the option selected for a given feature. The S-number is the field you enter to identify the options you want to associate with product features. The template is set up during application tailoring only when you select feature/options.

END ITEM.

ITEM NUMBER. The unique alphanumeric identification of this end item.

DESCRIPTION. The description or name of this end item that appears on inquiries and reports.

STD BATCH QTY (Standard batch quantity). The quantity of the parent item in a standard manufacturing batch. This quantity is relative to the quantity of each component item (quantity per) in the product structure.

FEATURE ITEM.

S-NO POS (S-Number position). The values in this field describe the relative position within the S-Number Template of each feature. For example, an item might have only two features. Feature 1 (with up to 35 options) would be located in position 01-01, while a feature 02 (with up to 1295 options) would be located in positions 02-03. The first three numbers in the S-Number Template would then be 1 and 02, and the entire template (FOTAB) would appear as 10200000000000000000.

FEAT NO. (Feature number). This field shows a numbered list (user-assigned) of the end-item's features and options of those features.

SEQ NO. (User sequence number). The user sequence number, together with the item number, is used to establish the sequence of the bills of material. This field appears only if user sequence was chosen during application tailoring.

ITEM NUMBER. The unique alphanumeric identification of this feature item.

DESCRIPTION. The description or name of this feature item that appears on inquiries and reports.

EFFECTIVITY DATES.

FROM (Effective date from). The date that this product structure relationship is effective. If the effective date from is preceded by an asterisk, the effectivity date is beyond the date that the item was last costed.

TO (Effective date to). The date this product structure relationship is no longer effective.

OPTION ITEM.

OPTION (Option number). The option number of this component for the feature shown.

SEQ NO. (Sequence number). The sequence number, together with the item number, is used to establish the sequence of the bills of material. This field appears only if user sequence was chosen during application tailoring.

ITEM NUMBER. The unique alphanumeric identification of this option (component) item.

DESCRIPTION. The description or name of this option that appears on inquiries and reports.

QUANTITY (Quantity per). The quantity of the component item used in the production of a standard batch quantity of the parent item.

COST FACTOR (Feature/options cost roll-up factor). This factor indicates to PDM product costing what portion of the component (option) is to be rolled up into the parent's (feature's) cost fields. This field is used only if you answered yes to the product costing question during application tailoring.

PLANNING FACTOR (Feature/options planning factor). This factor indicates to the MRP planning run what decimal fraction of the finished item uses this component.

TOTALS.

END-ITEMS. The total number of end items in this product structure.

END-ITEMS WITH FEATURES. The total number of end items with features in this product structure.

P/S FEATURES. The total number of features used by end-items.

P/S OPTIONS. The total number of options used by end-items.

Note: Features and options can be used multiple times by different end-items. The features and options totals include each usage.

Indented Bill (AMEF72)

NORTHCREEK IND.		INDENTED BILL		DATE		*/**/			
**	TIME 11.37.33	PAGE	1	AMEF72					
PARENT ITEM NO.		DESCRIPTION	TANK COVER ASSM	QTY	1	ITEM TYPE	1		
LOW LEVEL	02	ENGR DRAW	APS00A1			UNIT MEAS	EA		
34250-A		STANDARD BATCH QUANTITY		1.000					
RELATIVE	SEQ	COMPONENT	DESCRIPTION	ENGINEERING	QUANTITY	ITEM	OPT	FIRST	LT
EFFECTIVE	DATES		TRUNCATED	DRAWING NUMBER	PER	UM TYP	NO. OP	SEQ	ADJ
LEVEL	NO.	ITEM NO.							
FROM	TO								
.1	0000	03425	COVER	FC-6910	1.000	EA	2	0010	
.2	0000	99825-RM	PLASTIC SHEET		1.000	SF	3		
.1	0000	03592	PIN		2.000	EA	4	0010	
.1	0000	03595	LUG SUB-ASSEMBLY	AX-00190	1.000	EA	1	0010	
.2	0000	03592	PIN		1.000	EA	4	0010	
.2	0000	03594	LUG	FL-11487	1.000	EA	2	0010	
.3	0000	99544-RM	ROUND STOCK 5/8 DIA - CR		.500	FT	3		

Fields

QTY (Quantity). The number of batches (standard batch quantity) of the parent item to be manufactured.

ENGR DRAW (Engineering drawing number). A number used to identify a drawing of the parent item.

UNIT MEAS (Unit of measure). The unit of measure for the parent item.

RELATIVE LEVEL. The level in the bill of material for this component item relative to the parent's level. For example, if you select an item with a low-level code of 10, the indented bill for that item starts with a relative level of 1 even though the low-level code could be 11 or greater.

SEQ NO. (User sequence number). The user sequence number, together with the component item number, is used to establish the sequence of the bills of material. This field appears only if user sequence was chosen during application tailoring.

COMPONENT ITEM NO. The item number of the component (highest level) used in this product structure.

DESCRIPTION TRUNCATED. The short description of this component item.

ENGINEERING DRAWING NUMBER. A number used to identify a drawing of the component item.

OPT NO. (Option number). The option number of this component for retrievals where the parent is a feature.

FIRST OP SEQ (First operation). The number of the operation where this component item is first used. If a number was not entered, the component is assumed to be used at the first operation.

LT ADJ (Component lead time adjustment). The number of shop days prior to the parent's due date that this component item must be available (for assembling the parent).

EFFECTIVITY DATES.

FROM (Effective date from). The date that this product structure relationship is effective. If the effective date from is preceded by an asterisk, the effectivity date is beyond the date that the item was last costed.

TO (Effective date to). The date this product structure relationship is no longer effective.

For a description of the remaining fields on this report, see End-Item Where-Used (AMEF75) .

Product Structure Transaction List (AMEU5)

NORTHCREEK IND.		PAGE 1		PRODUCT STRUCTURE TRANSACTION LIST				DATE **/**/		UPDATE# 2	
TYPE	SOURCE	PARENT	SEQ	COMPONENT	QUANTITY	EFFECTIVE	DATES	FIRST	LT	F/	
O PLANNING	COST ROLL	BATCH	NO.	ITEM NO.	PER	FROM	TO	OPER	ADJ	FACTOR	
FACTOR	1	ITEM NO.	NO.	ITEM NO.	PER	FROM	TO	OPER	ADJ	FACTOR	
CHANGE		03424	0000	03421	1.000			0010	0	.0000	
.0000											
CHANGE		03424	0000	03422	2.000			0010	0	.0000	
.0000											
CHANGE		03424	0000	03423	1.000			0010	0	.0000	
.0000											
CHANGE		03424	0000	03592	2.000			0010	0	.0000	
.0000											
CHANGE		03424	0000	03593	2.000			0010	0	.0000	
.0000											
CHANGE		03425	0000	99825-							
RM	1.000			0	.0000	.0000					

NORTHCREEK IND.		PAGE 2		PRODUCT STRUCTURE TRANSACTION LIST				DATE **/**/		UPDATE# 6	
-----BATCH 2 ENTERED TRANSACTION STATISTICS-----											
TYPE	ENTERED	-----GENERATED-----			TOTAL						
		ADDS	CHANGES	DELETES							
SAME-AS-EXCEPTS	4	7			7						
MASS DELETES	1			5	5						
MASS REPLACES	1	1	2	0	3						
ADDS	1				1						
CHANGES	1				1						
DELETES	1				1						
STRUCTURE DELETES	1			5	5						
TOTAL TRANSACTIONS	10	8	2	10	23						

BATCH 2 RESULTING TRANSACTION STATISTICS

-----TRANSACTIONS-----	
TYPE	TOTAL
ADDS	9
CHANGES	3
DELETES	11
TOTAL TRANSACTIONS	23

NORTHCREEK IND.		PAGE 3		PRODUCT STRUCTURE TRANSACTION LIST				DATE **/**/		UPDATE# 6	
-P/S TRANSACTION LIST STATISTICS-											
-----TRANSACTIONS-----											
TYPE	TOTAL										
ADDS	9										
CHANGES	3										
DELETES	11										
TOTAL TRANSACTIONS	23										
PRODUCT STRUCTURE RUN ACTIVITY CONTROL NUMBER 9											

Fields

TYPE. The type of transaction performed on the Product Structure file.

Source. The source of a generated transaction:

- SAE header
- SAE add
- SAE change
- SAE delete
- Mass delete
- Mass replace.

PARENT ITEM NO. The item number of the parent used in this product structure.

SEQ NO. (User sequence number). The user sequence number, together with the component item number, is used to establish the sequence of the bills of material. This field appears only if user sequence was chosen during application tailoring.

COMPONENT ITEM NO. The item number of the component (highest level) used in this product structure.

QUANTITY PER. The quantity of the component item used in the production of a standard batch quantity of the parent item.

EFFECTIVE DATES.

FROM. The date that this product structure relationship is effective. If the effective date from is preceded by an asterisk, the effectivity date is beyond the date that the item was last costed.

TO. The date this product structure relationship is no longer effective.

FIRST OPER (First operation). The number of the operation where this component item is first used. If a number was not entered, the component is assumed to be used at the first operation.

LT ADJ (Component lead time adjustment). The number of shop days prior to the parent's due date that this component item must be available (for assembling the parent).

F/O (Feature/option code). This code shows additional information about the product structure relationship in regards to features and options of features.

blank The component is neither a feature nor an option.

N The component is a nonrequired feature; the parent is an end-item.

R The component is a required feature; the parent is an end-item.

O The component is an option; the parent is a feature.

PLANNING FACTOR (Feature/options planning factor). This factor indicates to the MRP planning run what decimal fraction of the finished item uses this component.

COST ROLL FACTOR (Feature/options cost roll-up factor). This factor indicates to PDM product costing what portion of the component (option) is to be rolled up into the parent's (feature's) cost fields. This field is used only if you answered yes to the product costing question during application tailoring.

BATCH. The number of the batch used to process these transactions.

Single Level Bill with Blow-Through (AMEF71)

NORTHCREEK IND.		SINGLE LEVEL BILL WITH BLOW-THROUGH		DATE **/**/					
**	TIME 10.32.54	PAGE	1	AMEF71					
PARENT ITEM NO.	DESCRIPTION	SPRAY UNIT	QTY	1	ITEM TYPE 1				
LOW LEVEL 00 99001	ENGR DRAW STANDARD BATCH QUANTITY		1.000	S-NO. **/**/**/**/**/**/**/**/**/**/**/	UNIT MEAS EA				
*/									
LL SEQ	COMPONENT	ENGINEERING	QUANTITY	ITEM	OPT	FIRST	LT		
EFFECTIVE DATES	DESCRIPTION	DRAWING NUMBER	PER	UM	TYP	NO.	OP	SEQ	ADJ
CD NO.	ITEM NO.								
FROM	TO								
01	0000	03590-F3	SWITCH FEATURE	FEATURE	NON-REQD	F			
02	0000	03590	AUTO SWITCH		1.000	EA	4	01	
01	0000	03591-F1	WHEEL FEATURE	FEATURE	REQUIRED	F			
02	0000	03591-08	WHEEL 8 IN DIA		2.000	EA	4	1	
02	0000	03591-10	WHEEL 12 IN DIA		2.000	EA	4	2	
02	0000	03591-12	WHEEL 18 IN DIA		2.000	EA	4	3	
01	0000	27006-F2	TANK SIZE FEATURE	FEATURE	REQUIRED	F			0010
02	0000	26006-20	TANK 8 BY 12 INCHES	A8300004	1.000	EA	1	01	
02	0000	26006-21	TANK 10 BY 18 INCHES	A8400004	1.000	EA	1	02	
02	0000	26006-22	TANK 12 BY 24 INCHES	A8500004	1.000	EA	1	03	
01	0000	27009-P	FINAL ASSEMBLY GROUP		1.000	EA	0		
02	0000	03021	VALVE		1.000	EA	4		0010
02	0000	03385	WRENCH		1.000	EA	4		0010
02	0000	03398	CORD BRACKET		1.000	EA	4		0010
02	0000	03410	BRACKET		1.000	EA	4		0010

Fields

S-NO. This is the S-number for the parent item. It identifies the options chosen for this parent item's feature or features.

LL CD (Low-level code). This code indicates the lowest level in any product structure that this component item is used.

SEQ NO. (User sequence number). The user sequence number, together with the component item number, is used to establish the sequence of the bills of material. The field appears only if user sequence was chosen during application tailoring.

ENGINEERING DRAWING NUMBER. A number used to identify a drawing of the component item.

OPT NO. (Option number). The option number of this component for retrievals where the parent is a feature.

FIRST OP SEQ (First operation). The number of the operation where this component item is first used. If a number was not entered, the component is assumed to be used at the first operation.

LT ADJ (Component lead time adjustment). The number of shop days prior to the parent's due date that this component item must be available (for assembling the parent).

FEATURE/OPTION NUMBER. This field shows a numbered list (user-assigned) of the end-item's features and options of those features.

SEQ NO. (User sequence number). The user sequence number, together with the component item number, is used to establish the sequence of the bills of material. The field appears only if user sequence was chosen during application tailoring.

For a description of the remaining fields on this report, see End-Item Where-Used (AMEF75) .

Single Level Where-Used (AMEF74)

NORTHCREEK IND.		SINGLE LEVEL WHERE-USED				DATE **/**/				
**	TIME 16.27.18	PAGE	1	AMEF74						
COMPONENT	ITEM NO.	DESCRIPTION ROUND STOCK 5/8 DIA -								
CRS		ITEM TYPE 3 LOW LEVEL 06								
99544-RM		ENGR DRAW				UNIT MEAS FT				
LL	PARENT	ENGINEERING				QUANTITY	ITEM	OPT	FIRST	LT
EFFECTIVE DATES		DRAWING NUMBER				PER	UM TYP	NO. OP	SEQ	ADJ
CD	ITEM NO.	DESCRIPTION								
FROM	TO									
03	27004-									
01	HANDLE		F8300006		1.000	EA	2	0010	2/01**	12/15/
**										
05	03904-C	PUMP SHAFT		FL-11401	.500	EA	2			
04	03594	LUG		FL-11487	.500	EA	2			

Fields

For a description of the fields on this report, see Indented Bill (AMEF72) and End-Item Where-Used (AMEF75) .

Summarized Bill (AMEF73)

NORTHCREEK IND.		SUMMARIZED BILL		DATE	1/13/
**	TIME 16.11.03	PAGE	1	AMEF73	
PARENT ITEM NO.	DESCRIPTION	SPRAY UNIT		QTY	1
1 LOW LEVEL 00					ITEM TYPE
99001	ENGR DRAW				UNIT MEAS E
A		STANDARD BATCH QUANTITY	1.000		
LOWEST LEVEL	COMPONENT ITEM NO.	DESCRIPTION	ENGINEERING DRAWING NUMBER	QUANTITY PER	ITEM UM TYP
1	03590-F3	SWITCH FEATURE		1.000	EA F
1	03591-F1	WHEEL FEATURE		2.000	EA F
1	27006-F2	TANK SIZE FEATURE		1.000	EA F
1	27009-P	FINAL ASSEMBLY GROUP		1.000	EA 0
.2	03021	VALVE		1.000	EA 4
.2	03385	WRENCH		1.000	EA 4
.2	03398	CORD BRACKET		1.000	EA 4
.2	03410	BRACKET		1.000	EA 4
.2	03415-1	SPRAY NOZZLE		1.000	EA 4
.2	03419	HINGE PIN		1.000	EA 4
.2	03424	TREADLE ASSEMBLY	AX00100	1.000	EA 1
.2	03428	STAND	PX00130	3.000	EA 2
.2	03443	MOTOR SUPPORT	PX001150	1.640	EA 2
.2	03578	TREADLE SPACER		2.000	EA 4
.2	03587	HINGE WASHER		2.000	EA 4
.2	03590	AUTO SWITCH		1.000	EA 4
.2	03591-08	WHEEL 8 IN DIA		2.000	EA 4
.2	03591-10	WHEEL 12 IN DIA		2.000	EA 4
.2	03591-12	WHEEL 18 IN DIA		1.000	EA 4
.2	03640	HINGE WASHER		2.000	EA 4
.2	05303	GASKET		1.000	EA 4
.2	05325	CONNECTOR		2.000	EA 4
.2	06014	NUT		2.000	EA 4
.2	07243	NUT		3.000	EA 4
.2	07652	SCREW		2.000	EA 4
.2	18250-C	TUBE CLAMP		1.000	EA 4
.2	26006-20	TANK 8 BY 12 INCHES	A8300004	1.000	EA 1
.2	26006-21	TANK 10 BY 18 INCHES	A8400004	1.000	EA 1
.2	26006-22	TANK 12 BY 24 INCHES	A8500004	1.000	EA 1
.2	27005-A	PUMPING UNIT	AX00400	1.000	EA 1
.2	27007-A1	BASE ASSEMBLY	AX00420	2.000	EA 1
.2	34180-A	RUBBER TUBE 1 X 3		1.000	EA 4
.2	34180-B	RUBBER TUBE 3/4 X 2		1.000	EA 4
.2	34250-A	TANK COVER ASSM	APS00A1	1.000	EA 1
.2	34440-A	STAND PIPE		1.000	EA 4
.2	46800-C	RUBBER TUBE 1/4 X 4		2.000	EA 4
.2	74955	BRACKET NUT		2.000	EA 4
.2	77583	BRACKET WASHER		2.000	EA 4
.2	79620-C	TANK TUBE		1.000	EA 4
.2	89214	HINGE NUT		1.000	EA 4
.3	03416	BOLT 1/4 BY 1		2.000	EA 4
.3	03417	BOLT 1/2 BY 2		4.000	EA 4
.3	03421	HINGE ARM	PX00060	1.000	EA 2
.3	03422	LEVER ARM	FC-6918	2.000	EA 2
.3	03423	TREADLE	PX00080	1.000	EA 2
.3	03425	COVER	FC-6910	1.000	EA 2
.3	03426	TUBE 8 IN DIA	A8300004	1.000	EA 2

Fields

The Summarized Bill of Material Report is produced in "Lowest Level" sequence.

LOWEST LEVEL. This indicates the lowest level in any product structure that this component item used.

For a description of the remaining fields on this report, see Indented Bill (AMEF72) and End-Item Where-Used (AMEF75) .

Production Facility Maintenance (AMVT7)

NORTHCREEK IND.		PRODUCTION FACILITY MAINTENANCE				DATE **/**/	
**	TIME 9.15.15	PAGE 1	AMVT7		OPER 53		
UPDATE# 137							
RECORD CHANGED	FACILITY ID	AA001	FACILITY TYPE	1	WORK CENTER		
		DESCRIPTION SAWS/SHEARING					
OLD VALUE	DEPARTMENT	DP20	PN FAC ACTG CLS	AB1	QUEUE TIME-DAYS	1.50	
	FOREMAN	JLF	PRIME LOAD CODE	3	AVG QUEUE TIME	35.84	
	LOCATION	B8E34	TRACKING SIGNAL	1.60	QUEUE MAD	.88	
	STD EFFICIENCY	.88	AVG STD OUTPUT	94.52	MACH RESOURCE NO.		
	AVG EFFICIENCY	.85	AVG ACTL OUTPUT	111.20	LABOR RESOURCE NO.		
	EXTRACT MACH BRKS	0	REPORTING METHODS	0	CLOCKING WINDOW	1:45	
	MACHINE RATE	2.000	RUN LABOR RATE	5.500	SETUP LABOR RATE	OVERHEAD RATE/PERCENT	OVERHEAD CODE
	CURRENT	2.000		5.500		300.000	B
	STANDARD	2.000		5.200		300.000	B
	-----LENGTH-----		-----CAPACITY-----				
	DESIRED	MAXIMUM	DESIRED	MAXIMUM	CALENDAR ID	XA	
SHIFT 1	7.5	9.0	3.0	4.0	POST TO OLDEST SCHED	0	
SHIFT 2	.0	.0	.0	.0	POST TO FUTURE SCHED	0	
SHIFT 3	.0	.0	.0	.0	FACILITY STOCK LOC	AWL04	
RECORD CHANGED	FACILITY ID	AA001	FACILITY TYPE	1	WORK CENTER		
		DESCRIPTION SAWS/SHEARING					
NEW VALUE	DEPARTMENT	DP20	PN FAC ACTG CLS	ABB	QUEUE TIME-DAYS	1.50	
	FOREMAN	A3Y	PRIME LOAD CODE	3	AVG QUEUE TIME	34.84	
	LOCATION	B8E34	TRACKING SIGNAL	1.60	QUEUE MAD	.88	
	STD EFFICIENCY	.88	AVG STD OUTPUT	94.52	MACH RESOURCE NO.		
	AVG EFFICIENCY	.85	AVG ACTL OUTPUT	111.20	LABOR RESOURCE NO.		
	EXTRACT MACH BRKS	0	REPORTING METHODS	0	CLOCKING WINDOW	1:45	
	MACHINE RATE	2.000	RUN LABOR RATE	5.500	SETUP LABOR RATE	OVERHEAD RATE/PERCENT	OVERHEAD CODE
	CURRENT	2.000		5.500		300.000	B
	STANDARD	2.000		5.200		300.000	B
	-----LENGTH-----		-----CAPACITY-----				
	DESIRED	MAXIMUM	DESIRED	MAXIMUM	CALENDAR ID	XA	
SHIFT 1	7.5	9.0	3.0	4.0	POST TO OLDEST SCHED	0	
SHIFT 2	.0	.0	.0	.0	POST TO FUTURE SCHED	0	
SHIFT 3	.0	.0	.0	.0	FACILITY STOCK LOC	AWL03	

NORTHCREEK IND.		PRODUCTION FACILITY MAINTENANCE CONTROL SHEET				DATE 8/31/	
**	TIME 9.15.15	PAGE 2	AMVT7		UPDATE# 10		
----- TRANSACTION UPDATE STATISTICS -----							
FACILITIES ADDED		FACILITIES CHANGED		FACILITIES DELETED			
1		1		1			

Fields

FACILITY ID. A user-assigned ID representing the facility.

DESCRIPTION. A description of this facility.

DEPARTMENT. The alphanumeric department ID associated with this facility.

FOREMAN. The identifier for the foreman for this facility.

LOCATION. The identifier for the location of this facility.

STD EFFICIENCY (Standard Efficiency). A standard you enter and maintain using Production Facility maintenance. It should be compared, by user, to average efficiency. It should reflect the expected value of average standard output divided by average actual output.

AVG EFFICIENCY (Average Efficiency). The average efficiency is the average of the standard output divided by the actual output of a period (in hours) for quantity worked. You enter and maintain this field using Production Facility maintenance. If PC&C is installed and interfacing, this field is also maintained or calculated automatically.

EXTRACT MACH BRKS (Extract Machine Breaks). A code that tells the PM&C application whether or not to extract break time from machine hours:

- 1 Extract break time.
- 0 Do not extract break time

REPORTING METHOD. The method used at the facility for reporting job transactions. The values for the methods are:

- 0 ON/OF reporting. Both ON (On) and OF (Off) transactions are required for each job. Jobs completed without both transactions are flagged as errors.
- 1 Off-only reporting with full ON override. OF transactions are required for each job. ON transactions are optional. If a job starts with an ON transaction, all information is used from the ON transaction. If an ON transaction does not exist, start times for the job are calculated from previous OF and T/A transactions and all other information is used from the OF transaction.
- 2 Off-only reporting with ON facility ID override. OF transactions are required for each job. ON transactions are optional. If the job starts with an ON transaction, the only information used from the ON transaction is the facility ID. All other information is used from the OF transaction. Start times are always calculated from previous OF and T/A transactions (even if an ON transaction exists).

CLOCKING WINDOW. The clocking window time defined for facilities using off-only reporting to group jobs that run concurrently and apportion time among those jobs. It can be any value from 0:00 to 9:59 (one second less than ten minutes). A value of 0:00 indicates that jobs at this facility are treated as if they are done consecutively.

FACILITY TYPE. A code representing the type of production facility this is:

- blank Work center (job shop)
- 1 Production line
- 2 Work station.

PN FAC ACTG CLS (Production Facility Accounting Class). Class, defined by your company, to group or classify orders or items by production facility for accounting purposes.

PRIME LOAD CODE. The prime load code is used in calculating the length of operation time for the forward scheduling routine. It identifies the critical operation

time factors necessary to schedule each operation's due date from its operation start date.

- 0 No hours accumulated
- 1 Run machine hours
- 2 Setup labor hours divided by setup crew size
- 3 (Setup labor hours divided by setup crew size) plus run machine hours
- 4 Run labor hours
- 5 (Setup labor hours divided by setup crew size) plus run labor hours.

TRACKING SIGNAL. The tracking signal is the sum of the deviations of the current queue from old average queue, calculated with each running of the PC&C Work Center Analysis report.

AVERAGE STD OUTPUT. The average standard output is the average of the standard time (hours) produced per period at a facility. The standard hours are based on the operation quantity worked and the time basis code.

AVERAGE ACTL OUTPUT. The average actual output is the average of the actual time (hours) worked per period at a facility.

Note: A period is defined as the time between order close-out and purges, which is not the same as month end period in the Inventory Management application.

PRODUCT LINE. A description that corresponds with the facility type code.

QUEUE TIME-DAYS. The expected number of days a job waits in the queue before work on it begins.

AVG QUEUE TIME. The average queue time is the average of total of standard hours of work remaining in a facility for a period of time.

QUEUE MAD. The mean absolute deviation (MAD) is a smoothed average of the differences (made positive if they are negative) between the current queue within a facility and the old average queue of that facility.

MACH RESOURCE NO.. This number, used by MPSP, identifies a machine in a facility as a critical resource. For example, a machine that affects major work flow in a facility.

LABOR RESOURCE NO.. This number, used by MPSP, identifies the labor in a facility as a critical resource. For example, a facility with limited available labor hours because of workers with special skills.

CURRENT MACHINE RATE. This rate, in cost per hour, is used with the run machine field of the associated routing to calculate the current run machine cost. PDM product costing can optionally use this in determining labor overhead content this-level in the associated Item Master B-records.

Standard machine rate is also shown.

CURRENT RUN LABOR RATE. This rate from the Labor/Overhead Table, in cost per hour, is used with the run labor field of the associated routing to calculate the current run labor cost. PDM product costing can optionally use this in determining current labor and labor overhead content this-level in the associated Item Master B-records.

Standard run labor rate is also shown.

CURRENT SETUP LABOR RATE. This rate from the Labor/Overhead Table, in cost per hour, is used with the setup labor hours field of the associated routing to calculate the current setup labor cost. PDM product costing can optionally use this in determining current labor and labor overhead content this-level in the associated Item Master B-records.

Standard setup labor rate is also shown.

CURRENT LABOR OVERHEAD RATE/PERCENT. The current labor overhead rate or percent from the Labor/Overhead Table used in the labor overhead calculation.

Standard labor overhead rate or percent is also shown.

CURRENT LABOR OVERHEAD CODE. This code indicates which of four methods (A, B, C, or D) is used to calculate current labor overhead this-level in the associated Item Master B-records. PDM product costing must be active and the cost technique code in associated Item Master B-records must be R if this code is used.

Standard labor overhead code is also shown.

DESIRED SHIFT LENGTH. The number of prime load code hours normally available for the duration of shifts 1, 2, or 3 for this facility.

MAXIMUM SHIFT LENGTH. The maximum number of prime load code hours available for the duration of shifts 1, 2, or 3 for this facility.

DESIRED SHIFT CAPACITY. The number of workers or machines normally available in this facility during shifts 1, 2, or 3.

MAXIMUM SHIFT CAPACITY. The maximum number of workers or machines available in this facility during shifts 1, 2, or 3.

CALENDAR ID. The identifier of the production calendar associated with this facility. This field is used by REP to explicitly define the days a production line is available for work.

POST TO OLDEST SCHED. The method used for applying transaction quantities in REP:

blank Defaults to the setting from the REPCTL record.

0 Off, posting is by individual schedules for all items on this production line.

1 On, multi-schedule posting, beginning with the oldest schedule, is used for all items on this production line.

POST TO FUTURE SCHED. The method used for applying transaction quantities in REP. The valid codes are:

blank Defaults to the setting from the REPCTL record.

0 Off, post to past and current schedules on this production line.

1 On, post to past, current, and future schedules on this production line.

FACILITY STOCK LOC. If the facility is a workstation, this field represents the line location where items are delivered and used in a production line operation. If the facility is a production line, then this field represents the stocking location where finished goods are stored. This field is used by REP as a default line location when setting up the Item-Line definition for a schedule controlled item.

Production Facility Report (AMV43)

NORTHCREEK IND.		PRODUCTION FACILITY REPORT					DATE **/**/				
**	TIME 16.24.32	PAGE	1	AMV43							
SEQUENCED BY FACILITY											
FACILITY ID		AA001	FACILITY TYPE		WORK CENTER	DESCRIPTION		SAWS/SHEARING			
DEPARTMENT		SAWS	QUEUE TIME-								
DAYS	2.00	AVG QUEUE TIME	34.81	DIRECT USAGES	0						
FOREMAN	NPM	PRIME LOAD CODE	3	QUEUE MAD	.72	EXTRACT MACH BREAKS					
0	LOCATION	B8E34	LAST MAINTAINED		5/16/						
**	TRACKING SIGNAL	1.46	PN FAC ACTG CLS		002						
0	STD EFFICIENCY	.88	AVG STD OUTPUT		94.52	MACH RESOURCE NO.	10005	REPORTING METHOD			
:00	AVG EFFICIENCY	.00	AVG ACTL OUTPUT		111.20	LABOR RESOURCE NO.	20005	CLOCKING WINDOW			
	POST OLDEST SCHED	0	POST FUTURE SCHED		0	CALENDAR ID	*****				
								----	LENGTH----	----	CAPACITY--
--	MACHINE	RUN LABOR	SETUP LABOR	OVERHEAD	OVERHEAD	DESIRED	MAXIMUM	DESIRED	MAXIM		
UM	RATE	RATE	RATE	RATE/							
PERCENT	CODE	SHIFT 1	7.5	9.0	3.0	4.0					
CURRENT	2.600	7.150	9.100	200.000	B	SHIFT 2	.0	.0	.0	.0	
STANDARD	2.600	6.760	8.710	200.000	B	SHIFT 3	.0	.0	.0	.0	
FACILITY STOCK LOC *****											
FACILITY ID		AS005	FACILITY TYPE		WORK CENTER	DESCRIPTION		PUMP ASSEMBLY			
DEPARTMENT		ASSY	QUEUE TIME-								
DAYS	3.00	AVG QUEUE TIME	121.21	DIRECT USAGES	11						
FOREMAN	CFB	PRIME LOAD CODE	4	QUEUE MAD	8.20	EXTRACT MACH BREAKS					
0	LOCATION	P8N88	LAST MAINTAINED		7/05/						
**	TRACKING SIGNAL	11.18	PN FAC ACTG CLS		002						
0	STD EFFICIENCY	.78	AVG STD OUTPUT		137.86	MACH RESOURCE NO.	10005	REPORTING METHOD			
:00	AVG EFFICIENCY	.72	AVG ACTL OUTPUT		191.47	LABOR RESOURCE NO.	20005	CLOCKING WINDOW			
	POST OLDEST SCHED	0	POST FUTURE SCHED		0	CALENDAR ID	*****				
								----	LENGTH----	----	CAPACITY--
--	MACHINE	RUN LABOR	SETUP LABOR	OVERHEAD	OVERHEAD	DESIRED	MAXIMUM	DESIRED	MAXIM		
UM	RATE	RATE	RATE	RATE/							
PERCENT	CODE	SHIFT 1	7.5	9.0	5.0	6.0					
CURRENT	.000	7.600	5.200	150.00	B	SHIFT 2	.0	.0	.0	.0	
STANDARD	.000	7.150	5.200	15.00	B	SHIFT 3	.0	.0	.0	.0	
FACILITY STOCK LOC ***											

Use this report to review production facility information.

This report is printed using option 2 (sequenced by facility) or 3 (sequenced by department) on the PDM Reports menu (AMEM03). It is also printed by using option 6 (by facility) or 7 (by department) on the CRP Reports menu (AMTM30).

Fields

FACILITY ID. An ID representing the facility.

FACILITY TYPE. Shows whether this facility is a work center, production line, or work station.

DESCRIPTION. A description of the facility.

DEPARTMENT. The department where this facility is located.

QUEUE TIME-DAYS (Standard queue time). The expected number of days a job can wait in the queue before work on it begins.

AV QUEUE TIME (Average queue time). The average queue time is the average of total of standard hours of work remaining in a facility for a period of time.

DIRECT USAGES. This field, used in maintenance, indicates the number of routing operation records on the facility where-used chain.

FOREMAN. A code that identifies the foreman for this facility.

PRIME LOAD CODE. The prime load code is used in calculating the length of operation time for the forward scheduling routine. It identifies the critical operation time factors necessary to schedule each operation's due date from its operation start date.

- | | |
|---|---|
| 0 | No hours accumulated |
| 1 | Run machine hours |
| 2 | Setup labor hours divided by setup crew size |
| 3 | (Setup labor hours divided by setup crew size) plus run machine hours |
| 4 | Run labor hours |
| 5 | (Setup labor hours divided by setup crew size) plus run labor hours |

QUEUE MAD. The mean absolute deviation (MAD) is a smoothed average of the differences (made positive if they are negative) between the current queue within a facility and the old average queue of that facility.

EXTRACT MACH BREAKS. This code indicates to the PM&C application whether you want to extract break time from machine hours. The valid codes are:

- | | |
|---|---------------------------|
| 0 | Do not extract break time |
| 1 | Extract break time |

LOCATION. A code that indicates the location of the facility.

LAST MAINTAINED. The date that the record for this production facility was last maintained.

TRACKING SIGNAL. The tracking signal is the sum of the deviations of the current queue from old average queue, calculated with each running of the PC&C Work Center Analysis report.

PN FAC ACTG CLS (Production facility accounting class). Class, defined by your company, to group or classify orders or items by production facility for accounting purposes.

STD EFFICIENCY (Standard efficiency). A standard you enter and maintain using Production Facility maintenance. It should reflect the expected value of average standard output divided by average actual output.

AVG STD OUTPUT (Average standard output). The average standard output is the average of the standard time (hours) produced per period at a facility. The standard hours are based on the operation quantity worked and the time basis code.

MACH RESOURCE NO. (Machine resource number). This number, used by MPSP, identifies a machine in a facility as a critical resource. For example, a machine that affects major work flow in a facility.

REPORTING METHOD. The method used at the facility for reporting job transactions. The values for the methods are:

- 0** ON/OF reporting. Both ON (On) and OF (Off) transactions are required for each job. Jobs completed without both transactions are flagged as errors.
- 1** Off-only reporting with full ON override. OF transactions are required for each job. ON transactions are optional. If a job starts with an ON transaction, all information is used from the ON transaction. If an ON transaction does not exist, start times for the job are calculated from previous OF and T/A transactions and all other information is used from the OF transaction.
- 2** Off-only reporting with ON facility ID override. OF transactions are required for each job. ON transactions are optional. If the job starts with an ON transaction, the only information used from the ON transaction is the facility ID. All other information is used from the OF transaction. Start times are always calculated from previous OF and T/A transactions (even if an ON transaction exists).

AVG EFFICIENCY (Average efficiency). The average efficiency is the average of the standard output divided by the actual output of a period (in hours) for quantity worked. You enter and maintain this field using Production Facility maintenance. If PC&C is installed and interfacing, this field is also maintained or calculated automatically.

AVG ACTL OUTPUT (Average actual output). The average actual output is the average of the actual time (hours) worked per period at a facility.

LABOR RESOURCE NO. This number, used by MPSP, identifies the labor in a facility as a critical resource. For example, a facility with limited available labor hours because of workers with special skills.

CALENDAR ID. The identifier of the production calendar used by this work center. This field is used by REP to explicitly define the days a production line is available for work.

CLOCKING WINDOW. The clocking window time defined for facilities using off-only reporting to group jobs that run concurrently and apportion time among those jobs. It can be any value from 0:00 to 9:59 (one second less than ten minutes). A value of 0:00 indicates that jobs at this facility are treated as if they are done consecutively.

POST OLDEST SCHED: The method used for applying transaction quantities. The valid codes are:

blank Defaults to the setting from the REPCTL record.

0 Off, posting is by individual schedules for all items on this production line.

1 On, multi-schedule posting, beginning with the oldest schedule, is used for all items on this production line.

POST FUTURE SCHED: The method used for applying transaction quantities. The valid codes are:

blank Defaults to the setting from the REPCTL record.

0 Off, post to past and current schedules on this production line.

1 On, post to past, current, and future schedules on this production line.

MACHINE RATE (Current machine rate). This rate in cost per hour, is used with the run machine field of the associated routing to calculate the current run machine cost. PDM product costing can optionally use this in determining labor overhead content this-level in the associated Item Master B-records. Standard machine rate is also shown.

RUN LABOR RATE (Current run labor rate). This rate from the Labor/Overhead Table, in cost per hour, is used with the run labor field of the associated routing to calculate the current run labor cost. PDM product costing can optionally use this in determining current labor and labor overhead content this-level in the associated Item Master B-records. Standard run labor rate is also shown.

SETUP LABOR RATE (Current setup labor rate). This rate from the Labor/Overhead Table, in cost per hour, is used with the setup labor hours field of the associated routing to calculate the current setup labor cost. PDM product costing can optionally use this in determining current labor and labor overhead content this-level in the associated Item Master B-records. Standard setup labor rate is also shown.

OVERHEAD RATE/PERCENT (Current labor overhead rate/percent). The current labor overhead rate or percent from the Labor/Overhead Table used in the labor overhead calculation. Standard labor overhead rate or percent is also shown.

OVERHEAD CODE (Current labor overhead code). This code indicates which of four methods (A, B, C, or D) is used to calculate current labor overhead this-level in the associated Item Master B-records. PDM product costing must be active and the cost technique code in associated Item Master B-records must be R if this code is used. Standard labor overhead code is also shown.

LENGTH (Shift length).

DESIRED: The number of prime load code hours normally scheduled for the duration of shifts 1, 2, or 3 for this facility.

MAXIMUM: The maximum number of prime load code hours available for the duration of shifts 1, 2, or 3 for this facility.

CAPACITY.

DESIRED: The number of workers or machines normally available in this facility during shifts 1, 2, or 3.

MAXIMUM: The maximum number of workers or machines available in this facility during shifts 1, 2, or 3.

FACILITY STOCK LOC. If the facility is a workstation, this field represents the line location where items are delivered and used in a production line operation. If the facility is a production line, then this field represents the stocking location where finished goods are stored. This field is used by REP as a default line location when setting up the Item-Line definition for a schedule controlled item.

Production Facility Where-Used (AMEG12)

NORTHCREEK IND.		PRODUCTION FACILITY WHERE-USED				DATE **/**/	
**	TIME 11.37.46	PAGE	1	AMEG12			
FACILITY ID	AS005	PUMP ASSEMBLY		FOREMAN C80	DEPARTMENT DP90	QUEUE 3.00	E
EFFICIENCY	90%						
				LOCATION 08N8		PRIME LOAD CODE 4	
---OPERATION---	TIME BASIS	----	----	---	---	---	---
SEQ DESCRIPTION		MACHINE	LABOR	TIME CREW	MOVE DAYS	NUMBER	ITEM-----DESCRIPTION
1000 OPER 100	HR/UNIT	.00	.00		.00	GEAR18	ONE-
SPEED GEAR ATTACHMENT							
6000	MIN/PIECE	.00	.00		.00	CHAIN94	36 INCH LONG-
LIFE CHAIN							
1000 FIRST INSPECTION	HR/						
UNIT 0.50	0.50	.00	BICY004			DELUXE II, GIRL'S BICYCLE	
0010 ASSEMBLE PUMP UNIT	PIECES/HR	.000000	.125000	2.00	.00	27005-A	PUMPING UNIT
0010 ASSEMBLE PUMP	HR/10 UNITS	.000	.200		.00	27003-20	PUMP ASSEMBLY
0010 ASSEMBLE PUMP SHAFT	PIECES/HR	.000000	.050000		.00	03904-	
A PUMP SHAFT ASSEMBLY							
0010 ASSEMBLE PUMP HOUSIN	PIECES/						
HR	.000000	.100000		.00	03025	PUMP HOUSING ASSEMBLY	

Fields

FACILITY ID. The ID of the facility followed by a description of the facility. If the time basis code is C, this ID represents a vendor (or group of vendors).

FOREMAN. A code that identifies the foreman for this facility.

DEPARTMENT. The department where this facility is located.

QUEUE (Standard queue time in days). The expected number of days a job can wait in the queue at this facility before work begins on it.

EFFICIENCY (Standard efficiency). A standard you enter and maintain using Production Facility maintenance. It should reflect the expected value of average standard output divided by average actual output.

LOCATION. A code that indicates the location of the facility.

PRIME LOAD CODE. Used in calculating the length of the operation time for the forward scheduling routine. It identifies the critical (constraining) operation time factors necessary to schedule each operation's due date from its operation start date. The valid codes are:

- 0 No hours accumulated
- 1 Run machine hours
- 2 Setup labor hours divided by setup crew size
- 3 (Setup labor hours divided by setup crew size) plus run machine hours
- 4 Run labor hours
- 5 (Setup labor hours divided by setup crew size) plus run labor hours.

OPERATION.

SEQ (Operation sequence number). The operation sequence number identifies the manufacturing steps necessary to complete an order. The PC&C forward scheduling routine follows the sequence of the operation within a manufacturing

order in order to schedule the start and completion dates of each operation. The estimated completion date for the whole order is the scheduled completion date of the last operation of that order.

DESCRIPTION. A description of the operation.

TIME BASIS . The explanation (literal) of the time basis code. This code is used to develop standard run labor time, run machine time, and run labor costs:

blank	hours per unit
C	Cost per piece (outside operation)
H	Hours per lot
M	Minutes per piece
P	Pieces per hour
1	Hours per 10 units
2	Hours per 100 units
3	Hours per 1,000 units
4	Hours per 10,000 units.

Note: The outside operation cost is printed under the "Cost per piece" literal for time basis code C.

RUN TIME.

MACHINE (Run machine time). This is the actual time in hours or minutes that the machine in the associated facility is expected to run to produce one unit of the associated item. PDM product costing can optionally use this field in determining the run machine portion of standard and current labor overhead content this-level in the associated Item Master B-record.

LABOR (Run labor time). This is the actual time in hours or minutes of labor expected in running production of the associated item. PDM product costing can optionally use this field in determining the run labor portion of standard and current labor and labor overhead content this-level in the associated Item Master B-record.

There are exceptions.

If the time basis code is C, which indicates a special usage for run labor, labor represents the per piece cost to produce one unit of the item. If the time basis code is P, labor represents the quantity per hour.

SETUP.

TIME (Setup labor time). The time in hours or minutes of labor to set up this operation. PDM product costing can optionally use this field in determining the labor setup portion of standard and current labor and labor overhead content this-level in the associated Item Master B-record.

CREW (Setup crew size). The number of people in the crew that does the setup of this operation. PDM product costing can optionally use this field in determining the machine setup portion of standard and current labor overhead content this-level in the associated Item Master B-record.

MOVE DAYS. The planned move time in days for a manufacturing operation. It is used in the manufacturing order scheduling routines.

PARENT ITEM.

NUMBER. The item number of the parent used in this product structure.

DESCRIPTION. The description of the parent used in this product structure.

Variable Capacity File Maintenance (AMVTC)

NORTHCREEK IND.		VARIABLE CAPACITY MASTER FILE MAINTENANCE										DATE 10/24/	
**	TIME 10.37.37	PAGE	1	AMVTC							OPER JAG	UPDATE#	5
ACTION	PRODUCT	START	MAINT			LENGTH			RESOURCE				
	FACILITY	DATE	DAYS	SHIFT 1	SHIFT 2	SHIFT 3	SHIFT 1	SHIFT 2	SHIFT 3	SOURCE DESCRIPTION			
1 - ADD	CS015	1/07/											
**	10	7.5			3.0	5.0	.0	PLANNED OVERTIME			10/24/**		
2 - BEFORE	AS005	1/06/											
**	99	8.0			3.0	5.0	.0	RESOURCE MOVE FROM AS095			3/23/**		
	AFTER	AS005	1/06/										
**	30	8.0			3.0	5.0	.0	TEMP RESOURCE FROM AS095			10/24/**		
3 - DELETE	LA035	2/14/											
**	99	8.0			3.0	3.0	.0	PLANNED OVERTIME			3/23/**		
9 - DELETE	AS095	2/14/											
**	10	7.5			2.0	5.0	.0	PLANNED OVERTIME (TEMP)			10/24/**		
	DELETE	AS095	5/01/**	3				1.0-					
	.0	.0	PLANNED MACHINE P.M.			10/24/**							

NORTHCREEK IND.		VARIABLE CAPACITY MASTER FILE MAINTENANCE										DATE 10/24/	
**	TIME 10.37.37	PAGE	2	AMVTC							OPER JAG	UPDATE#	5
CONTROL SHEET													
-----TRANSACTIONS-----													
TYPE						TOTAL							
1 - ADDS ENTERED						1							
2 - CHANGES ENTERED						1							
3 - DELETES ENTERED						1							
9 - DELETE ALL ENTERED						1							
TOTAL TRANSACTIONS						4							

Fields

ACTION. The type of activity performed on the record: add (A), delete (D), delete all (X), or in the case of change (C), the record as it was before maintenance and as it appears now.

PRODUCT FACILITY. The user-assigned identifier for the facility where this variable resource will be applied.

START DATE. The date this resource becomes available.

DAYS. The number of days this resource will be available.

SHIFT LENGTH. The number of hours that this resource will be effective during each shift.

RESOURCE. The number (plus or minus) of resource units applied during each shift.

SOURCE DESCRIPTION. A description of the variable resource.

MAINT DATE (Maintenance Date). The date this variable capacity record was last maintained.

Routing and Single Level Retrieval with Blow-Through (AMEG4)

NORTHCREEK IND.		ROUTING AND SINGLE LEVEL RETRIEVAL WITH BLOW-THROUGH		DATE 11/28/					
** TIME	9.21.10	PAGE	1	AMEG4					
PARENT ITEM NO.	19333	STRAWBERRY SHAMPOO	QTY	64,000	ITEM TYPE				
2	LOW LEVEL 01								
ENGR DRAW			STD BATCH QTY	64,000.000	UNIT MEAS O				
Z									
LL	SEQ	COMPONENT	I	ENGINEERING	OPTN	FIRST	L		
T	EFFECTIVE	DATES							
CD	NO.	ITEM NO.	DESCRIPTION	QUANTITY PER	UM	T	NUMBER		
J	FROM	TO					NUMB		
							OP		
							SEQ		
							AD		
02		21014	SODIUM C14-16 OLEFIN SULFONATE	.060	LB	4			
02		21246	AMONIUM LAUREL ETHER SULFATE	.025	LB	4			
02		21350	FORMALDEHYDE	.002	LB	4			
02		21372	LACTIC ACID	.001	LB	4			
02		21403	HYDROLYZED ANIMAL PROTIE	.001	LB	4			
02		21418	PEG-15 TALLOW POLYAMINE	.001	LB	4			
02		21470	SODIUM CHLORIDE	.005	LB	4			
02		21588	L-8614, STRAWBERRY FRAG	.001	LB	4			
02		21601	WATER - PURIFIED	.047	GL	4			
02		21620	FD&C RED #4 - DYE	.007	GM	4			
02		21621	D&C RED #33 - DYE	.001	GM	4			
02		21631	QUATERNIUM - 19	.001	LB	4			
02		21632	METHYLPARABEN	.001	LB	4			
02		21634	GLYCAL STERATE	.004	LB	4			
02		21648	2510 STRAWBERRY FRAG	.001	LB	4			
02		21758	PEG 6000 DISTILLED	.001	LB	4			
02		21764	COCAMIDE DEA	.008	LB	4			
WORK	YIELD	OPERATION	TBC	MACHINE	LABOR	TIME	CREW	MOVE	QUEUE
STD	CUR	AVG						DAYS	DAYS
MIX	0010	MAKE PRODUCT BASE	64,000.000000		64,000.000000	2.00	1	.00	1.00
.000	1.000	.000							
MIX	0020	HEAT TO 150 DEGREES	1	6,400.000000	12,800.000000	.00	1	.00	1.00
.950	.950	1.000							
MIX	0030	COOL TO 120 DEGREES	2	640.000000	320.000000	.00	1	.00	1.00
.000	1.000	1.000							
MIX	0040	MIX FRAGRANCE & DYE	3	32.000000	32.000000	.00	1	.00	1.00
.000	1.000	1.000							
TEST	0050	TEST COLOR	4	3.200000	1.600000	.00	1	.00	1.00
.970	.970	.000							
TEST	0060	TEST VISCOSITY	M	32,000.000000	16,000.000000	.00	1	.00	1.00
.970	.970	1.000							
SF055	0070		H	.500000	.500000	.00	1	.00	3.00
.000	1.000	.000							
AS099	0080		P	32,000.000000	.000000	.00	1	.00	2.00
.000	1.000	.000							

Fields

PARENT ITEM NO. The item number and description of the parent item used in this product structure.

QTY (Quantity—run time option). The number of batches (standard batch quantity) of the parent item to be manufactured.

ITEM TYPE (Item type code). Code that best describes the type of item:

- 0** Phantom
- 1** Assembly or subassembly

2	Fabricated item
3	Raw material
4	Purchased item
9	User option (Special)
F	Feature
K	Kit

Note: Item type code 9 (user option) may have material, outside operation costs, purchase overhead (calculated), labor, manufacturing overhead, and components. If you selected item type code 9, labor and manufacturing overhead (this-level) are calculated from the routing (cost technique code = R) or from the Labor/Overhead Table (cost technique = T). Or, if cost technique code was blank, the manually-entered material, labor, and manufacturing overhead costs are used. PDM does not roll up lower-level costs when the item type is 9. Purchase overhead is calculated based on the Purchase Overhead Table code and user-entered material.

LOW LEVEL. Indicates the lowest level in any product structure in which this item is directly used.

ENGR DRAWING. A number used to identify a drawing of the component item.

STD BATCH QUANTITY. The quantity of the parent item in a standard manufacturing batch. This quantity is relative to the quantity of each component item (quantity per) in the product structure.

UNIT MEAS (Unit of measure). The unit of measure for the parent item.

LL CD (Low-level code). This code indicates the lowest level in any product structure that this item is used.

SEQ NO. (User sequence number). The user sequence number, together with the component item number, is used to establish the sequence of the bills of material. This field appears only if you chose user sequence at application tailoring.

COMPONENT ITEM NO. The item number and description of the component (highest level) used in this product structure.

DESCRIPTION. The description or name of this component item that appears on inquiries and reports.

QUANTITY PER. The quantity of the component item required to manufacture the requested standard batch quantity of the parent item.

UM (Unit of measure). The unit of measure for the component item.

I T (Item type code). Code that best describes the type of item:

0	Phantom
1	Assembly or subassembly
2	Fabricated item
3	Raw material
4	Purchased item
9	User option (Special)
F	Feature
K	Kit

ENGINEERING NUMBER (Engineering drawing number). A number used to identify a drawing of the component item.

OPTN NUMB (Option number). The option number of this component for retrievals where the parent is a feature.

FIRST OP SEQ (First operation sequence). The first routing operation where this component is used.

LT ADJ (Component lead time adjustment). The number of shop days prior to the parent's due date that this component must be available (for assembling the parent).

EFFECTIVE DATES.

FROM (Effective from). The date that this product structure relationship is effective. If the effective date is preceded by an asterisk, the effective date is beyond the date that the item was last costed.

TO (Effective to). The date this product structure relationship is no longer effective.

WORK CENTER. The ID of the facility at which the operation is performed.

OPERATION.

SEQ (Operation sequence number). The operation sequence number identifies the manufacturing steps necessary to complete an order. The PC&C forward scheduling routine follows the sequence of the operation within a manufacturing order in order to schedule the start and completion dates of each operation. The estimated completion date for the whole order is the scheduled completion date of the last operation of that order.

MS (Milestone operation type). This code identifies the type of a sub-operation if it belongs to a milestone group.

B	The first sub-operation of milestone group with no activity reported
S	A sub-operation that is between the first and last sub-operations
J	The last sub-operation of a job shop milestone group
F	The last sub-operation of a flow shop milestone group.

DESCRIPTION. A description of the operation.

TBC (Time basis code). This code is used to develop standard run labor time, run machine time, and run labor costs:

blank	hours per unit
C	Cost per piece (outside operation)
H	Hours per lot
M	Minutes per piece
P	Pieces per hour
1	Hours per 10 units
2	Hours per 100 units
3	Hours per 1,000 units
4	Hours per 10,000 units.

RUN.

MACHINE (Run machine time). This is the actual time in hours or minutes that the machine in the associated facility is expected to run to produce one batch. This value is calculated by multiplying the run machine time (adjusted according to the time basis code) against the batch quantity. PDM product costing can optionally use this field in determining the run machine portion of standard and current overhead content this-level in the associated Item Master B-record.

LABOR (Run labor time). This is the actual time in hours or minutes of labor expected in running production of the associated item. This value is calculated by multiplying the run labor time (adjusted according to the time basis code) against the batch quantity. PDM product costing can optionally use this field in determining the run labor portion of standard and current labor and overhead content this-level in the associated Item Master B-record.

There are exceptions. If the time basis code is C, which indicates a special usage for run labor, run labor represents the per piece cost to produce one unit of the item. If the time basis code is P, run labor represents the quantity per hour.

SETUP.

TIME (Setup labor time). The time in hours or minutes of labor to set up this operation. PDM product costing can optionally use this field in determining the labor setup portion of standard and current labor and labor overhead content this-level in the associated item Master B-record.

CREW (Setup crew size). The number of people in the crew that does the setup of this operation. PDM product costing can optionally use this field in determining the machine setup portion of standard and current labor overhead content this-level in the associated Item Master B-record.

MOVE DAYS. The planned move time in days for a manufacturing operation. It is used in the manufacturing order scheduling routines.

QUEUE DAYS (Standard queue time in days). The expected number of days a job can wait in the queue after it has reached the facility before work on it begins.

YIELD.

STD (Standard operation yield). This percentage represents the budgeted or annual estimate of the amount of the parent item expected to remain in the production process at the end of an operation compared to the amount available at the start of the operation. This percentage is used for standard costing. The default is 1.000 (100%).

CUR (Current operation yield). This percentage represents today's or the near-term future expected amount of the parent item that remains in the production process at the end of an operation compared to the amount available at the start of the operation. This percentage is used for current costing, scheduling, and material requirements. The default is 1.000 (100%).

AVG (Average operation yield). This percentage is an historical average of the amount of the parent item that remains in the production process at the end of an operation compared to the amount available at the start of the operation. This average is based on past actual performance and is consistent with the averaging of actual hours reporting in PC&C, if it is installed and interfacing with PDM. The default is 1.000 (100%).

Line number. This field has no heading. The line number of the routing operation's additional description.

Additional routing operation description. This field has no heading. The additional descriptive text for a routing operation.

STATUS (Operation status). The operation status indicates whether an operation is active or inactive.

Routing List (AMEG11)

NORTHCREEK IND.		ROUTING LIST										DATE **/**/			
** TIME	08.39.44	PAGE	1	AMEG11											
ITEM NO.	19333	STRAWBERRY SHAMPOO										U/M OZ	I/T 2	ENGR	DRAW
---	OPERATION	---	TIME	----	RUN	-----	---	SETUP	---	FAC ID	QUEUE	MOVE	OPERATION	---	
SEQ MS	DESCRIPTION	DATE	LAST	BASIS	MACHINE	LABOR	TIME	CREW	DESCRIPTION	DAYS	DAYS	STATUS	STD	CUR	
AVG	MAINTAINED														
0010	MAKE PRODUCT	BASE	4	.00	1.00	2.00	1	MIX40			.00	ACTIVE	1.000	1.000	1
.000	2/25/**														
	OPER RUN QTY	AVERAGE	.00	.00	.00	MIX SHAMPOO									
		.000	TOOL NO.		TIMES REPORTED	00	DATE LAST REPORTED	*/**/**							
0020	HEAT TO 150	DEGREES	4	.00	2.00	.00	1	MIX			.00	ACTIVE	.950	.950	1
.000	2/25/**														
	OPER RUN QTY	AVERAGE	.00	.00	.00	MIX SHAMPOO									
		.000	TOOL NO.		TIMES REPORTED	00	DATE LAST REPORTED	*/**/**							
0030	COOL TO 120	DEGREES	4	.00	.50	00	1	MIX			.00	ACTIVE	1.000	1.000	1
.000	2/25/**														
	OPER RUN QTY	AVERAGE	.00	.00	.00	MIX SHAMPOO									
		.000	TOOL NO.		TIMES REPORTED	00	DATE LAST REPORTED	*/**/**							
001 USE OVEN NO 237															
0040	MIX FRAGRANCE & DYE	4	.00	.50	.00	1	MIX			.00	ACTIVE	1.000	1.000		
1.000	2/25/**														
	OPER RUN QTY	AVERAGE	.00	.00	.00	MIX SHAMPOO									
		.000	TOOL NO.		TIMES REPORTED	00	DATE LAST REPORTED	*/**/**							
0050	TEST COLOR	4	.00	.25	.00	1	TEST			.00	ACTIVE	.970	.970		
1.000	2/25/**														
	OPER RUN QTY	AVERAGE	.00	.00	.00	TEST SHAMPOO									
		.000	TOOL NO.		TIMES REPORTED	00	DATE LAST REPORTED	*/**/**							
0060	TEST VISCOSITY	4	.00	.25	.00	1	TEST			.00	ACTIVE	.970	.970		
1.000	2/25/**														
	OPER RUN QTY	AVERAGE	.00	.00	.00	TEST SHAMPOO									
		.000	TOOL NO.		TIMES REPORTED	00	DATE LAST REPORTED	*/**/**							
**	SELECT NO.	**													

Fields

ITEM NO. The item number and description of the item.

U/M (Unit of measure). The unit of measure for the item.

FAC ID. A user-assigned ID representing the facility.

DESCRIPTION. A description of this facility.

OPERATION STATUS. The operation status indicates whether an operation is active or inactive.

DATE LAST MAINTAINED. This is the date of the last transaction for this operation.

AVERAGE.

Average run machine time. The average run machine time is the average of actual run machine time in hours or minutes for each open operation for a particular routing record, adjusted by the time basis code.

Average run labor time. The average run labor time is the average of actual run labor time in hours or minutes worked on each open operation for a particular routing record, adjusted by the time basis code.

Average setup labor time. The average setup labor time is the average of actual setup labor time in hours or minutes worked on each open operation for a particular routing record.

Line number. The line number of the routing operation's additional description. This field appears to the left of additional routing operation description.

Additional routing operation description. The additional descriptive text for a routing operation.

OPER RUN QTY (Operation run quantity). The standard quantity of the end item you are processing at this facility.

TOOL NO. This field shows the number of the tool or tools needed to perform this operation.

TIMES REPORTED. This field shows the number of times that activity has been reported against this routing operation for this end-item.

DATE LAST REPORTED. This field shows the last date that activity was reported against this routing operation for this end-item.

For more details on the remaining fields, see Routing and Single Level Retrieval with Blow-Through (AMEG4) .

Fields

TRANS TYPE (Transaction type). The type of transaction: add routing, change routing, delete routing, routing delete, add description, change description, delete description, delete routing description, SAE header, SAE change, SAE delete, SAE add, and SAE additional description maintenance.

ITEM NUMBER. The unique alphanumeric identification of this item.

LINE NO. The line number of the routing operation's additional description.

DESCRIPTION. Additional routing operation description. The additional descriptive text for a routing operation.

OPER STAT (Operation status code). The operation status code is used to indicate an active or inactive operation.

00	Inactive
10	Active.

PROCESS NO. (Process sheet number). The process sheet number that is used to identify a user document that explains detailed instructions about processes required within this operation.

BATCH. This field shows the batch number to which you are currently attached.

OUTSIDE COST. The cost associated with any outside operation.

ST YL (Standard operation yield). This percentage represents the budgeted or annual estimate of the amount of the parent item expected to remain in the production process at the end of an operation compared to the amount available at the start of the operation. This percentage is used for standard costing. The default is 1.000 (100%).

CR YL (Current operation yield). This percentage represents today's or the near-term future expected amount of the parent item that remains in the production process at the end of an operation compared to the amount available at the start of the operation. This percentage is used for current costing, scheduling, and material requirements. The default is 1.000 (100%).

BEGINNING OPERATION. This field shows the beginning operation of the milestone.

ENDING OPERATION. This field shows the ending operation of the milestone.

MILESTONE GROUP TYPE (Milestone information). If you performed milestone maintenance, this line shows the function performed (define or remove), beginning and ending operation numbers, and the milestone group type.

For more details on the remaining fields, see Routing and Single Level Retrieval with Blow-Through (AMEG4) and Routing List (AMEG11) .

Cost Variations—Current to Standard (AMEH8)

NORTHCREEK IND.		COST VARIATIONS - CURRENT TO STANDARD				DATE 11/28/	
**	TIME 9.39.22	PAGE 1	AMEH8	FROM-9	TO-9999999999999999		
ITEM NUMBER	COST CODES		-----UNIT COSTS-----			BASE PRICE	---
GROSS MARGIN %---	DESCRIPTION	RF	CC	SC	U/M	I/C	I/
T	CURRENT	STANDARD		CURRENT	STANDARD	V A R I A T I O N	
-----	-----	-----	-----	-----	-----	-----	-----
OVERHEAD CONTENT	TOTAL VARIATION	PURCHASE CONTENT	PUR-OVERHEAD CONTENT	LABOR CONTENT	LAB-		
90-							
01240	25.75	LB 90	3	.25500000	.21830000	.294	13.27
	STS, .020X48X96, RAW						
		TL		.03670000			
	.03670000	LL					
90-							
01340	25.80	LB 90	3	.23150000	.23150000	.312	25.80
	STS, .026X48X100, RAW						
		TL					
		LL					
90-							
01440	25.85	LB 90	3	.24500000	.23060000	.311	21.22
	STS, .032X48X100, RAW						
		TL		.01440000			
	.01440000	LL					

Fields

The titles of the summary cost elements depend on the titles that were chosen in PDM Control file maintenance. This example depicts the default titles.

ITEM NUMBER. The unique alphanumeric identification of this item.

DESCRIPTION. The description or name of this item that appears on inquiries and reports.

COST CODES. The codes used to identify costs (current, standard, or both) for this item after product costing.

- blank** The item does not need costing.
- C** The item needs current costing.
- S** The item needs standard costing.
- B** The item needs current and standard costing.
- N** This is a new item and needs current and standard costing.
- O** This is a new item and needs current costing.
- P** This is a new item and needs standard costing.

CC (Current cost status code). This code shows the status of this item's current costs after product costing.

- blank** All costs are complete.
- D** The item's product structure, routing, or both are inconsistent with its item type.
- T** Some of the item's this-level costs are inconsistent with its item type.

L Some of the item's lower-level costs are inconsistent with its item type.

If the item has more than one condition, the highest priority code is shown. In order of priority, D is the highest, followed by T and L.

SC (Standard cost status code). This code shows the status of this item's standard costs after product costing. See **CC** for a list of the codes.

RF (Recost flag). This code is used to identify the manufacturing costs for this item that need to be costed.

U/M (Unit of Measure). The unit of measure for the item.

I/C (Item class). This code identifies the item class for this item according to how you classified your items into groups.

I/T (Item type code). Code that best describes the type of item:

0	Phantom
1	Assembly or subassembly
2	Fabricated item
3	Raw material
4	Purchased item
9	User option (Special)
F	Feature
K	Kit

Note: Item type code 9 (user option) may have material, outside operation costs, purchase overhead (calculated), labor, manufacturing overhead, and components. If you selected item type code 9, labor and manufacturing overhead (this-level) are calculated from the routing (cost technique code = R) or from the Labor/Overhead Table (cost technique code = T). Or, if cost technique code was blank, the manually-entered material, labor, and labor overhead costs are used. PDM does not roll up lower level costs when the item type is 9. Purchase overhead is calculated based on the Purchase Overhead Table code and user-entered material content.

UNIT COSTS. This field shows the sum of the current or standard purchase, purchase overhead, labor, and labor overhead contents for this item's this-level and lower levels.

Note: These are the default titles for these summary cost elements. The actual title that appears for these fields depends on the title that was entered in the PDM Control file.

BASE PRICE. The unit price entered for this item.

GROSS MARGIN%. This field shows the percentage of profit (current or standard) in base price as expressed in the following formula:

$$\frac{(\text{base price} - \text{unit cost})}{\text{base price}}$$

VARIATION.

PURCHASE CONTENT. These fields show the purchase part or raw material cost (current or standard) for this item at this-level and built up from lower levels.

PUR-OVERHEAD CONTENT (Purchase overhead content this and lower levels). These fields show the overhead cost (current or standard) per unit for purchased parts or raw material for this item at this-level and built up from lower levels.

LABOR CONTENT. This field shows the direct labor element—that is, run labor plus setup labor (current or standard) for this item at this-level and built up from lower levels.

LAB-OVERHEAD CONTENT (Labor overhead content this and lower levels). This field shows the labor overhead element—that is, run and setup machine plus a portion of labor or machine, of current or standard costs for this item at this-level and built up from lower levels.

Note: These are the default titles for these summary cost elements. The actual title that appears for these fields depends on the title that was entered in the PDM Control file.

TOTAL VARIATION. This field shows the difference between the current unit cost and the standard unit cost.

Indented Cost Sheet—Current or Standard (AMEG72)

NORTHCREEK IND.		INDENTED COST SHEET-STANDARD				DATE 11/28/	
**	TIME 10.01.05	PAGE 1	AMEG72				
PARENT ITEM NO. 99001		SPRAY UNIT					
ENGR DRAW		COST TECH R		I/T 1	LOW LEVEL	00	
LAST COSTED 11/28/**		EFFEC 11/28/**		U/M EA			
RECAST FLAG		-----U N I T C O N T E N T-----					
UNIT COST		PURCHASE*****		PUR-OVERHEAD*		LABOR*****	
COST STATUS L	LEVEL						LAB-OVERHEAD*
175.64366995	TL	.00000000	.00000000	2.02539682	7.64761905		
	LL	60.44491500	.00000000	27.02066281	78.50507627		
			STD BATCH QTY	1.000			
SEQ	COMPONENT	DESCRIPTION	COST	REL	U/M		
NO.	ITEM NO.	TRUNCATED	CODES	LEVEL	EA		
	03590-F3	SWITCH FEATURE	1		EA		
		NON-REQD FEATURE 03					
		TL	.75000000	.00000000	.00000000		
		LL	.00000000	.00000000	.00000000		
	03591-F1	WHEEL FEATURE	1		EA		
		REQUIRED FEATURE 01					
		TL	2.04975000	.00000000	.00000000		
		LL	.00000000	.00000000	.00000000		
	27006-F2	TANK SIZE FEATURE	1		EA		
		REQUIRED FEATURE 02					
		TL	.00000000	.00000000	.00000000		
		LL	8.49391500	.00000000	5.70641398	22.60543788	
	27009-P	FINAL ASSEMBLY GROUP	L 1		EA		
		QTY PER	1.500	ADJ	1.500		
		TL	4.01655000	.00000000	.00000000		
		LL	45.13470000	.00000000	21.31424883	55.89963839	
	03021	VALVE	.2		EA		
		QTY PER	1.500	ADJ	1.500		
		TL	.37500000	.00000000	.00000000		
		LL	.00000000	.00000000	.00000000		
	03385	WRENCH	.2		EA		
		QTY PER	1.500	ADJ	1.500		

Fields

The titles of the summary cost elements depend on the titles that were chosen in PDM Control file maintenance. This example depicts the default titles.

PARENT ITEM NO. The item number and description of the parent used in this product structure.

ENGR DRAW (Engineering drawing number). The number of the engineering drawing that defines this item.

COST TECH (Cost technique code). This code identifies the costing technique selected for this item.

blank Not costed

R Routing hours and facility rates

T Costing Labor/Overhead Table rates and percentages

I/T (Item type code). Code that best describes the type of item:

0 Phantom

1 Assembly or subassembly

2 Fabricated item

3 Raw material

- 4 Purchased item
- 9 User option (Special)
- F Feature
- K Kit

Note: Item type 9 may have material, labor, labor overhead, and components; but the component costs are not rolled up into the lower-level cost fields. However, item types 3 and 4 components does have their this-level material and purchase overhead content rolled up into the this-level purchase and purchase overhead content of an item type 9 parent. The total cost for an item type 9 is then calculated and rolled up into its parent item.

LOW LEVEL. Indicates the lowest level in any product structure in which this item is directly used.

LAST COSTED. The date that this item was last costed using PDM's full product costing.

EFFEC (Effective date). The date the costing is effective.

U/M (Unit of measure). The unit of measure for the parent item.

RECAST FLAG. This code is used to identify the manufacturing costs (current, standard, or both) for this parent item that need to be costed.

- blank** The item does not need costing.
- C** The item needs current costing.
- S** The item needs standard costing.
- B** The item needs current and standard costing.
- N** This is a new item and needs current and standard costing.
- O** This is a new item and needs current costing.
- P** This is a new item and needs standard costing.

COST STATUS. This code shows the status of this parent item's costs (current, standard, or both) after product costing.

blank All costs are complete.

D The item's product structure, routing, or both are inconsistent with its item type.

T Some of the item's this-level costs are inconsistent with its item type.

L Some of the item's lower-level costs are inconsistent with its item type.

If the item has more than one condition, the highest priority code is shown. In order of priority, D is the highest, followed by T and L.

UNIT CONTENT. The headings of the summary cost elements depend on the titles entered in the PDM Control file. The default titles shipped with the product appear in this sample.

LEVEL.

TL (This level). These fields show the unit contents for this level.

LL (Lower level). These fields show the unit contents built up from lower levels for this item.

UNIT COST. This field shows the sum of the (current or standard) cost contents for this item's this-level and lower levels.

STD BATCH QTY (Standard batch quantity). The quantity of the parent item in a standard manufacturing batch. This quantity is relative to the quantity of each component item (quantity per) in the product structure.

SEQ NO. (User sequence number). The user sequence number, together with the component item number, is used to establish the sequence of the bills of material. This field appears only if you chose user sequence at application tailoring.

COMPONENT ITEM NO. The item number of the component (highest level) used in this product structure.

DESCRIPTION TRUNCATED. A short description of the component item.

An asterisk (*) indicates the item was included in the last costing.

COST CODES. The Recost Flag and Cost Status codes for the component item.

REL LEVEL (Relative level). This field shows the product structure relationship of this component to the parent item shown on this report.

U/M (Unit of measure). The unit of measure for the component item.

Management Cost Summary—Current or Standard (AMEH7)

NORTHCREEK IND.		MANAGEMENT COST SUMMARY - STANDARD				DATE 11/28/	
**	TIME 9.38.18	PAGE 1	AMEH7	FROM-9	TO-9999999999999999		
ITEM NUMBER	RECOST CS					UNI	
T COST	GROSS						
DESCRIPTION	FL ST U/M I/C I/T	-----CONTENT VIEW-----				-----COST VIEW-----	
UNIT SELL PRICE	MARGIN %						
90-01240	LB 90 3	PURCHASE	.21830000	COMPONENT	.21830000		
STS, .020X48X96,RAW		PUR-					
OVERHD	LABOR TL	LABOR		L-	\$.21830000	25.75	
PURCHASE CONTENT TL			\$.294				
OVERHD TL	.21830000	LAB-OVERHD		P-OVERHD TL			
90-01340	LB 90 3	PURCHASE	.23150000	COMPONENT	.23150000		
STS, .026X48X100,RAW		PUR-					
OVERHD	LABOR TL	LABOR		L-	\$.23150000	25.80	
PURCHASE CONTENT TL			\$.312				
OVERHD TL	.23150000	LAB-OVERHD		P-OVERHD TL			

Fields

The titles of the summary cost elements depend on the titles that were chosen in PDM Control file maintenance. This example depicts the default titles.

ITEM NUMBER. The unique alphanumeric identification of this item.

DESCRIPTION. The description or name of this item that appears on inquiries and reports.

RECOST FL (Recost flag). This code is used to identify the manufacturing costs (current, standard, or both) for this item that need to be costed.

blank The item does not need costing.

C The item needs current costing.

S The item needs standard costing.

B The item needs current and standard costing.

N This is a new item and needs current and standard costing.

O This is a new item and needs current costing.

P This is a new item and needs standard costing.

CS ST (Cost status code). This code shows the status of this item's costs (current, standard, or both) after product costing.

blank All costs are complete.

D The item's product structure, routing, or both are inconsistent with its item type.

T Some of the item's this-level costs are inconsistent with its item type.

L Some of the item's lower-level costs are inconsistent with its item type.

If the item has more than one condition, the highest priority code is shown. In order of priority, D is the highest, followed by T and L.

U/M (Unit of measure). The unit of measure for this item.

I/C (Item class). This code identifies the item class for this item according to how you classified your items into groups.

I/T (Item type code). Code that best describes the type of item:

0	Phantom
1	Assembly or subassembly
2	Fabricated item
3	Raw material
4	Purchased item
9	User option (Special)
F	Feature
K	Kit

Note: Item type code 9 (user option) may have material, outside operation costs, purchase overhead (calculated), run labor, setup labor, manufacturing overhead, and components. If you selected item type code 9, labor and manufacturing overhead (this-level) are calculated from the routing (cost technique code = R) or from the Labor/Overhead Table (cost technique code = T). Or, if cost technique code was blank, the manually-entered material, labor, and manufacturing overhead costs are used. PDM does not roll up lower level costs when the item type is 9. Purchase overhead is calculated based on the Purchase Overhead Table code and user-entered material content.

CONTENT VIEW. These fields show total costs (total = this-level + lower-level). The headings of the summary cost elements depend on the titles entered in the PDM Control file. The default titles shipped with the product appear in this sample.

COST VIEW. The component field total shows all lower-level costs and this-level purchase and purchase overhead. The other fields show this-level labor, labor overhead, and purchase overhead. The headings of the summary cost elements depend on the titles entered in the PDM Control file. The default titles shipped with the product appear in this sample.

UNIT COST. This field shows the sum of the (current or standard) summary cost element contents for this item's level and lower levels.

UNIT SELL PRICE. The unit price entered for this item.

GROSS MARGIN%. This field shows the percentage of profit (current or standard) in base price as expressed in the following formula: base price - unit cost divided by base price.

Operations Cost Sheet—Current or Standard (AMEH41 and AMEH42)

NORTHCREEK IND.		OPERATIONS COST SHEET - CURRENT			DATE 7/27/	
92	TIME 14.52.26	PAGE 1	AMEH41			
PARENT ITEM NO. SKT107				COST TECHNIQUE CODE R		
TY 5.000				BATCH QTY 1 STD BATCH Q		
ENGR DRAWING				LAST COSTED 7/27/		
** UNIT MEAS EA						
RECAST FLAG COST STATUS						
SEQ COMPONENT	DESCRIPTION-			OPTION	EFFECTIVE DATES	EXTENDED
TRUNC. RECAST COST				FLAG STATUS QUANTITY	COMPONENT COST	NUMBER OP FROM T
NO. ITEM NO.						
O ADJ COST						
0001 SKK303	PURCHASED COMPONENT					
	342.5460000			.6172000	555.00000000	
FAC -----OPERATION-----						
SEQ MS DESCRIPTION	YIELD					
-----RUN/SETUP LABOR CONTENT-----	-----OVERHEAD-----					
FAC TIME TBC RATE	RUN LABOR	TIME RATE	MACHINE CONTENT	RATE	CODE	CONTENT
EFF RATE	SETUP LABOR	CREW	SETUP MACHINE			
STMP1 0010 STEP1	1.54320987					
R .00 C 16.500	.00000000	.00 44.00	.00000000	11.000	B	.00000000
171.29629629						
S .00 6.500	.00000000	1	.00000000			
1.00	OUTSIDE COST					
	171.29629629					
VEN01 0020 STEP 2	1.38888888					
R 150.00 2 6.000	12.50000000	100.00 5.000	6.94444444	8.000	C	17.51111104
46.55555549						
S 20.00 7.000	5.60000000	1	4.00000000			
1.00	OUTSIDE COST					
	.00000000					
IN040 0030 STEP 3	1.11111111					
R .00 C 5.500	.00000000	100.00 3.300	.00000000	28.600	D	.00000000
111.11111111						
S 20.00 4.400	.00000000	1	.00000000			
1.00	OUTSIDE COST					
	111.11111111					
ML025 0040 STEP 4	1.11111111					
R 40.00 8.840	413.56725145	40.00 10.400	486.54970760	200.000	A	980.10573098
1896.84921634						
S 40.00 7.792	13.12336842	5	3.50315789			
.95	OUTSIDE COST					
	.00000000					
TOTAL ACTIVE OUTSIDE OPERATION COST						
282.40740740						
PARENT OTHER COSTS -						
THIS LEVEL 1,000.00000000						
TOTAL ACTIVE EXTENDED COST						
3,568.35817923						

Fields

PARENT ITEM NO. The item number and description of the parent used in this product structure.

BATCH QTY (Batch quantity—run time option). The quantity of the parent item to be manufactured that is used to calculate setup content. It may differ from standard lot size.

Note: This report is not meant to duplicate the information produced by PDM costing routines. This is because labor and machine setup costs are calculated differently for the purposes of this report. PDM product costing apportions setup costs to the expected production run size by dividing by lot size, allowing you to project an expected cost of manufacture. For this report, the batch quantity is used as the divisor

to determine the setup cost per unit if the quantity is run. Production personnel should use this report as an aid in determining the cost of producing a particular batch size.

STD BATCH QTY (Standard batch quantity). The quantity of the parent item in a standard manufacturing batch. This quantity is relative to the quantity of each component item (quantity per) in the product structure.

ENGR DRAWING (Engineering drawing number). A number used to identify a drawing of an item.

S-NO. (S-number). Indicates the set of options for this end-item for this retrieval. The S-number has a field length of 20. One option number is entered for each feature for a specific end-item. The option numbers in the S-number correspond by location to the field size template established during application tailoring.

LAST COSTED. The date the item was last costed using PDM's full product costing.

UNIT MEAS (Unit of measure). The unit of measure for the parent item.

RECAST FLAG. This code is used to identify the manufacturing costs (current, standard, or both) for this parent item that need to be costed.

blank The item does not need costing.
C The item needs current costing.
S The item needs standard costing.
B The item needs current and standard costing.
N This is a new item and needs current and standard costing.
O This is a new item and needs current costing.
P This is a new item and needs standard costing.

COST STATUS. This code shows the status of this parent item's costs (current, standard, or both) after product costing.

blank All costs are complete.
D The item's product structure, routing, or both are inconsistent with its item type.
T Some of the item's this-level costs are inconsistent with its item type.
L Some of the item's lower-level costs are inconsistent with its item type.

If the item has more than one condition, the highest priority code is shown. In order of priority, D is the highest, followed by T and L.

SEQ NO (User sequence number). The user sequence number, together with the component item number, is used to establish the sequence of the bills of material. This field appears only if user sequence was chosen during application tailoring.

COMPONENT ITEM NO. The item number and description of the component used in this product structure.

DESCRIPTION-TRUNC. (Truncated component description). An abbreviated description of the component associated with the parent item.

RECAST FLAG. The Recost Flag code for the component item.

COST STATUS. The Cost Status code for the component item.

QUANTITY (Adjusted quantity per). The calculated quantity per of the component that has been factored to compensate for the operation yield. To calculate the Adjusted Quantity Per (Standard or Current), the ratio of cumulative yield through previous operation divided by the total cumulative yield is calculated for the operation and then multiplied by the Quantity Per.

COMPONENT COST. The cost of the component item associated with this parent item.

OPTION NUMBER. The option number of this component for retrievals where the parent is a feature.

EFFECTIVE DATES.

FROM. The date that this product structure relationship is effective.

TO. The date that this product structure relationship is no longer effective. If the effective date is followed by an asterisk, the effectivity date is beyond the date that the item was last costed.

EXTENDED ADJ COST (Extended adjusted cost). The component cost multiplied by the quantity or the sum of the labor, machine, and overhead contents.

FAC (Facility ID). The area where the routing operation is performed.

OPERATION.

SEQ (Operation sequence number). The operation sequence number identifies the manufacturing steps necessary to complete an order. The PC&C forward scheduling routine follows the sequence of the operation within a manufacturing order in order to schedule the start and completion dates of each operation. The estimated completion date for the whole order is the scheduled completion date of the last operation of that order.

MS DESCRIPTION (Operation milestone description). The description of the milestone operation type.

RUN/SETUP LABOR CONTENT.

TIME (Setup/run labor time). The labor time in hours or minutes required to run (R) or setup (S) this operation. PDM product costing can optionally use this field to determine the labor setup portion of standard and current labor and labor overhead content this-level in the associated Item Master B-record.

TBC (Time basis code). This code is used to develop standard run labor hours, run machine hours, and run labor costs:

blank	hours per unit
C	Cost per piece (outside operation)
H	Hours per lot
M	Minutes per piece
P	Pieces per hour
1	Hours per 10 units
2	Hours per 100 units
3	Hours per 1,000 units
4	Hours per 10,000 units.

RATE (Labor rate). The run (R) and setup (S) labor rates. The setup labor rate, in cost per hour, is used with the Setup Labor Time (SULHR) and Setup Crew Size (SUCSZ) fields of the associated routing to calculate the standard setup labor cost. PDM's product costing also uses this value to calculate labor and labor overhead content this-level in the associated Item Master B-records.

RUN LABOR. When Run Labor Time is extended by the Time Basis Code, this field shows the expected hours of run labor necessary to produce one unit of this item. If the time basis code is C, which indicates an outside operation, run labor represents the vendor's price to produce one item. If the item basis code is P, labor represents the quantity per hour. If the cost technique code is R, PDM product costing uses this field to determine the run labor portion of standard and current labor and manufacturing overhead content this-level in the associated Item Master B-record.

SETUP LABOR (Setup labor time). The labor time in hours or minutes required to set up this operation. PDM product costing can optionally use this field to determine the labor setup portion of standard and current labor and labor overhead content this-level in the associated Item Master B-record.

RUN/SETUP MACHINE CONTENT.

TIME (Setup machine time). The setup labor time divided by the setup crew size.

RATE (Run rate). The cost per hour to operate the machine.

CREW (Setup crew size). The number of people in the crew that does the setup of this operation. PDM product costing can optionally use this field in determining standard and current labor overhead content this-level in the associated Item Master B-record.

RUN MACHINE (Run machine time). When Run Machine Time is extended by the Time Basis Code, this is the time in hours or minutes that the machine in the associated facility is expected to run to produce one or more units (depending on the TBC) of the associated item. If the item basis code is C, which indicates a special usage, the Run Machine Time is not adjusted. PDM product costing can optionally use this field to determine the run machine portion of standard and current manufacturing overhead content this-level in the associated item Master B-record.

SETUP MACHINE. When Setup Machine Time is extended by the Time Basis Code, this is the time in hours or minutes required to set up the machine to run one or more units of the associated item.

OVERHEAD.

RATE (Overhead rate). This field shows the manufacturing overhead rate or percent used in the manufacturing overhead calculation. It is used in PDM costing formulas based on the overhead code (COCOD, SOCOD) you entered.

CODE (Overhead code). This code indicates which of four methods (A, B, C, or D) is used to calculate manufacturing overhead this-level in the associated Item Master B-records. The cost technique code in associated Item Master B-records must be R if this code is used.

Product Cost Update Report—Current or Standard Costs (AMEI30)

```

NORTHCREEK IND.
** TIME 9.43.28 PAGE 1 AMEI30 PRODUCT COST UPDATE REPORT DATE 11/28/
SELECT DATE 11/28/** CURRENT COSTS
LAST CURRENT 11/28/** AN INDIVIDUAL ITEM
ITEM NUMBER RCST U/ I I/ COST
FLAG /M T /C TECH -----THIS LEVEL
-----
LOWER LEVEL-----
DESCRIPTION
99001
99001 EA 1 10 R CURR OLD CURR NEW CURR OLD
CURR NEW
SPRAY UNIT ***** .00000000 .00000000 60.53491500
60.53491500
STD BATCH QTY 1.000 ***** .00000000 .00000000 .00000000
.00000000
CUR COST STATUS CD-
L ***** 2.02539682 1.89428571 27.14521837 27.14521837
***** 7.64761905 7.25428572 77.23007627
77.23007627

UNIT COST: CURR OLD 174.58322551 CURR NEW 174.05878107 VAR PCT
.3-
W AM-4866 COST STATUS FOR A LL COMP IS NOT BLANK
    
```

Fields

ITEM NUMBER. The unique alphanumeric identification of this item.

RCST FLAG (Recost flag). This code is used to identify the manufacturing costs (current, standard, or both) for this item that need to be costed.

- blank** The item does not need costing.
- C** The item needs current costing.
- S** The item needs standard costing.
- B** The item needs current and standard costing.
- N** This is a new item and needs current and standard costing.
- O** This is a new item and needs current costing.
- P** This is a new item and needs standard costing.

U/M (Unit of measure). The unit of measure for this item.

I T (Item type code). Code that best describes the type of item:

- 0** Phantom
- 1** Assembly or subassembly
- 2** Fabricated item
- 3** Raw material
- 4** Purchased item
- 9** User option (Special)
- F** Feature
- K** Kit

Note: Item type code 9 (user option) may have material, outside operation costs, purchase overhead (calculated), run labor, setup labor, manufacturing overhead, and components. If you selected item type code 9, labor and manufacturing overhead (this-level) are calculated from the routing (cost technique code = R) or from the Labor/Overhead Table (cost technique code = T). Or, if cost technique code was blank, the manually-entered material, labor, and manufacturing overhead costs are used. PDM does not roll up lower level costs when the item type is 9. Purchase

overhead is calculated based on the Purchase Overhead Table code and user-entered material content.

I/C (Item class). A code that identifies the item class for this item according to how you classified your items into groups.

COST TECH (Cost technique code). This code identifies the costing technique selected for this item.

blank Not costed
R Routing hours and facility rates
T Costing Labor/Overhead Table rates and percentages.

DESCRIPTION. The description or name of this item that appears on inquiries and reports.

STD BATCH QTY (Standard batch quantity). The quantity of the parent item in a standard manufacturing batch. This quantity is relative to the quantity of each component item (quantity per) in the product structure.

CUR COST STATUS CD (Cost status code). This code shows the status of this item's costs (current, standard, or both) after product costing.

blank All costs are complete.
D The item's product structure, routing, or both are inconsistent with its item type.
T Some of the item's this-level costs are inconsistent with its item type.
L Some of the item's lower-level costs are inconsistent with its item type.

If the item has more than one condition, the highest priority code is shown. In order of priority, D is the highest, followed by T and L.

THIS LEVEL. The headings on cost fields that appear here are based on the summary cost element headings entered in the PDM Control file. The old and new values appear.

Note: If the fields are user-maintained, the old this-level shown on the report reflects the maintenance done to the value during Item Master file maintenance. If the item has no components, routings, or if the cost technique code is blank, the new this-level value is the same as the old this-level value.

LOWER LEVEL. The headings on cost fields that appear here are based on the summary cost element headings entered in the PDM Control file. The old and new values appear.

UNIT COST. This field shows the sum of the (current or standard) cost fields for this item's this-level and lower-level. It shows the old and new values.

VAR PCT (Variance percentage). This field shows the percentage difference between the old and new unit costs.

Product Cost Simulation—Current and Standard Costs or Average Costs After Change By Percent (AMEI31)

```

NORTHCREEK IND.
** TIME 13.44.45 PAGE 1 AMEI31 PRODUCT COST SIMULATION DATE **/**/
SELECT DATE 7/22/** CURRENT AND STANDARD COSTS OPER
LAST SIMULATED 7/21/** AFTER CHANGE BY PERCENT

COST RCST U/ I I/
ITEM NUMBER FLAG /M T /C TECH -----THIS LEVEL-----
LOWER LEVEL-----
DESCRIPTION

MPA101 S EA 2 MPA1 R CURR AS-IS CURR SIM CURR AS-
IS CURR SIM
MPA ASSEMBLE 101 ***** 4.45000000 4.89500000 .00000000
.00000000
STD BATCH QTY 1.000 ***** .00000000 .00000000 .00000000
.00000000
CUR COST STATUS CD- ***** 66.00000000 66.00000000 .00000000 .00000000
***** 6.60000000 6.00000000 .00000000
.00000000
UNIT COST: CURR AS-
IS 77.05000000 CURR SIM 77.49500000 VAR PCT .5

IS STD SIM STD AS-IS STD SIM STD AS-
.00000000 ***** 4.45000000 4.89500000 .00000000
***** .00000000 .00000000 .00000000
.00000000
STD COST STATUS CD- ***** 6.00000000 66.00000000 .00000000
***** .60000000 6.60000000
UNIT COST: STD AS-
IS 11.05000000 STD SIM 77.49500000 VAR PCT 601.3
** E AM-4733 ITEM MAY CONTAIN INVALID COST ELEMENTS **
    
```

```

ITEM CLASS-**** CURRENT STANDARD
MATERIAL THIS LEVEL .100 .100
MACHINE RATE .000 .000
RUN LABOR RATE .000 .000
SETUP LABOR RATE .000 .000
OVERHEAD .000 .000
    
```

LABOR/OVERHEAD SIMULATION TABLE

CODE	LABOR RATE	CODE	OVERHEAD RATE/PERCENT
	.000		.000
	.000		.000
	.000		.000
	.000		.000

LAST MAINTAINED **NONE** **NONE**

SIMULATION TABLE NOT INITIALIZED

PURCHASE OVERHEAD SIMULATION TABLE

CODE	OVERHEAD PERCENT	CODE	OVERHEAD PERCENT
	.00		.00
	.00		.00
	.00		.00
	.00		.00

LAST MAINTAINED **NONE**

SIMULATION TABLE NOT INITIALIZED

```

CURRENT ITEMS SIMULATED 1
STANDARD ITEMS SIMULATED 1
    
```

Fields

ITEM NUMBER. The unique alphanumeric identification of this item.

DESCRIPTION. The description or name of this item that appears on inquiries and reports.

RCST FLAG (Recost flag). This code is used to identify the manufacturing costs (current, standard, or both) for this item that need to be costed.

blank The item does not need costing.
C The item needs current costing.
S The item needs standard costing.
B The item needs current and standard costing.
N This is a new item and needs current and standard costing.
O This is a new item and needs current costing.
P This is a new item and needs standard costing.

U/M (Unit of measure). The unit of measure for the item.

I T (Item type code). Code that best describes the type of item:

0 Phantom
1 Assembly or subassembly
2 Fabricated item
3 Raw material
4 Purchased item
9 User option (Special)
F Feature
K Kit

Note: Item type code 9 (user option) may have material, outside operation, purchase overhead (calculated), run labor, setup labor, manufacturing overhead, and components. If you selected item type code 9, labor and manufacturing overhead (this-level) are calculated from the routing (cost technique code = R) or from the Labor/Overhead Table (cost technique code = T). Or, if cost technique code was blank, the manually-entered material, labor, and manufacturing overhead costs are used. PDM does not roll up lower level costs when the item type is 9. Purchase overhead is calculated based on the Purchase Overhead Table code and user-entered material content.

I/C (Item class). A code that identifies the item class for this item according to how you classified your items into groups.

COST TECH (Cost technique code). This code identifies the costing technique selected for this item.

blank Not costed
R Routing hours and facility rates
T Costing Labor/Overhead Table rates and percentages.

THIS LEVEL. The headings on cost fields that appear here are based on the summary cost element headings entered in the PDM Control file. The old and new values appear.

LOWER LEVEL. The headings on cost fields that appear here are based on the summary cost element headings entered in the PDM Control file. The old and new values appear.

UNIT COST. This field shows the sum of the (current or standard) cost fields for this item's this-level and lower-level. It shows the old and new values.

VAR PCT (Variance percentage). This field shows the percentage difference between the as-is and the simulated unit costs.

CUR COST STATUS CD (Current cost status code). This code shows the status of this item's current costs after product costing.

blank All costs are complete.

D The item's product structure, routing, or both are inconsistent with its item type.

T Some of the item's this-level costs are inconsistent with its item type.

L Some of the item's lower-level costs are inconsistent with its item type.

If the item has more than one condition, the highest priority code is shown. In order of priority, D is the highest, followed by T and L.

STD BATCH QTY (Standard batch quantity). The quantity of the parent item in a standard manufacturing batch. This quantity is relative to the quantity of each component item (quantity per) in the product structure.

STD COST STATUS CD-L (Standard cost status code). This code shows the status of this item's standard costs after product costing. See **CUR COST STATUS CD** for a list of the codes.

Note: If you chose the run-time option to suppress warning messages on the report, a line is printed with *****WARNING MESSAGES HAVE BEEN SUPPRESSED*****.

Single Level Cost Sheet—Current or Standard, Single or Multi-Item, with or without Blow-Through (AMEG71)

NORTHCREEK IND.		SINGLE LEVEL COST SHEET-CURRENT OR STANDARD, SINGLE				DATE	9/28/
** TIME	13.41.42	PAGE	1	AMEG71			
PARENT ITEM NO. 99001		OR MULTI-ITEM, WITH OR WITHOUT BLOW-THROUGH					
ENGR DRAW		SPRAY UNIT					
LAST COSTED 8/04/**		COST TECH R I/T 1		LOW LEVEL 00			
RECOST FLAG B		EFFEC 8/04/**		U/M EA			
-----U N I T C O N T E N T-----							
UNIT COST		PURCHASE*****	PUR-OVERHEAD	LABOR*****	LAB-OVERHEAD*		
COST STATUS L	LEVEL						
	TL	.00000000	.00000000	1.89428571	7.25428572		
	LL	59.91256500	1.68134400	18.60699807	51.45366146		
S-NO.	01/01/00/00/00/00/00/00/00/00/00/00/		STD BATCH QTY	1.000	E AM-4733 ITEM MAY CONTAIN INVALID COST ELEMENTS		
SEQ	COMPONENT	DESCRIPTION	COST I	TECH T U/M			
NO.	ITEM NO.		R	2 EA			
	03426-B	TUBE 10 IN DIA		1.000			
		QTY PER	1.000	ADJ	1.000	.65805556	3.15052778
	TL	8.00040000	.00000000				
	11.80898334						
LLC 03	03426-C	TUBE 12 IN DIA		R	2 EA	.00000000	.00000000
		QTY PER	1.000	ADJ	1.000	.70166667	3.39350000
	TL	9.94110000	.00000000				
	14.03626667						
LLC 03	03590	AUTO SWITCH		4 EA		.00000000	.00000000
		QTY PER	1.000	ADJ	1.000	.00000000	.00000000
	TL	1.25000000	.00000000				
	1.25000000						
LLC 02	03590-F3	SWITCH FEATURE		F	NON-REQD FEATURE 03	.00000000	.00000000
	03591-F1	WHEEL FEATURE		F	REQUIRED FEATURE 01		
	03591-08	WHEEL 8 IN DIA		4 EA			
		OPTION-01 QTY PER	2.000	ADJ	2.000	.00000000	.00000000
	TL	1.49900000	.00000000				
	1.49900000						
LLC 02	03591-08	WHEEL 8 IN DIA		4 EA		.00000000	.00000000
		QTY PER	1.000	ADJ	1.000	.00000000	.00000000
	TL	.74950000	.00000000				
	.74950000						
LLC 02			.00000000			.00000000	.00000000

NORTHCREEK IND.		SINGLE LEVEL COST SHEET-CURRENT OR STANDARD, SINGLE				DATE	9/28/
** TIME	13.41.42	PAGE	4	AMEG71			
PARENT ITEM NO. 99001		OR MULTI-ITEM, WITH OR WITHOUT BLOW-THROUGH					
ENGR DRAW		SPRAY UNIT					
LAST COSTED 8/04/**		COST TECH R I/T 1		LOW LEVEL 00			
RECOST FLAG B		EFFEC 8/04/**		U/M EA			
-----U N I T C O N T E N T-----							
UNIT COST		PURCHASE	PUR-OVERHEAD	LABOR	LAB-OVERHEAD		
COST STATUS L	LEVEL						
	TL	.00000000	.00000000	1.89428571	7.25428572		
	LL	59.91256500	1.68134400	18.60699807	51.45366146		
S-NO.	01/01/00/00/00/00/00/00/00/00/00/00/		STD BATCH QTY	1.000	E AM-4733 ITEM MAY CONTAIN INVALID COST ELEMENTS		
SEQ	COMPONENT	DESCRIPTION	COST I	TECH T U/M			
NO.	ITEM NO.		R	4 EA			
	79620-C	TANK TUBE		1.500			
		QTY PER	1.500	ADJ	1.500	.00000000	.00000000
	TL	.12000000	.00000000				
	.12000000						
LLC 02			.00000000		.00000000	.00000000	.00000000
	COMPONENTS TOTAL	72.85580000	1.68134400	19.20211973	54.98575811		
	148.72502184						
OVERHEAD		\$9.14857143		ITEM LABOR & LABOR-			
				THIS LEVEL COST			
				ITEM UNIT COST			
				\$157.87359327			

The fields on the standard cost version of this report are identical.

Fields

The titles of the summary cost elements depend on the titles that were chosen in PDM Control file maintenance. This example depicts the default titles.

PARENT ITEM NO. The item number and description of the parent used in this product structure.

ENGR DRAW (Engineering drawing number). A number used to identify a drawing of the parent item.

COST TECH (Cost technique). This code identifies the costing technique selected for the parent item. The available codes are:

blank Not costed

R Routing hours and facility rates

T Costing Labor/Overhead Table rates and percentages.

I/T (Item type code). Code that best describes the type of item:

0 Phantom

1 Assembly or subassembly

2 Fabricated item

3 Raw material

4 Purchased item

9 User option (Special)

F Feature

K Kit

Note: Item type 9 may have material, outside operation costs, labor, manufacturing overhead, and components; but the component costs are not rolled up into the lower-level cost fields. However, item types 3 and 4 components do have their this-level material and purchase overhead content rolled up into the this-level material and purchase overhead content of an item type 9 parent. The total cost for an item type 9 is then calculated and rolled up into its parent item.

LOW LEVEL. PDM maintained field which indicates the lowest level in any product structure in which this parent item is directly used.

LAST COSTED. The date that this parent item was last costed using PDM's full product costing.

EFFEC (Effective date). Type in an effective date to use the effective dates in the file. If no date is entered, the date last costed, current or standard (CURDT or STDDT), is assumed.

U/M (Unit of measure). The unit of measure for the parent item.

RECAST FLAG. This code is used to identify the manufacturing costs (current, standard, or both) for this item that needs to be costed.

blank The item does not need costing.

C The item needs current costing.

S The item needs standard costing.

- B** The item needs current and standard costing.
- N** This is a new item and needs current and standard costing.
- O** This is a new item and needs current costing.
- P** This is a new item and needs standard costing.

COST STATUS. This code shows the status of this parent item's costs (current, standard, or both) after product costing.

blank All costs are complete.

D The item's product structure, routing, or both is inconsistent with its item type.

T Some of the item's this-level costs are inconsistent with its item type.

L Some of the item's lower-level costs are inconsistent with its item type.

If the item has more than one condition, the highest priority code is shown. In order of priority, D is the highest, followed by T and L.

UNIT CONTENT. The headings of the summary cost elements depend on the titles entered in the PDM Control file. The default titles shipped with the product appear in this sample.

LEVEL.

TL (This level). These fields show the unit content costs for this level.

LL (Lower level). These fields show the unit content costs built up from lower levels for this item.

PURCHASE (Purchase content). This field shows the purchase part or raw material cost (current or standard) for this item.

PUR-OVERHEAD (Purchase overhead content). This field shows the overhead cost (current or standard) per unit for purchased parts or raw material.

LABOR (Labor content). This field shows the direct labor element—that is, run labor plus setup labor (current or standard) for this item.

LAB-OVERHEAD (Labor overhead content). This field shows the labor overhead element—that is, run and setup machine plus a portion of labor or machine (current or standard), for this item.

UNIT COST. This field shows the sum of the (current or standard) summary cost element contents for this item's level and lower levels. It includes average of all features on this item.

Note: For an item type 9, the unit cost is the sum of this-level content fields. The component costs are not rolled up into the lower level cost fields. The lower-level cost fields have been forced to zero by product costing.

S-NO. This is the S-number for the parent item. It identifies the options chosen for this parent item's feature or features.

STD BATCH QTY (Standard batch quantity). The quantity of the parent item in a standard manufacturing batch. This quantity is relative to the quantity of each component item (quantity per) in the product structure.

SEQ NO. (User sequence number). The user sequence number, together with the component item number, is used to establish the sequence of the bills of material. This field appears only if user sequence was chosen during application tailoring.

COMPONENT ITEM NO. The item number and description of the component (highest level) used in this product structure.

Note: An asterisk (*) appears in front of the item number if the date the parent item was last costed is outside the effectivity date for the component.

DESCRIPTION. The description or name of this component item that appears on inquiries and reports.

QTY PER (Quantity per). The quantity of the component item required to manufacture the requested standard batch quantity of the parent item.

ADJ (Adjusted quantity per). The calculated quantity per of the component that has been factored to compensate for the operation yield. To calculate the Adjusted Quantity Per (Standard or Current), the ratio of cumulative yield through previous operation divided by the total cumulative yield is calculated for the operation and then multiplied by the Quantity Per.

OUTSIDE OPERATION COST THIS-LEVEL. This field shows the total cost this-level of all outside operations (time basis code = C) needed to manufacture the parent item.

ITEM UNIT COST. This field shows the sum of the (current or standard) purchase, purchase overhead, labor, and labor overhead contents for the item's this-level and lower levels for feature options selected.

Work-in-Process Cost Worksheet—Current, Standard, or Average Costs (AME86)

NORTHCREEK IND.		WORK-IN-PROCESS COST WORKSHEET - STANDARD				DATE 8/06/	
** TIME	14.54.12	PAGE	3	AME86	ITEMS FROM SKT107 TO SKT107		EFFECTIVE DATE 7/28/**
PARENT ITEM	SKT107	FAB ITEM					
ENGR DRAWING		COST TECHNIQUE	R	I/T 2	QUANTITY		1
LAST COSTED	7/28/**			U/M EA	STANDARD BATCH	QUANTITY	5.000
C U M U L A T I V E C O S T S -----							
OP SQ	DESCRIPTION	COMPONENT	LABOR AND OVERHEAD	SKK303	QTY PER	U/M	I/
T	PURCHASED COMPONENT				.617	EA	4
000000							342.54600000 .00
-----C U M U L A T I V E C O S T S -----							
M	- - - EXTENDED HOURS - - -		YIELD				
OP SQ S	DESCRIPTION	RUN LABOR	SETUP LABOR	OPER	COMPONENT	LABOR	
TOTAL	FACILITY EFF	RUN MACH	SETUP MACH	CUML	OUTSIDE OPERATION	OVERHEAD	
OVERHEAD AMT.		OUTSIDE COST			>> MACHINE CONTENT <<	IN	
START				1.000	342.54600000	.00000000	
2.54600000					.00000000	.00000000	34
0010	STEP 1	.00000000	.00	1.000	342.54600000	.00000000	
3.84229634	STMP1 1.00	.00000000	.00	.648	171.29629634	.00000000	51
	TIME BASIS = C	171.29629634				.00000000	
0020	STEP 2	2.08333333	20.00	.900	342.54600000	18.10000000	
0.39785190	VEN01 1.00	.00000000	20.00	.648	171.29629634	28.45555556	56
		.00000000				10.94444444	
0030	STEP 3	2.31481481	20.00	.720	342.54600000	18.10000000	
1.50896300	IN040 1.00	.00000000	20.00	.648	282.40740744	28.45555556	67
	TIME BASIS = C	111.11111110				10.94444444	
0040	STEP 4	46.78362571	42.10	.720	342.54600000	444.79061984	
8.35817918	ML025 .95	46.78362571	8.42	.648	282.40740744	1498.61415190	256
		.00000000				500.99730989	
PARENT OTHER COSTS -							
THIS LEVEL	1000.00000000					COST PER UNIT	356
8.35817918							

This report displays the cost buildup for a quantity of an item in terms of material, outside costs, labor, machine, and overhead costs added at each operation. Components are listed in ascending component sequence within the operation in which they are used.

A full setup cost is applied for each operation. Using this report you can determine the unit cost of making a quantity of the item. If you enter a standard lot size of the quantity, the unit cost will match to the unit cost calculated in product costing. Making more or less of the standard lot size will vary the unit cost of the item. Only active operations are shown.

Fields

EFFECTIVE DATE. The date that this product structure relationship is effective.

PARENT ITEM. The item number and description of the parent used in this product structure, followed by the item description.

ENGR DRAWING (Engineering drawing number). This number is used to identify a drawing of the parent item.

COST TECHNIQUE. This code identifies the costing technique selected to cost labor, machine, and overhead for this item. The available codes are:

blank Uses values in Item Master file; no calculations occur.
R Routing hours and facility rates.
T Costing Labor/Overhead Table rates and percentages.

I/T (Item type code). Code that best describes the type of item:

0 Phantom
1 Assembly or subassembly
2 Fabricated item
3 Raw material
4 Purchased item
9 User option (Special)
F Feature
K Kit

Note: Item type code 9 (user option) may have material, outside operation costs, purchase overhead (calculated), labor, manufacturing overhead, and components. If you selected item type code 9, labor and manufacturing overhead (this-level) are calculated from the routing (cost technique code = R) or from the Labor/Overhead Table (cost technique code = T). Or, if cost technique code was blank, the manually-entered material, labor, and manufacturing overhead costs are used. PDM does not roll up lower level costs when the item type is 9. Purchase overhead is calculated based on the Purchase Overhead Table code and user-entered material. The lower-level cost fields of an item type 9 are forced to zero, even if the item has components.

QUANTITY. The number of batches (standard batch quantity) of the parent item to be manufactured.

LAST COSTED. The date that this item was last costed using PDM's full product costing.

U/M (Unit of measure). The unit of measure for the parent item.

STANDARD BATCH QUANTITY. The quantity of the parent item in a standard manufacturing batch. This quantity is relative to the quantity of each component item (quantity per) in the product structure.

OP SQ (Operation sequence number). This field appears twice on the report. The operation sequence number and description on the top of the report identifies the operation where the component is first used. The operation sequence number and description on the bottom of the report identifies the manufacturing steps necessary to complete an order. For inactive operations, an 'I' appears to the left of the operation sequence number, and the cost of the routing step is not added into the cumulative total.

DESCRIPTION. The description or name of this component item that appears on inquiries and reports.

COMPONENT. The item number of the component (highest level) used in this product structure.

QTY PER (Quantity per). The quantity of the component item required to manufacture the requested standard batch quantity of the parent item.

UM (Unit of measure). The unit of measure for the component item.

CUMULATIVE COSTS.

COMPONENT. The cost of materials used to produce the specified quantity of the parent item. Cost is based on a component's unit cost multiplied by its adjusted quantity per value.

LABOR AND OVERHEAD. If the component is a phantom item and has a cost technique of R, a labor and overhead cost appears. Components for the phantom are listed and their costs listed under the component cost column.

I/T (Item type code). Code that best describes the type of item:

0	Phantom
1	Assembly or subassembly
2	Fabricated item
3	Raw material
4	Purchased item
9	User option (Special)
F	Feature
K	Kit

M S (Milestone operation). This field identifies the type of a sub-operation if it belongs to a milestone group.

B	The first sub-operation of a milestone group with no activity reported
S	A sub-operation that is between the first and last sub-operations
J	The last sub-operation of a job shop milestone group
F	The last sub-operation of a flow shop milestone group.

FACILITY. The work center where the operation is performed.

EFF (Efficiency). Shows how well this operation has met standards.

EXTENDED HOURS.

RUN LABOR. This is the actual time in hours or minutes of labor expected to produce one unit of the associated item. Routing times are extended by yield and efficiency.

SETUP LABOR. This is the actual time in hours or minutes of labor expected to setup for one unit of the associated item.

RUN MACH. This is the actual time in hours or minutes that the machine in the associated facility is expected to run to produce one unit of the associated item. Routing times are extended by yield and efficiency.

SETUP MACH. This cost is determined by Setup labor divided by the crew size.

OUTSIDE COST. This is the total computed outside operation cost, when the TBC code is C.

YIELD.

OPER (Operation yield). This percentage (standard, current, or average) represents the amount of the parent item expected to remain in the production process at the end of an operation compared to the amount at the start of the operation. Standard yield is based on a budgeted or annual estimate, current yield is based on the current environment, and average yield is an historical average based on past performance and consistent with the averaging of actual hours in PC&C (if installed and interfacing). The default is 1.000 (100%).

CUML (Cumulative yield through previous operations). The cumulative yield (standard, current, or average) is calculated by multiplying the cumulative yield for the previous operation and the operation yield for this operation. The default is 1.000 (100%).

START (Starting costing totals). All components whose operation where used field is blank will have their costs summarized and shown previous to the first operation.

CUMULATIVE COSTS.

COMPONENT. The component cost as displayed in the previous section.

OUTSIDE OPERATION. The cumulative cost of the outside operation at each operation.

LABOR/LAB-OVERHEAD (Cumulative labor/labor overhead). The cumulative labor cost at each operation.

TOTAL (Cumulative total). The cumulative total cost at each operation.

PARENT OTHER COSTS THIS LEVEL. The amount of other costs that have accumulated for this item.

T B (Time basis code). This code is used to develop standard run labor hours, run machine hours, and run labor costs. The available codes are:

blank	hours per unit
C	Cost per piece (outside operation)
H	Hours per lot
M	Minutes per piece
P	Pieces per hour
1	Hours per 10 units
2	Hours per 100 units
3	Hours per 1,000 units
4	Hours per 10,000 units.

COST PER UNIT. The total cost for each unit of the parent item.

OVERHEAD. The cumulative manufacturing overhead cost at each operation. This amount includes machine cost.

An informational message appears to inform you that the machine cost is included in the overhead amount above.

Calculate Cumulative Yield (AME78)

NORTHCREEK IND.			CALCULATE CUMULATIVE YIELD			DATE */**/				
**	TIME	8.49.01	PAGE	6	AME78					
PARENT	DESCRIPTION	OP	SEQ	MS	OP DESCRIPTION	---OPERATION YIELD---			--	
CUM THRU	PREV OPER--					STD	CUR	AVG	STD	CUR
AVG										
03426-										
C	TUBE 12 IN DIA							.000	.000	.000
BEFORE										
.000	BEFORE			0010	PREPARE ENDS	1.000	1.000	1.000	1.000	1.000
									1.000	1.000
1.000	AFTER			0020	INSPECT	1.000	1.000	1.000	1.000	1.000
.000	BEFORE								1.000	1.000
1.000	AFTER								1.000	1.000
03426-										
C	TUBE 12 IN DIA							1.000	1.000	32.483
AFTER										
03428	STAND								.000	.000
.000	BEFORE			0010	CUT TO LENGTHS	1.000	1.000	1.000	1.000	1.000
.000	BEFORE								1.000	1.000
1.000	AFTER			0020	SHAPE LEGS	1.000	1.000	1.000	1.000	1.000
.000	BEFORE								1.000	1.000
1.000	AFTER			0025	PRIME PAINT	1.000	1.000	1.000	1.000	.000
.000	BEFORE								1.000	1.000
2.483	AFTER			0030	FINISH PAINT	1.000	1.000	1.000	1.000	1.000
.000	BEFORE								1.000	1.000
2.443	AFTER			0040	WELD	1.000	1.000	1.000	1.000	1.000
.000	BEFORE								1.000	1.000
2.747	AFTER			0050	PRIME PAINT	1.000	1.000	1.000	1.000	1.000
.000	BEFORE								1.000	1.000
0.990	AFTER			0060	FINISH PAINT	1.000	1.000	1.000	1.000	1.000
.000	BEFORE								1.000	1.000
1.000	AFTER								1.000	1.000
03428	STAND								1.000	1.000
9.392	AFTER								1.000	1.000
03443	MOTOR SUPPORT								.000	.000
.000	BEFORE			0010	MILL SLOT	1.000	1.000	1.000	1.000	1.000
.000	BEFORE								1.000	1.000
1.000	AFTER			0020	DRILL 5/					
8 HOLES	1.000 1.000	1.000	1.000	1.000	1.000 1.000	.000	BEFORE		1.000	1.000
1.000	AFTER			0025	PRIME PAINT	1.000	1.000	1.000	1.000	1.000
.000	BEFORE								1.000	1.000
2.483	AFTER			0030	FINISH PAINT	1.000	1.000	1.000	1.000	1.000
.000	BEFORE								1.000	1.000
2.443	AFTER								1.000	1.000
03443	MOTOR SUPPORT								1.000	1.000
2.747	AFTER								1.000	1.000

Fields

PARENT. The item number of the parent used in this product structure.

DESCRIPTION. The description or name of the parent item that appears on inquiries and reports.

OP SEQ (Operation sequence). The operation sequence number and description identify the manufacturing steps necessary to complete an order. The PC&C forward scheduling routine follows the sequence of the operation within a manufacturing order in order to schedule the start and completion dates of each operation. The estimated completion date for the whole order is the scheduled completion date of the last operation of that order.

MS (Milestone operation). This field identifies the type of a sub-operation if it belongs to a milestone group.

- B** The first sub-operation of a milestone group with no activity reported
- S** A sub-operation that is between the first and last sub-operations
- J** The last sub-operation of a job shop milestone group
- F** The last sub-operation of a flow shop milestone group.

OP DESCRIPTION. A description of the manufacturing operation.

OPERATION YIELD.

STD (Standard operation yield). This percentage represents the budgeted or annual estimate of the amount of the parent item expected to remain in the production process at the end of an operation compared to the amount available at the start of the operation. This percentage is used for standard costing. The default is 1.000 (100%).

CUR (Current operation yield). This percentage represents today's or the near-term future expected amount of the parent item that remains in the production process at the end of an operation compared to the amount available at the start of the operation. This percentage is used for current costing, scheduling, and material requirements. The default is 1.000 (100%).

AVG (Average operation yield). This percentage is an historical average of the amount of the parent item that remains in the production process at the end of an operation compared to the amount available at the start of the operation. This average is based on past actual performance and is consistent with the averaging of actual hours reporting in PC&C, if it is installed and interfacing with PDM. The default is 1.000 (100%).

CUM THRU PREV OPER.

STD (Standard cumulative yield through previous operation). The first number printed is the total cumulative yield calculation from the last time that this report was printed. The other numbers show the standard cumulative yield through previous operation for each operation. This yield is calculated by multiplying the Standard Cumulative Yield for the previous operation and the Standard Operation Yield for this operation.

CUR (Current cumulative yield through previous operation). The first number printed is the total cumulative yield calculation from the last time that this report was printed. The other numbers show the current cumulative yield through previous operation for each operation. This yield is calculated by multiplying the Current Cumulative Yield for the previous operation and the Current Operation Yield for this operation.

AVG (Average cumulative yield through previous operation). The first number printed is the total cumulative yield calculation from the last time that this report was printed. The other numbers show the average cumulative yield through previous operation for each operation. This yield is calculated by multiplying the Average Cumulative Yield for the previous operation and the Average Operation Yield for this operation.

Calculate Adjusted Quantity Per (AME82)

COMPANY 01		CALCULATE ADJUSTED QUANTITY PER				DATE	*/**/	
** TIME	8.51.05	PAGE	54	AME82				
PARENT ITEM	19333	STRAWBERRY SHAMPOO			STD BATCH QUANTITY	64,000.000		
SEQ	COMPONENT				ADJ STD	ADJ CUR		ADJ
AVG	1ST							
NO	ITEM	DESCRIPTION	QTY PER	QTY PER	QTY PER	QTY PER	QTY	
PER	OPER							
	21014	SODIUM C14-						
16	OLEFIN SULFONATE	482.210	539.385	539.385	482.210	0010		
	21212	DL-						
	PANTHENOL	2.080	2.327	2.327	2.080	0010		
.480	21246	AMONIUM LAUREL ETHER SULFATE	202.480	202.480	226.488	226.488	202	
.480	0010							
.700	21350	FORMALDEHYDE	16.700	16.700	18.680	18.680	16	
.700	0010							
.170	21372	LACTIC ACID	4.170	4.170	4.664	4.664	4	
.170	0010							
.430	21403	HYDROLYZED ANIMAL PROTEIN	10.430	10.430	11.667	11.667	10	
.430	0010							
	21418	PEG-						
15	TALLOW POLYAMINE	4.170	4.664	4.664	4.170	0010		
.750	21470	SODIUM CHLORIDE	41.750	41.750	46.700	46.700	41	
.750	0010							
	21588	L-						
8614,	STRAWBERRY FRAG	10.850	12.136	12.136	10.850	0010		
	21601	WATER -						
	PURIFIED	383.000	428.412	428.412	383.000	0010		
	21620	FD&C RED #4 -						
	DYE	57.700	64.541	64.541	57.700	0010		
	21621	D&C RED #33 -						
	DYE	8.200	9.172	9.172	8.200	0010		
	21631	QUATERNIUM -						
19	21632	METHYLPARABEN	4.664	4.664	4.170	0010		
.260	0010							
.310	21634	GLYCAL STERATE	31.310	31.310	35.022	35.022	31	
.310	0010							
.420	21648	2510 STRAWBERRY FRAG	5.420	5.420	6.063	6.063	5	
.420	0010							
.170	21758	PEG 6000 DISTILLED	4.170	4.170	4.664	4.664	4	
.170	0010							
.120	21764	COCAMIDE	146.120	146.120	163.445	163.445	146	
.120	0010							

Fields

PARENT ITEM. The item number and description of the parent used in this product structure.

STD BATCH QUANTITY (Standard batch quantity). The quantity of the parent item in a standard manufacturing batch. This quantity is relative to the quantity of each component item (quantity per) in the product structure.

SEQ NO (User sequence number). The user sequence number, together with the component item number, is used to establish the sequence of the bills of material. This field appears only if you chose user sequence at application tailoring.

COMPONENT ITEM. The item number and description of the component (highest level) used in this product structure.

DESCRIPTION. The description or name of the component item that appears on inquiries and reports.

QTY PER (Quantity per). The quantity of this component item used in the production of a standard batch quantity of the parent item.

ADJ STD QTY PER (Standard adjusted quantity per). The calculated standard quantity per of the component that has been factored to compensate for the operation yield. To calculate the Standard Adjusted Quantity Per, the ratio of Standard cumulative yield through previous operation divided by the standard total cumulative yield is calculated for the operation and then multiplied by the Quantity Per.

ADJ CUR QTY PER (Current adjusted quantity per). The calculated current quantity per of the component that has been factored to compensate for the operation yield. To calculate the Current Adjusted Quantity Per, the ratio of Current cumulative yield through previous operation divided by the current total cumulative Yield is calculated for the operation and then multiplied by the Quantity Per.

ADJ AVG QTY PER (Average adjusted quantity per). The calculated average quantity per of the component that has been factored to compensate for the operation yield. To calculate the Average Adjusted Quantity Per, the ratio of Average cumulative yield through previous operation divided by the average total cumulative yield is calculated for the operation and then multiplied by the Quantity Per.

1ST OPER (First operation). The number of the operation where this component item is first used. If a number was not entered, the component is assumed to be used at the first operation.

Chapter 9. Forms

You can use several different forms for entering or changing Product Data Management data. Some of the forms are for entering file maintenance data using a PDM display, and some are for entering, changing, or deleting data in the offline files that you use to update master files. The PDM files and tables that have forms for these purposes are shown in this chapter.

Table 9-1. List of forms, sorted by form name

Form	ID	Page
Item Master File Maintenance—General Information	PM-01	9-3
Item Master File Maintenance—Additional Information	PM-02	9-4
Item Master File Maintenance—Costing Information	PM-03	9-5
Item Master Offline Maintenance (A-Record)	PM-26A, PM-26B	9-8
Item Master Offline Maintenance (B-Record)	PM-27	9-11
Item Master Offline Maintenance (C-Record)	PM-28	9-13
Labor/Overhead Table—Change Entry	PM-13	9-15
Product Structure File Maintenance	PM-14	9-16
Product Structure Offline Maintenance	PM-15	9-18
Production Facility File Maintenance	PM-23	9-39
Production Facility Offline Maintenance	PM-30A, PM-30B	9-41
Routing Description File Maintenance—Additional Operation	PM-21	9-35
Routing File Maintenance	PM-17	9-31
Routing File Milestone Group Maintenance	PM-18	9-33
Routing File Offline Maintenance	PM-29	9-37
Variable Capacity Master File Maintenance	TM-01	9-44

Table 9-2. (Page 1 of 2) List of forms, sorted by form ID

ID	Form	Page
PM-01	Item Master File Maintenance—General Information	9-3
PM-02	Item Master File Maintenance—Additional Information	9-4
PM-03	Item Master File Maintenance—Costing Information	9-5
PM-04	Item Master File Maintenance—Purchasing Information	9-6
PM-13	Labor/Overhead Table—Change Entry	9-15
PM-14	Product Structure File Maintenance	9-16
PM-15	Product Structure Offline Maintenance	9-18
PM-17	Routing File Maintenance	9-31
PM-18	Routing File Milestone Group Maintenance	9-33
PM-21	Routing Description File Maintenance—Additional Operation Descriptions	9-35
PM-23	Production Facility File Maintenance	9-39
PM-26A, PM-26B	Item Master Offline Maintenance (A-Record)	9-8
PM-27	Item Master Offline Maintenance (B-Record)	9-11
PM-28	Item Master Offline Maintenance (C-Record)	9-13
PM-29	Routing File Offline Maintenance	9-37

Table 9-2. (Page 2 of 2) List of forms, sorted by form ID

ID	Form	Page
PM-30A, PM-30B	Production Facility Offline Maintenance	9-41
TM-01	Variable Capacity Master File Maintenance	9-44

Item Master file maintenance—general information (PM-01)

	_Add
_Change *(A1)	
Display AMVT01_Delete	
Item number *(A15)	-----
Display AMVT02	
Item description *(A30)	-----
Engineering drawing number (A15)	-----
Stocking unit of measure *(A2)	--
Item type code *(A1)	-
Unit cost default (N19.8)	-----
Item class (A4)	----
Unit weight (N7.3)	-----
Weight unit of measure (A2)	--
Order unit of measure class (A2)	--
Warehouse stock location (A7)	-----
Alternate item (N15)	-----
Vendor number (primary) (A6)	-----
Department number (A4)	----
Item accounting class (A3)	----
Carrying rate (N3.3)	.---
Value class (A1)	-
Standard setup cost per lot (N19.8)	-----
Packing code (A2)	--
Standard batch quantity *(N11.3)	-----
Inventory code *(N2)	--
Bill of lading commodity code (A8)	-----
QC control flag (N1)	-
Purchase tax indicator (A3)	----
Shelf life (in days) (N4)	----
Sales tax indicator (A3)	----
Batch/lot control flag (N1)	-
Print on sales analysis (N1)	-
Inspect on receipt flag (N1)	-
Item class (A15)	-----

Use form PM-01 to maintain general item information in the Item Master File A-record.

The fields on this form are described under displays AMVT01 and AMVT02. See “AMVT01—Item Master File Maintenance (Select)” and “AMVT02—Item Master File—General Information (Add/Change/Delete/Set Defaults)” .

Item Master file maintenance—additional information (PM-02)

_Add

_Change *(A1)

Display AMVT01_Delete

Item number *	(A15)	-----
Display AMVT03		
Commission percent	(N7.3)	-----
Base price effective date	(N6)	-----
Base price	(N6.3)	-----
Item price class	(A4)	-----
Item price unit of measure	(A1)	--
Warranty period	(N5)	-----
Warranty period unit of measure	(A2)	--
Serial number required	(A1)	--
Country of origin code	(A3)	---
Item sales group	(A5)	-----
Specific gravity	(N9.4)	-----
Tax commodity code	(A8)	-----
Tax weight per unit	(N9.4)	-----
Supplemental weight	(N9.4)	-----
Supplemental weight unit of measure	(A2)	--
Unit volume		-----
Volume unit of measure		--

*Indicates a required field.

Use form PM-02 to maintain pricing/additional information in the Item Master File A-record.

Add/Change/Delete. A required field that indicates the maintenance function you want to perform.

See “AMVT03--Item Master File--Additional Information (Add/Change/Delete/Set Defaults)” in the *Inventory Management User’s Guide* for a description of the remaining fields on this form.

Item Master file maintenance—costing information (PM-03)

_ Add

_ Change * (A1)

_ Delete

Display AMVT01

Item number * (A15)

Display AMVT04

Cost technique code (A1)

_

Labor hours (N9.4)

Standard lot size (N10.3)

Current material this level (N19.8)

Standard material this level (N19.8)

Current outside operations this level (N19.8)

Standard outside operations this level (N19.8)

Current purchase overhead table code (A1)

_

Standard purchase overhead table code (A1)

_

Current setup labor this level (N19.8)

Standard setup labor this level (N19.8)

Current run labor table code (A1)

_

Current run labor this level (N19.8)

Standard run labor table code (A1)

_

Standard run labor this level (N19.8)

Current setup machine this level (N19.8)

Standard setup machine this level (N19.8)

Use form PM-03 to maintain additional cost information in the Item Master File B-record.

Add/Change/Delete. A required field that indicates the maintenance function you want to perform.

See “AMVT04—Item Master File—Costing Information (Add/Change/Delete/Set Defaults)” for a description of the remaining fields on this form.

Item Master file maintenance—purchasing information (PM-04)

- Add
 - Change (A1)*
 - Delete

Display AMVT01

Item number * (A15)

Display AMVT05

Extended descriptions (A40)

Buyer number (A5)

Account number (A15)
OR
Nature (A10)

Purchase price (N15.4)

Receipt required (N1)

-

Allowable days early (N3)

Receiving tolerance percent (positive) (N3)

Weighted lead time percent (N3)

Ship via (A3)

Receiving tolerance percent (negative) (N3)

Weighted delivery percent (N3)

Alpha factor (N3.3)

.---

Use form PM-04 to maintain purchasing or additional MRP information in the Item Master File C-record.

Add/Change/Delete. A required field that indicates the maintenance function you want to perform.

See “AMVT05—Item Master File—Purchasing Information (Add/Change/Delete/Set Defaults)” for a description of the remaining fields on this form.

Item Master offline file maintenance—A-record (PM-26A)

```

Transaction code (TRID) (A8)          - - - - -
(EOIA0101, EOIA02001, EOIA0301)**
Item number (ITNBR) (A15)*†         - - - - -
Item description (ITDSC) (A30) *     - - - - -
Item type code (ITTY) (A1)*          -
Item class (ITCLS) (A4)              - - - -
Inventory flag (INVFG) (N2)          - -
Standard batch quantity (SBQTY) (N11.3)* - - - - -
Unit cost default (UCDEF) (N19.8)    - - - - -
Unit of measure (UNMSR) (A2)        - -
Unit weight (WEGHT) (N7.3)          - - - - -
Warehouse stock location (WHSLC) (A7) - - - - -
Engineering drawing number (ENGNO) (A15) - - - - -
Vendor number (VNDNR) (A6)          - - - - -
Department number (DPTNO) (A4)      - - - -
Standard setup cost per lot (STDSU) (N19.8) - - - - -
Print on sales analysis flag (SAFLG) (N1) -
Carrying rate (CARRY) (N3.3)        - - - -
Value class (VALUC) (A1)             -
Packing code (PACKC) (A2)           - -
QC control flag (QCTYP) (N1)        -
Shelf life in days (QCDAY) (N4)     - - - -
Batch/log control flag (BLCF) (N1)  -
Inspect on receipt flag (INTYP) (N1) -
Discrete allocations flag (ALLOC) (N1) -
Purchase tax indicator (PTAXI) (A3)  - - -
Sales tax indicator (STAXI) (A3)     - - -

```

*Indicates a required field.

†Some fields are not required for all transaction codes.

**Use the appropriate transaction code for the type of maintenance you are going to perform.

Item Master offline file maintenance—A-record (PM-26B)

Item accounting class (ITAC) (A3)	---
Whole number conversion (A1)	-
Specific gravity (XBKMVA) (N9.4)	----- . -----
Commission percent (XBAPPC) (N7.3)	----- . -----
Warranty period (XBLBNB) (N5)	-----
Serial number required (XBIPST) (A1)	-
Kit external document print option (XBIQST) (A1)	-
Tax weight per unit (XBAAS2) (N9.4)	----- . -----
Supplemental weight (XBAAS2) (N9.4)	----- . -----
Unit of measure class (XBC8CD) (A2)	--
NAFTA prefer criteria (Z02E07) (A2)	--
UNAFPTA certification basis (Z9W407) (A1)	--
Bill of lading commodity code (XBFOCD) (A8)	-----
Weight unit of measure (XBCQCD) (A2)	--
Warranty unit of measure (XBHJCD) (A2)	--
volume weight of unit measure (XBAAPT) (A2)	--
EEC commodity code (XBAAXB) (A8)	-----
Country of origin (XBCOCD) (A3)	---
MRO item (MROI) (A1)	-
Add to spare part list (ATSP) (A1)	-
OEM number (OEMN) (A22)	-----
Item sales group code (ADSB) (A5)	-----
User field - switch A (UUSA) (A1)	-
User field - switch B (UUSB) (A1)	-
User field - switch C (UUSC) (A1)	-
User field - code A (UUCA) (A5)	-----
User field - code B (UUCB) (A5)	-----
User field - code C (UUC) (A5)	-----
User field - quantity 1 (UUQ1) (N6.3)	-----
User field - amount 1 (UUA1) (N8.2)	----- . -----
User field - date 1 (UUD1) (N7)	-----
User field - text 25 (UU25) (A25)	-----
User field - text 40 (UU40) (A40)	-----

Base price (N8.3)	----- . -----

*Indicates a required field.

Use forms PM-26A and PM-26B to enter information for the Item Master A-record into an offline file.

Transaction code. A required code that indicates the type of offline maintenance being performed on this record.

E0IA0101 Add

E0IA0201 Change

E0IA0301 Delete

See “AMVT01—Item Master File Maintenance (Select)”, “AMVT02—Item Master File—General Information (Add/Change/Delete/Set Defaults)”, and “AMVT03—Item Master File—Additional Information (Add/Change/Delete/Set Defaults)” for a description of the other fields on this form.

Item Master offline file maintenance—B-record (PM-27)

```

Transaction code (TRID) (A8)
(E0IB0100, EOIB0200, EOIB0300)**
Item number (ITNBR) (A15)*†
Standard lot size (LOTSZ) (N10.3)
Labor/overhead TL cost technique code (CTECH) (A1)
Labor hours (LABHR) (N9.4)
Current material this level (N19.8)
Standard material this level (N19.8)
Current outside operations this level (N19.8)
Standard outside operations this level (N19.8)
Current purchase overhead table code (A1)
Current setup labor this level (N19.8)
Standard setup labor this level (N19.8)
Current run labor table code (A1)
Current run labor this level
Standard run labor table code
Standard run labor this level
Current setup machine this
Standard setup machine this
Current run machine this
Standard run machine this
Current mfg overhead table
Current mfg overhead this
Standard mfg overhead table
Standard mfg overhead this
Current (Other cost 1) this
Standard (Other cost 1) this
Current (Other cost 2) this
Standard (Other cost 2) this
Current (Other cost 3)
Standard (Other
cost 3) this level (N19.8)
User field - switch A (UUSA) (A1)
User field - switch B (UUSB) (A1)
User field - switch C (UUSC) (A1)
User field - code A (UUCA) (A5)
User field - code B (UUCB) (A5)
User field - code C (UUCC) (A5)
User field - quantity 1 (UUQ1) (N6.3)
User field - amount 1 (UUA1) (N8.2)
User field - date 1 (UUD1) (N7)
User field - text 40 (UU40) (A40)

```

*Indicates a required field.

**Use the appropriate transaction code for the type of maintenance you are going to perform.

Use forms PM-27 to enter information for the Item Master A-record into an offline file.

Transaction code. A required code that indicates the type of offline maintenance being performed on this record.

E0IB0100 Add

E0IB0200 Change

E0IB0300 Delete

See “AMVT01—Item Master File Maintenance (Select)” and “AMVT04—Item Master File—Costing Information (Add/Change/Delete/Set Defaults)” for a description of the remaining fields on this form.

Item Master offline file maintenance—C-record (PM-28)

```

Item number (ITNBR) (A20)*†      -----
Buyer number (BUYNO) (A35)      -----
Account number (ACCTN) (A40)    -----
Or
Nature (A10)                    -----
Receipt required flag (RECRQ) (N1)  -
Allowable days early (ALLDE) (N3)  ---
Tolerance % receiving position
(TOLLPO) (N3)                  ---
Weighted lead time % (WILTM) (N3)  ---
Ship via code (VIACD) (A3)       ---
Tolerance % receiving negative
(TOLPC) (N3)                   ---
Weighted delivery % (WTDEL) (N3)   ---
Alpha factor (ALPHA) (N3.3)      ---
Weighted quality % (WTQUA) (N3)   ---
Weighted price % (WTPRC) (N3)     ---
Weighted early delivery % (WTEDL) (N3) ---
Weighted late delivery % (WTLDL) (N3) ---
Weighted overship % (WTVOS) (N3)  ---
Weighted undership % (WTUVS) (N3)  ---
Purchase Commodity
(CMDTY) (A5)                   -----
Purchase price (PURPR) (N15.4)    -----
Extended purchase item description
first 40 positions (PITDI) (A40)  -----
---
Extended purchase item description
last 40 positions (PITD2) (A40)  -----
---
Charge nature (CHGN) (A10)       -----
Pre-approved item code (A1)      -

```

*Indicates a required field.

**Use the appropriate transaction code for the type of maintenance you are going to perform.

Use form PM-28 to enter information for the Item Master C-record into an offline file.

Transaction code. A required code that indicates the type of offline maintenance being performed on this record.

E0IC0100 Add

E0IC0200 Change

E0IC0300 Delete

See “AMVT01—Item Master File Maintenance (Select)” and “AMVT05—Item Master File—Purchasing Information (Add/Change/Delete/Set Defaults)” for a description of the remaining fields on this form.

Labor/Overhead Table—Change Entry (PM-13)

Display AMVX71

- _ Product costing
- Simulation

Code (A1)	Labor rate (N8.3)	Code (A1)	Overhead rate/percent (N8.3) ±
-	-----	-	-----
-	-----	-	-----
-	-----	-	-----
-	-----	-	-----
-	-----	-	-----
-	-----	-	-----
-	-----	-	-----
-	-----	-	-----
-	-----	-	-----
-	-----	-	-----
-	-----	-	-----
-	-----	-	-----

For overhead:
 + indicates rate
 - indicates %

Note: Use A through Z or 0 through 9 as your code for either labor or overhead. Do not use duplicate labor codes or duplicate overhead codes. You can use up to 10 codes for labor and for overhead.

± = Write + or - in last position.

Use form PM-13 to change or simulate Labor/Overhead table values.

The fields on this form are described under display AMVX71. See "AMVX71—Labor/Overhead Table (Change)".

On form PM-16, valid codes are A through Z and 0 through 9. You can establish up to ten labor rate codes and ten labor overhead rates or percentages. Each code must be unique. Each labor rate and labor overhead rate or percentage must be unique. However, a labor code can be a duplicate of a labor overhead code. To indicate a labor overhead rate, make it positive (use **FIELD EXIT** or **FIELD +**). To indicate a labor overhead percentage, make it negative (use **FIELD -**).

This table is used only when you are using product costing and have items using cost technique code T (see Chapter 2.).

Product Structure File Maintenance (PM-14)

- _ Add
- _ Change *(A1)
- _ Delete
- _ S.A.E.

Display AMEU12, AMEU13, AMEU15, AMEU31, AMEU32, AMEU33, AMEU34

Parent item number * (A15)	-----
New Parent item number * (SAE) (A15)	-----
User sequence (A4)	----
Component item number * (A15)	-----
Quantity of components per parent (N11.3)	-----
Effective date from (inclusive) (N6)	-----
Effective date to (exclusive) (N6)	-----
Operation sequence number where first used (A4)	----
Component lead time adjustment (N3.1)	-----
Feature or option code (A1)	-
Feature or option number (A2)	--
Feature/options planning factor (N5.4)	-----
Feature/options cost roll-up factor (N5.4)	-----

*Indicates a required field.

Use form PM-14 to maintain information in the Product Structure file.

For information about the fields on this form, see “AMEU12—Product Structure File Maintenance (Add/Review)”, “AMEU13—Product Structure File Maintenance (Change/Review)”, “AMEU15—Product Structure File Maintenance (Delete/Review)”, “AMEU31—Product Structure File Maintenance (SAE Header)”, “AMEU32—Product Structure File Maintenance (SAE Change)”, “AMEU33—Product Structure File Maintenance (SAE Delete)”, and “AMEU34—Product Structure File Maintenance (SAE Add)”.

Product Structure Offline Maintenance (PM-15)

```

Transaction Code * TRID (A8)                                EOPS0400, EOPS0500, EOPS0600, EOPS0700 **
DAE generated seq number (reserved) DAESQ (N9)            -----
MPOI generated seq number (reserved) MPOSQ (N9)          -----
Level of response flag (reserved) RSPFL (A1)             -
Parent item number * + PINBR (A15)                      -----
User sequence (USRSQ (A4))                               -----
Component item number * CINBR (A15)                    -----
Operation sequence number where first used OPWFU (A4)    -----
Component lead time adjustment LTADJ (N3.1)             -- . --
Feature/options planning factor FOPPF (N5.4)            - . -----
Feature/options cost roll-up factor FOPCF (N5.4)        - . -----
Effective date from (inclusive) EDATM (N6)              -----
Effective date to (exclusive) EDATO (N6)                -----
Feature/option code FOPCD (A1)                         -
Feature/option number FOPNO (A2)                       --
Quantity of components per parent * QTYPR (N11.3)       ----- . -----

```

* Indicates a required field.
+ Some fields are not required for all transaction codes. See Appendix B for which fields are required for each transaction code.
** Use the appropriate transaction code for the type of maintenance you are going to perform.

Use form PM-15 to enter product structure information into an offline file.

Transaction code. The transaction code indicates what type of offline maintenance is being performed on this record.

Code	Meaning
E0PS0400	Total structure delete
E0PS0500	Delete record
E0PS0600	Add record
E0PS0700	Change record

DAE generated sequence number (reserved). This field is reserved for use by the XA Plant Operations Interface. Do not use this field.

MPOI generated sequence number (reserved). This field is reserved for use by the XA Plant Operations Interface. Do not use this field.

Level of response flag (reserved). This field is reserved for use by the XA Plant Operations Interface. Do not use this field.

For information about the remaining fields on this form, see “AMEU12—Product Structure File Maintenance (Add/Review)”, “AMEU13—Product Structure File Maintenance (Change/Review)”, “AMEU15—Product Structure File Maintenance (Delete/Review)”, “AMEU31—Product Structure File Maintenance (SAE Header)”, “AMEU32—Product Structure File Maintenance (SAE Change)”, “AMEU33—Product Structure File Maintenance (SAE Delete)”, and “AMEU34—Product Structure File Maintenance (SAE Add)”.

Example of how to build a bill of material

Because the Product Structure file may be a difficult file to build, an example is shown here using the figure in Chapter 2 that explains features and options. For additional information, read Chapter 2 again.

You can build your bills of material in a sequence other than component item number if you choose the user sequence function during application tailoring.

If you choose to specify user sequence for your bills of material, you have these added capabilities:

- To put the same component in a bill of material more than once.
- To arrange the bill of material to print and appear in a sequence other than component item number order.

If you choose user-designated sequence, you can specify how the user sequence number is used in combination with the component item number. You can load the product structure records in either of two sequences, depending on which one you select: component item number or user sequence number.

In this report sample, the bill of material is ordered by component item number, and none of the components appear more than once. This is the most common way of structuring a bill of material.

WACCO INC.		SINGLE LEVEL BILL				DATE **/**/**	TIME 17.18.11	PAGE		
1	AMEF71									
PARENT ITEM NO.		DESCRIPTION BASE ASSEMBLY				QTY	1	ITEM TYPE 1		
LOW LEVEL 02		ENGR DRAW AX00420						UNIT MEAS EA		
27007-A1		STANDARD BATCH QUANTITY				1.000				
PLANNER 902										
LL	SEQ	COMPONENT	DESCRIPTION	ENGINEERING	QUANTITY	ITEM	OPT	FIRST	LT	
EFFECTIVE DATES										
CD	NO.	ITEM NO.	TRUNCATED	DRAWING NUMBER	PER	UM	TYP NO.	OP	SEQ	ADJ
FROM	TO									
03		03416	BOLT 1/4 BY 1		2.000	EA	4		0010	
03		03417	BOLT 1/2 BY 2		2.000	EA	4		0010	
04		04632	WASHER		4.000	EA	4		0010	
03		27004-01	HANDLE	F8300006	1.000	EA	2		0010	
03		27007-20	FRAME	PX00440	1.000	EA	2		0010	
03		78053	WHEEL NUT		2.000	EA	4		0010	
03		86813	NUT		2.000	EA	4		0010	
03		89182	HANDLE SCREW		2.000	EA	4		0010	
03		98908	WASHER		2.000	EA	4		0010	

In this report sample, the bill of material is ordered by user sequence number. Component item 03416 appears more than once and these multiple occurrences are not in adjacent positions.

WACCO INC.		SINGLE LEVEL BILL				DATE **/**/**	TIME 17.36.36	PAGE	
1	AMEF71								
PARENT ITEM NO.		DESCRIPTION BASE ASSEPMBLY				QTY	1	ITEM TYPE 1	
LOW LEVEL 02		ENGR DRAW AX00420						UNIT MEAS EA	
27007-A1									
PLANNER 902		STANDARD BATCH QUANTITY				1.000			
LL SEQ	COMPONENT	DESCRIPTION	ENGINEERING	QUANTITY	ITEM	OPT	FIRST	LT	
EFFECTIVE DATES									
CD NO.	ITEM NO.	TRUNCATED	DRAWING NUMBER	PER	UM TYP	NO.	OP SEQ	ADJ	
FROM	TO								
03 10	03416	BOLT 1/4 BY 1		1.000	EA 4		0010		
03 15	86813	NUT		1.000	EA 4				
03 20	03417	BOLT 1/2 BY 2		2.000	EA 4		0010		
04 30	04632	WASHER		4.000	EA 4		0010		
03 40	27004-01	HANDLE	F8300006	1.000	EA 2		0010		
03 50	03416	BOLT 1/4 BY 1		1.000	EA 4				
03 60	86813	NUT		1.000	EA 4				
03 70	27007-20	FRAME	PX00440	1.000	EA 2		0010		
03 80	78053	WHEEL NUT		2.000	EA 4		0010		
03 100	89182	HANDLE SCREW		2.000	EA 4		0010		
03 110	98908	WASHER		2.000	EA 4	4		0010	

With the user sequence function, you can arrange bills of material with components in any order: ascending, descending, or random. Thus, you can place items in the bill of material in the following arrangements:

- Order of use in entire assembly
- Order of use by operation within assembly
- Order by feature number.

You may find the user sequence function useful in structuring features and options.

When retrieving feature bills of material structured in component item order, the order is probably not in feature number order. An example follows.

WACCO INC.		SINGLE LEVEL BILL				DATE **/**/**	TIME 17.17.35	PAGE	
1	AMEF71								
PARENT ITEM NO.		DESCRIPTION SPRAY UNIT				QTY	1	ITEM TYPE 1	
LOW LEVEL 00		ENGR DRAW						UNIT MEAS EA	
99001									
PLANNER 901		S-NO. **/**/**/**/**/**/**/**/**/**/							
		STANDARD BATCH QUANTITY				1.000			
LL SEQ	COMPONENT	DESCRIPTION	ENGINEERING	QUANTITY	ITEM	OPT	FIRST	LT	
EFFECTIVE DATES									
CD NO.	ITEM NO.	TRUNCATED	DRAWING NUMBER	PER	UM TYP	NO.	OP SEQ	ADJ	
FROM	TO								
01	03590-F3	SWITCH FEATURE	FEATURE 3	NON-REQD	F				
02	03590	AUTO SWITCH		1.000	EA 4	01			
01	03591-F1	WHEEL FEATURE	FEATURE 1	REQUIRED	F				
02	03591-08	WHEEL 8 IN DIA		2.000	EA 4	01			
02	03591-10	WHEEL 12 IN DIA		2.000	EA 4	02			
02	03591-12	WHEEL 18 IN DIA		2.000	EA 4	0A			
01	27006-F2	TANK SIZE FEATURE	FEATURE 2	REQUIRED	F		0010		
02	26006-20	TANK 8 BY 12 INCHES	A8300004	1.000	EA 1	01			
02	26006-21	TANK 10 BY 18 INCHES	A8400004	1.000	EA 1	02			
02	26006-22	TANK 12 BY 24 INCHES	A8500004	1.000	EA 1	03			
01	27009-P	FINAL ASSEMBLY GROUP		1.000	EA 0				
02	03021	VALVE		1.000	EA 4		0010		
02	03385	WRENCH		1.000	EA 4		0010		
02	03398	CORD BRACKET		1.000	EA 4	4		0010	

You can use the user sequence number to structure the bill of material so that the order is in feature-and-option-number order, as shown in the example that follows.

WACCO INC.		SINGLE LEVEL BILL		DATE **/**/**		TIME 17.52.13		PAGE	
1	AMEF71								
PARENT ITEM NO.		DESCRIPTION SPRAY UNIT		QTY		1		ITEM TYPE 1	
LOW LEVEL 00		ENGR DRAW						UNIT MEAS EA	
99001									
PLANNER 901									
		S-NO. **/**/**/**/**/**/**/**/**/**/**							
		STANDARD BATCH QUANTITY		1.000					
LL SEQ	COMPONENT	DESCRIPTION	ENGINEERING	QUANTITY	ITEM	OPT	FIRST	LT	
EFFECTIVE DATES	CD NO.	TRUNCATED	DRAWING NUMBER	PER	UM TYP	NO.	OP SEQ	ADJ	
FROM	TO								
01 10	03591-F1	WHEEL FEATURE	FEATURE 1	REQUIRED	F				
02 1	03591-08	WHEEL 8 IN DIA		2.000	EA 4	01			
02 2	03591-10	WHEEL 12 IN DIA		2.000	EA 4	02			
02 3	03591-12	WHEEL 18 IN DIA		2.000	EA 4	0A			
01 20	27006-F2	TANK SIZE FEATURE	FEATURE 2	REQUIRED	F		0010		
02 1	26006-20	TANK 8 BY 12 INCHES	A8300004	1.000	EA 1	01			
02 2	26006-21	TANK 10 BY 18 INCHES	A8400004	1.000	EA 1	02			
02 3	26006-22	TANK 12 BY 24 INCHES	A8500004	1.000	EA 1	03			
01 30	03590-F3	SWITCH FEATURE	FEATURE 3	NON-REQD	F				
02 1	03590	AUTO SWITCH		1.000	EA 4	01			
01 90	27009-P	FINAL ASSEMBLY GROUP		1.000	EA 0				
02	03021	VALVE		1.000	EA 4		0010		
02	03385	WRENCH		1.000	EA 4		0010		
02	03398	CORD BRACKET		1.000	EA 4			0010	

The spray unit shown in Figure 9-1 has four components in the first level down from the end item level. The first component, wheel size feature 1, is a required feature. The second component, tank size feature 2, is also a required feature. The third component, switch feature 3, is a nonrequired feature. The last component, for purposes of discussion here, is considered a phantom. Counting the links to the end item, you find eleven links: four at the first level and seven at the second. To represent the level relationships, you would make up eleven product structure records. Follow the forms as shown in 9-2 through 9-7 .

Note: Items that are features or phantoms must be coded as such in the Item Master file.

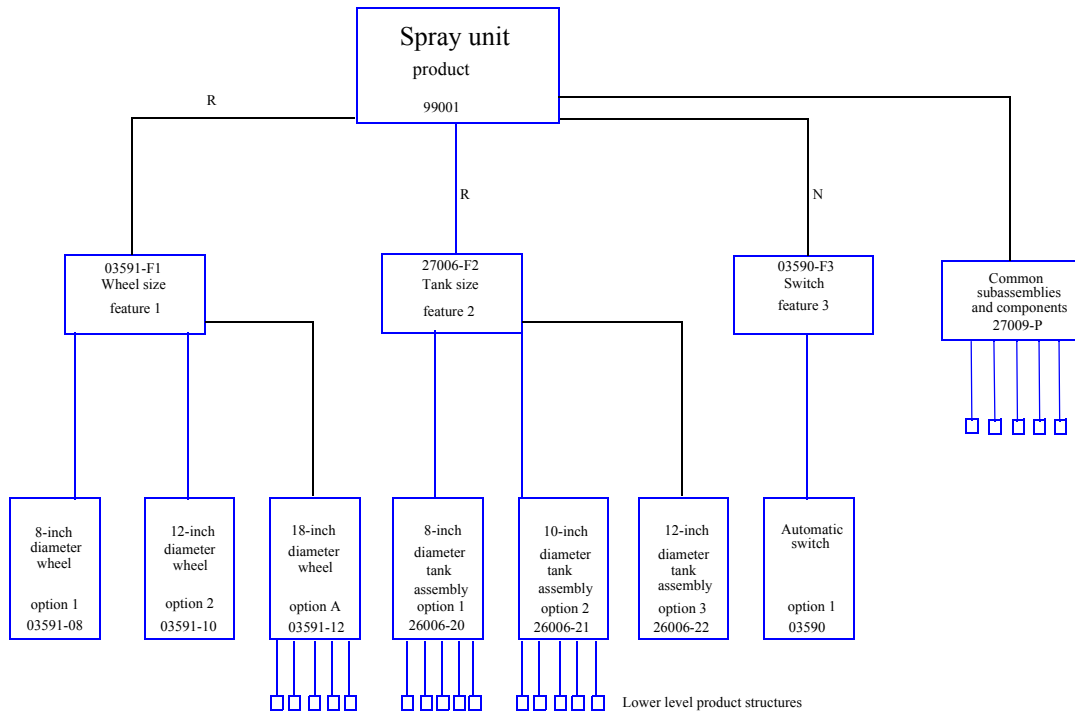

Figure 9-1. A spray unit with features and options

Wheel size feature

Product Structure File Maintenance		PM-14
Display AMEU12, AMEU13, AMEU31, AMEU32, AMEU34		Add (A1) <input checked="" type="checkbox"/>
		Change (A1) <input type="checkbox"/>
		S.A.E. (A1) <input type="checkbox"/>
* Parent item number (A15)	<u>99001</u> -----	
* New Parent item number (SAE) (A15)	-----	
User Sequence (A4)	<u>0010</u>	
* Component item number (A15)	<u>03591-F1</u> -----	
Quantity of components per parent (N11.3)	----- <u>10.00</u>	
Effective date from (inclusive) (N6)	-----	
Effective date to (exclusive) (N6)	-----	
Operation sequence number where first used (A4)	----	
Component lead time adjustment (N3.1)	---	
Feature or option code (A1)	<u>R</u> (Required)	
Feature or option number (A2)	<u>01</u>	
Feature/options planning factor (N5.4)	-----	
Feature/options cost roll-up factor (N5.4)	-----	
* Indicates a required field		

8-inch wheel option

Product Structure File Maintenance		PM-14
Display AMEU12, AMEU13, AMEU31, AMEU32, AMEU34		Add (A1) <input checked="" type="checkbox"/>
		Change (A1) <input type="checkbox"/>
		S.A.E. (A1) <input type="checkbox"/>
* Parent item number (A15)	<u>03591-F1</u> -----	
* New Parent item number (SAE) (A15)	-----	
User Sequence (A4)	<u>0001</u>	
* Component item number (A15)	<u>03591-08</u> -----	
Quantity of components per parent (N11.3)	----- <u>20.00</u>	
Effective date from (inclusive) (N6)	-----	
Effective date to (exclusive) (N6)	-----	
Operation sequence number where first used (A4)	----	
Component lead time adjustment (N3.1)	---	
Feature or option code (A1)	<u>O</u> (Option)	
Feature or option number (A2)	<u>01</u>	
Feature/options planning factor (N5.4)	-----	
Feature/options cost roll-up factor (N5.4)	-----	
* Indicates a required field		

Figure 9-2. Product structures for wheel size, first feature (required) of the spray unit

12-inch wheel option

Product Structure File Maintenance		PM-14
Display AMEU12, AMEU13, AMEU31, AMEU32, AMEU34		Add (A1) <input checked="" type="checkbox"/>
		Change (A1) <input type="checkbox"/>
		S.A.E. (A1) <input type="checkbox"/>
* Parent item number (A15)	<u>03591-F1</u> -----	
* New Parent item number (SAE) (A15)	-----	
User Sequence (A4)	<u>0002</u>	
* Component item number (A15)	<u>03591-10</u> -----	
Quantity of components per parent (N11.3)	----- <u>2.000</u>	
Effective date from (inclusive) (N6)	-----	
Effective date to (exclusive) (N6)	-----	
Operation sequence number where first used (A4)	----	
Component lead time adjustment (N3.1)	-. .-	
Feature or option code (A1)	<u>Q</u> (Option)	
Feature or option number (A2)	<u>02</u>	
Feature/options planning factor (N5.4)	-. ----	
Feature/options cost roll-up factor (N5.4)	-. ----	
* Indicates a required field		

18-inch wheel option

Product Structure File Maintenance		PM-14
Display AMEU12, AMEU13, AMEU31, AMEU32, AMEU34		Add (A1) <input checked="" type="checkbox"/>
		Change (A1) <input type="checkbox"/>
		S.A.E. (A1) <input type="checkbox"/>
* Parent item number (A15)	<u>03591-F1</u> -----	
* New Parent item number (SAE) (A15)	-----	
User Sequence (A4)	<u>0003</u>	
* Component item number (A15)	<u>03591-12</u> -----	
Quantity of components per parent (N11.3)	----- <u>2.000</u>	
Effective date from (inclusive) (N6)	-----	
Effective date to (exclusive) (N6)	-----	
Operation sequence number where first used (A4)	----	
Component lead time adjustment (N3.1)	-. .-	
Feature or option code (A1)	<u>Q</u> (Option)	
Feature or option number (A2)	<u>0A</u>	
Feature/options planning factor (N5.4)	-. ----	
Feature/options cost roll-up factor (N5.4)	-. ----	
* Indicates a required field		

Figure 9-3. Product structures of two other options of first feature of the spray unit

Tank size feature

Product Structure File Maintenance		PM-14
Display AMEU12, AMEU13, AMEU31, AMEU32, AMEU34		Add (A1) <input checked="" type="checkbox"/>
		Change (A1) <input type="checkbox"/>
		S.A.E. (A1) <input type="checkbox"/>
* Parent item number (A15)	<u>99001</u> -----	
* New Parent item number (SAE) (A15)	-----	
User Sequence (A4)	<u>0026</u>	
* Component item number (A15)	<u>27006-F2</u> -----	
Quantity of components per parent (N11.3)	----- <u>1.000</u>	
Effective date from (inclusive) (N6)	-----	
Effective date to (exclusive) (N6)	-----	
Operation sequence number where first used (A4)	----	
Component lead time adjustment (N3.1)	---	
Feature or option code (A1)	<u>R</u> (Required)	
Feature or option number (A2)	<u>02</u>	
Feature/options planning factor (N5.4)	-----	
Feature/options cost roll-up factor (N5.4)	-----	
* Indicates a required field		

8-inch tank option

Product Structure File Maintenance		PM-14
Display AMEU12, AMEU13, AMEU31, AMEU32, AMEU34		Add (A1) <input checked="" type="checkbox"/>
		Change (A1) <input type="checkbox"/>
		S.A.E. (A1) <input type="checkbox"/>
* Parent item number (A15)	<u>27006-F2</u> -----	
* New Parent item number (SAE) (A15)	-----	
User Sequence (A4)	<u>0001</u>	
* Component item number (A15)	<u>27006-20</u> -----	
Quantity of components per parent (N11.3)	----- <u>1.000</u>	
Effective date from (inclusive) (N6)	-----	
Effective date to (exclusive) (N6)	-----	
Operation sequence number where first used (A4)	----	
Component lead time adjustment (N3.1)	---	
Feature or option code (A1)	<u>O</u> (Option)	
Feature or option number (A2)	<u>01</u>	
Feature/options planning factor (N5.4)	-----	
Feature/options cost roll-up factor (N5.4)	-----	
* Indicates a required field		

Figure 9-4. Product structures for tank size and one option of second feature (required) of the spray unit

10-inch tank option

Product Structure File Maintenance		PM-14
Display AMEU12, AMEU13, AMEU31, AMEU32, AMEU34	Add (A1)	<input checked="" type="checkbox"/>
	Change (A1)	<input type="checkbox"/>
	S.A.E. (A1)	<input type="checkbox"/>
* Parent item number (A15)	<u>27006-F2</u>	-----
* New Parent item number (SAE) (A15)	-----	-----
User Sequence (A4)	<u>0002</u>	
* Component item number (A15)	<u>26006-21</u>	-----
Quantity of components per parent (N11.3)	-----	<u>1.000</u>
Effective date from (inclusive) (N6)	-----	
Effective date to (exclusive) (N6)	-----	
Operation sequence number where first used (A4)	-----	
Component lead time adjustment (N3.1)	-----	
Feature or option code (A1)	<u>0</u> (Option)	
Feature or option number (A2)	<u>02</u>	
Feature/options planning factor (N5.4)	-----	
Feature/options cost roll-up factor (N5.4)	-----	
*Indicates a required field		

12-inch tank option

Product Structure File Maintenance		PM-14
Display AMEU12, AMEU13, AMEU31, AMEU32, AMEU34	Add (A1)	<input checked="" type="checkbox"/>
	Change (A1)	<input type="checkbox"/>
	S.A.E. (A1)	<input type="checkbox"/>
* Parent item number (A15)	<u>27006-F2</u>	-----
* New Parent item number (SAE) (A15)	-----	-----
User Sequence (A4)	<u>0003</u>	
* Component item number (A15)	<u>26006-22</u>	-----
Quantity of components per parent (N11.3)	-----	<u>1.000</u>
Effective date from (inclusive) (N6)	-----	
Effective date to (exclusive) (N6)	-----	
Operation sequence number where first used (A4)	-----	
Component lead time adjustment (N3.1)	-----	
Feature or option code (A1)	<u>0</u> (Option)	
Feature or option number (A2)	<u>03</u>	
Feature/options planning factor (N5.4)	-----	
Feature/options cost roll-up factor (N5.4)	-----	
*Indicates a required field		

Figure 9-5. Product structures of two other options of second feature of the spray unit

Switch feature

Product Structure File Maintenance		PM-14
Display AMEU12, AMEU13, AMEU31, AMEU32, AMEU34		Add (A1) <input checked="" type="checkbox"/>
		Change (A1) <input type="checkbox"/>
		S.A.E. (A1) <input type="checkbox"/>
*Parent item number (A15)	<u>9901</u> -----	
*New Parent item number (SAE) (A15)	-----	
User Sequence (A4)	<u>0030</u>	
*Component item number (A15)	<u>03590-F3</u> -----	
Quantity of components per parent (N11.3)	----- <u>1.000</u>	
Effective date from (inclusive) (N6)	-----	
Effective date to (exclusive) (N6)	-----	
Operation sequence number where first used (A4)	----	
Component lead time adjustment (N3.1)	---	
Feature or option code (A1)	<u>N</u> (Not required)	
Feature or option number (A2)	<u>03</u>	
Feature/options planning factor (N5.4)	-----	
Feature/options cost roll-up factor (N5.4)	-----	
* Indicates a required field		

Automatic switch option

Product Structure File Maintenance		PM-14
Display AMEU12, AMEU13, AMEU31, AMEU32, AMEU34		Add (A1) <input checked="" type="checkbox"/>
		Change (A1) <input type="checkbox"/>
		S.A.E. (A1) <input type="checkbox"/>
*Parent item number (A15)	<u>03590-F3</u> -----	
*New Parent item number (SAE) (A15)	-----	
User Sequence (A4)	<u>0001</u>	
*Component item number (A15)	<u>03590</u> -----	
Quantity of components per parent (N11.3)	----- <u>1.000</u>	
Effective date from (inclusive) (N6)	-----	
Effective date to (exclusive) (N6)	-----	
Operation sequence number where first used (A4)	----	
Component lead time adjustment (N3.1)	---	
Feature or option code (A1)	<u>O</u> (Option)	
Feature or option number (A2)	<u>01</u>	
Feature/options planning factor (N5.4)	-----	
Feature/options cost roll-up factor (N5.4)	-----	
* Indicates a required field		

Figure 9-6. Product structures for switch, third feature (nonrequired) of the spray unit

Switch feature

Product Structure File Maintenance		PM-14
Display AMEU12, AMEU13, AMEU31, AMEU32, AMEU34		Add (A1) <input checked="" type="checkbox"/>
		Change (A1) <input type="checkbox"/>
		S.A.E. (A1) <input type="checkbox"/>
* Parent item number (A15)	<u>99001</u> -----	
* New Parent item number (SAE) (A15)	-----	
User Sequence (A4)	<u>0090</u>	
* Component item number (A15)	<u>27009 - P</u> -----	
Quantity of components per parent (N11.3)	----- <u>1.000</u>	
Effective date from (inclusive) (N6)	-----	
Effective date to (exclusive) (N6)	-----	
Operation sequence number where first used (A4)	-----] <i>Must be blank</i>
Component lead time adjustment (N3.1)	-----	
Feature or option code (A1)	-	
Feature or option number (A2)	--	
Feature/options planning factor (N5.4)	-.-----	
Feature/options cost roll-up factor (N5.4)	-.-----	
* Indicates a required field		

Figure 9-7. Product structure for the phantom in the spray unit

The examples in the previous figures show only a few ways to build a bill of material. You do not have to structure your bills of material in the same way.

While you might select the user sequence function at application tailoring, you do not have to use this capability for all your bills of material. If you do not enter data in the user sequence field, this field remains blank in the product structure records and the retrieval of the bill of material appears in component item order.

Use form PM-16 to change or simulate Purchase Overhead table values.

The fields on this form are described under display AMVX72. See “AMVX72—Purchase Overhead Table (Change)”.

On form PM-16, valid codes are A through Z and 0 through 9. You can establish up to twenty codes and twenty purchase overhead percentages. Each code must be unique. Each percentage must be unique.

Use this form only when you are using product costing and have item type 3 or 4 with an entry in the Purchase overhead table code. Cost technique code T has no effect in the calculation of Purchase Overhead.

Routing File Maintenance (PM-17)

Display AMEU71, AMEU72, AMEU73, AME721, AME722, AMEU24

- Add
- Change * (A1)
- Delete
- S.A.E.

Parent item number * (A15)	-----
New parent item number * (SAE) (A15)	-----
Operation sequence number * (A4)	----
Operation description (A20)	-----
Facility ID * (A5)	-----
Time basis code (TBC) (A1)	-
Outside cost (N19.8)	-----
Print flag (A1)	-
Run machine (used with TBC) (N5.2)	-----
Setup labor time (N5.2)	-----
Report point (N1)	-
Run labor (used with TBC) (N5.2)	-----
Set crew size (N2)	--
Operation run quantity (N7.3)	-----
Move time in days (N4.2)	-----
Operation status code (N2)	--
Tool number (A6)	-----
Standard operation yield (N4.3)	-----
Process sheet number (A6)	-----
Current operation yield (N4.3)	-----
Inventory transaction code (A2)	--
Select code (A2)	--

* Indicates a required field.

Use form PM-17 to maintain records in the Routing file.

Note: You cannot use the Routing file unless you specifically ask for it during application tailoring, or unless PC&C is installed and interfacing.

For information about the fields on this form, see “AMEU71—Routing File Maintenance (Select)”, AMVT72—Production Facility Maintenance (Change), “AMEU73—Routing File Maintenance (Change/Review)”, “AMEU21—Routing File Maintenance (SAE Header)”, “AMEU22—Routing File Maintenance (SAE Change)”, and “AMEU24—Routing File Maintenance (SAE Add)”.

If you want to add or change additional routing descriptions for this operation, use the Routing Description File Maintenance, Additional Descriptions form (PM-21).

Routing File Milestone Group Maintenance (PM-18)

Display AMEU79, AMEU28

Item number (A15)		-----		
Action	Beginning		Ending	Milestone
code *	operation *		operation **	type **
(ACTCD)	(BEGOP)		(ENDOP)	(MSTYP)
(A1)	(A4)		(A4)	(A1)
-	----		----	-
-	----		----	-
-	----		----	-
-	----		----	-
-	----		----	-
-	----		----	-
-	----		----	-
-	----		----	-
-	----		----	-
-	----		----	-
-	----		----	-
-	----		----	-

*Indicates a required field for Define or Remove milestone.

**Indicates a required field for Define milestone only.

Use form PM-18 to maintain routing milestone group records in the Routing file.

The fields on this form are described under displays AMEU79 and AMEU28. See “AMEU79—Routing File Maintenance (MS-MAINT)” and “AMEU28—Routing File Maintenance (SAE MS-MNT)”.

Use form PM-21 to maintain additional routing description records in the Routing Description file.

The fields on this form are described under displays AMEU78 and AMEU27. See “AMEU78—Routing File Maintenance (Update)” and “AMEU27—Routing File Maintenance (SAE Addl Desc Maint)”.

Routing File Offline Maintenance (PM-29)

Transaction Code *	EORT0500, EORT0800, EORT0900, EORT1000 **		
	EORT1100, EORT1800, EORT1900		
	EORT2000, EORT2100, EORT3000		
TRID (A8)	-----		
DAE generated seq number (reserved) DAESQ (N9)	-----		
MPOI generated seq number (reserved) MPOSQ (N9)	-----		
Level of response flag (reserved) RSPFL (A1)	_		
Item number * + ITNBR (A15)	-----		
Operation sequence number * OPSEQ (A4)	-----	Current operation yield CYTOP (N4.3)	_. _ _ _
Production facility ID * WKCTR (A5)	-----	Transaction code TCODE (A2)	_ _
Run machine time (use TBC) RUNMC (N5.2)	----- . _ _	Select number SELNO (A2)	_ _
Run labor time (use TBC) RUNLB (N5.2)	----- . _ _	Routing print flag PRTFG (A1)	_
Setup labor hours SULHR (N5.2)	----- . _ _	Report code IRCOD (N1)	_
Setup crew size SUCSZ (N2)	-----	Operation run quantity PUNIT (N7.3)	-----
Time basis code TBCOD (A1)	-----	Operation description line sequence number * DSQNO (N3)	-----
	Operation description (OPDSC) (A20)		Additional operation description
ADDSC (A40)	-----		-----
Move time (in days) MOTVM (N4.2)	----- . _ _	Beginning operation * BEGOP (A4)	-----
Tool number RTOOL (A6)	-----	Ending Operation * ENDOP (A\$)	-----
Process sheet number PRONO (A6)	-----	Milestone type * MSTYP (A1)	_
Operation status code OPSTC (A2)	-----	Outside cost (OSCS) (N19.8)	-----
Standard operation yield SYTOP (N4.3)	----- . _ _ _	Old operation sequence number OLSEQ (A4)	-----

* Indicates a required field.

+ Some fields are not required for all transaction codes. See [Appendix B](#) for which fields are required for each transaction code.

** Use the appropriate transaction code for the type of maintenance you are going to perform.

Use form PM-29 to enter routing information into an offline file.

Transaction code. The transaction code indicates what type of offline maintenance is being performed on this record.

E0RT0500	Milestone delete
E0RT0800	Total routing delete
E0RT0900	Delete record
E0RT1000	Add record
E0RT1100	Change record
E0RT1800	Additional description multiple delete
E0RT1900	Additional description delete
E0RT2000	Additional description add
E0RT2100	Additional description change
E0RT3000	Milestone define

DAE generated sequence number (reserved). This field is reserved for use by the XA Plant Operations Interface. Do not use this field.

MPOI generated sequence number (reserved). This field is reserved for use by the XA Plant Operations Interface. Do not use this field.

Level of response flag (reserved). This field is reserved for use by the XA Plant Operations Interface. Do not use this field.

For information about the remaining fields on this form, see “AMEU71—Routing File Maintenance (Select)”, “AMEU72—Routing File Maintenance (Add/Review)”, “AMEU73—Routing File Maintenance (Change/Review)”, “AMEU21—Routing File Maintenance (SAE Header)”, “AMEU22—Routing File Maintenance (SAE Change)”, and “AMEU24—Routing File Maintenance (SAE Add)”.

Production Facility Maintenance (PM-23)

Display AMVT71, AMVT72, AMVT73	Add _	Change _	Delete _
Facility ID (A5)	---		
Facility type (A1)	-		
Description (required) (A40)	-----		
Department (A4)	----		
Production facility accounting class (A3)	---		
Queue time-days (N4.2)	-- . --		
Foreman (A3)	---		
Prime load code (A1)	-		
Average queue time (N7.2)	-- . --		
Location (A5)	-----		
Tracking signal (N7.2)	-- . --		
Queue MAD (7.2)	-- . --		
Standard efficiency (N3.2)	. --		
Average standard output (N7.2)	-- . --		
Machine resource number (A5)	-----		
Average efficiency (N3.2)	. --		
Average actual output (N7.2)	-- . --		
Labor resource number (A5)	-----		
Extract machine breaks * (A1)	-		
Reporting method (A1)	-		
Clocking window (N1:2)	- : --		
Current machine rate (N8.3)	-- . --		
Current run labor rate (N8.3)	-- . --		
Current setup labor rate (N8.3)	-- . --		
Current labor overhead rate/percentage (N8.3)	-- . --		
Current labor overhead code (A1)	-		
Standard machine rate (N8.3)	-- . --		
Standard run labor rate (N8.3)	-- . --		
Standard setup labor rate (N8.3)	-- . --		
Standard labor overhead rate/percentage (N8.3)	-- . --		
Standard labor overhead code (A1)	-		
	Desired length	Maximum length	Desired capacity
ity			Maximum capac
Shift 1 (N3.1)	-- . --	-- . --	-- . --
Shift 2 (N3.1)	-- . --	-- . --	-- . --
Shift 3 (M3.1)	-- . --	-- . --	-- . --
Calendar ID (A10)	-----		
Post to oldest schedule (A1)	-		
Post to future schedule (A1)	-		
Facility stock location (A7)	-----		

Use form PM-23 to maintain production facility records in the Production Facility file.

See the following for a description of the fields on this form:

- “AMVT72—Production Facility Maintenance (Change)”
- “AMVT73—Production Facility Maintenance (Delete)”

Production Facility Offline Maintenance (PM-30A)

Transaction code *	Add	EOPF0100
	Change	EOPF0200
	Delete	EOPF0300 **
TRID (A8)		-----
DAE generated seq number (reserved) DAESQ (N9)		-----
MPOI generated seq number (reserved) MPOSQ (N9)		-----
Level of response flag (reserved) RSPFL (A1)		-
Production facility ID * + WKCTR (A5)		-----
Production facility type WLNC (A1)		-
Production facility description * WCDSC (A40)		-----

Department number DPTNO (A4)		-----
Queue time (days) STDQT (N4.2)		-.---
Average queue time AVGQT (N7.2)		----- .---
Foreman FRMAN (A3)		---
Prime load code PLOAD (A1)		-
Queue mad WQMAD (N7.2)		----- .---
Production facility location WCLOC (A5)		-----
Tracking signal TRSIG (N7.2)		----- .---
Standard efficiency STDEF (N3.2)		-.---
Average standard output AVGS (N7.2)		----- .---
Machine resource number MACRN (A5)		-----
Average efficiency AVGEF (N3.2)		-.---
Average actual output AVGAO (N7.2)		----- .---
Labor resource number LABRN (A5)		-----

* Indicates a required field.
 + Some fields are not required for all transaction codes. See [Appendix B](#) for each transaction code.
 ** Use the appropriate transaction code for the type of maintenance you are going to perform.

Production Facility Offline Maintenance (PM-30B)

Extract machine breaks * BRKXT (A1)	-
Current machine rate CMACH (N8.3)	----- . ----
Current run labor rate CRLAB (N8.3)	----- . ----
Current setup labor rate CSLAB (N8.3)	----- . ----
Current labor overhead rate/percent COVER (N8.3)	----- . ----
Current labor overhead code COCOD (A1)	-
Standard machine rate SMACH (N8.3)	----- . ----
Standard run labor rate SRLAB (N8.3)	----- . ----
Standard setup labor rate SSLAB (N8.3)	----- . ----
Standard labor overhead rate/percentage SOVER (N8.3)	----- . ----
Standard labor overhead code SOCOD (A1)	-
Desired shift length 1 DLEN1 (N3.1)	--- . --
Maximum shift length 1 MLEN1 (N3.1)	--- . --
Desired capacity 1 DCAP1 (N3.1)	--- . --
Maximum capacity 1 MCAP1 (N3.1)	--- . --
Desired shift length 2 DLEN2 (N3.1)	--- . --
Maximum shift length 2 MLEN2 (N3.1)	--- . --
Desired capacity 2 DCAP2 (N3.1)	--- . --
Maximum capacity 2 MCAP2 (N3.1)	--- . --
Desired shift length 3 DLEN3 (N3.1)	--- . --
Maximum shift length 3 MLEN3 (N3.1)	--- . --
Desired capacity 3 DCAP3 (N3.1)	--- . --
Maximum capacity 3 MCAP3 (N3.1)	--- . --
Production facility accounting code PFAC (A3)	---
Reporting method RPMD (N1)	-
Clocking window CLWD (N3.2)	--- . --
Production calendar (A10)	-----
Bitmap identifier	-----
Post to oldest schedules APSQ (A1)	-
Post to future schedules APTQ (A1)	-
Facility stocking location (A7)	-----

Use forms PM-30A and PM-30B to enter information for a production facility into an offline file.

Transaction code. The transaction code indicates what type of offline maintenance is being performed on this record.

E0PF0100 Add
E0PF0200 Change
E0PF0300 Delete

DAE generated sequence number (reserved). This field is reserved for use by the XA Plant Operations Interface. Do not use this field.

MPOI generated sequence number (reserved). This field is reserved for use by the XA Plant Operations Interface. Do not use this field.

Level of response flag (reserved). This field is reserved for use by the XA Plant Operations Interface. Do not use this field.

See "AMVT71--Production Facility Maintenance (Add)" for descriptions of fields.

Variable Capacity Master File Maintenance (TM-01)

- _ 1. Add * (A1)
- _ 2. Change
- _ 3. Delete
- _ 4. Delete all

Displays AMVTC1, AMVTC2, AMVTC3, AMVTC4, AMVTC5

```

I Site (A3) *           _ _ _
Facility ID * (A5)     _ _ _ _ _
Description (A40)      _ _ _ _ _
Start date * (N6)     _ _ _ _ _
Number of days * (N2)  _ _
New shift length:
  Shift 1 (N3.1)       _ _ . _
  Shift 2 (N3.1)       _ _ . _
  Shift 3 (N3.1)       _ _ . _
Incremental resources:
  Shift 1 (N3.1)       _ _ . _ +/-
  Shift 2 (N3.1)       _ _ . _ +/-
  Shift 3 (N3.1)       _ _ . _ +/-
Source description (N25) _ _ _ _ _
  
```

*Indicates a required field

+/- Indicates these fields are signed fields; you must show in the last position whether the value entered is to be added or subtracted from the base capacity.

Use form TM-01 to add, change, or delete variable capacity information.

Add/Change/Delete. A required field that indicates the maintenance function you want to perform.

See “AMVTC1—Variable Capacity Maintenance (Select)”, “AMVTC2—Variable Capacity Maintenance (Add)”, and “AMVTC3—Variable Capacity Maintenance (Change)” for a description of the fields on this form.

Chapter 10. Accounting controls and audits

The controls reports shown in this chapter are used to make sure the records you have loaded, unloaded, reloaded, or reorganized match with what was expected. All the controls reports in PDM deal with the number of records added, changed, or deleted. By checking these reports, you can make sure that the files you loaded were loaded in their entirety and that the transactions you applied to them were processed.

Item Master edit/load

The Item Master Offline Maintenance Edit list (AMEK1) is printed when you select ERRORS ONLY LISTING on display AXVOL1. A transaction detail is printed above the Item Master Statistics for any transaction that has been rejected. The Item Master Offline Maintenance Audit List (AMKE3) is printed when you choose edit with load. This reports shows all the records loaded and the records that had errors and were rejected.

The update number on reports AMKE1 and AMKE3 should match.

```

NORTHCREEK IND.          ITEM MASTER OFFLINE MAINTENANCE EDIT LIST          DATE 9/07/
** TIME 12.35.51 PAGE 1 AMKE1
                                                                    UPDATE# 262
-----
GENERAL INFORMATION (CHANGE)
ITEM NUMBER AMTPF0218          DESCRIPTION 18 CU FT AMAXZA TOP FREEZER
ITEM TYPE CODE 4 ENG DRW      DRW0112          QC CONTROL 0 ITEM PRICE CLASS          MASTER SCH
ED ITEM CODE
ITEM CLASS CI STD BCH QTY          1.000 SHELF LIFE          SALES TAX IND          T00 PROD FAM P
LANNER
VALUE CLASS
LOT CTL 0 COMMISSION PCT .000 DEMAND TIME FENCE
INVENTORY CODE 04 LOW LEVEL          2 INSP ON RECEIPT 0 PRICE U/
M RESOURCE NUMBER
DEPARTMENT REP3 STD TOT CUM YLD          1.000 DISCRETE ALLOC 0          RESOURCE B
UILD FLAG N
ITM ACTG CLS          CUR TOT CUM YLD          1.000 WARRANTY PER          UNIT WEIGHT          .000 TAX COMM C
ODE CARRYING RATE .000 AVG TOT CUM YLD          1.000 WARRANTY PER U/M          WEIGHT U/M          TAX WGHT/
UNIT .0000
COUNTRY OF ORIG          SINGLE LEVEL COMP'S          SERIAL NUM REQD 0 SPEC GRAVITY          .0000 ORDER U/
M CLASS
W/
H STK LOC          DIRECT USAGES          1 PRT ON SALES ANL 0 PACKING CODE          ITEM SALES GROUP
ABC
STOCKING U/M EA ROUTING OPERATIONS          KIT DOC PRINT OPT 0 BILL/LAD COM CD
STD SETUP COST/
LOT .00000000          SUPP WGHT          .0000 RECORD MAINTENANCE:
UNIT COST DEFAULT          314.00000000          VENDR PRIMARY          SUPP WGHT U/M          CREATED
BASE PRICE          .000          PUR TAX IND          TAX CLASS          CHANGED D
LHANSEN 09/01/**
BASE PRICE EFFECTIVE DATE          06/30/**
COSTING INFORMATION (CHANGE)
ITEM NUMBER AMTPF0218          RECOST FLAG C          UNIT COST          RECOST NEEDED
CUR UNIT COST          $312.50000000          CUR COST STATUS CD          CUM F/O COST ROLL FACT .0000
STD UNIT COST          $314.00000000          STD COST STATUS CD          LABOR HOURS          .0000
CUR SETUP COST/LOT          $.00000000          CST TECHNIQUE CODE Q          STD LOT SIZE          .000
-----CURRENT-----          LAST MAINT          TBL          -----THIS LEVEL-----          -----LOWER LEVELS-----
PURCHASE CONTENT          7/04/**          $312.56247183          $.00000000
PURCHASE OVERHEAD          $.00000000          $.00000000
OUTSIDE OPERATIONS          $.00000000
LABOR CONTENT          8/28/**          $.00000000          $.00000000
LABOR OVERHEAD          $.00000000          $.00000000
-----STANDARD-----          LAST MAINT          TBL          -----THIS LEVEL-----          -----LOWER LEVELS-----
PURCHASE CONTENT          8/28/**          $314.00000000          $.00000000
PURCHASE OVERHEAD          $.00000000          $.00000000
OUTSIDE OPERATIONS          $.00000000
LABOR CONTENT          8/28/**          $.00000000          $.00000000
LABOR OVERHEAD          $.00000000          $.00000000
E AM-4926 Inventory code not valid for item type
E AM-4909 PSTRUC RECORDS EXIST-CHANGE NOT ALLOWED
E AM-4626 COST TECHNIQUE CD MUST BE BLANK, T, OR R

```

```

NORTHCREEK IND.          ITEM MASTER OFFLINE MAINTENANCE EDIT LIST          DATE 9/07/
** TIME 12.35.51 PAGE 2 AMKE1
                                                                    UPDATE# 262
-----
I T E M M A S T E R S T A T I S T I C S
-----
REJECTED -----          ACCEPTED -----
ELETES          TOTAL          ADDS          CHANGES          DELETES          TOTAL          ADDS          CHANGES          D
0          1          ITEM MASTER 'A'          0          0          0          0          0          1
0          1          ITEM MASTER 'B'          0          0          0          0          0          1
0          0          ITEM MASTER 'C'          0          0          0          0          0          0

```

Product structure edit/load

The Product Structure Offline Maintenance Edit List (AMEB0) is printed when you choose edit or edit with load from the Master Menu. A transaction detail is printed above the P/S Edit Run Statistics for any transaction that has been rejected. The Product Structure Offline Maintenance Audit List (AMEB11) is printed when you choose edit with load. These reports are printed when you make these selections.

The following numbers on reports AMEB0 and AMEB3 should match:

- Update number
- Accepted transactions on the transaction edit list and the total transactions on the load list.

```

NORTHCREEK IND.          PRODUCT STRUCTURE OFFLINE MAINTENANCE EDIT LIST      DATE 8/29/
** TIME 16.08.52  PAGE   1  AMEB0                                          UPDATE#  2

-----P/S EDIT RUN STATISTICS-----
-----ADD TRANSACTIONS-----
ACCEPTED  NOT ACCEPTED  TOTAL  QUANTITY TOTAL
    174             0         174      350.000
-----CHANGE TRANSACTIONS-----
ACCEPTED  NOT ACCEPTED  TOTAL  QUANTITY TOTAL
     0             0         0         0
-----DELETE TRANSACTIONS-----
ACCEPTED  NOT ACCEPTED  TOTAL  QUANTITY TOTAL
     0             0         0         0
-----INVALID TRANSACTION CODES-----
TOTAL
    
```

```

NORTHCREEK IND.          PRODUCT STRUCTURE OFFLINE MAINTENANCE AUDIT LIST      DATE 8/29/
** TIME 16.42.05  PAGE   1  AMEB11                                          UPDATE#  2

PARENT 03424
LL E SEQ COMPONENT      DESCRIPTION-TRUNCATED      LLC          STANDARD BATCH QUANTITY
O PLANNING COST ROLL BATCH ACTION  QUANTITY  EFFECTIVE DATES FIRST LT F/
CD  NO. ITEM NO.        PER        FROM        TO OPER ADJ      FACTOR  FACTOR
    1
    0000 03421          1.000          0010  0      .0000  .0000
    0000 03422          2.000          0010  0      .0000  .0000
    0000 03423          1.000          0010  0      .0000  .0000
    0000 03592          2.000          0010  0      .0000  .0000
    0000 03593          2.000          0010  0      .0000  .0000
    0000 99825-
RM                                1.000          0          .0000  .0000

                                TYPE =          KEY =
    
```

```

-----P/S OFFLINE STATISTICS-----
-----TRANSACTIONS-----
TYPE          ACCEPTED  NOT ACCEPTED  TOTAL
ADDS          174         0         174
CHANGES      0           0           0
DELETES       0           0           0
TOTAL TRANSACTIONS 174         0         174
PRODUCT STRUCTURE RUN ACTIVITY CONTROL NUMBER 115
    
```

Routing edit/load

The Routing Offline Maintenance Edit List (AMEB3) is printed when you choose edit or edit with load from the Master Menu. A transaction detail is printed above the statistics for any transaction that has been rejected. The Routing Offline Maintenance Audit List (AMEB4) is printed when you choose edit with load. These reports are printed when you make these selections.

The following numbers on reports AMEB3 and AMEB41 should match:

- Update number.
- The total transactions on the Routing Load list for the Routing file and the accepted add transactions on the Routing Transaction Edit list.
- The total transactions on the Routing Load report for the Routing Description file and the accepted add transactions on the Routing Transaction Edit list.
- The total milestone transactions on the Routing Load list for the Routing file and the accepted milestone transactions on the Routing Transaction Edit list.

NORTHCREEK INC.										ROUTING OFFLINE MAINTENANCE EDIT LIST			DATE 8/27/		
**	TIME	8.40.47	PAGE	1	AMEB3						UPDATE#	39			
TRANS	ITEM	NUMBER	OPER	DESCRIPTION	W/C	TBC	----	RUN	----	---	SETUP	---	MOVE	---	YIELD
OPER	TOOL	PROCESS	CODE	SEQ	NO.		MACH	LABOR	TIME	CREW	DAYS	STD	CURR	STA	
T	NO.	NO.													
EORT1000	99001		0030	PLATING AT VENDOR	VEN01	Q	.00	50.00	.00	0	5.00	.850	.900	10	
4632 TBC NOT 1,2,3,4,M,P,H,C, OR BLANK															

NORTHCREEK INC.										ROUTING OFFLINE MAINTENANCE EDIT LIST			DATE 8/27/		
**	TIME	8.40.47	PAGE	2	AMEB3						UPDATE#	39			
--ROUTING EDIT RUN STATISTICS--															
-----ADD TRANSACTIONS-----															
ACCEPTED	NOT	ACCEPTED	TOTAL												
3		1	4												
-----CHANGE TRANSACTIONS-----															
ACCEPTED	NOT	ACCEPTED	TOTAL												
0		0	0												
-----DELETE TRANSACTIONS-----															
ACCEPTED	NOT	ACCEPTED	TOTAL												
0		0	0												
---MILESTONE TRANSACTIONS---															
ACCEPTED	NOT	ACCEPTED	TOTAL												
0		0	0												
MILESTONE REMOVE TRANSACTIONS															
ACCEPTED	NOT	ACCEPTED	TOTAL												
0		0	0												
--INVALID TRANSACTION CODES--															
TOTAL															
0															

NORTHCREEK INC. ROUTING OFFLINE MAINTENANCE AUDIT LIST															DATE 8/27/		
** TIME 8.40.50 PAGE 1 AMEB41															UPDATE# 39		
*** TRANSACTIONS ***																	
ITEM NUMBER 99001 SPRAY UNIT																	
OPER M DESCRIPTION W/C TBC -----RUN----- ---SETUP---																	
MOVE TOOL OPER PROC STD CUR TRN SLT ACTION																	
															PRT		
SEQ NO	S																
0010		ASSEMBLE SHAFT	ASM10	1.00	.50	.50	1	.02	A11	10	PRO51	1.000	1.000				N
ADDED																	
0020		STAMP BRACKET ASM	STA10 1	1.00	.00	1.00	0	.50	STA-								
10 10	PROAA1	.950 .900	N	ADDED													
0040		FINAL INSPECTION	TEST 2	.00	5.00	.00	0	1.00		10		.750	.750				N
ADDED																	

NORTHCREEK INC. ROUTING OFFLINE MAINTENANCE AUDIT LIST															DATE 8/27/		
** TIME 8.40.50 PAGE 2 AMEB41															UPDATE# 39		
*** AFTER IMAGE ***																	
ITEM NUMBER 99001 SPRAY UNIT																	
OPER M DESCRIPTION W/C TBC -----RUN----- ---SETUP---																	
MOVE TOOL OPER PROC STD CUR TRN SLT PRT																	
SEQ NO	S																
0010		ASSEMBLE SHAFT	ASM10	1.00	.50	.50	1	.02	A11	10	PRO51	1.000	1.000				N
0020		STAMP BRACKET ASM	STA10 1	1.00	.00	1.00	0	.50	STA-10	10	PROAA1	.950	.900				N
0040		FINAL INSPECTION	TEST 2	.00	5.00	.00	0	1.00		10		.750	.750				N

NORTHCREEK INC. ROUTING OFFLINE MAINTENANCE AUDIT LIST															DATE 8/27/		
** TIME 8.40.50 PAGE 3 AMEB41															UPDATE# 39		
----- BATCH UPDATE STATISTICS -----																	
OFFLINE MAINTENANCE RECORDS																	
----- ROUTING FILE ACTION -----																	
DESCRIPTION	FILE	ACTION	----	READ	REJECTED	ACCEPTED		ADD	CHANGE	DELETE		ADD					
CHANGE	DELETE																
ROUTING TRANSACTIONS																	
ADDS				3	0	3		3									
CHANGES				0	0	0			0								
DELETES				0	0	0				0							
0																	
MILESTONE GROUP D/R																	
ROUTING DELETES				0	0	0					0						
0																	
DESCRIPTION TRANSACTIONS																	
ADDS				0	0	0											0
CHANGES				0	0	0											
0																	
DELETES				0	0	0											
0																	
MULTI-																	
DELETES				0	0	0											
0																	
TOTAL				3	0	3		3	0	0							0
0																	

Production Facility edit/load

The Production Facility Offline Maintenance Edit List (AMVTE) is printed when you choose edit or edit with load from the Master Menu. A transaction detail is printed above the transaction statistics for any transaction that has been rejected. The Production Facility Offline Maintenance Audit List (AMVTL) is printed when you choose edit with load. These reports are printed when you make these selections.

The following numbers on reports AMVTE and AMVTL should match: Accepted add transactions on the transaction edit list and the Total transactions on the load list.

```

NORTHCREEK IND.          PRODUCTION FACILITY OFFLINE MAINTENANCE EDIT LIST          DATE 8/21/
** TIME 16.35.27 PAGE    2 AMVTE

TRANSACTION CODE  FACILITY ID    AA001    FACILITY TYPE          1    PRODUCT LINE
                   DESCRIPTION    SAWS/SHEARING

      ADDED      DEPARTMENT    DP20    QUEUE TIME-DAYS      1.50    AVG QUEUE TIME      35.84
                FOREMAN        JLF     PRIME LOAD CODE      3       QUEUE MAD           .88
                LOCATION    B8E34   PN FAC ACTG CLS      AB1     TRACKING SIGNAL     1.60
                STD EFFICIENCY .88     AVG STD OUTPUT      94.52   MACH RESOURCE NO.
                AVG EFFICIENCY .85     AVG ACTL OUTPUT     111.20  LABOR RESOURCE NO.
                EXTRACT MACH BRKS          REPORTING METHOD      0       CLOCKING WINDOW     :00
                FACILITY STOCK LOCATION *****
                MACHINE          RUN LABOR          SETUP LABOR          OVERHEAD          OVERHEAD          PRODUCTION

BITMAP
PERCENT  CODE          CALENDAR  IDENTIFIER          RATE          RATE          RATE          RATE/
CURRENT  2.000          5.500          7.350          300.000          B          CALENDAR11  BI
G OL 'DEALLIE
STANDARD 2.000          5.200          7.035          300.000          B

          -----LENGTH-----          -----CAPACITY-----
          DESIRED  MAXIMUM          DESIRED  MAXIMUM
          SHIFT 1    7.5    9.0          3.0    4.0          POST TO OLDEST SCHED  ABC
          SHIFT 2     .0    .0          .0    .0          POST TO FUTURE SCHED  ABC
          SHIFT 3     .0    .0          .0    .0

-----PRODUCTION FACILITY TRANSACTIONS-----
-----ADD TRANSACTIONS-----
ACCEPTED  NOT ACCEPTED          TOTAL
   75          0          75

-----CHANGE TRANSACTIONS-----
ACCEPTED  NOT ACCEPTED          TOTAL
   0          0          0

-----DELETE TRANSACTIONS-----
ACCEPTED  NOT ACCEPTED          TOTAL
   0          0          0

-----INVALID RECORD CODE TRANSACTIONS-----
TOTAL
   0
    
```

NORTHCREEK IND. PRODUCTION FACILITY OFFLINE MAINTENANCE AUDIT LIST DATE 8/21/
 ** TIME 16.35.27 PAGE 2 AMVTL

TRANSACTION CODE	FACILITY ID	AA001	FACILITY TYPE	1	PRODUCT LINE	
ADDED	DESCRIPTION	SAWS/SHEARING				
	DEPARTMENT	DP20	QUEUE TIME-DAYS	1.50	AVG QUEUE TIME	35.84
	FOREMAN	JLF	PRIME LOAD CODE	3	QUEUE MAD	.88
	LOCATION	B8E34	PN FAC ACTG CLS	AB1	TRACKING SIGNAL	1.60
	STD EFFICIENCY	.88	AVG STD OUTPUT	94.52	MACH RESOURCE NO.	
	AVG EFFICIENCY	.85	AVG ACTL OUTPUT	111.20	LABOR RESOURCE NO.	
	EXTRACT MACH BRKS		REPORTING METHOD	0	CLOCKING WINDOW	:00
	FACILITY STOCK LOCATION	*****				

MAP	MACHINE	RUN LABOR	SETUP LABOR	OVERHEAD	OVERHEAD	PRODUCTION	BIT
-----	---------	-----------	-------------	----------	----------	------------	-----

PERCENT CODE	RATE	RATE	RATE	RATE/		
	CALENDAR	IDENTIFIER				
' DEALLIE	CURRENT	2.000	5.500	7.350	300.000	B CALENDAR11 BIG OL
	STANDARD	2.000	5.200	7.035	300.000	B

	-----LENGTH-----	-----CAPACITY-----
	DESIRED MAXIMUM	DESIRED MAXIMUM
SHIFT 1	7.5 9.0	3.0 4.0
SHIFT 2	.0 .0	.0 .0
SHIFT 3	.0 .0	.0 .0

-----PRODUCTION FACILITY TRANSACTIONS-----

ACCEPTED	NOT ACCEPTED	TOTAL
75	0	75

-----CHANGE TRANSACTIONS-----

ACCEPTED	NOT ACCEPTED	TOTAL
0	0	0

-----DELETE TRANSACTIONS-----

ACCEPTED	NOT ACCEPTED	TOTAL
0	0	0

-----INVALID RECORD CODE TRANSACTIONS-----

TOTAL
0

Item Master file maintenance

Display AMVT06 appears when you use the Item Master file maintenance. The Item Master File Maintenance Control Sheet prints after you update the Item Master file using file maintenance.

The following numbers on display AMVT06 and report AMVT0 should match:

- Adds entered and items added
- Changes entered and items changed
- Deletes entered and items deleted.

```

DATE **/**/**      ITEM MASTER FILE MAINTENANCE      STATUS      AMVT06  **
                                SESSION STATISTICS
                                ADDS ENTERED                0
                                CHANGES ENTERED               1
                                DELETES ENTERED                6
                                TOTAL TRANSACTIONS              1
                                MAINTENANCE NUMBER              9

                                F24 END OF JOB
    
```

NORTHCREEK IND. ITEM MASTER FILE MAINTENANCE CONTROL SHEET

DATE 6/01/

** TIME 16.22.25 PAGE 3 AMVT0

UPDATE# 26

```

----- TRANSACTION UPDATE STATISTICS -----
      ITEMS      ITEMS      ITEMS
      ADDED      CHANGED    DELETED
        0           1           6
    
```

Product structure file maintenance

Display AMEU18 appears when you use Product Structure file maintenance. The Product Structure Transaction List and the Product Structure Update Audit List are printed after you have released that batch of transactions for batch update.

The following numbers on display AMEU18 and reports AMEU5 and AMEB12 should match if there are no errors detected during update:

- Batch statistics on the display and entered transaction statistics on the transaction list
- Transaction statistics on the transaction list and update statistics on the update audit list.

```

DATE **/**/**      PRODUCT STRUCTURE FILE MAINTENANCE      BATCH STATUS AMEU18  **
                                BATCH STATISTICS                                BATCH ***
                                ADDS ENTERED                                1
                                CHANGES ENTERED                             1
                                DELETES ENTERED                             1
                                SAME-AS-EXCEPTS                           7
                                MASS REPLACES                               3
                                MASS DELETES                                5
                                STRUCTURE DELETES                           5
                                ADDS GENERATED                              0
                                CHANGES GENERATED                           0
                                DELETES GENERATED                           0
                                TOTAL TRANSACTIONS                           23
                                QUANTITY TOTAL                               6,341
                                F04 UPDATE NOW
                                F20 DELETE BATCH
                                F23 SUSPEND BATCH
                                F24 CLOSE BATCH
    
```

```

NORTHCREEK IND.          PRODUCT STRUCTURE TRANSACTION LIST          DATE **/**/
** TIME 11.17.26 PAGE   2  AMEU5                                     OPER DAW          UPDATE#   6
-----BATCH 2 ENTERED TRANSACTION STATISTICS-----
TYPE          ENTERED      ADDS      CHANGES      DELETES      TOTAL
SAME-AS-EXCEPTS      4          7
MASS DELETES           1
MASS REPLACES          1          2          0          3
ADDS                   1
CHANGES               1
DELETES                1
STRUCTURE DELETES      1          5          5
TOTAL TRANSACTIONS     10          8          2          10      23
BATCH 2 RESULTING TRANSACTION STATISTICS
-----TRANSACTIONS-----
TYPE          TOTAL
ADDS          9
CHANGES      3
DELETES      11
TOTAL TRANSACTIONS 23
    
```

NORTHCREEK IND. PRODUCT STRUCTURE TRANSACTION LIST DATE **/**/
** TIME 11.17.26 PAGE 3 AMEU5 OPER DAW UPDATE# 6

-P/S TRANSACTION LIST STATISTICS-

-----TRANSACTIONS-----
TYPE TOTAL
ADDS 9
CHANGES 3
DELETES 11
TOTAL TRANSACTIONS 23

PRODUCT STRUCTURE RUN ACTIVITY CONTROL NUMBER 9

NORTHCREEK IND. PRODUCT STRUCTURE UPDATE AUDIT LIST DATE **/**/
** TIME 11.17.54 PAGE 13 AMEB12 OPER DAW UPDATE# 6

-----P/S UPDATE STATISTICS-----

-----TRANSACTIONS-----
TYPE ACCEPTED NOT ACCEPTED TOTAL
ADDS 9 0 9
CHANGES 3 0 3
DELETES 11 0 11
TOTAL TRANSACTIONS 23 0 23

PRODUCT STRUCTURE RUN ACTIVITY CONTROL NUMBER 9

Production facility file maintenance

Display AMVT75 appears when you use the Production Facility file maintenance. The Production Facility Control Sheet prints after you update the Production Facility file using file maintenance.

The following numbers on display AMVT75 and report AMVT7 should match:

- Adds entered and facilities added
- Changes entered and facilities changed
- Deletes entered and facilities deleted.

```

DATE **/**/**      PRODUCTION FACILITY MAINTENANCE      STATUS      AMVT75  **
                                SESSION STATISTICS
                                MAINTENANCE NUMBER      10
                                ADDS ENTERED                1
                                CHANGES ENTERED            1
                                DELETES ENTERED             1
                                TOTAL TRANSACTIONS           3

                                F24 END OF JOB
    
```

```

NORTHCREEK IND.      PRODUCTION FACILITY MAINTENANCE CONTROL SHEET      DATE 8/31/
** TIME 9.15.15 PAGE 2 AMVT7
                                UPDATE# 137
----- TRANSACTION UPDATE STATISTICS -----
FACILITIES      FACILITIES      FACILITIES
ADDED           CHANGED           DELETED
1               1                 1
    
```

Variable capacity file maintenance

Display AMVTC6 appears when you use the Variable Capacity option of Production Facility Maintenance. The Variable Capacity Master File Maintenance Control Sheet prints after you update the Variable Capacity file using file maintenance.

The following numbers on display AMVT6 and report AMVTC should match:

- Adds entered and variable capacity records added
- Changes entered and variable capacity records changed
- Deletes entered and variable capacity records deleted
- Delete All entered and number of facilities for which all variable capacity records were deleted
- The total number of transactions processed.

```

DATE **/**/** A2      VARIABLE CAPACITY MAINTENANCE      STATUS      AMVTC6  **

      MAINTENANCE NUMBER          ***

      -----SESSION STATISTICS-----
      ADDS ENTERED                *****
      CHANGES ENTERED           *****
      DELETES ENTERED            *****
      DELETE ALL ENTERED         *****

      TOTAL TRANSACTIONS          *****

                                     F24 END OF JOB
    
```

```

NORTHCREEK IND.      VARIABLE CAPACITY MASTER FILE MAINTENANCE      DATE 10/24/
** TIME 10.37.37 PAGE 2 AMVTC      CONTROL SHEET      OPER JAG      UPDATE# 5
    
```

```

-----TRANSACTIONS-----
TYPE          TOTAL
1 - ADDS ENTERED      1
2 - CHANGES ENTERED  1
3 - DELETES ENTERED   1
9 - DELETE ALL ENTERED 1
TOTAL TRANSACTIONS    4
    
```

NORTHCREEK IND.		ROUTING TRANSACTION LIST				DATE 9/06/				
**	TIME 9.35.44	PAGE 2	AMEU9					UPDATE#	62	
		-BATCH 3 ENTERED TRANSACTION STATISTICS-								
RECORDS		----- TRANSACTION RECORDS WRITTEN -----								
-----	TYPE	READ	FOR ROUTING FILE				FOR DESCRIPTION FILE			
-----	TOTAL		ADD	CHANGE	DELETE	RTG DEL	ADD	CHANGE	DELETE	MU
ROUTING TRANSACTIONS										
LTI DEL										
ADDS	0	0	0							
CHANGES	1	1		1						
DELETES	0	0			0					
SAE HEADER	0	0	0				0			
ROUTING DELETES	0	0				0				
DESCRIPTION TRANSACTIONS										
ADDS	0	6					6			
CHANGES	0	0						0		
DELETES	0	0							0	
MULTI DELETES	0	0								
MILESTONE TRANSACTIONS										
TOTAL	0	7	0	1	0	0	6	0	0	

NORETHCREEK IND.		ROUTING TRANSACTION LIST				DATE 9/06/				
**	TIME 9.35.44	PAGE 3	AMEU9					UPDATE#	62	
		-----TRANSACTION LIST STATISTICS-----								
-----	ROUTING TRANSACTIONS									
	ADDS	0								
	CHANGES	1								
	DELETES	0								
	ROUTING DELETES	0								
	MILESTONE TRANSACTIONS	0								
-----	DESCRIPTION TRANSACTIONS									
	ADDS	6								
	CHANGES	0								
	DELETES	0								
	MULTI DELETES	0								
	TOTAL TRANSACTIONS	7								

NORTHCREEK IND. ROUTING UPDATE AUDIT LIST													DATE 10/02/		
** TIME 14.31.42 PAGE 1 AMEB42													UPDATE# 1		
*** BEFORE IMAGE ***															
ITEM NUMBER 99005 COMPRESSOR															
OPER M	DESCRIPTION	W/C TBC	-----RUN-----	---SETUP---	MOVE	TOOL OPER	PROC	STD	CUR	TRN	SLT	PRT			
SEQ NO S			MACH	LABOR	TIME	CREW	DAYS	NO. STAT	NO.	YIELD	YIELD	CDE NO.	FLG		
0010		ASM10	.01	.01	.00	0	.00	10		1.000	1.000		Y		
0020		ASM10	.33	.99	.88	2	.00	10		.000	1.000		Y		
0030	Op 30 Test Zero-out	TEST	345.67	345.67	345.67	2	4.44	10		1.000	1.000		Y		
0050	Op 50 -9999 runmc	STA10	99.99	.00	.00	0	.00	10		1.000	1.000		Y		
NORTHCREK IND. ROUTING UPDATE AUDIT LIST													DATE 10/02/		
91 TIME 14.31.42 PAGE 2 AMEB42													UPDATE# 1		
*** TRANSACTIONS ***															
ITEM NUMBER 99005 COMPRESSOR															
OPER M	DESCRIPTION	W/C TBC	-----RUN-----	---SETUP---	MOVE	TOOL OPER	PROC	STD	CUR	TRN	SLT	PRT			
MOVE				ACTION											
BATCH															
SEQ NO S			MACH	LABOR	TIME	CREW	DAYS	NO. STAT	NO.	YIELD	YIELD	CDE NO.	FLG		
0060	OPERATION 60	ASM20	.00	.00	.00	1	.00	10		1.000	1.000		N		
1 ADDED															
NORTHCREEK IND. ROUTING UPDATE AUDIT LIST													DATE 10/02/		
** TIME 14.31.42 PAGE 3 AMEB42													UPDATE# 1		
*** AFTER IMAGE ***															
ITEM NUMBER 99005 COMPRESSOR															
OPER M	DESCRIPTION	W/C TBC	-----RUN-----	---SETUP---	MOVE	TOOL OPER	PROC	STD	CUR	TRN	SLT	PRT			
SEQ NO S			MACH	LABOR	TIME	CREW	DAYS	NO. STAT	NO.	YIELD	YIELD	CDE NO.	FLG		
0010		ASM10	.01	.01	.00	0	.00	10		1.000	1.000		Y		
0020		ASM10	.33	.99	.88	2	.00	10		.000	1.000		Y		
0030	Op 30 Test Zero-out	TEST	345.67	345.67	345.67	2	4.44	10		1.000	1.000		Y		
0050	Op 50 -9999 runmc	STA10	99.99	.00	.00	0	.00	10		1.000	1.000		Y		
0060	OPERATION 60	ASM20	.00	.00	.00	1	.00	10		1.000	1.000		N		
NORTHCREEK IND. ROUTING UPDATE AUDIT LIST													DATE 10/02/		
** TIME 14.31.42 PAGE 4 AMEB42													UPDATE# 1		
----- BATCH UPDATE STATISTICS -----															
RECORDS															
----- ROUTING FILE ACTION -----															
DESCRIPTION	FILE ACTION	----	READ	REJECTED	ACCEPTED	ADD	CHANGE	DELETE	ADD	CH					
ANGE	DELETE														
ROUTING TRANSACTIONS															
ADDS			1	0	1	1									
CHANGES			0	0	0		0								
DELETES			0	0	0			0							
0															
MILESTONE GROUP D/R															
ROUTING DELETES			0	0	0			0							
0															
DESCRIPTION TRANSACTIONS															
ADDS			0	0	0					0					
CHANGES			0	0	0										
0															
DELETES			0	0	0										
0															
MULTI-															
DELETES		0	0	0											
0															
TOTAL			1	0	1	1	0	0		0					
0															

Product structure file reorganization

When the Product Structure file is reorganized, the Item Master counts (low level code, number of single-level components, and direct usages) are recalculated. If you have run the application tailoring questionnaire to change the user sequence options, the user sequence fields are modified to reflect the changes you made.

Removing a user sequence field can result in duplicate parent/component records. If duplicate records exist, the Product Structure Reorganization report prints listing the exceptions.

All product structure batches in an update status are suspended so that they can be closed again and reprocessed.

```

NORTHCREEK IND.                PRODUCT STRUCTURE REORGANIZATION                DATE **/**/
** TIME 14.15.47  PAGE 1  AMEW1
PARENT 99001      SPRAY UNIT                LLC 00      STANDARD BATCH QUANTITY      1.000
LL SEQ COMPONENT  DESCRIPTION-TRUNCATED      QUANTITY   EFFECTIVE DATES FIRST  LT F/O PLANNING COST ROLL
CD NO                PER          FROM          TO OPER ADJ      FACTOR  FACTOR
01 0010 03590-F3    SWITCH FEATURE                1.000
04 .0000 .0000    DUPLICATE-DELETED
01 0010 27006-F2    TANK SIZE FEATURE            1.000
05 .0000 .0000    DUPLICATE-DELETED
    
```

Routing file reorganization

When the Routing file is reorganized, the Item Master routing counts are recalculated and the Routing Audit report (AMEX1) is printed.

All routing batches in update status are suspended so that they can be closed again and reprocessed.

```
NORTHCREEK IND.                                ROUTING AUDIT                                DATE **/**/
** TIME 11.06.26 PAGE 1  AMEX1                                                         UPDATE#    10

-----ROUTING AUDIT STATISTICS-----
NO. OF ITEMS WITH ROUTINGS                      47
NO. OF ROUTING OPERATIONS                       216
MAXIMUM NO. OF OPERATIONS PER ROUTING           10
MINIMUM NO. OF OPERATIONS PER ROUTING           1
AVERAGE NO. OF OPERATIONS PER ROUTING           4.6
NO. OF FACILITIES USED                           17
MAXIMUM USAGES OF A FACILITY                     39
MINIMUM USAGES OF A FACILITY                     2
AVERAGE USAGES OF A FACILITY                    12.8
```

Percent changes

When you make a percent change to an item class from the Costing menu, the Item Cost Percent Change Audit report is printed.

```

NORTHCREEK IND.                ITEM COST PERCENT CHANGE AUDIT      OPER      DATE 11/28/**  TIME 10.08.11
PAGE      1      AMET5
-----T O T A L S-----
PERCENT CHANGE APPLIED TO      CURRENT AND PURCHASE THIS LEVEL
                                STANDARD
AMOUNT OF PERCENT CHANGE                .01 PERCENT
UPDATED ITEM CLASS                    01
NO. OF ITEMS IN THIS ITEM CLASS        9
NO. OF ITEMS UPDATED                   0
    
```

When you complete file maintenance, the Facility Percent Change Audit Report is printed.

```

NORTHCREEK IND.                FACILITY PERCENT CHANGE AUDIT REPORT      OPER DAW      DATE **/**/
** TIME 13.49.47  PAGE 1      AMET8
NO. OF FACILITIES PROCESSED, PERCENT CHANGE---00013
    PERCENT CHANGE WAS-----CURRENT AND STANDARD
    PERCENT CHANGE WAS FOR---SETUP LABOR RATE
    PERCENT CHANGE WAS FOR--- 50.00 PERCENT
NO. OF FACILITIES PROCESSED, WCFLG ON-----00000
    NO. OF WCFLG'S WHICH WERE 'C'---00000
    NO. OF WCFLG'S WHICH WERE 'S'---00000
    NO. OF WCFLG'S WHICH WERE 'B'---00000
NO. OF ITEM MASTERS PROCESSED, PERCENT CHANGE-----00034
    
```

Appendix A. Offline file load and data entry

As an alternative to entering master file or transaction data interactively using XA, you can prepare the information offline in files on a separate system. The files that you create or update offline can then be loaded into the XA system and processed by XA. Offline files can be created on a diskette or written to a disk file. The same format requirements apply to both.

To use data from offline files in XA, you must:

- Gather the information to be entered.
- Create a file with the information on diskette or disk. The file must follow the corresponding file layout. See “Viewing and printing file record layouts” for instructions on obtaining the file layout.
- Load the offline files by selecting a XA menu option.

This appendix describes these activities.

Gathering the information

See the data entry forms for offline entry in Chapter 9, “Forms”. They explain exactly what information you need, and show you the format and field length.

Fill out the input forms as though you were going to use them to enter the data directly into the system.

Creating an offline file

You can create offline files on diskette or disk. You can create the files in several ways. For example:

- You can create the records with a user-written program on an offline data entry device, and write them to a disk or diskette file.
- You can have another system create the records on tape using the required file layout. You copy the tape file to disk or diskette.
- You can have a remote location send the records via telecommunications. You can write them to a disk or diskette file.

It does not matter how or where the records originate. As long as they reside in a disk or diskette file that has the defined file layout, they can be processed by XA.

File format

You can print a copy of the file record layout. The layout gives you the following information for each enterable field:

- A brief description of the field
- Whether the field is alphabetic or numeric (signed or packed) (A/S/P)
- The starting position of the field in the record (Start)
- The length of the field
- For numeric fields, the number of decimal positions in the field (Dec).

- The short field name (6 characters).

File name

Assign a special name to each file, or use the default name listed here. You must enter the name when you load the file.

Table 10-1. Required file names

Master file to be loaded or updated	Offline file name (default)	Externally described file name
Item Master file - A record	IMDSKTA	TMP107
Item Master file - B record	IMDSKTB	TMP108
Item Master file - C record	IMDSKTC	TMP109
Routing file	RTGDKT	RTGDKT
Product Structure file	PSDSKT	PSDSKT
Production Facility file	PFDSKT	PFDSKT

Viewing and printing file record layouts

Use Cross Application Support to obtain a spool file of the file record layout of the file you will be working with. The following is a short version of the steps to follow. See the *CAS User's Guide* for more detailed information.

1. On the CAS main menu, select option 2 (Reports).
2. On the Reports, select option 5 (File Record Layout).
3. The Select Application panel (AMZ12) appears.
 - If you want to print layouts of all the files PDM uses, select Product Data Management. The file record layouts are spooled to your spool file.
 - If you want to print only specific files, use **F22**. The Specify files panel (AMZ122) appears. Accept the default of N in the Print characteristics field to see a brief report. Type Y if you want to see a narrative about characteristics about each field in the file. (Depending on the number of fields, this can be a lengthy report.)
4. When the reports are spooled to you, you can view or print the file layouts.

You must use the name shown in the Externally Described file name column of Table 10-1, "Required file names" to obtain the file record layout.

Entering data into offline files

Regardless of what offline method you use for entering master file data, the data in the files must be organized in the layout shown in the file record layout.

The alphabetic/numeric column (A/S/P) in the layouts contains important information for setting up the offline files. The letter A indicates alphabetic fields. Numeric fields are shown by the letter S or P, which indicates either a signed (+/-) or a packed numeric field. You enter data into both types of fields using the same field lengths available in online entry.

For each of the offline files some fields are required (that is, you must enter valid data for them) and the rest of the fields are optional. Not entering data in the required fields causes errors.

Special data requirements

When you enter the information for an offline record, type in the transaction code shown on the input form as the first eight characters of the record.

If you enter dates, type them in using the same date format you use for the System i and for all XA applications.

Type the information carefully. The system will check for errors when you process the files. If it finds errors, you must correct the records with errors before you can finish processing them.

Loading offline files into PDM

Once you have entered the master file data into your offline files, select the File Maintenance option on the Main Menu (AMEM00), select the Offline File Maintenance option on the File Maintenance menu (AMEM50), and then select the appropriate option for the file you are loading on the Offline File Maintenance menu (AMEM55). The Offline Maintenance Options (AMVPOF) display appears. The fields on this display are required.

You can also use options on the Cross Application Support (CAS) Load Data From Offline Files menu (AMZM81). The CAS method takes you to the Copy Offline Files display (AXVOL1). The fields on this display are required. See the *CAS User's Guide* for general instructions for using this display.

Note: It is recommended that you choose the **Edit Only** option first when you are doing an initial file load. This provides a listing of records that have errors. One of the following reports is printed, depending on which file you are editing:

- Item Master Offline Maintenance Edit List (AMKE1)
- Routing Offline Maintenance Edit List (AMEB3)
- Product Structure Offline Maintenance Edit List (AMEB0)
- Production Facility Offline Maintenance Edit List (AMVTE) (This report is printed through PDM only.)

Correcting the errors before you do the initial file load makes the process much simpler. When the transaction edit report shows no errors, select the **Edit and Update** option.

Processing offline files

After you enter all the requested information on display AXVOL1 or AMVPOF, the system begins checking the validity of the data in the offline files. The results of these checks appear in one of the following reports, depending on which file you are loading:

- Item Master Offline Maintenance Audit List (AMKE3)
- Routing Offline Maintenance Audit List (AMEB41)
- Product Structure Offline Maintenance Audit List (AMEB11)
- Production Facility Offline Maintenance Audit List (AMVTL) (This report is printed through PDM only.)

To continue processing the rejected records, return to the offline data entry utility you used to create the offline records and correct the errors identified in the load report. Remember, if you selected N (No) for the delete offline files question earlier on display AXVOL1 or AMVPOF, you need to delete the offline file and restore the corrected version.

When the rejected records have been corrected and the edit report shows no errors, select the **Edit and Update** option on one of the PDM Offline Maintenance Options displays or the **Edit Load** option on Load Data From Offline Files menu (AMZM81). The records accepted at this time are entered directly into PDM.

Entering changes and deletions

Required fields for changes and deletions are sometimes different from the fields required for additions.

Use the following guidelines to make changes and deletions:

- To change a record, type in valid data for the required fields and any optional fields you want to change. Only fields containing valid data are edited and updated to the master file. Optional fields for which you do not want to make changes should be entered as either all blanks (alphanumeric fields) or all zeros (numeric fields).
- To change an alphanumeric field to all blanks, type in all asterisks (*) for that field.
- To change a numeric field to zero, type in all nines negative (999999-).
- To delete a record, type in valid data for the required fields only.

Note: To delete an item from the Item Master file, use the delete transaction code for the A record (E0IA0301) and the item number. This deletes the A, B, and C records for the item.

Changing the **Item type**, **Item Class**, **Inventory Flag**, and **Standard Batch Quantity** fields in the Item Master A record would look like this:

Field Entered	Field Name	Value Entered	Action/Reason
Change Transaction Code	TRID	E0IA0201	A required field
DAE generated sequence number	DAESQ	000000000	A numeric field with no change
MPOI generated sequence number	MPOSQ	000000000	A numeric field with no change
Level of response flag	RSPFL		An alphanumeric field with no change
Item number	ITNBR	123456789	A required field
Item description	ITDSC		An alphanumeric field with no change
Item type code	ITTYP	F	An alphanumeric field being changed
Item class	ITCLS	****	An alphanumeric field being changed to all blanks
Inventory flag	INVFG	02	A numeric field being changed
Standard batch quantity	SBQTY	9999999999-	A numeric field being changed to zero

Item Master (ITMDKT) file

The ITMDKT file is a logical file across multiple physical files (IMDSKTA, IMDSKTB, and IMDSKTC). The A record is always required. The B record is required if product costing was selected during application tailoring, if MRP is installed and interfacing, or if MPSP is installed and interfacing. If you do not specify a B record, it is created automatically. For item type 3 and 4, the C record is created automatically unless it is entered during initial offline file load.

Note: If EPDM is activated, file maintenance to this file is handled through the EPDM application.

As a convenience, the three offline load physical files, IMDSKTA, IMDSKTB, and IMDSKTC, and one logical file, ITMDKT, are provided in a save file called SFITMDKT in the AMXLIBx library. If you plan to use these files to load your offline data, you can follow these steps:

1. Restore IMDSKTA, IMDSKTB, IMDSKTC, and ITMDKT to your user library, using the following command:

```
RSTOBJ OBJ(IMDSKTA IMDSKTB IMDSKTC ITMDKT)
SAVLIB(ITMDKT) DEV(*SAVF)
SAVF(AMXLIBx/SFITMDKT)
RSTLIB(your library name)
```

where x is the first character of your XA environment “xy”.

2. if you are entering the data on the System i, use Data File Utility (DFU) to establish a data entry session for each of the Item Master formats (A, B, C). Enter all data for each format (A, B, C).

If you are entering data from some other source, make sure that each position of the record has valid data according to the offline file layouts (for example, numeric fields have numeric data). If you have transferred the data to the eSeries by way of a record-length (flat) file, you can use the copy file function (CPYF) to copy the data from the record-length file to the appropriate physical file (IMDSKTA, IMDSKTB, or IMDSKTC). Specify the “no check” option for the **Record Format Field Mapping** option (FMTOPT=*NOCHK).

3. Once you have put the data into the offline physical files (IMDSKTA, IMDSKTB, IMDSKTC), select Item Master offline file maintenance and select the default file (ITMDKT) in your user library as the file to load. Before you run the offline load, be sure to add a logical file member to ITMDKT, which is built over the three physical files IMDSKTA, IMDSKTB, and IMDSKTC. The offline load process copies the data from the offline physical files and properly sequences the records by transaction ID and item number.
4. Once the copy file has been completed, select Item Master offline file maintenance and specify the record-length file as the file to load.

The following table gives you an overview of the Item Master records and the sequence in which they should be entered.

Sequence	Record	Description
1	A	General item information
2	B	Costing information
3	C	Purchasing information

Record type A: Item information (IMDSKTA)

The following fields are required to process an item master record.

Required field	Field name	Value required	Required for
Transaction Code	TRID	Must be E0IA0101 (Add), E0IA0201 (Change), or E0IA0301 (Delete)	All records
Item Number	ITNBR	Valid item number	All transaction codes
Item Description	ITDSC	Description of the item	E0IA0101 only
Item Type Code	ITTYP	Must be 0, 1, 2, 3, 4, 9, F, or K	E0IA0101 only
Unit of Measure	UNMSR	Valid unit of measure	E0IA0101 only

Record type B: Costing information (IMDSKTB)

The following fields are required for costing information. The item number must match the item number you enter for the A record.

Required field	Field name	Value required	Required for
Transaction Code	TRID	Must be E0IB0100 (Add), E0IB0200 (Change), or E0IB0300 (Delete)	All records
Item Number	ITNBR	Valid item number	All transaction codes

Record type C: Purchasing information (IMDSKTC)

The following fields are required for purchasing information. The item number must match the item number you enter for the A record.

Required field	Field name	Value required	Required for
Transaction Code	TRID	Must be E0IC0100 (Add), E0IC0200 (Change), or E0IC0300 (Delete)	All records
Item Number	ITNBR	Valid item number	All transaction codes

Routing file (RTGDKT)

The RTGDKT file is a physical file with multiple record types. The Item Master and Production Facility files must be installed before you can process offline routing operation records. An Item Master A-record and A-record extension must exist for every item in a routing and a Production Facility record must exist for every facility ID used.

As a convenience, the offline load physical file, RTGDKT is provided in the AMXLIBx library. If you plan to use this file to load your offline data, it is suggested that you follow these steps:

1. Restore RTGDKT file in your user library, using the following command:

```
RSTOBJ OBJ(RTGDKT)
SAVLIB(ROUTNG01) DEV(*SAVF)
SAVF(AMXLIBx/SFROUTNG01)
RSTLIB(your library name)
```

where x is the first character of your XA environment “xy”.

2. Using Data File Utility (DFU), establish a data entry session for the offline file and enter all of the offline transactions for the file.
3. When you have completed the DFU session, select Routing Offline Maintenance and specify the offline file in your user library as the file to load.

Note: Offline routing operation records are added to the routing master file according to the transaction code. If you use the add code (E0RT1000), only routing operation information is added. Information in the additional description fields and milestone fields is ignored. If you use the add additional description code (E0RT2000), only the additional description fields are used to update the master file record. In addition, if you attempt to add a routing operation in the same file as an additional description operation, the additional description will show an error on the edit report because the routing is not yet in the master file.

Resource constraint 1 (**FCP1**) and Resource constraint 2 (**FCP2**) are fields in RTEDIT and the database. These fields are used in the FCPS application to define additional resource constraints when FCPS does the finite capacity generation run.

Scheduling specific work centers

The following discussion applies only if PDM*Plus* and FCPS are installed and interfacing.

Your routing data (MOROUT or ROUTNG) specifies a work center (WC) for each operation. FCPS uses operation and WC definitions to generate finite capacity schedules for the work center. In most cases, the WC definition in PDM enables FCPS to generate realistic production schedules. However, there are times when the general definition for a particular work center is not adequate. Sometimes, a WC definition (in WRKCTR) and the corresponding resource group definitions (in FCPS) do not properly represent certain realities on the shop floor. The three common cases of this are:

- An item prefers the WC machines in a different order than is represented by the general WC definition.
- An item is limited to using only a subset of the machines in a work center.
- There is a combination of the first two cases.

The first part to solving this problem involves *PDMPlus*. Here, you can specify a replacement work center in the **FCP1** field. The standard work center will still be used in ROUTNG (and MOROUT), thus avoiding creating "extra capacity" and adversely affecting CRP. Using *PDMPlus*, you would enter *MS21 (for example) in the **FCP1** field, as a replacement for the general WC ID MS020 that is in ROUTNG.WKCTR. The asterisk tells the Update Orders program in FCPS that this work center replaces the one specified in ROUTNG. If an asterisk is not entered, the entry in the **FCP1** field is the standard additional resource required on the job step.

In the second part to solving this problem you would use the Resource Group editor in FCPS to define the replacement WC MS21. When defining the Resource Group, you would specify the WC machines in the order preferred by this item and/or specify only the machines that are valid for this item. This enables FCPS to use the MS21 definition for this item when it generates production schedules.

Several items can share the same Resource Group definition.

The following fields are required to create and update a routing record.

Required Field	Field Name	Value Required	When Required
Transaction Code	TRID	Must be E0RT0500, E0RT0800, E0RT0900, E0RT1000, E0RT1100, E0RT1800, E0RT1900, E0RT2000, E0RT2100, or E0RT3000	For all records
Item Number	ITNBR	Must be the parent item number	For all transaction codes
Operation Sequence Number	OPSEQ	A valid sequence number	For E0RT0900, E0RT1000, E0RT1100, E0RT1800, E0RT1900, E0RT2000, and E0RT2100 only
Production Facility ID	WKCTR	A valid ID	For E0RT0900, E0RT1000, and E0RT1100 only
Operation Description Sequence Number	DSQNO	A valid description sequence number	For E0RT1900, E0RT2000, and E0RT2100 only
Beginning Operation	BEGOP	A valid operation sequence number	For E0RT0500 and E0RT3000 only
Ending Operation	ENDOP	A valid operation sequence number	For E0RT3000 only
Milestone Type	MTYPE	Must be J or F	For E0RT3000 only
E0RT0500	Milestone delete		
E0RT0800	Total routing delete		
E0RT0900	Delete record		
E0RT1000	Add record		
E0RT1100	Change record		
E0RT1800	Additional description multiple delete		

E0RT1900	Additional description delete
E0RT2000	Additional description add
E0RT2100	Additional description change
E0RT3000	Milestone define

Product Structure file (PSDSKT)

The PSDSKT file is a physical file containing product structure information. An Item Master A-record and A-record extension must exist for each item in a product structure.

As a convenience, the offline load physical file, PSDSKT is provided in the AMXLIBx library. If you plan to use this file to load your offline data, it is suggested that you follow these steps:

1. Restore PSDSKT file to your user library, using the following command:.

```
RSTOBJ OBJ(PSDSKT)
SAVLIB(PSTRUCS0) DEV(*SAVF)
SAVF(AMXLIBx/SFPSTRUCS0)
RSTLIB(your library name)
```

where x is the first character of your XA environment "xy".

2. Using Data File Utility (DFU), establish a data entry session for the offline file and enter all of the offline transactions for the file.
3. When you have completed the DFU session, select Product Structure Offline Maintenance and specify the offline file in your user library as the file to load.

Required Field	Field Name	Value Required	When Required
Transaction Code	TRID	Must be E0PS0400, E0PS0500, E0PS0600, or E0PS0700	For all records
Parent Item Number	PINBR	Must be a parent item number	For all transaction codes
Component Item Number	CINBR	Must be a component item number	For E0PS0500, E0PS0600, and E0PS0700 only
Quantity Per Unit	QTYPR		For E0PS0500, E0PS0600, and E0PS0700 only
User Sequence	USRSQ	Usrsq/cinbr combination must already exist in PSTRUC	For E0PS0500 and E0PS0700 only

Note: USRSQ is a required field in change or delete mode only if E05 = yes and the user sequence number already exists in the PSTRUC file.

E0PS0400 Total structure delete
E0PS0500 Delete record
E0PS0600 Add record
E0PS0700 Change record

Production Facility file (PFDSKT)

The PFDSKT file is a physical file containing production facility information.

As a convenience, the offline load physical file, PFDSKT is provided in the AMXLIBx library of XA. If you plan to use this file to load your offline data, it is suggested that you follow these steps:

1. Restore PFDSKT file to your user library, using the following command:

```
RSTOBJ OBJ(PFDSKT)
SAVLIB(WRKCTRL0) DEV(*SAVF)
SAVF(AMXLIBx/SFWRKCTRL0)
RSTLIB(your library name)
```

where x is the first character of your XA environment "xy".

2. Using Data File Utility (DFU), establish a data entry session for the offline file and enter all of the offline transactions for the file.
3. When you have completed the DFU session, select Production Facility Offline Maintenance and specify the offline file in your user library as the file to load.

Required Field	Field Name	Value Required	When Required
Transaction Code	TRID	Must be E0PF0100 (Add), E0PF0200 (Change), or E0PF0300 (Delete)	For all records
Production Facility ID	WKCTR	A valid ID	For all transaction codes
Production Facility Description	WCDSC	A description of the production facility	For E0PF0100 only
Extract Machine Break	BRKXT	Must be 0 or 1	For E0PF0100 only

Appendix B. Security areas

The options on the CAS Security Maintenance menu (AMZM38) allow you to protect application tasks from unauthorized users. You can define security areas and then define specific tasks associated with each area.

Security areas protect access to a group of menu options. The following table shows the application security areas and their associated menu options and task IDs. To print a report of all application areas, see the description of the Generate reports option in the Security Maintenance chapter of the *CAS User's Guide*.

Security area	Menu/option	Description	Task ID
PDM Shared Application Security Clearances	AMEM03/1	Item Master Selections	AMVE1
	AMEM03/8	Item Foreign Language Descriptions	AMVCOPVR
	AMEM05/1	Item Master	AMVP5A
	AMEM05/5	Item Base Price	AMEP59
	AMEM05/6	Item Foreign Language Descriptions	AMVCBDFR
	Inquiry	AMEM02/1	Display Item Detail
AMEM02/2		Product Structure Retrievals	AMEM0202
AMEM02/3		Single Level Costed	AMEM0203
AMEM02/4		Routing	AMEM0204
AMEM02/5		Production Facility	AMEM0205
AMEM02/6		Feature/Options	AMEM0206
AMEM02/7		Feature/Options with S-Number Build	AMEM0207
AMEM02/8		Item Foreign Language Descriptions	AMEM0208
File Maintenance	AMEM04/7	Item Cost Percent Change	AMEM0407
	AMEM05/2	Product Structure	AMEM0502
	AMEM05/3	Production Facility	AMEM0503
	AMEM05/4	Routing	AMEM0504
	AMEM05/9	PDM Control File	AMEM0509
	AMEM06/1	Calculate Cumulative Yield	AMEM0601
	AMEM06/2	Calculate Adjusted Quantity Per	AMEM0602
	AMEM55/1	Item Master	AMEM5501
	AMEM55/2	Product Structure	AMEM5502
	AMEM55/3	Production Facility	AMEM5503
AMEM55/4	Routing	AMEM5504	
Reports	AMEM03/2	Production Facility Report—by Facility	AMEM0302
	AMEM03/3	Production Facility Report—by Dept.	AMEM0303
	AMEM03/4	Feature/Options Report	AMEM0304
	AMEM03/5	Retrieval Selections—Regular	AMEM0305
	AMEM03/6	Retrieval Selections—Costed	AMEM0306
	AMEM03/7	WIP Cost Worksheet	AMEM0307

Security area	Menu/option	Description	Task ID
Costing	AMEM04/1	Product Costing—Current	AMEM0401
	AMEM04/2	Product Costing—Standard	AMEM0402
	AMEM04/3	Product Costing—Both	AMEM0403
	AMEM04/4	Simulate Product Cost—Current	AMEM0404
	AMEM04/5	Simulate Product Cost—Standard	AMEM0405
	AMEM04/6	Simulate Product Cost—Both	AMEM0406
	AMEM04/8	Change L/O Costing Table	AMEM0408
	AMEM04/9	Change L/O Simulation Costing Table	AMEM0409
	AMEM04/10	Change P/O Costing Table	AMEM0410
	AMEM04/11	Change P/O Simulation Costing Table	AMEM0411
	PDM Code File Maintenance	AMEM59/1	Bill of Lading Commodity
AMEM59/2		Country	AMVAJDFR
AMEM59/3		Item Class	AMVBADFR
AMEM59/4		Item Price Class	AMVBDDFR
AMEM59/5		Item Sales Family	AMVCHDFR
AMEM59/6		Item Sales Group	AMVCIDFR
AMEM59/7		Language	AMVBEDFR
AMEM59/8		Transaction Unit of Measure Class	AMVBJDFR
AMEM59/9		Unit of Measure Master	AMVBKDFR

Appendix C. Information retrieval and calculations

This appendix shows you how information is retrieved and calculations are performed in PDM.

Retrieval logic

Single level explosion routine

This routine is the basis for all explosions. It retrieves the direct components (subassemblies and simple parts) that make up an assembly. The printed output is often called a parts list or bill of material.

All of the Product Structure records associating components to a parent have a common primary key field in the Product Structure file, parent item number. Reading all of the Product Structure records with a common parent item number provides the single level bill of material for that parent item number. Descriptive information for the parent item and all of its components is stored in the Item Master file.

Indented explosion routine

The output of this routine shows the level-to-level breakdown of an assembly to its lowest level. The output can be indented to indicate the level of the component relative to the assembly being exploded. This explosion is a series of interrupted single level explosions. Whenever a component is, in turn, an assembly, the explosion of its parent is stopped, and the component is exploded. In this way, what may be called the vertical (from level to level) explosion of an assembly takes precedence over its horizontal (within one level) explosion. When the explosion of a component leads to no new explosions, the explosion of its parent is continued. In this way, the explosion may go down and up the product structure many times. This has the effect of showing how the initial assembly is constructed from top to bottom.

Summarized explosion routine

Summarized quantities of items within an assembly are obtained by exploding the assembly, using the indented explosion routine and, by creating and updating summary work file records, extending and adding quantity totals for each item as it is encountered in the indented explosion.

Single level explosion with blow-through routine

This routine retrieves the direct components of an assembly and shows or prints them as is done in the single level explosion routine.

If a direct component is a feature, the single level explosion of the parent is interrupted. A single level explosion is performed on the feature's assembly so that the options for the feature are shown. This is referred to as a blow-through of the feature. Once the single level explosion for the feature is complete, the interrupted explosion of the parent is resumed.

If a direct component of the parent is a phantom, the single level explosion of the parent is interrupted. A single level explosion is performed on the phantom's assembly showing all direct components of the phantom. If a phantom has a phantom as a direct component, the component's single level bill is also shown. The maximum levels of phantoms exploded (with their direct components shown) is 99.

This is referred to as a blow-through of a phantom. Once the phantom blow-through is complete, the interrupted explosion of the parent is resumed.

Single level implosion routine

This routine is the basis for all implusions. It retrieves all of the assemblies in which the item is used as a component directly.

All of the Product Structure records associating parents to a component use the component item number as a common primary key field in an alternate view of the Product Structure file. Reading all of the Product Structure records with a common component item number provides all of the usages for that component item number. Descriptive information for the component item and all of its parents is stored in the Item Master file.

End-item where-used routine

The end-item where-used implosion provides a list of end items associated with a component. A logical file of the PSTRUC file provides an index by component/parent. This implosion is a series of interrupted single level implusions. The adjusted quantity per for each level is stored in a runtime array, along with the standard batch quantity of each parent item. Each time an end-item is encountered, the extended quantity of the component is calculated and added to a summarized record for the end-item/component relationship. The implosion is performed for all usages of the component throughout the bill of material. All end-items with summarized totals of the extended usage of the component are provided.

The output of this routine shows only end-items on which the component item being imploded is used directly or indirectly.

Routing routine

This routine retrieves the operations that make up an item's routings. All of the Routing records associating routing operations to an item have a common primary key field in the Routing file, item number. Reading all of the Routing records with a common item number provides the operations which make up an item's routings. Additional routing descriptions, if any, and facility information are found in the Routing Description and Production Facility files for each operation.

Production Facility where-used routine

This where-used routine retrieves all the items which have routing operations at a given facility. All the Routing records associating routing operations to a facility have a common primary key field in an alternate view of the Routing file, facility ID. Reading the Routing records with a common facility ID provides all of the items which are associated with that facility. Descriptive information for the items is stored in the Item Master file.

Low-level codes

A low-level code is a number indicating the lowest level or tier at which a particular item can be found in all product structures. A low-level code is set by product structure load maintenance in each Item Master record. Figure 10-1 on page C-3 depicts the product structure trees of top-level assemblies A and K, showing the relative level number of each item, starting with the top level defined as level zero. Figure 10-1 also depicts the low-level codes for each item number.

Low-level codes are used for continuity checking in the Product Structure File Load and Maintenance program AMEB1, and for product costing.

The Product Structure File Load and Maintenance program checks the low-level code each time an assembly component is added to the file during initial loading and subsequent additions. Low-level codes are lowered by incrementing them numerically, if necessary.

Low level codes are not checked or updated when a component is deleted, and they can be regenerated by the Product Structure reorganization procedure.

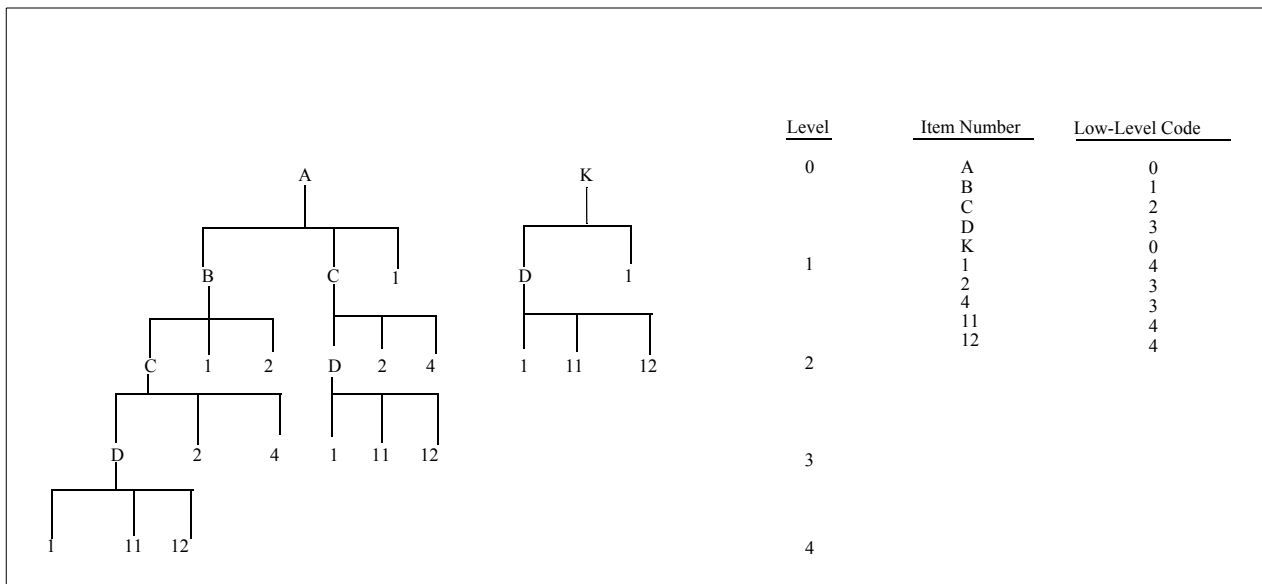

Figure 10-1. Low-level codes

Level tables

A program-built table called a level table is used in the indented and summarized retrievals to capture the key fields in the Item Master and Product Structure records.

A level table, as used by indented retrievals, is shown in Figure 10-2 on page C-4. During the execution of an indented explosion, the explosion of any subassembly may be interrupted at any time because one of its components is, in turn, an assembly and must be exploded. During the execution of an indented implosion, the implosion of any item may also be interrupted at any time because one of its parents has usages and must be imploded. The situation can extend through many relative levels.

The level table for indented retrievals is used to store the key of the Product Structure record that represents either the component of an assembly whose explosion has been interrupted or the usage of an item whose implosion has been interrupted. A relative level index controls the level of the table being used, and the relative level being exploded or imploded is changed by increasing or decreasing the relative level index by one. Each level in the table may be used many times in an indented retrieval.

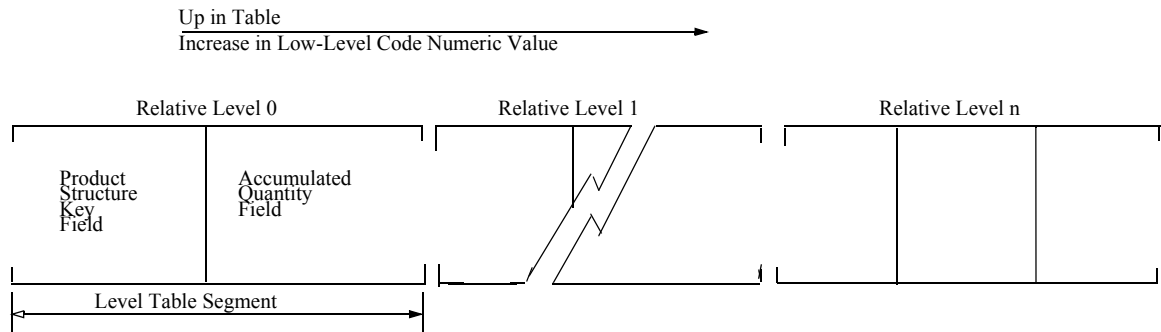

Figure 10-2. Level table as used in indented retrievals

Product structure continuity checking

Maintenance of a large volume of records requires that checks and controls be built into the system. A control required in maintaining product structure records is the verification of continuity in assembly-subassembly breakdowns.

Continuity means the Product Structure file must not contain an assembly that uses itself as a component directly or indirectly (through subassemblies). Figure 10-3 shows the addition of part number B to assembly B. This violates the assembly concept, since an assembly cannot be a component of itself. This is recognized as an error by the Product Structure File Load and Maintenance program (AMEB1).

If Figure 10-3 was altered to indicate the addition of item A (instead of B) to assembly B, there would not appear to be any violation of the continuity rule. However, Figure 10-4 further shows assembly B's position in the product structure tree. It indicates that assembly A contains itself, one level removed, through subassembly B. Only by reflecting each assembly's position relative to other assemblies in the product structure can an assembly be recognized that contains itself at one or more levels removed. This condition is automatically recognized by the low-level code updating procedure. The logic from that procedure is used in this procedure and requires that the low-level code of a component's Item Master record be numerically greater than the low-level code of the parent assembly's Item Master record. If this is not true, the low-level code in the component's Item Master record is made numerically one larger than the parent assembly's low-level code. If the component is a subassembly as well, the low-level code assignment of each of its components must be checked by explosion. The process is repeated until the components of all lower subassemblies have proper low-level codes.

Attempting to add an item to itself directly or indirectly would, if allowed, place the low-level update logic in an endless loop, since the low-level codes would never be large

enough. Figure 10-4 shows the looping condition arising from adding item A to assembly B. The Product Structure file load and maintenance program recognizes the loop and prevents the component causing this error from being added to the assembly.

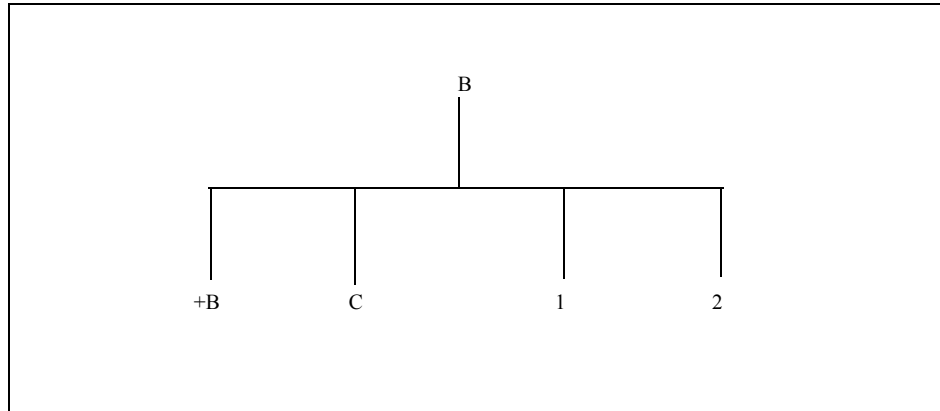

Figure 10-3. Parent assembly number identical to component item number

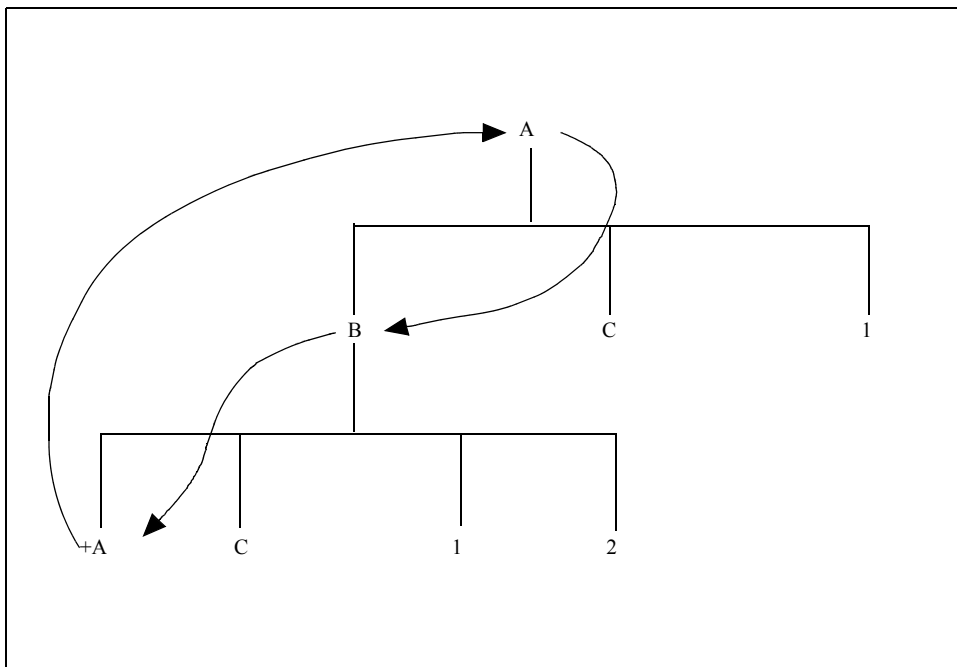

Figure 10-4. Assembly contains itself through a subassembly, resulting in an endless loop when chasing the assembly chain

Cost calculations

Current and standard costs (this level) for an item are calculated using identical formulas, based on Item Master and Production Facility fields. The only difference is that current fields are used to develop current costs, and standard fields are used to develop standard costs.

An item's material, labor, machine, and manufacturing overhead content this level and setup cost per lot are calculated based on the Item type code (ITTYP) and the Cost technique code (CTECH) for the item.

If you selected to use facility standard efficiency during application tailoring, the standard efficiency factor for each facility is used to factor the machine and labor hours which are used to calculate the various cost elements for operations occurring in that facility.

Item type code = 9:

- Material this level remains the value contained in the Item Master record.
- Labor, machine, and overhead content this level are calculated the same way as for a manufactured item.

Purchased item:

- Material this level remains the value contained in the Item Master record.
- Labor, machine, and overhead content this level are normally zero.
- Setup cost per lot remains the value in the Item Master record.

Manufactured item:

- Material this level is calculated during cost roll-up.
- Labor, machine, and manufacturing content this level and setup cost per lot are calculated based on the cost technique code (CTECH):
 - blank** Uses value entered during Item Master maintenance
 - T** Labor hours x labor rate, using the L/O costing table. (The labor hours and the labor rate table code are in the Item Master file.)
 - R** Calculated, based on each active routing operation (see formulas later in this section).

Costs are affected by the following:

- Item Master file cost fields or standard lot size.
- Quantity per in the bill of material (product structure file).
- Labor hours, labor or overhead code in the Item Master file, if CTECH=T.
- L/O costing table rates, if CTECH=T.
- Rates/percentages or efficiencies (if you chose during tailoring) in the Production Facility file, if CTECH=R.
- Hours, amounts, yields, or setup crew size in the Routing file, if CTECH=R
- PDM Control file (defines which elements are used to compute an item's unit cost).

An item's recost flag is reset if the Item Master, Product Structure, or Routing files are changed in the associated fields. You can determine when an item's unit cost is recalculated, by running selective or full, current, standard, or both costing.

Cost formula used for material

All costs described below are "this level" costs:

Material Cost: $(A + B) \times (C/D)$

where:

- A = component material
- B = component purchase overhead
- C = adjusted quantity per
- D = standard batch quantity (of the parent)

Source of data used in Material cost calculations

- Product Structure file: Adjusted quantity per (PDM)
- Item Master file:
 - Material (components)
 - Purchase overhead (components)
 - Standard batch quantity (parent) (PDM)

You define a quantity per when you create a bill of material (during product structure file maintenance). You convert it to an adjusted quantity per, using a menu option in PDM. The yield through all previous operations is divided by the yield for all operations and that number is multiplied by the quantity per to arrive at the adjusted quantity per. Only product structure records with a current effective date are used in the calculations.

Cost formulas used when cost technique code=T

All costs described below are "this level" costs:

- Setup labor: zero
- Run labor: Labor hours (Item Master file) x Labor rate (L/O table)
- Setup machine: zero
- Run machine: zero
- Manufacturing overhead: one of the following:
 1. Labor hours (Item Master file) x Overhead rate (L/O table), or
 2. Run labor (as calculated above) x Overhead percent (L/O table)

Note: A negative value in the Labor/Overhead table indicates that the value is a percentage. A positive value indicates that the value is a rate.

Cost formulas used when cost technique code=R

All costs described below are "this level" costs:

- Time Basis Code: The formulas below should be adjusted by the Time Basis Code for each operation, as follows:

TBC	Description	TBC factor	Comments
1	hours per unit	1.0	
2	hours per 10 units	0.1	
3	hours per 100 units	0.01	
4	hours per 1,000 units	0.001	
5	hours per 10,000 units	0.0001	
M	minutes per piece	1 divided by 60	0.016666667
P	pieces per hour	1 divided by run labor hours	Reciprocal
H	hours per lot	1 divided by standard lot size	Yield is not used
C	cost per piece		Outside operation

For a time basis code of P, the factor used to compute the run labor amount is "1 divided by run labor hours" and the factor used to compute the run machine amount is "1 divided by machine labor hours".

For formulas used when the TBC=C, see "Outside operations".

- Setup Cost per Lot: The routing operation setup cost per lot is:

$$(A \times B) + \{(A \times C) / D\}$$

where:

- A = setup labor hours
- B = setup labor rate
- C = machine rate
- D = setup crew size

All active routing operations are used to compute an item's total setup cost per lot.

Source of data used in Labor and Machine cost calculations

- Routing file:
 - Setup labor hours
 - Setup crew size
- Production Facility file:
 - Setup rate
 - Machine rate

Labor and Machine Costs

Setup Labor Cost: The labor and machine setup cost is:

$$\{(A \times B) / C\} / D$$

where:

- A = Setup labor hours (adjusted by TBC factor, if TBC=M)
- B = Setup labor rate
- C = Standard lot size
- D = Standard efficiency, (if tailored to use)

Run Labor Cost: The run labor cost is:

$$\{(A \times B) \times C\} / D$$

where:

- A = Run labor hours (adjusted by TBC factor)
- B = Run labor rate
- C = Yield adjustment (yield through previous operations/yield all operations)
- D = Standard efficiency, (if tailored to use)

Setup Machine Cost: The setup machine cost is:

$$\{(A \times B) / (C \times D)\} / E$$

where:

- A = Setup machine hours (adjusted by TBC factor, if TBC=M)
- B = Machine rate
- C = Standard lot size
- D = Setup crew size
- E = Standard efficiency, (if tailored to use)

Run Machine Cost: The run machine cost is:

$$\{(A \times B) \times C\} / D$$

where:

- A = Run machine hours (adjusted by TBC factor)
- B = Run machine rate
- C = Yield adjustment (yield through previous operations/yield all operations)
- D = Standard efficiency, (if tailored to use)

Source of data used in Labor and Machine cost calculations

- Item Master file:
 - Standard lot size
 - Yield all operations
- Routing file:
 - Setup labor hours
 - Run labor hours
 - Setup machine hours
 - Run machine hours
 - Setup crew size
 - Yield through previous operations
- Production Facility file:
 - Labor rate
 - Setup rate
 - Machine rate
 - Overhead code
 - Overhead rate/percent
 - Standard efficiency

Note: Yield is not used if TBC=H.

Manufacturing Overhead

Manufacturing overhead calculations use the following elements, which were described previously:

1. Setup labor cost
2. Run labor cost
3. Setup machine cost
4. Run labor cost

Since calculations for those elements use yield and efficiency (if tailored), overhead is also affected by yield and efficiency. The following formulas apply when the TBC is not C (outside operation). For TBC=C there is no manufacturing overhead calculated. When the TBC=C, see "Outside operations" for information on calculating outside operation overhead.

Overhead code = A (Based on machine cost):

$$(A + B) \times C$$

where:

- A = Setup machine cost
- B = Run machine cost
- C = Overhead percent for code A

Overhead code = B (Based on labor cost):

$$(A + B) \times C$$

where:

- A = Setup labor cost
- B = Run labor cost
- C = Overhead percent for code B

Overhead code = C (Based on machine hours per unit):

$$\{(A/(B \times C) + (D \times E)) \times F$$

where:

- A = Setup machine hours
- B = Setup crew size
- C = Standard lot size
- D = Run machine hours, adjusted by TBC factor
- E = Yield adjustment (yield through previous operations/yield all operations)
- F = Overhead rate for code C

Overhead code = D (Based on machine content + (labor hours/units * labor overhead rates)

$$\{(A/B) + C \times D\} \times E$$

where:

- A = Setup labor hours
- B = Standard lot size

C = Run labor hours, adjusted by TBC
 D = Yield adjustment (yield through previous operations/yield all operations)
 E = Overhead rate for code D

Source of data used in Manufacturing Overhead calculations

- Production Facility file: Overhead rate/percent
- Routing file:
 - Setup labor hours
 - Run labor hours
 - Setup machine hours
 - Run machine hours
 - Setup crew size
 - Yield through previous operations
- Item Master file:
 - Standard lot size
 - Yield all operations

Note: Yield is not used if TBC=H.

Outside operations

If the Time Basis Code (TBC) = C for an active routing operation, outside operation cost is calculated. An amount can be entered into either the run machine hours field or into the outside operations field in the Item Master record for an item. In either case, the entry is considered to be the base amount of the outside operation cost, not the hours. Therefore, the machine amount is never multiplied by a rate. Overhead also can be calculated and added to the outside operation cost amount. The value in the run labor field is not used to calculate outside operations cost.

Overhead code = A (Based on machine cost):

$$(A + B) \times C$$

where:

A = Setup machine cost
 B = Run machine amount as entered
 C = Overhead percent for code A

Overhead code = B (Based on labor cost):

$$(A + B) \times C$$

where:

A = Setup labor cost
 B = Outside operation amount (as entered)
 C = Overhead percent for code B

Overhead code = C (Based on machine hours per unit):

$$A \times B$$

where:

- A = Setup hours
- B = Overhead rate for code C

Overhead code = D (Based on labor hours per unit):

A x B

where:

- A = Setup hours
- B = Overhead rate for code D

Source of data used in outside operations calculations

- Routing file:
 - Setup hours
 - Run machine amount
- Production Facility file: Overhead rate/percent

Outside operation cost calculations

Outside operation costs are calculated to be the sum of:

- Outside operation amount (as entered)
- Outside operation overhead (as calculated)
- Setup labor cost (as calculated)
- Run machine cost (as entered)

This value is put into the outside operation field in the Item Master file.

Setup machine cost is calculated and placed into the setup machine field in the Item Master file, for overhead codes B, C, and D. For code A, the setup machine cost is added to the outside operation amount (as entered).

Note: Efficiency is not used, nor is there any time basis code (TBC) adjustment for outside operations.

Cost roll-up logic

An item's unit cost is the sum of the following fields contained in the Item Master record:

- Current and Standard material this level
- Current and Standard outside operations this level
- Current and Standard purchase overhead this level
- Current and Standard setup labor this level
- Current and Standard run labor this level
- Current and Standard setup machine this level
- Current and Standard run machine this level
- Current and Standard manufacturing overhead this level.

The calculation of content this-level fields was discussed previously in “Cost calculations”. For purchased items, and items with item type code of 9, PDM does not roll up costs.

Cost roll-up is a technique to calculate the lower-level content fields and material this level for manufactured items whose item type code is other than 9.

The technique is the same for both current and standard costs, differing only in that current cost fields are used to calculate current costs and standard cost fields are used to calculate standard costs. These fields are calculated as follows:

- Material this level = sum of materials this level of all direct, active components.
- Material lower levels = sum of materials this level and lower levels of all direct, active components.
- Labor lower levels = sum of labor contents this level and lower levels of all components.
- Overhead lower levels = sum of overhead contents this level and lower levels of all components.

Feature/options handling (includes discussion of phantoms)

A feature represents a way for an end-item (an item which has no parents) to define optional structures of itself.

Let's use an example of an automobile (Z) as an end-item. One of Z's direct components is a feature called Engine (E). E's options are: 250 cc, 350 cc, 400 cc, and 450 cc. Another of Z's direct components is a feature called Color C. C's options are: Blue, Red, Yellow, and Grey. The rest of Z's first-level components are subassemblies, purchased parts, fabricated items, raw materials, or phantoms.

Only end-items can have features. End-items with features are prevented from being attached as components to higher assemblies. Features can be specified as required or nonrequired in the product structure relationship.

A 2-digit feature can have up to 1295 options, depending on how the user lays out the Feature/Options Field Size Template (F/O template) in the PDM questionnaire. End-items can have up to 20 features, depending on how many option field size questions the user answered during application tailoring. There is only one F/O template in PDM (FOTAB1). The template has twenty elements, one position each. The only valid content of each element is a 0, 1, or 2. The F/O template is in a record in the SYSCTL file. Its key is FOTAB1.

The F/O Template (an array) is used to overlay an S-number to locate which option was selected for which feature.

The S-number is entered with an end-item when requesting an inquiry or a report. The S-number is a manually entered, nonstored field in which you can specify one option for each feature of the end-item wanted.

To process an S-number, FOTAB1 is retrieved and then each option number is moved serially from the left of the S-number to a work array (20 elements, 2 characters each) for the lengths specified in FOTAB1. The features start at the left with feature 1 and go to the right sequentially.

For example, if FOTAB1 = 11212 and item AX147 is a valid end-item with features, then for a product structure retrieval the following entries:

- Item AX147
- S-number 9393107.

Translate to:

- Item AX147 with
- Feature 1's Option 9
- Feature 2's Option 3
- Feature 3's Option 93
- Feature 4's Option 1
- Feature 5's Option 07.

Features vs. Phantoms

Features can never be stocked because they physically do not exist. A feature is a logical focal point that says here is a place to look for an associated set of options, only one of which may be used.

Phantoms are not usually stocked. A phantom is a group of components that are used in many different products and are treated in each product as though they were listed individually in that product's structure. In Inventory Management (if the phantom has a zero on hand balance) and in the single level mode with blow-through PDM retrieval, when a phantom item is encountered, its components are retrieved and treated as though they were all present in the original single level bill of material.

Features can be components only on the next lower level of an end-item. When product costing is run, costs are rolled up for phantoms as for any other assembly. However, since only one option at a time is possible for a feature, the feature's costs are a weighted average of all its options. This is done using the cost roll-up factor in each feature/option Product Structure record.

Phantoms can be on any level in a product structure and can be in the structure of another phantom. PDM supports phantoms on phantoms for 99 levels.

Features have options which are selectively retrieved using S-numbers.

Phantoms do not have options and therefore do not use S-numbers.

Note: FOTAB1 is established during application tailoring. It is not maintained by application programs.

Appendix D. Automated job submission for PDM

XA provides the ability to execute XA batch jobs from outside of the XA menu structure for Product Data Management (PDM) application tasks listed below:

Task	Menu and Option	Command
Item Master Offline Maintenance	AMEM55-01 and AMIM7E-01	OLMITM
Product Structure Offline Maintenance	AMEM55-02	OLMPST
Routing Offline Maintenance	AMEM55-04	OLMRTG

XA provides the necessary architecture modules to enable application tasks to be initiated from sources other than the XA menu system and to be initiated in a batch subsystem. In order to provide the most flexibility, the Cross Application Support (CAS) portion of this activity should be done using a series of Application Program Interfaces (APIs). These CAS APIs then can be used by the applications to provide a programmer's interface to each batch job. The end user cannot execute these APIs on the eSeries command line; they must be called by a batch or interactive program.

Refer to the *CAS Technical Reference Guide* for more information on the APIs and for a list of all the application tasks available.

Command guidelines

This section is intended to provide assistance when you are formulating the name for an XA command. XA command names are patterned after the eSeries Control Language Standard. This provides an action-object naming structure. Command names are usually composed of a series of three-character abbreviations. The maximum length for a command name is ten characters.

It is acceptable to use the XA application abbreviation in a command name even though some applications have two- or four-character abbreviations. Using the application abbreviation may be necessary to distinguish between printing a REP or COM pick list, for example.

The following lists are only examples of the abbreviations you might choose to use. You can define your own abbreviations for your company.

Action abbreviations:

ADD	Add
CHG	Change
CLR	Clear
CRT	Create
DLT	Delete
DSP	Display
MNT	Maintain
OLM	Offline Maintenance
PRT	Print
SBM	Submit
WRK	Work with

Object abbreviations:

CLN	Component/Line Definition
HRZ	Horizon
ILN	Item/Line Definition
ITM	Item
LOC	Location
OPT	Option
PKL	Pick List
PLN	Plan or Planning
PRL	P.O.Auto Release
PST	Product Structure
REL	Release
RTG	Routing
TGL	Temporary General Ledger
TXR	Transaction Register
USR	User
WHS	Warehouse

Application APIs

The application APIs are shipped in the form of eSeries commands. The application command may be named OLMxxxxyy, where xxxyyy is unique to each job. For example, the Offline Product Structure Maintenance command may be named OLMPST.

The Offline Product Structure Maintenance command requires a user to enter the offline file name to be used. After being automated, the OLMPST command could be used from a menu

```
OLMPST PROMPT(*YES)
```

The command also can be used as part of a System i job, using a user-written CL program similar to this example illustrating the OLMPST command. The STRXAENV and ENDXAENV commands are required.

```
PGM
STRXAENV ENDS (NN)
OLMPST PROMPT(*NO) ENDS(NN) FILE(PSEDIT)
ENDXAENVS
ENDPGM
```

If the application task being automated supports interactive prompts, the command would support a prompt parameter in addition to the application parameters required to run the job. The purpose of the prompt parameter is to instruct the application to display the prompt screens or to use the parameter values associated with the command. The prompt parameter has values of *YES and *NO. If the prompt parameter is *YES, the application parameters cannot be specified on the command.

Each application command supports a parameter to designate the XA execution environment. The environment designator is used to validate that the function is being executed in the proper XA environment. Requiring this parameter serves as a precautionary measure to prevent functions from being inadvertently executed against the wrong environment. The environment designator will only be required and validated when the application command is executed with a PROMPT value of *NO.

More detail about the PDM APIs appears on the following pages.

OLMITM - Offline Item Maintenance

```

Offline Item Maintenance (OLMITM)

Type choices, press Enter.

Prompt at run-time . . . . . > *NO_      *YES, *NO
XA environment . . . . .      _         Character value
Processing option . . . . . *EDIT_     *EDIT, *UPDATE
Offline file name . . . . .      _         Name
  Library . . . . .          *LIBL_     Name, *LIBL
Retain offline transactions . . *ALL_     *ALL, *ERRORS, *NONE

                                                    Bottom
F3=Exit  F4=Prompt  F5=Refresh  F12=Cancel  F13=How to use this display
F24=More keys
    
```

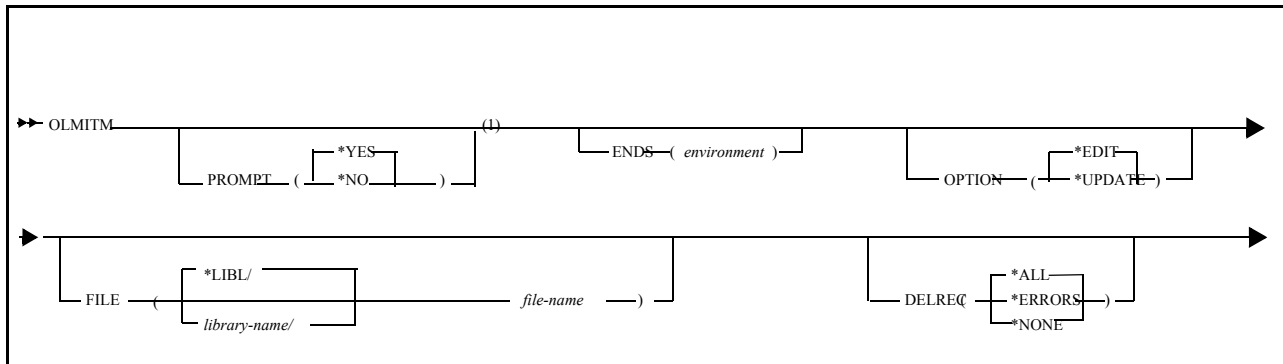

Purpose

The Offline Item Maintenance (OLMITM) command is used to process a file containing offline item maintenance transactions. Information regarding the layout of the transactions can be found in an appendix of the application user's guide.

Optional Parameters

- PROMPT** Specifies whether the function should prompt for the application values at run-time.
- *YES** Application should prompt user for run-time values.
- *NO** Application should use run-time values supplied by command.

- ENDS** Specify the XA environment designators to be validated when executing the command. If the environment designator specified here does not match the environment designator associated with the current eSeries job, this function will not execute. This will stop functions from inadvertently being executed against the wrong XA environment.
- OPTION** Specifies how the application should process the offline transactions.
 - *EDIT** Transactions are only edited.
 - *UPDATE** Transactions are edited and the database is updated.
- FILE** Specifies the name of the file containing the offline transactions.

The possible library values are:

 - *LIBL** The library list is used to locate the file name.
 - library-name** Specify the name of the library where the file is located.
 - file-name** Specify the name of the file to be processed
- DELREC** Specifies what offline transactions should be retained after the file has been processed.
 - *ALL** All transactions should be retained.
 - *ERRORS** Only error transactions should be retained.
 - *NONE** No transactions should be retained.

OLMPST - Offline Product Structure Maintenance

```

Offline Product Structure Mnt (OLMPST)
Type choices, press Enter.

Prompt at run-time . . . . . > *NO_          *YES, *NO
XA environment . . . . . _____          Character value
Processing option . . . . . *EDIT_          *EDIT, *UPDATE
Offline file name . . . . . _____          Name
Library . . . . . *LIBL_____          Name, *LIBL
Retain offline transactions . . *ALL_____ *ALL, *ERRORS, *NONE

                                           Bottom
F3=Exit  F4=Prompt  F5=Refresh  F12=Cancel  F13=How to use this display
F24=More keys
```

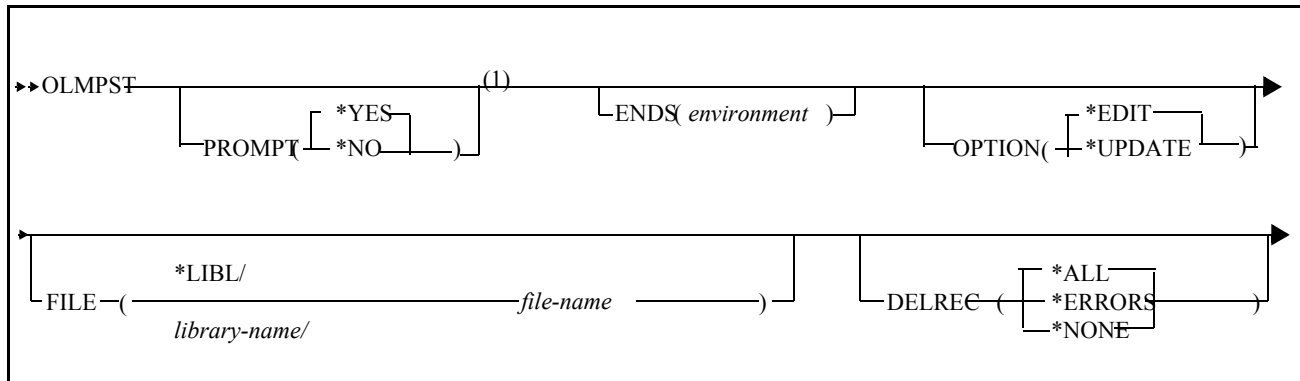

Purpose

The Offline Product Structure Maintenance (OLMPST) command is used to process a file containing offline product structure maintenance transactions. Information regarding the layout of the transactions can be found in an appendix of the application user's guide.

Optional Parameters

- PROMPT** Specifies whether the function should prompt for the application values at run-time.
 - *YES** Application should prompt user for run-time values.
 - *NO** Application should use run-time values supplied by command.

- ENDS** Specify the XA environment designators to be validated when executing the command. If the environment designator specified here does not match the environment designator associated with the current eSeries job, this function will not execute. This will stop functions from inadvertently being executed against the wrong XA environment.

- OPTION** Specifies how the application should process the offline transactions.
 - *EDIT** Transactions are only edited.
 - *UPDATE** Transactions are edited and the database is updated.

- FILE** Specifies the name of the file containing the offline transactions.

The possible library values are:

 - *LIBL** The library list is used to locate the file name.
 - library-name** Specify the name of the library where the file is located.
 - file-name** Specify the name of the file to be processed.

- DELREC** Specifies what offline transactions should be retained after the file has been processed.
 - *ALL** All transactions should be retained.
 - *ERRORS** Only error transactions should be retained.
 - *NONE** No transactions should be retained.

OLMRTG - Offline Routing Maintenance

```

Offline Routing Maintenance (OLMRTG)
Type choices, press Enter.

Prompt at run-time . . . . . > *NO_          *YES, *NO
XA environment . . . . .                Character value
Processing option . . . . . *EDIT_         *EDIT, *UPDATE
Offline file name . . . . . _____      Name
Library . . . . . *LIBL_____           Name, *LIBL
Retain offline transactions . . *ALL_     *ALL, *ERRORS, *NONE

F3=Exit  F4=Prompt  F5=Refresh  F12=Cancel  F13=How to use this display
F24=More keys
    
```

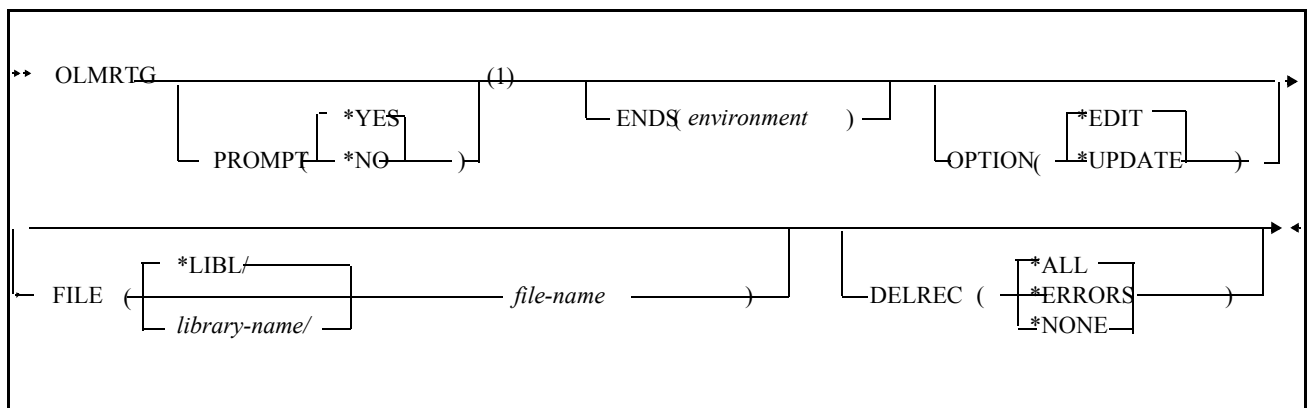

Purpose

The Offline Routing Maintenance (OLMRTG) command is used to process a file containing offline routing maintenance transactions. Information regarding the layout of the transactions can be found in an appendix of the application user's guide.

Optional Parameters

- PROMPT** Specifies whether the function should prompt for the application values at run-time.
 - *YES** Application should prompt user for run-time values.
 - *NO** Application should use run-time values supplied by command.

- ENDS** Specify the XA environment designators to be validated when executing the command. If the environment designator specified here does not match the environment designator associated with the current eSeries job, this function will not execute. This will stop functions from inadvertently being executed against the wrong XA environment.
- OPTION** Specifies how the application should process the offline transactions.
- *EDIT** Transactions are only edited.
 - *UPDATE** Transactions are edited and the database is updated.
- FILE** Specifies the name of the file containing the offline transactions.
- The possible library values are:
- *LIBL** The library list is used to locate the file name.
 - library-name** Specify the name of the library where the file is located.
 - file-name** Specify the name of the file to be processed.
- DELREC** Specifies what offline transactions should be retained after the file has been processed.
- *ALL** All transactions should be retained.
 - *ERRORS** Only error transactions should be retained.
 - *NONE** No transactions should be retained.

Glossary

This glossary defines terms that are important for this application. It does not include all XA terms nor all terms established for your system. If you do not find the term you are looking for, refer to the Index in this book, to glossaries in other XA publications, or to the IBM Dictionary of Computing, SC20-1699.

This glossary includes definitions from:

- *The American National Dictionary for Information Processing Systems*, copyright 1982 by the Computer and Business Equipment Manufacturers Association (CBEMA). Copies may be purchased from the American National Standards Institute, 1430 Broadway, New York, New York 10018. Definitions are identified by symbol (A) after definition.
- *The ISO Vocabulary – Information Processing and the ISO Vocabulary – Office Machines*, developed by the International Organization for Standardization, Technical Committee 97, Subcommittee 1. Definitions of published sections of the vocabulary are identified by symbol (I) after definition; definitions from draft international standards draft proposals, and working papers in development by the ISO/TC97/SC1 vocabulary subcommittee are identified by symbol (T) after definition, indicating final agreement has not yet been reached among participating members.

additional routing operation description. See routing operation description.

adjusted quantity per. The quantity of the component item required to make a standard batch quantity of the parent item. This number includes adjustment for operation yield. See also quantity per and standard quantity per.

allocation. 1. The process of offsetting transaction allocation balances (typically cash and credit notes) against transaction settlement balances (typically invoices). 2. The reserving of available inventory for a requirement, such as an explicit open production order. See discrete allocation.

alphanumeric. Pertaining to a character set that contains letters, numbers, and usually other characters, such as punctuation marks and mathematical symbols. Synonymous with alphameric. (A)

alternate item. A user-defined identifier for an item. For example, it could be an OEM number or UPC code. This is used by Electronic Commerce (EC).

application. The use to which an information processing system is put, for example, a payroll application, an airline reservation application, a network application.

application tailoring. The process of selecting, using a Questionnaire, the application options that satisfy the specific needs of a company.

assembly. The combination of two or more items to make a new item.

audit trail. 1. Data, in the form of a logical path linking a sequence of events, used for tracing the transactions that have affected the contents of a record. (T) 2. Information that allows you to trace the history of an account, item record, order, and so forth. The more recent information may be stored online so you can retrieve it

available. The net quantity of material on hand, plus the quantity on order, minus the quantity reserved for specific purposes.

average cost. The cost of each piece of an item in inventory, arrived at by dividing the total value of the item by the number of pieces in inventory.

batch. 1. An accumulation of data to be processed, as in batch of transactions. 2. A group of jobs to be run on a computer at one time with the same program.

batch/lot number. The field allowing unique identification of a specific batch or lot of an item. When an item is defined as having batch/lot control, all transactions involving that item must carry the batch/lot number.

batch update. The process of updating master files using a group of transactions that are being held in a transaction file. Contrast with interactive and online update.

bill of material. A list of raw materials or components and the quantities needed to make an item, assembly, or end product.

bill of material structuring. The method used to describe the assembly of end products with single-level bills.

blow-through. Used only in reference to a single level Product Structure retrieval. It means that when a retrieval shows the single level of the direct components for a specified parent item that has any component which are features or phantoms, it then drops down a level (blow-through) for that component only to show its components (options for features or components for phantoms).

capacity. A measure equipment, resource, space, and operating speed used to handle orders released to the shop floor.

character. A member of a set of elements that is used for the representation, organization, or control of data. Characters may be letters, digits, punctuation marks, or other symbols. (T)

close. To end the processing of a file.

command. A request from a terminal for performance of an operation or execution of a program.

component. An item used to make a higher-level item.

configuration. The group of machines, devices, and programs that make up a data processing system.

critical item. In material requirements planning, an item that has a longer than normal lead time, or an item whose scarcity may limit production. See also lead-time.

cumulative yield. The percentage of the parent item completed through the last operation compared to the quantity originally put into production.

current cost. Latest expected cost derived from engineering standards (material and labor) in association with current labor and overhead rates. Also called current standard cost.

current operation yield. A percentage of the expected parent quantity at the end of a routing operation compared to the quantity at the beginning of an operation based on the current environment.

current standard cost. See current cost.

data. A representation of facts, concepts, or instructions in a formalized manner suitable for communication, interpretation, or processing by humans or automatic means. (I) (A)

data base. A set of data, part or the whole of another set of data, that consists of at least one file, and that is sufficient for a given purpose or for a given data processing system. (I) (A)

data entry. The process of putting data onto a machine-readable medium; for example, to enter data into payroll file on a flexible disk from terminal. (T)

dedicated. Pertaining to a mode of operation in which a procedure requires all the resources of the system.

default. Pertaining to an attribute, value, or option that is assumed when none is explicitly specified. (I)

delete. To remove an object or unit of data such as a character, field, or record.

discrete order quantity. A rule for determining order size using the period's net requirements as a lot size.

display. A visual presentation of data. (I) (A)

distribution. The assignment of costs or revenue to the various accounts affected.

due date. 1. The date on which, according to the terms and the date of the invoice, payment must be made. 2. The date by which the work on a shop order is to be completed or a purchase order is to be received.

effective date from. The date an engineering change is designated to become effective.

effective date to. The date an engineering change is no longer effective.

efficiency factor. The ratio of standard to actual hours of work performed in a facility; for example, 98 standard hours divided by 90 actual hours equals 1.09 efficiency factor. It is used to modify labor standards.

end item. The product shipped to the customer.

engineering change. A change made to an item to reduce its cost or improve its function, serviceability, or safety.

enter. To type in information on a keyboard and press the Enter key to send the information to the computer.

entry date. The date on which a transaction is entered into a master file.

explosion. A view of a product structure from the top down. The calculation of how many of each of the items listed in a bill of material are required to produce a given quantity of the item or product represented by the bill. For example, if 500 of product A are required and A is composed of two Bs, three Cs, one D, and four Es, the explosion determines that 1000 Bs, 1500 Cs, 500 Ds, and 2000 Es are needed.

fabricated part. An item manufactured, made, or worked on as opposed to an item assembled or put together.

facility stock location. The location where components are stored for this work station facility.

feature. The options of an end item are grouped by feature. A feature can only have end items as parents and options as components. An end item can have multiple features and a feature usually has multiple options.

field. In a form, display or record, a specified area used for a particular category of data; for example, an area on a display that is regularly used to show an item number.

file. A named set of records stored or processed as a unit. (T)

finished goods. Items ready for shipment to a customer, including parts reserved for service.

firm planned order. An order whose date and quantity have been fixed, but for which no paperwork authorizing production has been released and components have not been allocated.

fixed order quantity. A rule for determining order size that assigns a fixed quantity to all planned orders.

forecast. An estimate of customer (independent) demand for an item for a specific period in the future.

forward scheduling. The technique of beginning with an order start date and adding planned queue time to determine the start date of the first operation. The subsequent operation start dates are determined by adding setup and run time (modified by efficiency factor) for the previous operation plus queue time at this operation.

full costing. In PDM, full costing recosts the current and standard costs (or both) of all items. See product costing, selective costing, simulation.

gross requirement. The required quantity of an item from all sources, such as higher-level subassemblies or the master production schedule.

hash total. A control total, accumulated manually from a batch of input documents, that helps ensure that entry of data into the computer system is correct and documents are not lost. Hash totals can be kept on quantities, part number, invoice number, and so on.

historical standard cost. See standard cost.

IFM. International Financial Management.

inquiry. 1. A request for information in storage. 2. A request for information that puts the system into inquiry mode.

inspection. The examining of completed production or purchased items to see that parts meet tolerances and that work has been properly completed. It may or may not be a separate operation.

interactive. Pertaining to a program or system that alternately accepts input and then responds. An interactive system is conversational, that is, a continuous dialog exists between user and system. Contrast with batch.

interface. 1. The hardware and programs that permit exchange of information between computer systems or among devices. 2. The facility to allow information to pass from one application to another.

item. Any raw material, manufactured, or purchased part, subassembly, assembly, or end item. (Note: although features and phantoms have records in the Item Master file, they exist for logical convenience only; a feature does not physically exist and although a phantom physically exists, it is almost never stocked.)

item data. Data describing products, the component parts and raw materials from which they are made, the bill of material, and the routing indicating the manufacturing process.

item sales group. A user-defined sales group assigned to an item.

item tax class. The tax classification of an item which allows you to group items for tax purposes by tax code.

job. 1. A unit of work for a computer; for example, a payroll job. 2. One or more related procedures or programs grouped into a first-level procedure.

job queue. A list of jobs waiting to be processed

kit. Usually a group of loose components handled as an assembly.

lead-time. 1. The number of days, weeks, or months needed to place an order, process it, and receive the material into inventory. 2. An estimate of the time required in the shop from order release to availability.

level. A relative point in the assembly process where components are added. Levels help describe assembly dependencies. A level-0 assembly is shipped to the customer. Raw material is the lowest level (highest level number) in a company's bill structure.

line item. An individual entry on a voucher.

load. 1. To enter data or programs into storage; for example, to load a master file. 2. The amount of capacity requirements for manufacturing facilities (usually by time period) based on the master production schedule, the material requirements plan, and standard operating times.

loading. The procedure for determining capacity requirements for manufacturing facilities based on the master production schedule.

lot sizing. The procedure for determining the planned order quantities from a schedule of net requirements.

manufacturing order. 1. An order issued to the factory to produce a component or assembly. 2. A number that identifies a manufacturing or assembly order.

margin. The difference between average selling price and projected estimates of current costs.

master file. A file that is used as an authority in a given job and that is relatively permanent, even though its contents may change. (I) (A)

master level. The level in a tree structure bill at which the master production schedule items appear. It is usually either level 0 or 1, depending on the type of product.

master production schedule (MPS). A statement of how many of what items (products and options specified by customers) are planned to be produced and when. It is the major control point for planning the level of manufacturing activity. The master production schedule is one of the major inputs to material requirements planning.

material requirements planning (MRP). The technique of planning the acquisition of items required to produce products stated in a master production schedule.

milestone group. A series of operations for which activity is reported at the last operation.

milestone operation. The last operation in a milestone group.

milestone sub-operation. Any of the individual operations in a milestone group.

mode. A method of operation; for example, enter/update mode.

MRP. Material Requirements Planning.

nature. An account or revenue/expense code.

net requirements. The requirements remaining after on-hand and released orders have been subtracted from gross requirements.

online. Controlled by, or communicating with, a computer.

online update. The process of updating master files immediately upon receiving a transaction from a work station. Contrast with batch update.

operation. A manufacturing or assembly procedure performed on an item. A routing defines the sequence of several operations.

operation sequence number. A number assigned to an operation which defines the sequence within a routing.

operation yield. The percentage of the expected parent quantity at the end of an operation compared to the quantity at the beginning of an operation.

option. In PDM, an option is an item that is one of many items directly related to a feature. An end item can have many options and similar options are categorized in groups called features. For example, the option red could be included under the feature color. To see an end item on a report or inquiry with its specific options shown, you must know which features contain which options. When you request that end item, you can also specify the specific option you want by entering them using the S-number. See S-number.

order point. A quantity which is the sum of forecast demand through replenishment lead time plus safety stock.

order policy code. A code that specifies a lot-sizing technique, such as discrete, fixed order quantity, order up to quantity, and part-period balancing.

order quantity. A quantity to be ordered when issuing a replenishment order. See also lot sizing.

order release. 1. In order processing, authorization to fill a customer's order. 2. In manufacturing, authorization to assemble or fabricate a product identified by a shop order.

overhead costs. All costs that cannot be applied directly to an item (shop order).

overhead rate. A factor to be applied to direct labor cost; it is used to recover (or distribute) overhead costs.

paging. Viewing the records in a file in sequence on a work station. Using this facility, you can read through an entire file rather than seeing one record, as when using inquiry.

parent. An item that has an assembly (components).

part-period balancing (PPB) . A lot-sizing technique that attempts to minimize the sum of the cost of carrying inventory and the cost of acquiring inventory.

phantom bills. Subassemblies that are automatically fed to a higher-level assembly without intermediate stocking. Their use is not considered a level of production.

picking list. A list of items to be taken from stock.

planned order. An order, which specifies delivery date and quantity, developed in a material requirements planning system. It should become a firm order when the order release date on the schedule is within the cumulative material lead time. It is used to plan lower-level component requirements or capacity requirements. A planned order is not committed to the vendor or shop floor until it is released.

PPB. Part-period balancing.

post to future schedule. Code that indicates how you want to apply RM, RO, and SM transaction quantities. The valid codes are blank, 0, or 1.

post to oldest schedule. Code that indicates how you want to apply RM, RO, and SM transaction quantities. The valid codes are blank, 0, or 1.

pre-approved. A code to indicate if this is an item that can be ordered from the vendor without waiting for approval. This code is used only if you are using the approval process for purchase orders and requisitions.

prime load code. Used in calculating the length of an operation for the forward scheduling routine in PC&C. It identifies the critical operation time factors necessary to schedule an offset for each operation's due from its operation's start date.

process sheet. 1. Documentation stored near the facility that describes in considerable detail the operation to be performed 2. Synonymous with routing.

product costing. A method of establishing standard costs (both current standard and historical standard) by using the bill of material to calculate and roll up purchase, labor, and overhead to the end item level. See current cost, standard cost, full costing, selective costing, simulation.

product structure. Links together the Item Master records required to describe a bill of material.

production control. The functional area of the business responsible for the day-to-day scheduling of plant-floor resources. Shop order release, expediting, and order tracking are the primary responsibilities of this area.

production facility. A facility can be either a work center, production line, or work station. A facility is a group of machines with similar characteristics that are used to perform a manufacturing process; for example, an assembly area or milling machine center. It describes the area (group of workers or machines) in which the operations contained in the Routing file are performed. You can have run machine, run labor, setup labor, and overhead standard rates associated with it.

production line. A series of pieces of equipment dedicated to the manufacture of a specific number of products or families.

prompt. A displayed symbol or message that requests input from the user or gives operational information.

purch commodity. The code defined by your company that identifies the purchase commodity classification for an item.

quantity. The number of batches of the standard batch quantity. This number is used to extend (multiply by) the quantity per for each product structure relationship.

quantity per. The quantity of a component item required to make a standard batch quantity of the parent item.

queue. 1. A waiting line or list formed by items in a computer system waiting for service; for example, jobs to be performed. 2. To arrange in or form a queue. 3 In manufacturing planning systems, the backlog of work waiting to be processed at a facility.

receipts. 1. Merchandise or stock that is received in inventory. 2. Cash received.

record. 1. A set of data treated as a unit. (T) For example, one line of an invoice could constitute a record. 2. To store data on a reusable input/output medium, such as a disk, diskette, or punched cards.

reference number. In data entry, a number used for starting a batch or selecting an existing batch.

release. 1. To authorize an order commitment by changing a planned order into a purchase order or shop order. 2. To specify a date and quantity to be shipped under a blanket order.

retrieval. Refers to finding and retrieving (chasing chains) structures or routings for a specific item from the Product Structure or Routing files.

routing. The sequence of operations or processes required to make a manufactured item. Must identify facilities and can have run machine, run labor, setup labor, and overhead standard hours associated with it.

routing operation description. A record providing descriptive information about a manufacturing routing in addition to that contained in the original routing record. Multiple records can be used. Also called additional routing operation description.

run time. The elapsed time an item is actually being worked on in a machine center. It is calculated, at standard, by multiplying order size by time per piece.

run-time option. A specification, made when a computer job is run, that tells how the job is to be run.

SAE. Same-as-except.

safety stock. The quantity of an item carried in excess of expected demand to meet unexpected increases in demand.

same-as-except. The issue of a current bill or material or routing, with minor modifications, to create a new bill or routing for a similar end item.

scrap. 1. The unusable by-product from an operation or a ruined part or assembly that cannot be used in later production. 2. To separate ruined or unusable parts from the current production lot and report the quantity set aside.

selective costing. In PDM, selective costing calculates the current and standard costs (or both) of selected items without changing the costs of items whose costs have already been established. See product costing, full costing.

session. The period of time during which a user of a terminal can communicate with an interactive system, usually, elapsed time between logon and logoff.

setup. The procedure (costs) associated with getting a production facility (machine) ready to produce a new item. The procedure is not dependent on the number of items to be produced. For the sake of simplicity, the costs of removing the setup are usually included.

shrinkage factor. A percentage used to increase the quantity on a planned or released shop order to allow for scrap. An alternate method is to use it to increase gross requirements.

simulation. In PDM, a method of simulating product costing to see the effect on product cost made by changes to the Labor/Overhead Simulation Table or by

changes to the cost fields in the Item Master, Production Facility, Product Structure, and Routing files. See product costing.

S-number (Select-number). Indicates the set of options you want for this end item for this retrieval. The S-number has a field length of 20 and is only seen on the Product Structure retrieval displays only if features and options are installed. One option number for each feature for a specific end item can be entered in the S-number. The option numbers in the S-number correspond by location to the field size template you established during application tailoring.

standard batch quantity. A quantity of the parent item relative to the quantity of each component item. The product structure (recipe or formulation) is expressed in relation to a batch quantity of the parent item as opposed to a quantity of one stocking unit.

standard cost. A base standard cost that usually remains constant for twelve months and is used to measure cost changes. Also called historical standard cost.

standard operation yield. A percentage of the expected parent quantity at the end of an operation compared to the quantity at the beginning of an operation based on the projected "annual standard."

system date. The date assigned by the system operator during the initial program load procedure. Generally, the system date is the same as the actual date.

transaction. An exchange between a work station and another device that accomplishes a particular action or result; for example, the entry of a customer's deposit and the updating of a customer's balance. An item of business, such as receipt of an order or paying a bill.

transaction register. A list of transactions--issues, receipts, and adjustments--affecting the balance of material on hand.

unit of measure. A code indicating the measurement basis for inventory, such as each, pound, tons, gallons, feet.

unit price. The price per standard unit of a product or service.

update. To modify a master file with current information according to a specified procedure.

user ID (user identification). 1. A special ID assigned to you only if you use security. It is not the security password. This ID appears on report headings with the label OPER if you use security. 2. A string of characters that uniquely identifies a user to a system.

user sequence. The user-designated sequence number, together with the component item number, is used to establish the sequence of the bills of material.

validation. Used with chain validation, it verifies that all chains or pointers in a direct file are valid.

vendor. A seller and deliverer of goods or services.

voucher. A document that verifies a transaction, usually indicating the accounts that are affected.

warehouse stock location. The identification of the physical location of inventory storage.

where-used. A report or inquiry showing what higher-level assemblies use an item (the next level or all levels) or what operations are performed in what facilities. It is a tool for maintaining the engineering and production data base.

work station. 1. A device that lets a person transmit information to or receive information from a computer, or both, as needed to perform his job; for example, a display station or a printer. 2. A group of machines with similar characteristics that are used to perform a manufacturing process; for example, an assembly area or milling machine center. It describes the area (group of workers or machines) in which the operations contained in the Routing file are performed.

Index

A

- accounting controls and audits
 - file maintenance 6-3
 - Item Master edit/load 10-1
 - Item Master edit/load reports 10-1
 - Item Master file maintenance 10-9
 - Item Master file maintenance reports 10-9
 - percent changes 10-20
 - percent changes report 10-20
 - Product Structure edit/load 10-4
 - Product Structure edit/load report 10-4
 - Product Structure file maintenance 10-10
 - Product Structure file maintenance reports 10-10
 - Product Structure file reorganization 10-17
 - Production Facility file maintenance 10-12
 - Production Facility file maintenance report 10-12
 - Routing Description file reorganization 10-19
 - Routing edit/load 10-5
 - Routing edit/load reports 10-5
 - Routing file maintenance 10-14
 - Routing file maintenance reports 10-14
 - Routing file reorganization 10-18
 - Variable Capacity File Maintenance 10-13
 - Variable Capacity Master File Maintenance report 10-13
- accounting controls and audits Production Facility file maintenance 6-85
- active batch 2-1
- adding
 - additional routing descriptions 6-121
 - additional routing descriptions (SAE) 6-137
 - component items to product structures 6-35
 - milestone group 6-123
 - milestone group (SAE) 6-140
 - production facility record 6-76
 - routing operation 6-106
 - routing operation (SAE) 6-133
 - SAE component items 6-60
 - variable capacity record 6-89
- adjusted quantity per 2-29
- adjusted quantity per, calculating 7-3
- adjusted run hours 2-30
- AMDPDM1–Control File Maintenance (Page 1 of 3) display 6-191
- AMDPDM2–Control File Maintenance (Page 2 of 3) display 6-192
- AMDPDM3–Control File Maintenance (Page 3 of 3) display 6-193
- AME4601–Roll Current to Standard Costs display 5-37
- AME751–WIP Cost Worksheet (Select) display 4-26
- AME78–Calculate Cumulative Yield report 7-2, 8-87
- AME82–Calculate Adjusted Quantity Per report 7-3, 8-90
- AME86–Work-in-Process Cost Worksheet–Current, Standard, or Average Costs 4-25, 8-82
- AMEB0–Product Structure Offline Maintenance Edit List 10-4, A-3
- AMEB3–Routing Offline Maintenance Edit List A-3
- AMEC40–Single Level Costed (Select) display 3-23
- AMEC41–Single Level Costed–Current (Inquiry) display 3-25
- AMEC42–Single Level Costed–Standard (Inquiry) display 3-29
- AMEC70–Product Structure Retrievals (Select) display 3-4, 3-8
- AMEC71–Single Level Bill of Material (Inquiry) display 3-5, 3-10
- AMEC72–Indented Bill of Material (Inquiry) display 3-13
- AMEC73–Single Level Where-Used (Inquiry) display 3-16
- AMEC74–Single Level Bill With Blow-Through (Inquiry) display 3-19

AMED40–Routing Operations (Select) display 3-31
 AMED41–Routing Operations (Inquiry) display 3-32
 AMED46–Routing Operation Description (Inquiry) display, 3-37
 AMED80–Feature/Options (Select) display 3-48
 AMED81–Feature/Options (Inquiry) display, 3-49
 AMEF1–Feature/Options Report 8-27
 AMEF1–Feature/Options report 4-8
 AMEF41–Retrieval Selections–Regular–Single List (Select) display 4-10
 AMEF42–Retrieval Selections–Regular–Multi-list (Select) display 4-12
 AMEF43–Costed Reports–Costed–Single List (Select) display 4-21
 AMEF44–Costed Reports–Costed–Multi List (Select) display 4-23
 AMEF45–Retrieval Selections–Regular–Single List (Select) display 4-14
 AMEF46–Retrieval Selections–Regular–Single List (Select) display 4-16
 AMEF47–Retrieval Selections–Regular–Single List (Select) display 4-18
 AMEF71–Single Level Bill with Blow-Through report 4-9, 8-35
 AMEF72–Indented Bill 4-9, 8-30
 AMEF73–Summarized Bill 4-9, 8-38
 AMEF74–Single Level Where-Used report 4-9, 8-37
 AMEF75–End-Item Where-Used report 4-9, 8-25
 AMEG11–Routing List 4-9, 8-57
 AMEG12–Production Facility Where-Used report 4-9, 8-48
 AMEG4–Routing and Single Level Retrieval with Blow-Through report 4-9, 8-52
 AMEG71–Single Level Cost Sheet—Curr or Std, Single or Multi-Item, with or w/out Blow-thr 4-20, 8-78
 AMEG72–Indented Cost Sheet–Current or Standard 4-20, 8-64
 AMEH41–Routing Operation and Single Level Cost Sheet–Current 4-20, 8-69
 AMEH42–Routing Operation and Single Level Cost Sheet–Standard 4-20, 8-69
 AMEH7–Management Cost Summary–Current or Standard report 4-20, 8-67
 AMEH8–Cost Variations–Current to Standard report 4-20, 8-61
 AMEI30–Product Cost Update Report–Current or Standard Costs 5-4, 8-73
 AMEI31–Product Cost Simulation—Curr and Std Costs or Aver Costs After Chg By Percent 8-75
 AMEI31–Product Cost Simulation–Current or Standard report 5-7
 AMEJ70–Product Cost Simulation (Select) display 5-8
 AMEJ71–Product Cost Simulation–Change by Item (Select) display 5-10
 AMEJ72–Product Cost Simulation–Change by Item (Enter) display 5-11
 AMEJ73–Product Cost Simulation–Change by Item (Review) display 5-13
 AMEJ74–Product Cost Simulation–Change by Facility (Select) display 5-15
 AMEJ75–Product Cost Simulation–Change by Facility (Enter) 5-16
 AMEJ76–Product Cost Simulation–Change by Facility (Review) display 5-18
 AMEJ77–Product Cost Simulation–Change by Percent (Enter) display 5-20
 AMEJ78–Product Costing (Select) display 5-5
 AMEM06, option 1 7-2
 AMEM06, option 2 7-3
 AMEP55–Item Master Offline Maintenance Options display 6-182
 AMEPT8–Item Foreign Language Descriptions display 4-29
 AMET50–Item Cost Percent Change (Chang%) display 5-24
 AMET5–Item Cost Percent Change Audit report 5-23
 AMEU11–Product Structure File Maintenance (Select) display 6-32
 AMEU12–Product Structure File Maintenance (Add/Review) display 6-35
 AMEU13–Product Structure File Maintenance (Change/Review) display 6-40
 AMEU14–Product Structure File Maintenance (Mass Replace/Review) display 6-42
 AMEU15–Product Structure File Maintenance (Delete/Review) display 6-44
 AMEU16–Product Structure File Maintenance (Mass Delete/Review) display 6-46
 AMEU17–Product Structure File Maintenance (Structure Delete/Review) display 6-49
 AMEU18–Product Structure File Maintenance (Batch Status) display 6-51
 AMEU21–Routing File Maintenance (SAE Header) display 6-125
 AMEU22–Routing File Maintenance (SAE Change) display 6-129
 AMEU23–Routing File Maintenance (SAE Delete) display 6-131
 AMEU24–Routing File Maintenance (SAE Add) display 6-133
 AMEU26–Routing File Maintenance (Batch Status) display 6-135
 AMEU27–Routing File Maintenance (SAE Addl Desc Maint) display 6-137
 AMEU28–Routing File Maintenance (SAE MS–MNT) display 6-140

AMEU31–Product Structure File Maintenance (SAE Header) display 6-53
 AMEU32–Product Structure File Maintenance (SAE Change) display 6-56
 AMEU33–Product Structure File Maintenance (SAE Delete) display 6-58
 AMEU34–Product Structure File Maintenance (SAE Add) display 6-60
 AMEU35–Product Structure File Maintenance (Batch Status) display 6-62
 AMEU41–Product Structure File Maintenance (Review) display 6-64
 AMEU42–Product Structure File Maintenance (Review) display 6-66
 AMEU43–Product Structure File Maintenance, Batch Status display 6-69
 AMEU5–Product Structure Transaction List 6-28, 8-32
 AMEU61–Routing File Maintenance–Data Entry Control display 6-101
 AMEU71–Routing File Maintenance (Select) display 6-104
 AMEU72–Routing File Maintenance (Add/Review) display 6-106
 AMEU73–Routing File Maintenance (Change/Review) display 6-112
 AMEU75–Routing File Maintenance (Delete) display 6-114
 AMEU76–Routing File Maintenance (Routing Delete) display 6-116
 AMEU77–Routing File Maintenance (Batch Status) display 6-118
 AMEU78–Routing File Maintenance (Update) display 6-121
 AMEU79–Routing File Maintenance (MS-MAINT) display 6-123
 AMEU81–Routing File Maintenance (Review) display 6-142
 AMEU82–Routing File Maintenance (Review) display 6-144
 AMEU83–Routing File Maintenance (Batch Status) display 6-148
 AMEU84–Routing File Maintenance (Review) display 6-150
 AMEU85–Routing File Maintenance (Review) display 6-152
 AMEU9–Routing Transaction List 6-100, 8-59
 AMEUA1–Product Structure Data Entry Control display 2-1
 AMEUA1–Product Structure File Maintenance–Data Entry Control display 6-29
 AMEUG1–Product Structure File Maintenance (Review) display 6-71
 AMEUK1–Routing File Maintenance (Review) 6-154
 AMKE1–Item Master Offline Maintenance Edit List 6-181, A-3
 AMKE3–Item Master Offline Load Audit List 6-181
 AMMM00–MRP Main Menu 1-4
 AMV43–Production Facility Report , sample 8-44
 AMV43–Production Facility Report–Sequenced by Facility or Department 4-6, 4-7
 AMVADPFR–sample code file report 6-174
 AMVD1PFR–Items with Foreign Language Descriptions report 4-28
 AMVD60–Production Facility (Select) display 3-40
 AMVD61–Production Facility Inquiry display 3-41
 AMVD62–Production Facility Inquiry–Variable Capacity display 3-45
 AMVD90–Feature/Options with S-Number Build (Select) display 3-52
 AMVD91–Feature/Options with S-Number Build (Inquiry) display, 3-53
 AMVDYPFR–Items without Foreign Language Descriptions report 4-28
 AMVE11–Item Master Report (Select) display 4-4
 AMVE40–Item Master File Report–Brief 4-3
 AMVE40–Item Master File Report–Brief 8-15
 AMVE41–Item Master File Report–Complete 4-3
 AMVE41–Item Master File Report–Complete 8-18
 AMVE42–Item Master File Report–Current or Standard Costs 4-3
 AMVE42–Item Master File Report–Current or Standard Costs 8-20
 AMVE43–Item Master File Report–Purchase Item Detail 4-3
 AMVE43–Item Master File Report–Purchase Item Detail 8-22
 AMVE44–Item Master File Report–Purchase Item Description 4-3
 AMVE44–Item Master File Report–Purchase Item Description 8-24
 AMVPOF–Product Structure Offline Maintenance Options display 6-185
 AMVPOF–Production Facility Offline Maintenance Options 6-187
 AMVPOF–Production Facility Offline Maintenance Options display 6-187
 AMVPOF–Routing Offline Maintenance Options 6-189
 AMVT01–Item Master File Maintenance (Select) display 6-6
 AMVT02–Item Master File–General Information (Add/Change/Delete/Set Defaults)
 display 6-9
 AMVT03–Item Master File–Additional Information (Add/Change/Delete/Set
 Defaults) display 6-15
 AMVT04–Item Master File–Costing Information (Add/Change/Delete/Set Defaults)
 display 6-18
 AMVT06–Item Master File Maintenance (Status) display 6-27

AMVT0–Item Master File Maintenance report 6-4, 8-3
 AMVT70–Production Facility Maintenance (Select) display 6-74
 AMVT71–Production Facility Maintenance (Add) display 6-76
 AMVT72–Production Facility Maintenance (Change) display 6-81
 AMVT73–Production Facility Maintenance, (Delete) display 6-82
 AMVT74–Production Facility Maintenance (Change %) display 6-83
 AMVT7–Production Facility Maintenance report 6-73, 8-39
 AMVTC1–Variable Capacity Maintenance (Select) display 6-87
 AMVTC2–Variable Capacity Maintenance (Add) display 6-89
 AMVTC3–Variable Capacity Maintenance (Change) display 6-92
 AMVTC4–Variable Capacity Maintenance (Delete) display 6-94
 AMVTC5–Variable Capacity Maintenance (Delete All) display 6-96
 AMVTC6–Variable Capacity Maintenance (Status) display 6-98
 AMVTC–Variable Capacity File Maintenance report 8-51
 AMVTC–Variable Capacity Master File Maintenance report 6-73
 AMVTE–Production Facility Offline Maintenance Edit List A-3
 AMVX71–Labor/Overhead Table (Change) display 5-27, 5-30
 AMVX72–Purchase Overhead Table (Change) display 5-32, 5-35
 application interfaces 1-1
 audit
 trail
 Production Facility file maintenance 6-85
 audit trail
 file maintenance 6-3
 Item Master edit/load 10-1
 Item Master file maintenance 10-9
 Product Structure edit/load 10-4
 Product Structure file maintenance 10-10
 Product Structure file reorganization 10-17
 Production Facility file maintenance 10-12
 Routing Description file reorganization 10-19
 Routing edit/load 10-5
 Routing file maintenance 10-14
 Routing file reorganization 10-18
 Variable Capacity file maintenance 10-13
 automated job submission 1-9, D-1

B

batch
 conflicts 6-3
 Data Entry Control display, selecting a batch 2-1
 description of 2-1
 immediate update 2-1
 reports printed after Product Structure update 10-10
 reports printed after Routing update 10-14
 selecting or starting a batch 2-1
 status
 active 2-1
 closed 2-1
 delete 2-1
 finish 2-1
 suspend (SUSPND) 2-1
 update 2-1
 status displays
 Product Structure File Maintenance (Batch Status)–AMEU18 6-51
 Product Structure File Maintenance (Batch Status)–AMEU35 6-62
 Product Structure File Maintenance, Batch Status–AMEU43 6-69
 Routing File Maintenance (Batch Status)–AMEU26 6-135
 Routing File Maintenance (Batch Status)–AMEU77 6-118
 Routing File Maintenance (Batch Status)–AMEU83 6-148
 update

- product structure file 6-29
- Product Structure file maintenance 6-3
- Routing Description file maintenance 6-3
- Routing file maintenance 6-3, 6-101
- update methods 2-1
- batch status 2-1
- batches
 - immediate update 2-1
 - selecting or starting a batch 2-1
 - status
 - active 2-1
 - closed 2-1
 - delete 2-1
 - finish 2-1
 - suspend (SUSPND) 2-1
 - update 2-1
- bill of material
 - building 9-19
 - description of 2-6, 2-11
 - end-item where-used implosion C-2
 - in component item order, example 9-19
 - in user sequence order, example 9-19
 - indented explosion C-1, C-3
 - indented implosion C-3
 - level tables C-3
 - low-level codes C-3
 - phantoms C-14
 - reports
 - End-Item Where-Used-AMEF75 4-9
 - Indented Bill-AMEF72 4-9, 8-30
 - Indented Cost Sheet-Current or Standard-AMEG72 4-20
 - Routing and Single Level Retrieval with Blow-Through-AMEG4 4-9
 - Routing Operation and Single Level Cost Sheet-Current-AMEH41 4-20
 - Routing Operation and Single Level Cost Sheet-Standard-AMEH42 4-20
 - Single Level Bill with Blow-Through-AMEF71 4-9, 8-35
 - Single Level Cost Sheet-Curr or Std, Single or Multi-Item, with or w/out Blow-thr-AMEG71 4-20
 - Single Level Where-Used-AMEF74 4-9, 8-37
 - Summarized Bill-AMEF73 4-9, 8-38
 - single level explosion C-1
 - single level explosion with blow-through C-1
 - single level implosion C-2
 - structured in component item order, example 9-20
 - structured in user sequence order, example 9-20
 - summarized explosion C-1

C

- Calculate Adjusted Quantity Per report-AME82 7-3, 8-90
- Calculate Cumulative Yield report-AME78 7-2, 8-87
- calculating
 - adjusted quantity per 2-29, 7-3
 - adjusted run hours 2-30
 - cost technique code R 2-20
 - cost technique code T 2-20
 - cumulative yield 7-2
 - cumulative yield through previous operation 2-28
 - Item Foreign Language file 2-10
 - Item Master file 2-5
 - operation yield 2-28
 - product costing 2-16
 - Product Structure file 2-6

- Production Facility file 2-7
- Routing Description file 2-9
- Routing file 2-8
- total cumulative yield 2-28
- yields 7-1
- calculations, description C-1
- calculations, mfg overhead C-10
- calculations, outside operations C-11
- Capacity Requirements Planning 2-5
- changing
 - additional routing descriptions 6-121
 - additional routing descriptions (SAE) 6-137
 - by costing date (simulation) 5-9
 - component items in product structures 6-40
 - component items in product structures (mass replacing) 6-42
 - Labor/Overhead Costing Table 5-27, 5-30
 - percent change of facility cost rates (simulation) 5-20
 - percent change of material, by item class 5-24
 - percent change of production facility cost rates 6-83
 - percent change of purchase content, by item class (simulation) 5-20
 - Purchase Overhead Costing Table 5-32, 5-35
 - records in offline files A-4
 - routing operation 6-112
 - routing operation (SAE) 6-129
 - SAE component items 6-56
 - user sequence number 6-33
 - using average yield (simulation) 5-9
 - variable capacity record 6-92
- CIM Series/400 and Infor ERP XA 6-3
- closed batch 2-1
- code file maintenance
 - code file report 6-174
 - definition 6-167
 - how to add codes 6-177
 - how to change code information 6-176
 - how to delete codes 6-178
 - how to end code file maintenance 6-179
 - how to see a list of codes 6-175
 - panels 6-171
 - scrolling the code list 6-168
- codes, low-level C-3, C-4
- component item
 - adding 6-35
 - adding SAE 6-60
 - changing 6-40
 - changing SAE 6-56
 - deleting 6-44
 - deleting SAE 6-58
 - mass deleting 6-46
 - mass replacing 6-42
 - user sequence change 6-33
- conflicts, batch 6-3
- conflicts, file maintenance 6-3
- continuity checking, product structure C-4
- cost
 - calculations 2-20
 - code blank 2-20
 - code R 2-20
 - code T 2-20
 - cost technique codes 2-20
 - current
 - description 5-1
 - simulation 5-3
 - description of 2-17, 2-20

- feature items 2-18, 2-19, 2-21
- features C-14
- for purchased, manufactured, and special (item type 9) items, figure of 2-18
- formula for CTECH=R C-7
- formulas C-6
- Item Master file maintenance 2-18
- lower-level content 2-17
- low-level codes C-3
- manufactured items 2-18
- phantoms C-14
- Product Structure file maintenance 2-17
- purchased items 2-18
- recost flag 2-25
- roll-up, description C-12
- Routing file maintenance 2-17
- special items 2-18
- technique codes
 - code R 5-1
 - code T 5-1
- this-level content 2-17
- cost formulas used for CTECH=R C-7
- cost roll-up, description of 2-22
- cost status code 2-25
- Cost Variations—Current to Standard report—AMEH8 4-20
- Costed Reports—Costed—Multi List (Select) display—AMEF44 4-23
- Costed Reports—Costed—Single List (Select) display—AMEF43 4-21
- costing
 - cost technique blank 2-20
 - cost technique R 2-20
 - cost technique T 2-20
 - displays
 - Costed Reports—Costed—Multi List (Select)—AMEF44 4-23
 - Costed Reports—Costed—Single List (Select)—AMEF43 4-21
 - Item Cost Percent Change (Chang%)—AMET50 5-24
 - Labor/Overhead Table (Change)—AMVX71 5-27, 5-30
 - Product Cost Simulation (Select)—AMEJ70 5-8
 - Product Cost Simulation—Change by Facility (Enter)—AMEJ75 5-16
 - Product Cost Simulation—Change by Facility (Review)—AMEJ76 5-18
 - Product Cost Simulation—Change by Facility (Select)—AMEJ74 5-15
 - Product Cost Simulation—Change by Item (Enter)—AMEJ72 5-11
 - Product Cost Simulation—Change by Item (Review)—AMEJ73 5-13
 - Product Cost Simulation—Change by Item (Select)—AMEJ71 5-10
 - Product Cost Simulation—Change by Percent (Enter)—AMEJ77 5-20
 - Product Costing (Select)—AMEJ78 5-5
 - Purchase Overhead Table (Change)—AMVX72 5-32
 - WIP Cost Worksheet (Select)—AME751 4-26
 - displays, Production Facility Maintenance (Change %)—AMVT74 6-83
 - Management Cost Summary—Current or Standard—AMEH7 4-20
 - options 5-2
 - process
 - percent changes 10-20
 - percent changes (audit trail) 10-20
 - report printed after percent changes 10-20
 - Purchase Overhead Table (Change)—AMVX72 5-35
- reports
 - Cost Variations—Current to Standard—AMEH8 4-20, 8-61
 - descriptions 1-9
 - Indented Cost Sheet—Current or Standard—AMEG72 4-20, 8-64
 - Item Cost Percent Change Audit report—AMET5 5-23
 - Management Cost Summary—Current or Standard—AMEH7 8-67
 - options 4-2
 - Product Cost Simulation—Current or Standard—AMEI31 5-7
 - Product Cost Update Report—Current or Standard Costs—AMEI30 5-4
 - Retrieval Selections—Costed 4-20

Routing Operation and Single Level Cost Sheet–Current–AMEH41 4-20, 8-69
 Routing Operation and Single Level Cost Sheet–Standard–AMEH42 4-20, 8-69
 Single Level Cost Sheet—Curr or Std, Single or Multi-Item, with or w/out Blow-thr–AMEG71 8-78
 Work-in-Process Cost Worksheet–Current, Standard, or Average Costs–AME86 4-25, 8-82
 Roll Current to Standard Costs–AME4601 5-37
 Costing Work file (partial Item Master file) (COSTWK) 1-7
 creating offline files A-1
 cumulative yields, calculating 7-2
 current unit cost 2-17
 Customer Order Management 2-5

D

data entry
 batch 2-1
 control displays
 Product Structure File Maintenance–Data Entry Control–AMEUA1 6-29
 Routing File Maintenance–Data Entry Control–AMEU61 6-101
 example of 2-1
 file maintenance using maintenance data entry forms, figure of 6-3
 forms
 Item Master File Maintenance–Additional Information–PM-02 6-4
 Item Master File Maintenance–Costing Information–PM-03 6-4
 Item Master File Maintenance–General Information–PM-01 6-4
 Item Master File Maintenance–Purchasing Information–PM-04 6-4
 Item Master Offline Maintenance (A-Record)–PM-26A 6-181
 Item Master Offline Maintenance (A-Record)–PM-26B 6-181
 Item Master Offline Maintenance (B-Record)–PM-27 6-181
 Item Master Offline Maintenance (C-Record)–PM-28 6-181
 Product Structure File Maintenance–PM-14 6-28, 9-16
 Production Facility File Maintenance–PM-23 6-73
 Purchase Overhead Table–Change Entry–PM-16 9-29
 Routing Description File Maintenance–Additional Operation Descriptions–PM-21 9-35
 Routing File Maintenance–PM-17 6-100, 9-31
 Routing File Milestone Group Maintenance–PM-18 6-100, 9-33
 using 9-1
 Variable Capacity Master File Maintenance–TM-01 6-73
 forms ,Variable Capacity Master File Maintenance–TM-01 9-44
 offline files A-2
 offline files, description A-1
 online 2-1
 selecting or starting a batch 2-1
 status
 active 2-1
 closed 2-1
 delete 2-1
 finish 2-1
 suspend (SUSPND) 2-1
 update 2-1
 delete routing 2-12
 delete structure 2-12
 deleted batch 2-1
 deleting
 additional routing descriptions 6-121
 additional routing descriptions (SAE) 6-137
 all variable capacity records 6-96
 component items from product structures 6-44

- component items from product structures, mass 6-46
- entire routings 6-116
- milestone groups 6-123
- milestone groups (SAE) 6-140
- product structures 6-49
- production facility records 6-82
- records in offline files A-4
- routing operations 6-114
- routing operations (SAE) 6-131
- routing transactions 6-142
- SAE component items 6-58
- variable capacity records 6-94
- diskettes, loading
 - loading files, summary 2-10
 - loading Item Foreign Language file 2-10
 - loading Item Master file 2-6
 - loading Product Structure file 2-6
 - loading Routing file 2-8
 - offline data entry forms for Product Structure file 2-6
- displays
 - Costed Reports—Costed—Multi List (Select)—AMEF44 4-23
 - Costed Reports—Costed—Single List (Select)—AMEF43 4-21
 - Feature Options (Select)—AMED80 3-48
 - Feature Options with S-Number Build (Select)—AMVD90 3-52
 - Feature/Options (Inquiry)—AMED81 3-49
 - Feature/Options with S-Number Build (Inquiry)—AMVD91 3-53
 - general information 1-4
 - Indented Bill of Material (Inquiry)—AMEC72 3-13
 - Item Cost Percent Change (Chang%)—AMET50 5-24
 - Item Foreign Language Descriptions—AMEPT8 4-29
 - Item Master File
 - Additional Information,(Add/Change/Delete/Set Defaults)—AMVT03 6-15
 - Costing Information,(Add/Change/Delete/Set Defaults)—AMVT04 6-18
 - General Information (Add/Change/Delete/Set Defaults)—AMVT02 6-9
 - Maintenance (Select)—AMVT01 6-6
 - Maintenance (Status)—AMVT06 6-27
 - Purchasing Information (Add/Change/Delete/Set Defaults)—AMVT05 6-23
 - Item Master Offline Maintenance Options—AMVPOF 6-182
 - Item Master Report (Select)—AMVE11 4-4
 - Labor/Overhead Table (Change)—AMEX71 5-27
 - Labor/Overhead Table (Change)—AMVX71 5-30
 - MRP Main Menu—AMMM00 1-4
 - Product Cost Simulation (Select)—AMEJ70 5-8
 - Product Cost Simulation—Change by Facility (Enter)—AMEJ75 5-16
 - Product Cost Simulation—Change by Facility (Review)—AMEJ76 5-18
 - Product Cost Simulation—Change by Facility (Select)—AMEH74 5-15
 - Product Cost Simulation—Change by Item (Enter)—AMEJ72 5-11
 - Product Cost Simulation—Change by Item (Review)—AMEJ73 5-13
 - Product Cost Simulation—Change by Item (Select)—AMEJ71 5-10
 - Product Cost Simulation—Change by Percent (Enter)—AMEJ77 5-20
 - Product Costing (Select)—AMEJ78 5-5
 - Product Structure File Maintenance (Add/Review)—AMEU12 6-35
 - Product Structure File Maintenance (Batch Status)—AMEU18 6-51
 - Product Structure File Maintenance (Batch Status)—AMEU35 6-62
 - Product Structure File Maintenance (Change/Review)—AMEU13 6-40
 - Product Structure File Maintenance (Delete/Review)—AMEU15 6-44
 - Product Structure File Maintenance (Mass Delete/Review)—AMEU16 6-46
 - Product Structure File Maintenance (Mass Replace/Review)—AMEU14 6-42
 - Product Structure File Maintenance (Review)—AMEU41 6-64
 - Product Structure File Maintenance (Review)—AMEU42 6-66
 - Product Structure File Maintenance (Review)—AMEUG1 6-71
 - Product Structure File Maintenance (SAE Add)—AMEU34 6-60
 - Product Structure File Maintenance (SAE Change)—AMEU32 6-56
 - Product Structure File Maintenance (SAE Delete)—AMEU33 6-58

Product Structure File Maintenance (SAE Header)–AMEU31 6-53
 Product Structure File Maintenance (Select)–AMEU11 6-32
 Product Structure File Maintenance (Structure Delete/Review)–AMEU17 6-49
 Product Structure File Maintenance, Batch Status–AMEU43 6-69
 Product Structure File Maintenance–Data Entry Control–AMEUA1 6-29
 Product Structure Offline Maintenance Options–AMEP57 6-185
 Product Structure Offline Maintenance Options–AMVPOF 6-185
 Product Structure Retrievals (Select)–AMEC70 3-4, 3-8
 Production Facility
 (Select)–AMVD60 3-40
 Inquiry–AMVD61 3-41
 Production Facility Maintenance
 (Add)–AMVT71 6-76
 (Change %)-AMVT74 6-83
 (Change)–AMVT72 6-81
 (Delete)–AMVT73 6-82
 (Select)–AMVT70 6-74
 Production Facility Offline Maintenance Options–AMEP5L 6-187
 Production Facility Offline Maintenance Options–AMVPOF 6-187
 Purchase Overhead Table (Change)–AMVX72 5-32, 5-35
 Retrieval Selections–Regular–Multi-list (Select)–AMEF42 4-12
 Retrieval Selections–Regular–Single List (Select) display–AMEF41 4-10
 Retrieval Selections–Regular–Single List (Select) display–AMEF45 4-14
 Retrieval Selections–Regular–Single List (Select) display–AMEF46 4-16
 Retrieval Selections–Regular–Single List (Select) display–AMEF47 4-18
 Roll Current to Standard Costs –AME4601 5-37
 Routing File Maintenance (Add/Review)–AMEU72 6-106
 Routing File Maintenance (Batch Status)–AMEU26 6-135
 Routing File Maintenance (Batch Status)–AMEU77 6-118
 Routing File Maintenance (Batch Status)–AMEU83 6-148
 Routing File Maintenance (Change/Review)–AMEU73 6-112
 Routing File Maintenance (Delete)–AMEU75 6-114
 Routing File Maintenance (MS-MAINT)–AMEU79 6-123
 Routing File Maintenance (Review)–AMEU81 6-142
 Routing File Maintenance (Review)–AMEU82 6-144
 Routing File Maintenance (Review)–AMEU84 6-150
 Routing File Maintenance (Review)–AMEU85 6-152
 Routing File Maintenance (Review)–AMEUK1 6-154
 Routing File Maintenance (Routing Delete)–AMEU76 6-116
 Routing File Maintenance (SAE Add)–AMEU24 6-133
 Routing File Maintenance (SAE Addl Desc Maint)–AMEU27 6-137
 Routing File Maintenance (SAE Delete)–AMEU23 6-131
 Routing File Maintenance (SAE Header)–AMEU21 6-125
 Routing File Maintenance (SAE MS–MNT)–AMEU28 6-140
 Routing File Maintenance (Select)–AMEU71 6-104
 Routing File Maintenance (Update)–AMEU78 6-121
 Routing File Maintenance, SAE Change–AMEU22 6-129
 Routing File Maintenance–Data Entry Control–AMEU61 6-101
 Routing Offline Maintenance Options–AMVPOF 6-189
 Routing Operation Description (Inquiry)–AMED46 3-37
 Routing Operations (Inquiry)–AMED41 3-32
 Routing Operations (Select)–AMED40 3-31
 Single Level Bill of Material (Inquiry)–AMEC71 3-5, 3-10
 Single Level Bill With Blow-Through (Inquiry)–AMEC74 3-19
 Single Level Costed (Select)–AMEC40 3-23
 Single Level Costed–Current (Inquiry)–AMEC41 3-25
 Single Level Costed–Standard (Inquiry)–AMEC42 3-29
 Single Level Where-Used (Inquiry)–AMEC73 3-16
 Variable Capacity Maintenance
 (Add) display–AMVTC2 6-89
 (Change) display–AMVTC3 6-92
 (Delete All) display–AMVTC5 6-96
 (Delete) display–AMVTC4 6-94
 (Select) display–AMVTC1 6-87

(Status) display--AMVTC6 6-98
 WIP Cost Worksheet (Select)--AME751 4-26

E

edit/load
 Item Master 10-1
 Product Structure 10-4
 Routing 10-5
 effective dates 2-6
 effectivity dates, file maintenance 6-38, 6-43, 6-67
 effectivity dates, inquiry 3-12, 3-15, 3-17, 3-21, 3-24, 3-26
 end-item where-used implosion routine C-2
 End-Item Where-Used report--AMEF75 4-9, 8-25
 engineering changes 2-6
 entering data into offline files A-2
 establishing controls 2-2
 Euro currency 5-1

F

Feature Options (Select) display--AMED80 3-48
 Feature/Options (Inquiry) display--AMED81 3-49
 Feature/Options with S-Number Build (Inquiry) display--AMVD91 3-53
 Feature/Options with S-Number Build (Select) display--AMVD90 3-52
 features and options
 application tailoring C-13
 as components C-14
 bill of material with features and options, figure of 2-13
 costing C-14
 description C-13
 description of 2-13, 2-18, 2-19, 2-21
 eliminate 2-15
 end-items C-13
 example using an S-number 2-14
 Feature/Options Report--AMEF1 8-27
 Feature/Options report--AMEF1 4-8
 handling C-13
 report options 4-1
 stocking C-14
 template, description C-13
 versus phantoms, description C-14
 file maintenance
 code files 6-167
 conflicts 6-3
 cost elements 2-17
 description 6-3
 description of 2-11
 displays
 Item Master Offline Maintenance Options--AMEP55 6-182
 Product Structure File Maintenance (Add/Review)--AMEU12 6-35
 Product Structure File Maintenance (Batch Status)--AMEU18 6-51
 Product Structure File Maintenance (Batch Status)--AMEU35 6-62
 Product Structure File Maintenance (Change/Review)--AMEU13 6-40
 Product Structure File Maintenance (Delete/Review)--AMEU15 6-44
 Product Structure File Maintenance (Mass Delete/Review)--AMEU16 6-46
 Product Structure File Maintenance (Mass Replace/Review)--AMEU14 6-42
 Product Structure File Maintenance (Review)--AMEU41 6-64
 Product Structure File Maintenance (Review)--AMEU42 6-66
 Product Structure File Maintenance (Review)--AMEUG1 6-71
 Product Structure File Maintenance (SAE Add)--AMEU34 6-60

Product Structure File Maintenance (SAE Change)—AMEU32 6-56
 Product Structure File Maintenance (SAE Delete)—AMEU33 6-58
 Product Structure File Maintenance (SAE Header)—AMEU31 6-53
 Product Structure File Maintenance (Select)—AMEU11 6-32
 Product Structure File Maintenance (Structure Delete/Review)—AMEU17 6-49
 Product Structure File Maintenance—Data Entry Control—AMEUA1 6-29
 Product Structure Offline Maintenance Options—AMEP57 6-185
 Production Facility Maintenance (Add)—AMVT71 6-76
 Production Facility Maintenance (Change %)—AMVT74 6-83
 Production Facility Maintenance (Change)—AMVT72 6-81
 Production Facility Maintenance (Select)—AMVT70 6-74
 Production Facility Maintenance, (Delete)—AMVT73 6-82
 Production Facility Offline Maintenance Options—AMEP5L 6-187
 Routing File Maintenance (Add/Review)—AMEU72 6-106
 Routing File Maintenance (Batch Status)—AMEU26 6-135
 Routing File Maintenance (Batch Status)—AMEU77 6-118
 Routing File Maintenance (Batch Status)—AMEU83 6-148
 Routing File Maintenance (Change/Review)—AMEU73 6-112
 Routing File Maintenance (Delete)—AMEU75 6-114
 Routing File Maintenance (MS-MAINT)—AMEU79 6-123
 Routing File Maintenance (Review)—AMEU81 6-142
 Routing File Maintenance (Review)—AMEU82 6-144
 Routing File Maintenance (Review)—AMEU84 6-150
 Routing File Maintenance (Review)—AMEU85 6-152
 Routing File Maintenance (Review)—AMEUK1 6-154
 Routing File Maintenance (Routing Delete)—AMEU76 6-116
 Routing File Maintenance (SAE Add)—AMEU24 6-133
 Routing File Maintenance (SAE Addl Desc Maint)—AMEU27 6-137
 Routing File Maintenance (SAE Delete)—AMEU23 6-131
 Routing File Maintenance (SAE Header)—AMEU21 6-125
 Routing File Maintenance (SAE MS—MNT)—AMEU28 6-140
 Routing File Maintenance (Select)—AMEU71 6-104
 Routing File Maintenance (Update)—AMEU78 6-121
 Routing File Maintenance, SAE Change—AMEU22 6-129
 Routing File Maintenance—Data Entry Control—AMEU61 6-101
 Variable Capacity Maintenance (Add) display—AMVTC2 6-89
 Variable Capacity Maintenance (Change) display—AMVTC3 6-92
 Variable Capacity Maintenance (Delete All) display—AMVTC5 6-96
 Variable Capacity Maintenance (Delete) display—AMVTC4 6-94
 Variable Capacity Maintenance (Select) display—AMVTC1 6-87
 Variable Capacity Maintenance (Status) display—AMVTC6 6-98
 Item Base Price 6-1, 6-157
 Item Foreign Language Descriptions 6-162
 Item Master 6-1
 Item Master File
 Additional Information, Add/Change/Delete/Set Defaults—AMVT03 6-15
 Costing Information, Add/Change/Delete/Set Defaults—AMVT04 6-18
 General Information (Add/Change/Delete/Set Defaults)—AMVT02 6-9
 Maintenance (Select)—AMVT01 6-6
 Maintenance (Status)—AMVT06 6-27
 Purchasing Information
 (Add/Change/Delete/Set Defaults)—AMVT05 6-23
 offline
 description A-1
 entering changes and deletions A-4
 Item Master 6-181
 Product Structure 6-184
 Product Structure Offline Maintenance form—PM-15 9-18
 Production Facility 6-186
 Production Facility Offline Maintenance form—PM-30A 9-41
 Production Facility Offline Maintenance form—PM-30B 9-42
 Routing 6-188
 Routing File Offline Maintenance form—PM-29 9-37

- using forms 9-1
- Product Structure 6-1
- reports
 - Item Master File Maintenance–AMVT0 6-4
 - Item Master Offline Load Audit List–AMKE3 6-181
 - Item Master Offline Maintenance Edit List–AMKE1 6-181, A-3
 - Product Structure Offline Maintenance Edit List–AMEB0 10-4, A-3
 - Product Structure Transaction List–AMEU5 6-28, 8-32
 - Production Facility Maintenance–AMVT7 6-73
 - Production Facility Offline Maintenance Edit List–AMVTE A-3
 - Routing Offline Maintenance Edit List–AMEB3 A-3
 - Routing Transaction List–AMEU9 6-100, 8-59
 - Variable Capacity Master File Maintenance–AMVTC 6-73
- Routing 6-1
- security 1-7
- special maintenance transactions 2-12
- using maintenance data entry forms 6-3
- File Maintenance displays
 - Control File Maintenance (Page 1 of 3)–AMDPDM1 6-191
 - Control File Maintenance (Page 2 of 3)–AMDPDM2 6-192
 - Control File Maintenance (Page 3 of 3)–AMDPDM3 6-193
- file relationships
 - Item Master and Product Structure files, figure of 2-7
 - Product Data Management files, figure of 2-10
- file summary 2-10
- files
 - code file maintenance 6-167
 - creating master 2-3
 - creating transactions 2-4
 - format, offline
 - description A-1
 - general information 1-5
 - Item Foreign Language Description
 - description 1-5
 - Item Foreign Language file 2-10
 - Item Master 2-5
 - description 1-6
 - master 2-5
 - offline
 - creating A-1
 - description A-1
 - entering changes and deletions A-4
 - entering data A-2
 - Item Master Offline Maintenance Edit List–AMKE1 A-3
 - loading A-2
 - loading to PDM A-3
 - names A-2
 - options 6-1
 - processing A-4
 - Product Structure (PSDSKT) A-11
 - Product Structure Offline Maintenance Edit List–AMEB0 10-4, A-3
 - Product Structure Offline Maintenance form–PM-15 9-18
 - Production Facility (PFDSKT) A-12
 - Production Facility Offline Maintenance Edit List–AMVTE A-3
 - Production Facility Offline Maintenance form–PM-30A 9-41
 - Production Facility Offline Maintenance form–PM-30B 9-42
 - Routing (RTGDKT) A-8
 - Routing File Offline Maintenance form–PM-29 9-37
 - Routing Offline Maintenance Edit List–AMEB3 A-3
 - special data requirements A-3
 - using forms 9-1
- permanent 1-5
- Product Structure 2-6
 - description 1-6

- reorganization 10-17
- Production Facility 2-7
 - description 1-6
- relationships, summary 2-10
- Routing 2-8
 - description 1-6
 - reorganization 10-18
- Routing Description 2-9
 - description 1-6
 - reorganization 10-19
- sharing 1-5
- System Control, description 1-5
- temporary 1-7
- transaction 1-5
- types 1-5
- updating the PDM Control file 6-190
- used by PDM 1-5
- Variable Capacity, description 1-7
- work, description 1-7
- finished batch 2-1
- Forecasting 2-5
- foreign language descriptions 2-32
- format, offline files A-1
- forms
 - file maintenance data entry 6-3
 - Item Master File Maintenance—Additional Information—PM-02 6-4
 - Item Master File Maintenance—Costing Information—PM-03 6-4
 - Item Master File Maintenance—General Information—PM-01 6-4
 - Item Master File Maintenance—Purchasing Information—PM-04 6-4
 - Item Master Offline Maintenance (A-Record)—PM-26A 6-181
 - Item Master Offline Maintenance (A-Record)—PM-26B 6-181
 - Item Master Offline Maintenance (B-Record)—PM-27 6-181
 - Item Master Offline Maintenance (C-Record)—PM-28 6-181
 - Labor/Overhead Table—Change Entry—PM-13 5-26, 5-29, 9-15
 - list 9-1
 - Product Structure File Maintenance—PM-14 6-28, 9-16
 - Product Structure Offline Maintenance—PM-15 9-18
 - Production Facility File Maintenance—PM-23 6-73
 - Production Facility Maintenance—AMVT7 (PM-23) 9-39
 - Production Facility Offline Maintenance—PM-30A 9-41
 - Production Facility Offline Maintenance—PM-30B 9-42
 - Purchase Overhead Table—Change Entry—PM-16 5-31, 5-34, 9-29
 - Routing Description File Maintenance—Additional Operation Descriptions—PM-21 6-100, 9-35
 - Routing File Maintenance—PM-17 6-100, 9-31
 - Routing File Milestone Group Maintenance—PM-18 6-100, 9-33
 - Routing File Offline Maintenance—PM-29 9-37
 - using 9-1
 - Variable Capacity Master File Maintenance—TM-01 6-73, 9-44
- forms used, data entry
 - Item Master file maintenance—additional information (PM-02) 9-4
 - Item Master file maintenance—costing information (PM-03) 9-5
 - Item Master file maintenance—general information (PM-01) 9-3
 - Item Master file maintenance—purchasing information (PM-04) 9-6
 - Item Master offline data entry—C-record (PM-28) 9-13
 - Item Master offline file maintenance—A-record (PM-26A) 9-8, 9-11
- formulas
 - adjusted quantity per 2-29
 - adjusted run hours 2-30
 - cost technique code blank 2-20
 - cost technique code R 2-20
 - cost technique code T 2-20
- full costing
 - cost status code 2-25

- description 5-3
- description of 2-24
- recost flag 2-25
- functions
 - costing 2-16
 - features and options 2-13
 - file maintenance 2-11
 - product costing 2-16
 - S-number 2-13
 - user sequence 2-16
 - yield calculations 2-28
- functions and calculations
 - adjusted quantity per 2-29
 - adjusted run hours 2-30
 - delete routing 2-12
 - delete structure 2-12
 - description of 2-3
 - engineering changes and effective dates 2-6
 - features and options 2-13
 - file maintenance 2-11
 - file summary 2-10
 - Item Foreign Language file 2-10
 - Item Master file 2-5
 - mass delete 2-12
 - mass replace 2-12
 - negative quantities 2-24
 - operation yield 2-28
 - phantoms 2-15
 - product costing 2-16
 - Product Structure file 2-6
 - Production Facility file 2-7
 - Routing Description file 2-9
 - Routing file 2-8
 - same-as-except 2-12
 - set defaults 2-12
 - special maintenance transactions 2-12
 - standard batch quantity 2-27
 - user sequence 2-16

G

- group job
 - inquiries 3-2

H

- handling features and options C-13

I

- immediate update, description of 2-1
- Indented Bill of Material (Inquiry) display--AMEC72 3-13
- Indented Bill--AMEF72 4-9, 8-30
- Indented Cost Sheet--Current or Standard--AMEG72 4-20, 8-64
- indented explosion C-1, C-3
- indented implosion C-3
- Infor ERP XA applications, relationship to PDM
 - general information 1-1
 - interface considerations 2-4
- information flow 1-2

- inquiry
 - description 1-9
 - displays
 - Feature Options (Select)—AMED80 3-48
 - Feature Options with S-Number Build (Select)—AMVD90 3-52
 - Feature/Options (Inquiry)—AMED81 3-49
 - Feature/Options with S-Number Build (Inquiry)—AMVD91 3-53
 - Indented Bill of Material (Inquiry)—AMEC72 3-13
 - Product Structure Retrievals (Select)—AMEC70 3-4, 3-8
 - Routing Operation Description (Inquiry)—AMED46 3-37
 - Routing Operations (Inquiry)—AMED41 3-32
 - Routing Operations (Select)—AMED40 3-31
 - Single Level Bill of Material (Inquiry)—AMEC71 3-5, 3-10
 - Single Level Bill With Blow-Through (Inquiry)—AMEC74 3-19
 - Single Level Costed (Select)—AMEC40 3-23
 - Single Level Costed—Current (Inquiry)—AMEC41 3-25
 - Single Level Costed—Standard (Inquiry)—AMEC42 3-29
 - Single Level Where-Used (Inquiry)—AMEC73 3-16
 - using 3-2
 - group job inquiries 3-2
 - information security 1-7
 - prerequisites 3-2
- Inquiry displays
 - Production Facility
 - Inquiry—AMVD61 3-41
 - Inquiry displays Production Facility (Select)—AMVD60 3-40
- interface considerations 2-4
 - Capacity Requirements Planning 2-5
 - Customer Order Management 2-5
 - Forecasting 2-5
 - Inventory Management 2-4
 - Master Production Schedule Planning 2-4
 - Material Requirements Planning 2-5
 - primary 1-1
 - Production Control and Costing 2-4
 - Production Monitoring and Control 2-5
 - Purchasing 2-5
 - Repetitive Production Management 2-5
 - with other applications 1-1
- Inventory Management 2-4
- item
 - master file
 - Costing Information, Add/Change/Delete/Set Defaults display—AMVT04 6-18
 - General Information (Add/Change/Delete/Set Defaults) display—AMVT02 6-9
 - maintenance
 - (Select) display—AMVT01 6-6
 - Status display—AMVT06 6-27
 - Pricing Additional Information, Add/Change/Delete/Set Defaults display—AMVT03 6-15
 - Purchasing Information (Add/Change/Delete/Set Defaults) display—AMVT05 6-23
- Item Base Price file maintenance 6-1, 6-157
- Item Base Prices 6-157
- Item Cost Percent Change (Chang%) display—AMET50 5-24
- Item Cost Percent Change Audit report—AMET5 5-23
- Item Foreign Language Description 6-162
 - how to add foreign language item descriptions 6-165
 - how to change foreign language item descriptions 6-163
 - how to delete foreign language item descriptions 6-166
 - how to end foreign language item descriptions 6-166
 - how to see foreign language item descriptions 6-163

- how to start Item Foreign Language Description 6-162
- Item Foreign Language Description file
 - creating 2-10
 - description 1-5, 6-3
 - description of 2-10
 - maintenance 6-162
 - PDM file relationships, summary 2-10
 - prerequisites 2-10
 - report description 1-9
 - report options 4-2
 - reports
 - Items with Foreign Language Descriptions–AMVD1PFR 4-28
 - Items without Foreign Language Descriptions–AMVDYPFR 4-28
 - printed after file maintenance 6-3
- Item Foreign Language Descriptions display–AMEPT8 4-29
- Item Master file
 - audit trail 10-9
 - controls when loading 10-1
 - cost elements 2-18
 - costing simulation 5-3
 - costing updates 5-3
 - data entry forms used 2-6
 - description 1-6, 6-3
 - edit/load 10-1
 - file maintenance 6-1
 - inquiry options 3-1
 - level tables C-3
 - list 8-1
 - low-level codes C-3, C-4
 - maintenance 6-4
 - offline maintenance 6-181
 - prerequisites 2-5
 - report description 1-8
 - report printed 10-9
 - reports
 - Item Master File Maintenance–AMVT0 6-4
 - Item Master File Report–Brief–AMVE40 4-3
 - Item Master File Report–Complete–AMVE41 4-3
 - Item Master File Report–Current or Standard Costs–AMVE42 4-3
 - Item Master File Report–Purchase Item Description–AMVE44 4-3
 - Item Master File Report–Purchase Item Detail–AMVE43 4-3
 - Item Master Offline Load Audit List–AMKE3 6-181
 - Item Master Offline Maintenance Edit List–AMKE1 6-181, A-3
 - options 4-1
 - printed after file maintenance 6-3
 - set defaults 2-12
 - update method 2-1
- Item Master File Maintenance report–AMVT0 8-3
- Item Master file maintenance—additional information form (PM-02) 9-4
- Item Master File Maintenance–Additional Information form–PM-02 6-4
- Item Master file maintenance—costing information form (PM-03) 9-5
- Item Master File Maintenance–Costing Information form–PM-03 6-4
- Item Master file maintenance—general information form (PM-01) 9-3
- Item Master File Maintenance–General Information form–PM-01 6-4
- Item Master file maintenance—purchasing information form (PM-04) 9-6
- Item Master File Maintenance–Purchasing Information form–PM-04 6-4
- Item Master File Report–Brief–AMVE40 8-15
- Item Master File Report–Complete–AMVE41 8-18
- Item Master File Report–Current or Standard Costs–AMVE42 8-20
- Item Master File Report–Purchase Item Description–AMVE44 8-24
- Item Master File Report–Purchase Item Detail–AMVE43 8-22
- Item Master offline data entry—C–record (PM-28) 9-13
- Item Master offline file maintenance—A–record form (PM-26A) 9-8, 9-11
- Item Master offline maintenance 6-181

Item Master Offline Maintenance (A-Record) form–PM-26A 6-181
 Item Master Offline Maintenance (A-Record) form–PM-26B 6-181
 Item Master Offline Maintenance (B-Record) form–PM-27 6-181
 Item Master Offline Maintenance (C-Record) form–PM-28 6-181
 Item Master Offline Maintenance Options display–AMEP55 6-182
 Item Master Report (Select) display–AMVE11 4-4
 item type 9 2-18, 2-22, 2-23
 ITMDKT file A-6

L

labor overhead
 costing options 5-2
 Labor/Overhead Table (Change) display–AMVX71 5-27, 5-30
 Labor/Overhead Table–Change Entry form–PM-13 9-15
 simulation 5-3
 Labor/Overhead Table–Change Entry form–PM-13 5-26, 5-29
 loading offline files A-2
 loading offline files into PDM A-3
 lower-level content 2-17
 low-level codes C-3, C-4

M

Main Menu options
 1-Demand Management 1-4
 2-Planning Run Options 1-4
 3-Planning and Financial Reports 1-4
 4-Order/Schedule Release and Review 1-4
 5-Calendar File Maintenance 1-4
 maintaining code files
 code file report 6-174
 definition 6-167
 how to add codes 6-177
 how to change code information 6-176
 how to delete codes 6-178
 how to end code file maintenance 6-179
 how to see a list of codes 6-175
 panels 6-171
 scrolling the code list 6-168
 maintenance audit trail
 description 6-3
 maintenance audit trail Production Facility file 6-85
 major reports listing 1-8
 Management Cost Summary–Current or Standard report–AMEH7 4-20
 managing Product Data Management
 before you begin 2-1
 controls 2-2
 sequence of operations 2-3
 source material 2-2
 tasks 2-1
 mass delete 2-12
 mass replace 2-12
 mass replacing components in product structures 6-42
 master file searches 1-7
 Master files 1-5
 master files 2-5
 description 1-5
 Item Foreign Language Description 6-162
 description 1-5
 Item Master

- description 1-6
- offline file names A-2
- Product Structure
 - description 1-6
- Production Facility
 - description 1-6
- Routing
 - description 1-6
- Routing Description
 - description 1-6
- searches 1-7
- Variable Capacity, description 1-7
- Master Production Schedule Planning 2-4
- Material Requirements Planning 2-5
- menus
 - MRP Main Menu-AMMM00 1-4
 - overview 1-4
- mfg overhead, cost calculations C-10
- milestone function 2-9
- Milestone Group Maintenance (MS-MAINT) display –AMEU79 6-123
- Milestone Group Maintenance (SAE MS–MNT) display–AMEU28 6-140
- MRP, general information
 - menus and displays, overview 1-4

N

- names for offline files A-2
- negative quantities 2-24

O

- offline files
 - creating A-1
 - data entry, description A-1
 - entering changes and deletions A-4
 - entering data A-2
 - format
 - description A-1
 - gathering information A-1
 - loading A-2
 - loading to PDM A-3
 - maintenance 6-180
 - Item Master 6-181
 - Item Master Offline Load Audit List–AMKE3 6-181
 - Item Master Offline Maintenance Edit List–AMKE1 6-181, A-3
 - options 6-1
 - Product Structure 6-184
 - Product Structure Offline Maintenance Edit List–AMEB0 10-4, A-3
 - Production Facility 6-186
 - Production Facility Offline Maintenance Edit List–AMVTE A-3
 - Routing 6-188
 - Routing Offline Maintenance Edit List–AMEB3 A-3
 - names A-2
 - processing A-4
 - Product Structure (PSDSKT) A-11
 - Production Facility (PFDSKT) A-12
 - Routing (RTGDKT) A-8
 - special data requirements A-3
 - using forms A-1
- online update
 - description 6-3

- description of 2-1
- Item Base Price file 6-1
- Item Foreign Language Descriptions file 6-3
- Item Master file 6-1, 6-3
- Item Master file maintenance 2-1
- Product Structure file 6-1
- Production Facility file 6-3
- Production Facility file maintenance 2-1
- Routing file 6-1
- operation yield
 - average 2-28
 - cumulative through previous operation 2-28
 - current 2-28
 - standard 2-28
 - total cumulative 2-28
- optional
 - features and options 2-13
 - Item Foreign Language 2-10
 - product costing 2-16
 - Production Facility 2-7
 - Routing 2-8
 - Routing Description 2-9
 - S-number 2-13
 - user sequence 2-16
- outside operations, cost calculations C-11

P

- PDM application
 - costing 2-16
 - file maintenance 2-11
 - flow of information between applications 1-1
 - information flow 1-1, 1-2
- percent changes
 - description 10-20
 - facility cost rates (simulation) 5-20
 - item cost percent change 10-20
 - material, by item class 5-24
 - Production Facility file 10-20
 - purchase content, by item class (simulation) 5-20
- percent changes, production facility cost rates 6-83
- permanent files
 - Item Foreign Language, description 1-5
 - Item Master 2-5
 - Item Master, description 1-6
 - master 1-5
 - Product Structure 2-6
 - Product Structure, description 1-6
 - Production Facility 2-7
 - Production Facility, description 1-6
 - Routing 2-8
 - Routing Description 2-9
 - Routing Description, description 1-6
 - Routing, description 1-6
 - System Control, description 1-5
 - transaction 1-5
 - Variable Capacity, description 1-7
- PFDSKT file A-12
- phantoms
 - costing roll up C-14
 - description C-14
 - single level explosion with blow-through C-1

versus features, description C-14
 PM-01 Item Master file maintenance, general information form 9-3
 PM-01–Item Master File Maintenance–General Information form 6-4
 PM-02 Item Master file maintenance—additional information form 9-4
 PM-02–Item Master File Maintenance–Additional Information form 6-4
 PM-03 Item Master file maintenance—costing information form 9-5
 PM-03–Item Master File Maintenance–Costing Information form 6-4
 PM-04 Item Master file maintenance—purchasing information form 9-6
 PM-04–Item Master File Maintenance–Purchasing Information form 6-4
 PM-13–Labor/Overhead Table–Change Entry form 5-26, 5-29, 9-15
 PM-14–Product Structure File Maintenance form 6-28, 9-16
 PM-15–Product Structure Offline Maintenance form 9-18
 PM-16–Purchase Overhead Table–Change Entry form 5-31, 5-34, 9-29
 PM-17–Routing File Maintenance form 6-100, 9-31
 PM-18–Routing File Milestone Group Maintenance form 6-100, 9-33
 PM-21–Routing Description File Maintenance–Additional Operation Descriptions
 form 6-100, 9-35
 PM-23–Production Facility File Maintenance form 6-73
 PM-23–Production Facility Maintenance form (AMVT7) 9-39
 PM-26A Item Master offline file maintenance—A–record form 9-8, 9-11
 PM-26A–Item Master Offline Maintenance (A-Record) form 6-181
 PM-26B–Item Master Offline Maintenance (A-Record) form 6-181
 PM-27–Item Master Offline Maintenance (B-Record) form 6-181
 PM-28 Item Master offline data entry—C–record form 9-13
 PM-28–Item Master Offline Maintenance (C-Record) form 6-181
 PM-29–Routing File Offline Maintenance form 9-37
 PM-30A–Production Facility Offline Maintenance form 9-41
 PM-30B–Production Facility Offline Maintenance form 9-42
 primary interface considerations 1-1
 printing reports
 Bills of Material 4-9, 4-20
 Calculate Adjusted Quantity Per 7-3
 Calculate Cumulative Yield 7-2
 Costing Variations 4-20
 description 4-1
 Feature/Options 4-8
 Item Foreign Language Descriptions 4-28
 Item Master 4-3
 Item Master File Maintenance 6-4
 Item Master Offline Load Audit List 6-181
 Item Master Offline Maintenance Edit List 6-181
 Management Cost Summary 4-20
 options 4-1
 Product Costing 5-4
 Product Costing Simulation–Current or Standard 5-7
 Product Structure 4-9, 4-20
 Product Structure Transaction List 6-28
 Production Facility 4-9
 Production Facility by Department 4-7
 Production Facility by Facility 4-6
 Production Facility Maintenance 6-73
 Retrieval Selections–Costed 4-20
 Retrieval Selections–Regular 4-9
 Routing Transaction List 6-100
 Routings 4-9, 4-20
 Variable Capacity Master File Maintenance 6-73
 Work-in-Process 4-25
 processing offline files A-4
 Product Cost Simulation–Change by Facility (Enter) display–AMEJ75 5-16
 Product Cost Simulation–Change by Facility (Review) display–AMEJ76 5-18
 Product Cost Simulation–Change by Facility (Select) display–AMEJ74 5-15
 Product Cost Simulation–Change by Percent (Enter) display–AMEJ77 5-20
 Product Cost Update Report–Current or Standard Costs–AMEI30 8-73
 product costing

changing Labor/Overhead Table 5-27, 5-30
 changing Purchase Overhead Table 5-32, 5-35
 cost elements 2-17
 cost roll-up 2-22
 cost technique codes 2-20
 current cost 2-16
 current unit cost 2-17
 description of 2-16
 displays

- Costed Reports–Costed–Multi List (Select)–AMEF44 4-23
- Costed Reports–Costed–Single List (Select)–AMEF43 4-21
- Item Cost Percent Change (Chang%)–AMET50 5-24
- Labor/Overhead Table (Change)–AMVX71 5-27, 5-30
- Product Cost Simulation (Select)–AMEJ70 5-8
- Product Cost Simulation–Change by Facility (Enter)–AMEJ75 5-16
- Product Cost Simulation–Change by Facility (Review)–AMEJ76 5-18
- Product Cost Simulation–Change by Facility (Select)–AMEJ74 5-15
- Product Cost Simulation–Change by Item (Enter)–AMEJ72 5-11
- Product Cost Simulation–Change by Item (Review)–AMEJ73 5-13
- Product Cost Simulation–Change by Item (Select)–AMEJ71 5-10
- Product Cost Simulation–Change by Percent (Enter)–AMEJ77 5-20
- Product Costing (Select)–AMEJ78 5-5
- Purchase Overhead Table (Change)–AMVX72 5-32

 feature items 2-18, 2-19
 features C-14
 formulas for CTECH=R C-7
 full 5-3
 full and selective costing, relationship 2-24
 full costing 2-24
 impact of operation yield 2-30
 information flow with other applications 1-2
 information security 1-8
 Item Master file maintenance 2-18
 low-level codes C-3
 options 5-2
 phantoms C-14
 Product Structure file maintenance 2-17
 recost flag 2-25
 reports

- Cost Variations–Current to Standard–AMEH8 4-20, 8-61
- Indented Cost Sheet–Current or Standard–AMEG72 4-20, 8-64
- Item Cost Percent Change Audit report–AMET5 5-23
- Management Cost Summary–Current or Standard–AMEH7 8-67
- Management Cost Summary–Current or Standard–AMEH7 4-20
- Product Cost Simulation—Curr and Std Costs or Aver Costs After Chg By Percent (AMEI31) 8-75
- Product Cost Simulation–Current or Standard–AMEI31 5-7
- Product Cost Update Report–Current or Standard Costs–AMEI30 5-4, 8-73
- Routing Operation and Single Level Cost Sheet–Current–AMEH41 4-20, 8-69
- Routing Operation and Single Level Cost Sheet–Standard–AMEH42 4-20, 8-69
- Single Level Cost Sheet—Curr or Std, Single or Multi-Item, with or w/out Blow-thr–AMEG71 8-78

 rolling costs from current to standard 5-37
 roll-up, description C-12
 Routing file maintenance 2-17
 selective 5-3
 selective and full costing, relationship 2-24
 simulation

- by costing date 5-9
- by percent 5-20
- current and standard cost 5-1
- current cost 5-1, 5-3

- description 5-1, 5-3
- Labor/Overhead Simulation Table 5-27, 5-30
- options 5-2
- Purchase Overhead Simulation Table 5-32, 5-35
- standard cost 5-1, 5-3
- using average yield 5-9
- special items 2-18
- standard cost 2-16
- standard unit cost 2-17
- unit cost 2-17
- Product Costing (Select) display–AMEJ78 5-5
- Product Data Management information flow 1-1
- Product Structure Data Entry Control display–AMEUA1 2-1
- Product Structure edit/load 10-4
- Product Structure Extract file (PSEXTR) 1-7
- Product Structure file
 - adding component items 6-35
 - adding SAE component items 6-60
 - audit trail 10-10
 - building a bill of material 9-19
 - changing component items 6-40
 - changing SAE component items 6-56
 - continuity checking C-4
 - controls when loading 10-4
 - copying a product structure 6-53
 - cost elements 2-17
 - data entry forms used 2-6
 - delete structure 2-12
 - deleting component items 6-44
 - deleting SAE component items 6-58
 - deleting structures 6-49
 - description 1-6, 6-3
 - end-item where-used implosion C-2
 - file maintenance 6-1
 - indented explosion C-1, C-3
 - indented implosion C-3
 - level tables C-3
 - low-level codes C-3
 - maintenance 6-28
 - mass delete 2-12
 - mass deleting component items 6-46
 - mass replace 2-12
 - mass replacing component items 6-42
 - offline data entry forms used 2-6
 - offline file (PSDSKT) A-11
 - offline maintenance 6-184
 - prerequisites 2-6
 - reorganization 10-17
 - report printed after reorganization 10-17
 - reports
 - descriptions 1-8–1-9
 - End-Item Where-Used–AMEF75 4-9
 - Indented Bill–AMEF72 4-9
 - Indented Cost Sheet–Current or Standard–AMEG72 4-20
 - options 4-2
 - printed after file maintenance 6-3
 - Product Structure Offline Maintenance Edit List–AMEB0 10-4, A-3
 - Product Structure Transaction List–AMEU5 6-28, 8-32
 - Routing and Single Level Retrieval with Blow-Through–AMEG4 4-9
 - Single Level Bill with Blow-Through–AMEF71 4-9, 8-35
 - Single Level Cost Sheet—Curr or Std, Single or Multi-Item, with or w/out Blow-thr–AMEG71 4-20
 - Single Level Where-Used–AMEF74 4-9, 8-37
 - Summarized Bill–AMEF73 4-9, 8-38

- reports printed after batch update 10-10
- reviewing
 - parent item product structure 6-71
 - transaction detail 6-66
 - transactions 6-64
- same-as-except (SAE) 2-12
- single level
 - explosion C-1
 - explosion with blow-through C-1
 - implosion C-2
- summarized explosion C-1
- update method 2-1
- updating 6-32-6-71
- Product Structure File Maintenance (Add/Review) display-AMEU12 6-35
- Product Structure File Maintenance (Batch Status) display-AMEU18 6-51
- Product Structure File Maintenance (Batch Status) display-AMEU35 6-62
- Product Structure File Maintenance (Change/Review) display-AMEU13 6-40
- Product Structure File Maintenance (Delete/Review) display-AMEU15 6-44
- Product Structure File Maintenance (Mass Delete/Review) display-AMEU16 6-46
- Product Structure File Maintenance (Mass Replace/Review) display-AMEU14 6-42
- Product Structure File Maintenance (Review) display-AMEU41 6-64
- Product Structure File Maintenance (Review) display-AMEU42 6-66
- Product Structure File Maintenance (Review) display-AMEUG1 6-71
- Product Structure File Maintenance (SAE Add) display-AMEU34 6-60
- Product Structure File Maintenance (SAE Change) display-AMEU32 6-56
- Product Structure File Maintenance (SAE Delete) display-AMEU33 6-58
- Product Structure File Maintenance (SAE Header) display-AMEU31 6-53
- Product Structure File Maintenance (Select) display-AMEU11 6-32
- Product Structure File Maintenance (Structure Delete/Review) display-AMEU17 6-49
- Product Structure File Maintenance form-PM-14 6-28, 9-16
- Product Structure File Maintenance, Batch Status display-AMEU43 6-69
- Product Structure File Maintenance-Data Entry Control display-AMEUA1 6-29
- Product Structure offline file maintenance 6-184
- Product Structure Offline Maintenance form-PM-15 9-18
- Product Structure Offline Maintenance Options display-AMEP57 6-185
- Product Structure Retrievals (Select) display-AMEC70 3-4, 3-8
- Product Structure Transaction Update file (PSUPDT) 1-7
- Production Control and Costing 2-4
- Production Facility
 - (Select) display-AMVD60 3-40
 - file
 - adding a record 6-76
 - audit trail 6-85
 - changing a record 6-81
 - deleting a record 6-82
 - percent change of cost rates 6-83
 - Inquiry display-AMVD61 3-41
 - Maintenance (Add) display-AMVT71 6-76
 - Maintenance (Change %) display-AMVT74 6-83
 - Maintenance (Change) display-AMVT72 6-81
 - Maintenance (Select) display-AMVT70 6-74
 - Maintenance report-AMVT7 8-39
 - Maintenance, (Delete) display-AMVT73 6-82
- reports
 - Variable Capacity File Maintenance-AMVTC 8-51
- production facility
 - defined 2-7
 - work station 1-2, 2-1
 - work station security 1-7
- Production Facility file
 - audit trail 10-12, 10-13
 - data entry form used 2-7, 9-39
 - description 1-6, 6-3

- maintenance 6-73
- maintenance audit trail 10-12, 10-13
- offline file (PFDSKT) A-12
- offline maintenance 6-186
- percent changes 10-20
- percent changes (audit trail) 10-20
- prerequisites 2-7
- report printed 10-12, 10-13
- report printed after percent changes 10-20
- reports
 - descriptions 1-8
 - options 4-1
 - printed after file maintenance 6-3
 - Production Facility Maintenance-AMVT7 6-73
 - Production Facility Offline Maintenance Edit List-AMVTE A-3
 - Production Facility Where-Used-AMEG12 4-9, 8-48
 - Production Facility-Sequenced by Facility or Department-AMEE7 4-6, 4-7
- routing retrievals C-2
- update method 2-1
- where-used retirevals C-2
- Production Facility File Maintenance form-PM-23 6-73
- Production Facility maintenance , form-PM-23 9-39
- Production Facility offline file maintenance 6-186
- Production Facility Offline Maintenance form-PM-30A 9-41
- Production Facility Offline Maintenance form-PM-30B 9-42
- Production Facility Offline Maintenance Options display-AMEP5L 6-187
- Production Facility Report-Sequenced by Facility-AMV43 8-44
- Production Facility Where-Used report-AMEG12 4-9
- Production Monitoring and Control 2-5
- PSDSKT file A-11
- Purchase Overhead Table
 - changing Costing Table 5-32, 5-35
 - changing Simulation Table 5-32, 5-35
 - Purchase Overhead Table-Change Entry form-PM-16 9-29
 - simulation 5-3
- Purchase Overhead Table (Change) display-AMVX72 5-32, 5-35
- Purchase Overhead Table-Change Entry form-PM-16 5-31, 5-34
- purchased items 2-18
- Purchasing 2-5

Q

- quantities, negative 2-24
- quantity per, adjusted 2-29
- quantity, standard batch 2-27

R

- records in use 1-7
- recost flag 2-25
- reorganizing files
 - Product Structure 10-17
 - Product Structure file report printed 10-17
 - Product Structure file, audit trail 10-17
 - Routing 10-18
 - Routing Description 10-19
 - Routing Description file report printed 10-19
 - Routing Description file, audit trail 10-19
 - Routing file report printed 10-18
 - Routing file, audit trail 10-18
- Repetitive Production Management 2-5

replacing components in product structures 6-42

report by ID

- Cost Variations—Current to Standard 8-1
- End-Item Where-Used 8-1
- Feature/Options Report 8-1
- Indented Bill 8-1
- Indented Cost Sheet—Current or Standard 8-1
- Item Master File Maintenance 8-1
- Item Master File Report—Brief 8-1
- Item Master File Report—Complete 8-1
- Item Master File Report—Current or Standard Costs 8-1
- Item Master File Report—Purchase Item Description 8-1
- Item Master File Report—Purchase Item Detail 8-1
- Management Cost Summary—Current or Standard 8-1
- Product Cost Simulation—Current and Standard Costs or Average Costs 8-1
- Product Cost Update Report—Current or Standard Costs 8-1
- Product Structure Transaction List 8-1
- Production Facility Maintenance 8-1
- Production Facility Where-Used 8-1
- Routing and Single Level Retrieval with Blow-Through 8-1
- Routing List 8-1
- Routing Operation and Single Level Cost Sheet—Current or Standard 8-1
- Routing Transaction List 8-1
- Single Level Bill with Blow-Through 8-1
- Single Level Cost Sheet—Current or Standard 8-1
- Single Level Where-Used 8-1
- Summarized Bill 8-1
- Work-in-Process Cost Worksheet—Current, Standard, or Average Costs 8-2

report displays

- Costed Reports—Costed—Multi List (Select)—AMEF44 4-23
- Costed Reports—Costed—Single List (Select)—AMEF43 4-21
- Item Foreign Language Descriptions—AMEPT8 4-29
- Item Master Report (Select)—AMVE11 4-4
- Retrieval Selections—Regular—Multi-list (Select)—AMEF42 4-12
- Retrieval Selections—Regular—Single List (Select) display—AMEF41 4-10
- Retrieval Selections—Regular—Single List (Select) display—AMEF45 4-14
- Retrieval Selections—Regular—Single List (Select) display—AMEF46 4-16
- Retrieval Selections—Regular—Single List (Select) display—AMEF47 4-18
- WIP Cost Worksheet (Select)—AME751 4-26

reports

- Calculate Adjusted Quantity Per—AME82 7-3, 8-90
- Calculate Cumulative Yield—AME78 7-2, 8-87
- Cost Variations—Current to Standard—AMEH8 4-20, 8-61
- descriptions 1-8-1-9
- End-Item Where-Used —AMEF75 8-25
- End-Item Where-Used—AMEF75 4-9
- Feature/Options Report—AMEF1 8-27
- Feature/Options—AMEF1 4-8
- Indented Bill—AMEF72 4-9, 8-30
- Indented Cost Sheet—Current or Standard—AMEG72 4-20, 8-64
- Item Cost Percent Change Audit report—AMET5 5-23
- Item Master File Maintenance—AMVT0 6-4, 8-3
- Item Master File Report—Brief—AMVE40 4-3
- Item Master File Report—Brief—AMVE40 8-15
- Item Master File Report—Complete—AMVE41 4-3
- Item Master File Report—Complete—AMVE41 8-18
- Item Master File Report—Current or Standard Costs—AMVE42 4-3
- Item Master File Report—Current or Standard Costs—AMVE42 8-20
- Item Master File Report—Purchase Item Description 8-24
- Item Master File Report—Purchase Item Description—AMVE44 4-3
- Item Master File Report—Purchase Item Detail 8-22
- Item Master File Report—Purchase Item Detail—AMVE43 4-3
- Item Master Offline Load Audit List—AMKE3 6-181
- Item Master Offline Maintenance Edit List—AMKE1 6-181, A-3

Items with Foreign Language Descriptions–AMVD1PFR 4-28
 Items without Foreign Language Descriptions –AMVDYPFR 4-28
 Management Cost Summary–Current or Standard–AMEH7 4-20, 8-67
 Product Cost Simulation—Curr and Std Costs or Aver Costs After Chg By Percent
 (AMEI31) 8-75
 Product Cost Simulation–Current or Standard–AMEI31 5-7
 Product Cost Update Report–Current or Standard Costs–AMEI30 5-4, 8-73
 Product Structure Offline Maintenance Edit List–AMEB0 10-4, A-3
 Product Structure Transaction List–AMEU5 6-28, 8-32
 Production Facility Maintenance Report–AMVT7 8-39
 Production Facility Maintenance–AMVT7 6-73
 Production Facility Offline Maintenance Edit List–AMVTE A-3
 Production Facility Where-Used–AMEG12 4-9, 8-48
 Production Facility–Sequenced by Facility or Department–AMEE7 4-6, 4-7
 Routing and Single Level Retrieval with Blow-Through–AMEG4 4-9, 8-52
 Routing List–AMEG11 4-9, 8-57
 Routing Offline Maintenance Edit List–AMEB3 A-3
 Routing Operation and Single Level Cost Sheet–Current–AMEH41 4-20, 8-69
 Routing Operation and Single Level Cost Sheet–Standard–AMEH42 4-20, 8-69
 Routing Transaction List–AMEU9 6-100, 8-59
 Single Level Bill with Blow-Through–AMEF71 4-9, 8-35
 Single Level Cost Sheet—Curr or Std, Single or Multi-Item, with or w/out Blow-
 thr–AMEG71 4-20, 8-78
 Single Level Where-Used–AMEF74 4-9, 8-37
 Summarized Bill–AMEF73 4-9, 8-38
 Variable Capacity File Maintenance–AMVTC 8-51
 Variable Capacity Master File Maintenance–AMVTC 6-73
 Work-in-Process Cost Worksheet–Current, Standard, or Average Costs–AME86
 4-25, 8-82
 reports by ID
 AME78-Calculate Cumulative Yield 8-87
 AME82-Calculate Adjusted Quantity Per 8-90
 AME86-Work-in-Process Cost Worksheet—Current, Standard, or Average Costs
 8-82
 AMEF1- Feature/Options Report 8-27
 AMEF71-Single Level Bill with Blow-Through 8-35
 AMEF72-Indented Bill 8-30
 AMEF73-Summarized Bill 8-38
 AMEF74-Single Level Where-Used 8-37
 AMEF75- End-Item Where-Used 8-25
 AMEG11-Routing List 8-57
 AMEG12-Production Facility Where-Used 8-48
 AMEG4-Routing and Single Level Retrieval with Blow-Through 8-52
 AMEG71-Single Level Cost Sheet—Curr or Std, Single or Multi-Item, with or w/
 out Blow-thr 8-78
 AMEG7-Indented Cost Sheet—Current or Standard 8-64
 AMEH7-Management Cost Summary–Current or Standard report 8-67
 AMEH8-Cost Variations—Current to Standard 8-61
 AMEI30-Product Cost Update Report—Current or Standard Costs 8-73
 AMEI31-Product Cost Simulation—Curr and Std Costs or Aver Costs After Chg
 By Percent 8-75
 AMEU5-Product Structure Transaction List 8-32
 AMEU9-Routing Transaction List 8-59
 AMV43–Production Facility Report–Sequenced by Facility 8-44
 AMVE40 -Item Master File Report—Brief 8-15
 AMVE41-Item Master File Report—Complete 8-18
 AMVE42-Item Master File Report—Current or Standard Costs 8-20
 AMVE43-Item Master File Report—Purchase Item Detail 8-22
 AMVE44-Item Master File Report—Purchase Item Description 8-24
 AMVT0-Item Master File Maintenance 8-3
 AMVT7-Production Facility Maintenance 8-39
 AMVTC-Variable Capacity File Maintenance 8-51
 Calculate Adjusted Quantity Per 8-1
 Calculate Cumulative Yield 8-1

- required files
 - Item Master 2-5
 - Product Structure 2-6
- retrieval information C-1
- Retrieval Selections–Regular–Multi-list (Select) display–AMEF42 4-12
- Retrieval Selections–Regular–Single List (Select) display–AMEF41 4-10
- Retrieval Selections–Regular–Single List (Select) display–AMEF45 4-14
- Retrieval Selections–Regular–Single List (Select) display–AMEF46 4-16
- Retrieval Selections–Regular–Single List (Select) display–AMEF47 4-18
- retrievals
 - end-item where-used implosion C-2
 - indented explosion C-1, C-3
 - indented implosion C-3
 - level tables C-3
 - production facility where-used routine C-2
 - routing operations C-2
 - single level explosion C-1
 - single level explosion with blow-through C-1
 - single level implosion C-2
 - summarized explosion C-1
- review displays
 - Product Cost Simulation–Change by Facility (Review)–AMEJ76 5-18
 - Product Cost Simulation–Change by Item (Review)–AMEJ73 5-13
 - Product Structure File Maintenance (Add/Review)–AMEU12 6-35
 - Product Structure File Maintenance (Change/Review)–AMEU13 6-40
 - Product Structure File Maintenance (Delete/Review)–AMEU15 6-44
 - Product Structure File Maintenance (Mass Delete/Review)–AMEU16 6-46
 - Product Structure File Maintenance (Mass Replace/Review)–AMEU14 6-42
 - Product Structure File Maintenance (Review)–AMEU41 6-64
 - Product Structure File Maintenance (Review)–AMEU42 6-66
 - Product Structure File Maintenance (Review)–AMEUG1 6-71
 - Product Structure File Maintenance (Structure Delete/Review)–AMEU17 6-49
 - Routing File Maintenance (Add/Review)–AMEU72 6-106
 - Routing File Maintenance (Change/Review)–AMEU73 6-112
 - Routing File Maintenance (Review)–AMEU81 6-142
 - Routing File Maintenance (Review)–AMEU82 6-144
 - Routing File Maintenance (Review)–AMEU84 6-150
 - Routing File Maintenance (Review)–AMEU85 6-152
 - Routing File Maintenance (Review)–AMEUK1 6-154
- Roll Current to Standard Costs display–AMEJ80 5-37
- Routing Description file
 - adding additional descriptions 6-121
 - adding additional descriptions (SAE) 6-137
 - changing additional descriptions 6-121
 - changing additional descriptions (SAE) 6-137
 - creating 2-9
 - deleting additional descriptions 6-121
 - deleting additional descriptions (SAE) 6-137
 - description 1-6, 6-3
 - description of 2-9
 - functions and calculations 2-9
 - maintenance audit trail 10-14
 - PDM file relationships, summary 2-10
 - reorganization 10-19
 - reports
 - printed after file maintenance 6-3
 - printed after reorganization 10-19
 - retrievals C-2
- Routing Description File Maintenance–Additional Operation Descriptions form–PM-21 6-100, 9-35
- Routing edit/load 10-5
- Routing file
 - adding operations 6-106
 - adding routing operations (SAE) 6-133

- application tailoring requirements 6-100
- audit trail 10-14
- changing operations 6-112
- changing routing records (SAE) 6-129
- controls when loading 10-5
- cost elements 2-17
- defining milestone groups 6-123
- defining milestone groups (SAE) 6-140
- deleting operations 6-114
- deleting routing records (SAE) 6-131
- deleting routings 6-116
- description 1-6, 6-3
- file maintenance 6-1
- maintenance 6-100
- maintenance audit trail 10-14
- offline file (RTGDKT) A-8
- offline maintenance 6-188
- removing milestone groups 6-123
- removing milestone groups (SAE) 6-140
- reorganization 10-18
- reports
 - printed after batch update 10-14
 - printed after file maintenance 6-3
 - printed after reorganization 10-18
 - Routing and Single Level Retrieval with Blow-Through-AMEG4 4-9, 8-52
 - Routing List-AMEG11 4-9, 8-57
 - Routing Offline Maintenance Edit List-AMEB3 A-3
 - Routing Operation and Single Level Cost Sheet-Current-AMEH41 4-20
 - Routing Operation and Single Level Cost Sheet-Standard-AMEH42 4-20
 - Routing Transaction List-AMEU9 6-100, 8-59
- retrievals C-2
- routing delete 2-12
- same-as-except (SAE) 2-12, 6-125
- update method 2-1
- updating 6-104-6-123
- Routing File Maintenance (Add/Review) display-AMEU72 6-106
- Routing File Maintenance (Batch Status) display-AMEU26 6-135
- Routing File Maintenance (Batch Status) display-AMEU77 6-118
- Routing File Maintenance (Batch Status) display-AMEU83 6-148
- Routing File Maintenance (Change/Review) display-AMEU73 6-112
- Routing File Maintenance (Delete) display-AMEU75 6-114
- Routing File Maintenance (MS-MAINT) display-AMEU79 6-123
- Routing File Maintenance (Review) display-AMEU81 6-142
- Routing File Maintenance (Review) display-AMEU82 6-144
- Routing File Maintenance (Review) display-AMEU84 6-150
- Routing File Maintenance (Review) display-AMEU85 6-152
- Routing File Maintenance (Review) display-AMEUK1 6-154
- Routing File Maintenance (Routing Delete) display-AMEU76 6-116
- Routing File Maintenance (SAE Add) display-AMEU24 6-133
- Routing File Maintenance (SAE Add Desc Maint) display-AMEU27 6-137
- Routing File Maintenance (SAE Delete) display-AMEU23 6-131
- Routing File Maintenance (SAE Header) display-AMEU21 6-125
- Routing File Maintenance (SAE MS-MNT) display-AMEU28 6-140
- Routing File Maintenance (Select) display-AMEU71 6-104
- Routing File Maintenance (Update) display-AMEU78 6-121
- Routing File Maintenance form-PM-17 6-100, 9-31
- Routing File Maintenance, SAE Change display-AMEU22 6-129
- Routing File Maintenance-Data Entry Control display-AMEU61 6-101
- Routing File Milestone Group Maintenance form-PM-18 6-100, 9-33
- Routing File Offline Maintenance form-PM-29 9-37
- Routing offline file maintenance 6-188
- Routing Operation and Single Level Cost Sheet-Current-AMEH41 8-69
- Routing Operation and Single Level Cost Sheet-Standard-AMEH42 8-69
- Routing Operation Description (Inquiry) display,-AMED46 3-37

- routing operations
 - description of 2-11
 - retrievals C-2
- Routing Operations (Inquiry) display—AMED41 3-32
- Routing Operations (Select) display—AMED40 3-31
- Routing Transaction Update file (RTUPDT) 1-7
- RTGDKT file A-8
- run hours, adjusted 2-30

S

- same-as-except (SAE)
 - adding component items 6-60
 - adding routing operation (SAE) 6-133
 - changing component items 6-56
 - changing routing records (SAE) 6-129
 - copying product structures 6-53
 - deleting component items 6-58
 - deleting routing records (SAE) 6-131
 - description 6-100
 - displays
 - Product Structure File Maintenance (Batch Status)—AMEU35 6-62
 - Product Structure File Maintenance (SAE Add)—AMEU34 6-60
 - Product Structure File Maintenance (SAE Change)—AMEU32 6-56
 - Product Structure File Maintenance (SAE Delete)—AMEU33 6-58
 - Product Structure File Maintenance (SAE Header)—AMEU31 6-53
 - Routing File Maintenance (Batch Status)—AMEU26 6-135
 - Routing File Maintenance (Review)—AMEU81 6-142
 - Routing File Maintenance (Review)—AMEU82 6-144
 - Routing File Maintenance (Review)—AMEU84 6-150
 - Routing File Maintenance (Review)—AMEU85 6-152
 - Routing File Maintenance (Review)—AMEUK1 6-154
 - Routing File Maintenance (SAE Add)—AMEU24 6-133
 - Routing File Maintenance (SAE Addl Desc Maint)—AMEU27 6-137
 - Routing File Maintenance (SAE Delete)—AMEU23 6-131
 - Routing File Maintenance (SAE Header)—AMEU21 6-125
 - Routing File Maintenance (SAE MS—MNT)—AMEU28 6-140
 - Routing File Maintenance, SAE Change—AMEU22 6-129
 - product structure 2-12
 - routing 2-12, 6-125
- security
 - description 1-7
 - password 1-7
 - product costing 1-8
- selective costing
 - cost status code 2-25
 - description 5-3
 - description of 2-24
- sequence, user 2-16
- shrinkage 2-29
- Simulation Transactions file (SIMXAC). 1-7
- single level
 - explosion C-1
 - explosion with blow-through C-1
 - implosion C-2
- Single Level Bill of Material (Inquiry) display—AMEC71 3-5, 3-10
- Single Level Bill With Blow-Through (Inquiry) display—AMEC74 3-19
- Single Level Bill with Blow-Through report—AMEF71 4-9, 8-35
- Single Level Cost Sheet—Curr or Std, Single or Multi-Item, with or w/out Blow-thr report—AMEG71 4-20, 8-78
- Single Level Costed (Select) display—AMEC40 3-23
- Single Level Costed—Current (Inquiry) display—AMEC41 3-25

Single Level Costed–Standard (Inquiry) display–AMEC42 3-29
 Single Level Where-Used (Inquiry) display–AMEC73 3-16
 Single Level Where-Used report–AMEF74 4-9, 8-37
 S-number
 description C-13
 end-item C-13
 FOTAB1 C-13
 processing C-13
 special maintenance transactions 2-12
 special requirements for offline files A-3
 standard , simulation 2-16
 standard batch quantity 2-27
 standard cost
 description 5-1
 simulation 5-3
 standard unit cost 2-17
 status, batch 2-1
 Summarized Bill–AMEF73 4-9, 8-38
 summarized explosion C-1
 System Control File
 description 1-5
 features/options template C-13

T

t 2-1
 tasks, determine 2-1
 this-level , content 2-22
 TM-01–Variable Capacity Master File Maintenance form 6-73, 9-44
 transaction files
 description 1-5
 reuse of 2-2
 Routing Transaction Maintenance 1-5

U

unit cost 2-17
 update methods
 batch 2-1
 close batch 2-1
 immediate 2-1
 online 2-1
 updated batch 2-1
 Updating the PDM Control file 6-190
 user sequence 2-16

V

Variable Capacity
 file
 adding a record 6-89
 changing a record 6-92
 deleting a record 6-94
 deleting all records 6-96
 updating 6-87–6-98
 File Maintenance report–AMVTC 8-51
 Maintenance
 (Add) display–AMVTC2 6-89
 (Change) display–AMVTC3 6-92
 (Delete All) display–AMVTC5 6-96

- (Delete) display–AMVTC4 6-94
- (Select) display–AMVTC1 6-87
- (Status) display–AMVTC6 6-98
- Variable Capacity file
 - description 1-7
 - Variable Capacity Master File Maintenance report–AMVTC 6-73
- Variable Capacity Master File Maintenance form–TM-0 9-44
- Variable Capacity Master File Maintenance form–TM-01 6-73

W

- WIP Cost Worksheet (Select) display–AME751 4-26
 - work files, description 1-7
- Work-in-Process Cost Worksheet–Current, Standard, or Average Costs–AME86 4-25, 8-82

Y

- yields
 - adjusted quantity per 7-3
 - calculating 7-1
 - cumulative 7-2
 - reports
 - Calculate Adjusted Quantity Per–AME82 7-3, 8-90
 - Calculate Cumulative Yield–AME78 7-2, 8-87