



Infor XA – Master Production Schedule Planning User's Guide

Important Notices

The material contained in this publication (including any supplementary information) constitutes and contains confidential and proprietary information of Infor.

By gaining access to the attached, you acknowledge and agree that the material (including any modification, translation or adaptation of the material) and all copyright, trade secrets and all other right, title and interest therein, are the sole property of Infor and that you shall not gain right, title or interest in the material (including any modification, translation or adaptation of the material) by virtue of your review thereof other than the non-exclusive right to use the material solely in connection with and the furtherance of your license and use of software made available to your company from Infor pursuant to a separate agreement, the terms of which separate agreement shall govern your use of this material and all supplemental related materials ("Purpose").

In addition, by accessing the enclosed material, you acknowledge and agree that you are required to maintain such material in strict confidence and that your use of such material is limited to the Purpose described above. Although Infor has taken due care to ensure that the material included in this publication is accurate and complete, Infor cannot warrant that the information contained in this publication is complete, does not contain typographical or other errors, or will meet your specific requirements. As such, Infor does not assume and hereby disclaims all liability, consequential or otherwise, for any loss or damage to any person or entity which is caused by or relates to errors or omissions in this publication (including any supplementary information), whether such errors or omissions result from negligence, accident or any other cause.

Without limitation, U.S. export control laws and other applicable export and import laws govern your use of this material and you will neither export or re-export, directly or indirectly, this material nor any related materials or supplemental information in violation of such laws, or use such materials for any purpose prohibited by such laws.

Trademark Acknowledgements

The word and design marks set forth herein are trademarks and/or registered trademarks of Infor and/or related affiliates and subsidiaries. All rights reserved. All other company, product, trade or service names referenced may be registered trademarks or trademarks of their respective owners.

Publication Information

Release: Infor XA 10

Publication date: August, 2021

To the reader

This book contains the information you need to understand and run this application. The information in this book applies only to MAPICS XA.

For a complete list of the books in the MAPICS XA library, see the bibliography on the MAPICS XA documentation CD.

Before you begin

If you are not familiar with the AS/400, please complete the AS/400 system education for the basic operating concepts of the AS/400 system.

What this book contains

Chapters 1 and 2 acquaint you with the application. Be sure to read the first two chapters before you use the instructions in the remaining sections. Use these chapters to understand how this application works and what you need to know to manage it.

The next group of chapters describes the options on the Main Menu. For example, Chapter 3 contains information about option 1 of the Main Menu. Each chapter includes information about how to use the displays associated with each option.

The last group of chapters describes the reports and forms for this application.

Use the appendixes to find information about using other functions specific to your application.

Summary of changes

This book has been modified to include information regarding Enabling access to Enterprise Product Data Management (EPDM).

Changes have been made to existing MAPICS applications to enable them to access and use files managed by Enterprise Product Data Management (EPDM). Access to EPDM files (BoM, Routings, Facility Master) for all MAPICS applications has been enabled.

PDM is no longer a prerequisite application when EPDM is activated.

Contents

To the reader	iii
Before you begin	iii
What this book contains	iii
Summary of changes	iv
Chapter 1. Introducing Master Production Schedule Planning	1-1
What Master Production Schedule Planning does	1-2
MPSP and the business processes	1-3
The MPSP Main Menu	1-9
Major functions	1-10
How the information flows within Master Production Schedule Planning	1-12
How MPSP works with other applications	1-15
Master Production Schedule Planning interfaces	1-17
How MPSP works with MRP	1-18
How MPSP works with EPDM	1-19
How MPSP works with ISL/MISL	1-20
How the application is designed	1-22
Data entry and update methods	1-22
Concurrent use of MPSP files	1-22
Files	1-23
Major reports	1-30
Inquiries	1-30
Master file queries and searches	1-31
Using eWorkPlace with MAPICS XA documentation	1-31
Chapter 2. Managing Master Production Schedule Planning	2-1
Before you begin Master Production Schedule Planning operations	2-1
Production planning	2-2
Creating and maintaining production families	2-2
Developing production plans	2-4
Performing aggregation activities	2-6
Developing family production targets	2-16
Testing production family resources	2-20
Developing and adjusting the item trial plans	2-20
Replacing item production plans	2-22
Evaluating family production plans	2-23
Master schedule planning	2-27
MPSP planning horizons	2-28
Composition of master production schedules	2-33
Preparing for master production schedule generation	2-34
Defining master scheduled items	2-36
Types of demand used in master scheduling	2-41
Current demand information for planning orders (extraction)	2-46
Planning and demand warehouses	2-49
Multi-warehouse planning	2-50
Using requisitions in planning	2-57
Planning orders	2-57
Maintaining master scheduled orders	2-62
Exception codes for maintaining orders and requisitions	2-65
Releasing orders	2-68
Time fences and planning zones	2-69

Consuming forecasts (CRPLB and CRPLA)	2-72
Resource planning	2-74
Preparing for resource testing	2-75
Critical resources	2-76
Generating resource profiles	2-77
Exploding the bill of material	2-84
Calculating the total time for a work center	2-93
Calculating resource values	2-98
Using the resource conversion factor	2-99
Correcting lead times	2-101
Correcting lot or batch sizes	2-102
Testing resources	2-102
Available to promise (ATP)	2-108
Available to promise in MPSP	2-108
Available to promise horizon	2-108
Demand and supply quantities in ATP	2-109
How MPSP calculates available to promise	2-110
Chapter 3. Production Planning	3-1
Option 1. Aggregate to Production Families (AMLM10)	3-4
AMV3HL—Aggregate to Production Families	3-5
AMV3A0—Aggregate to Production Families (Confirm)	3-7
Option 2. Display and Maintain Family Operating Plans (AMLM10)	3-8
AML201—Display/Maintain Family Operating Plans Selection	3-9
AML202—Display/Maintain Family Operating Plans	3-12
AML203—Family Operating Plan Detail	3-18
AML204—Daily Rates	3-22
Option 3. Test Family Operating Plan Resources (AMLM10)	3-26
AMV3HR—Test Family Operating Plan Resources	3-27
AML541—Test Family Operating Plan Resources Selection	3-29
Option 4. Display Resource Requirements (AMLM10)	3-31
AML531—Resource Requirements Selection	3-32
AML532—Resource Requirements Analysis	3-35
AML533—Resource Requirements Detail	3-38
Option 5. Display and Maintain Item Trial Plans (AMLM10)	3-40
AML230—Display/Maintain Item Trial Plans Family Selection	3-41
AML231—Display/Maintain Item Trial Plans Item Selection	3-43
AML232—Display/Maintain Item Trial Plans	3-45
Option 6. Replace Family Base Plans (AMLM10)	3-51
AML211—Replace Family Base Plans Selection	3-52
Option 7. Replace Item Production Plans (AMLM10)	3-54
AML240—Replace Item Production Plans Family Selection	3-55
Option 8. Family Plan Inquiries (AMLM10)	3-57
AML280—Family Plan Inquiries Selection	3-58
AML281—Base Plan Inquiry	3-61
AML282—Base Plan Inquiry Production Plan	3-65
AML283—Base Plan Inquiry Demand Plan	3-69
AML284—Base Plan Inquiry Inventory Plan	3-73
AML285—Operating Production Targets vs. Aggregated Plans	3-77
Option 9. Family Operating Plan Report (AMLM10)	3-80
AML261—Family Operating Plan Report Options	3-81
Option 10. Display and Maintain Production Families (AMLM10)	3-83
AML360—Display/Maintain Production Families Selection	3-84
AML361—Display/Maintain Production Families	3-86

Chapter 4. Master Schedule Planning	4-1
Option 1. Generate Master Schedules (AMLM20)	4-4
AMV3HH—Generate Master Schedules	4-5
AML410—Generate Master Schedules Planning Run Options	4-7
AML411—Generate Master Schedules Planning Run Status	4-11
AML413—Generate Master Schedules Planning Run Submit	4-13
Option 2. Display and Maintain Master Schedule (AMLM20)	4-14
AML450—Display/Maintain Master Schedule Planner/Family Selection	4-15
AML45P—Display/Maintain Master Schedule Planner Selection	4-17
AML45F—Display/Maintain Master Schedule Family Selection	4-19
AML451—Display/Maintain Master Schedule—Item Selection	4-21
AML452—Display/Maintain Master Schedule—Production Plan	4-23
AML452—Display/Maintain Master Schedule—Production Plan—Schedule Controlled Item	4-35
AML453—Display/Maintain Master Schedule	4-37
AML454—Blended Demand	4-42
Option 3. Test Master Schedule Resources (AMLM20)	4-46
AMV3HQ—Test Master Schedule Resources	4-47
AML180—Test Master Schedule Resources	4-49
Option 4. Display Resource Requirements (AMLM20)	4-50
AML531—Resource Requirements Selection	4-51
AML532—Resource Requirements Analysis	4-53
AML533—Resource Requirements Detail	4-56
Option 5. Master Schedule Planning Report (AMLM20)	4-58
AMV3HK—Master Schedule Planning Report	4-59
AML460—Master Schedule Planning Report Options	4-61
Option 6. Available to Promise (AMLM20)	4-63
AML490—Available to Promise Item Selection	4-64
AMVATP03—Display Available to Promise	4-66
AMVATP05—Display Available to Promise	4-69
Option 7. Item Requirements Inquiry (AMLM20)	4-71
AMM510—Item Requirements Inquiry—Select a planner's items	4-73
AMM511—Item Requirements Inquiry—Item overview display	4-76
AMM512—Item Requirements Inquiry—Peg To	4-82
AMM516—Item Requirements Inquiry—Select a planner's items	4-85
AMM171—Item Detail Information—Lead time factors	4-87
AMM172—Item Detail Information—Order/Schedule sizing factors	4-89
AMM173—Item Detail Information—Inventory status summary	4-92
AMM174—Item Detail Information—Item characteristics	4-94
AMM175—Item Detail Information—Requirements management factors	4-98
AMM176—Item Detail Information—Master scheduling factors	4-102
Chapter 5. Resource Profile Management	5-1
Option 1. Maintain Resource Master File (AMLM30)	5-3
AML591—Resource Master File Maintenance (Select)	5-4
AML592—Resource Master File Maintenance (Add)	5-6
AML593—Resource Master File Maintenance (Change)	5-8
AML594—Resource Master File Maintenance (Delete)	5-10
AML595—Resource Master File Maintenance (Status)	5-12
Option 2. Resource Master File List (AMLM30)	5-14
AMV3HJ—Resource Master File List	5-15
Option 3. Generate Resource Profiles (AMLM30)	5-17
AMV3HI—Generate Resource Profiles	5-18
AML501—Generate Resource Profiles Selection	5-20

AML502—Generate Resource Profiles Family Selection	5-24
AML503—Generate Resource Profiles Item Selection	5-27
AML508—Resource Profile Generation Submit	5-30
Option 4. Display and Maintain Resource Profiles	5-31
AML511—Display/Maintain Resource Profiles Selection	5-32
AML512—Display/Maintain Resource Profiles	5-34
Option 5. Item Resource Report (AMLM30)	5-40
AMV3HM—Item Resource Report Options	5-41
AMV3A1—Item Resource Report Options	5-43
Chapter 6. Available to Promise	6-1
Option 4. Available to Promise (AMLM00)	6-2
Chapter 7. Change/Display Horizon Dates	7-1
Option 5. Change/Display Horizon Dates (AMLM00)	7-1
AMV36F—Change/Display Horizon Dates	7-2
AML601—Change/Display Horizon Dates	7-3
Chapter 8. Report descriptions	8-1
Aggregation Error List (AML340)	8-3
Family Operating Plan Report (AML271)	8-4
Item Resource Report (AML321)	8-8
Master Schedule Open Order Maintenance List (AML455)	8-10
Master Schedule Planning Report (AML471)	8-12
Planning Run Status Report (AML480)	8-23
Replace Family Base Plans Error List (AML221)	8-25
Replace Item Production Plans Error List (AML250)	8-26
Resource Master File List (AML581)	8-28
Resource Master File Maintenance Edit List (AML599)	8-29
Resource Profile Exception Report (AML559)	8-30
Chapter 9. Forms	9-1
Resource Master File Maintenance form (MS-01)	9-2
Appendix A. Controlling and monitoring MPSP	A-1
Maintain your files carefully	A-2
Keep your MAPICS XA master files usable and complete	A-2
Keep the information used by MPSP up to date	A-3
Coordinate the processing dates used by MPSP activities	A-4
Monitor the operation and effects of MPSP regularly	A-5
Error lists and error messages	A-5
Special reports	A-5
Lists of essential dates	A-5
Inquiry displays	A-6
Other information to monitor	A-6
Appendix B. Data entry in MPSP	B-1
Fields MPSP uses to support MPSP activities	B-1
Item Plan file: ITMPLN	B-1
Appendix C. Creating and using the Demand Interface file	C-1
Description of the Demand Interface file	C-1
Demand Interface file layout	C-2
How MPSP uses the Demand Interface file	C-4
How Forecasting (FCST) uses the Demand Interface file	C-5
The production planning arrays (YR1DM and YR2DM)	C-5
Planning Information and Calendar date records	C-6
Demand File Date (FDPD)	C-6

YR1DM and YR2DM array dates	C-7
WKYDM (weekly demand array) dates	C-7
Converting forecasts to weekly forecasts within the first year	C-7
Conversion for 12 or 13 periods per year	C-8
Conversion for monthly periods	C-8
Changing dates in the Weekly Demand array (WKYDM)	C-9
Customer backlog in the Demand Interface file	C-10
Customer backlog	C-10
Option backlog	C-10
Creating the Demand Interface file	C-11
Creating the file with FCST installed and interfacing	C-11
Creating the file without FCST installed and interfacing	C-11
Loading the Demand Interface file	C-12
Loading forecasts	C-12
Loading customer backlog	C-12
Updating the Demand Interface file	C-13
Appendix D. Sequenced tasks for installing and using	D-1
Preinstallation activities	D-2
General preinstallation activities	D-2
Resource planning preinstallation activities	D-2
Production planning preinstallation activities	D-3
Master schedule planning preinstallation activities	D-3
Concluding preinstallation activities	D-3
Appendix E. Security areas	E-1
Glossary	GL-1
Index	IN-1

Contents	Index	Exit
-----------------	--------------	-------------

Chapter 1. Introducing Master Production Schedule Planning

This chapter contains general information about Master Production Schedule Planning (MPSP):

- What Master Production Schedule Planning does 1-2
- MPSP and the business processes 1-3
- Major functions 1-10
- How the information flows within Master Production Schedule Planning 1-12
- How MPSP works with other applications 1-15
- How MPSP works with MRP 1-18
- How MPSP works with EPDM 1-19
- How the application is designed 1-22
- Major reports 1-30
- Inquiries 1-30
- Master file queries and searches 1-31
- Using eWorkPlace with MAPICS XA documentation 1-31

Some concepts and features that are common to most of the MAPICS XA applications are discussed in two other books: *Getting Started with MAPICS XA* and *Planning and Installing MAPICS XA*.

- Menus and displays
- Group Job support
- Master file searches
- Audits and controls
- Security.

What Master Production Schedule Planning does

Master Production Schedule Planning (MPSP) is a powerful business tool for Computer Integrated Manufacturing (CIM), Manufacturing Resource Planning (MRP II), and Just-In-Time (JIT) companies. MPSP simplifies the conceptual and operational link between a high-level business plan determined by management and the manufacturing activities that support the plan.

The MPSP application provides interrelated functions in the areas of production planning, master schedule planning, resource planning, and available-to-promise. These functions complement those provided by your use of Material Requirements Planning (MRP). Effective and consistent use of these functions helps maintain a smooth product flow through your company and brings you closer to achieving your CIM, MRP II, and JIT objectives.

With MPSP, you can:

- Develop and implement manufacturing production plans, by planning warehouse, through the use of product family concepts. These concepts significantly enhance your manufacturing organization's ability to determine and carry out an achievable and challenging detailed master schedule at the item level, within user-defined resource constraints.
- Measure, by planning warehouse, actual performance and recently projected performance against the manufacturing plan. Performance measurement devices, such as the family base plan, alert you to situations where you need to revise operational plans or practices because of significant changes in the business environment or operations that are not running at optimal levels.
- Set long-term production plans, by planning warehouse, that support the objectives of upper-level management for inventory, sales, customer service, and resource use
- Generate and adjust master production schedules, by planning warehouse, based on demand from a variety of sources
- Identify the critical resources and resource quantities, by planning warehouse, that you need to meet your long-range production plans or your master production schedules.

MPSP requires three MAPICS XA applications: Material Requirements Planning (MRP), Product Data Management (PDM) or Enterprise Product Data Management (EPDM), and Inventory Management (IM). If EPDM is activated, MPSP uses EPDM files instead of PDM files. If Customer Order Management (COM) is installed and interfacing, MPSP can use COM's customer order information to generate long-range production plans, generate master production schedules, and provide online available to promise projections. If Forecasting (FCST) is installed and interfacing, MPSP can also use sales forecasts to generate production plans or master schedules. If Electronic Commerce (EC) is installed, MPSP also can use expected customer orders in production planning and master scheduling. If InterSite Logistics (ISL/MISL) is installed, MPSP can use planned and open intersite orders as demand from other planning warehouses.

MPSP and the business processes

MPSP plays a significant role in the overall business plan process and has a major impact on the plans of the following areas of your organization as they focus on achieving their business plan objectives:

- Marketing management: Facilitates manufacturing's ability to give marketing the required products on time and in sufficient quantity. This permits marketing to meet their sales revenue goals and satisfy the customer.
- Materials management: Helps reduce and maintain low component, work in process (WIP), and finished goods inventories, and helps meet inventory level objectives.
- Production management: Aids in setting stable production rates and in maintaining the smooth flow of product within capacity load objectives.
- Financial management: Facilitates keeping operating costs and resource investments at the levels necessary to maintain the profit margins.

MPSP provides a regular flow of information to company management through the use of online displays and printed reports that allow you to inquire about the status of planned and actual business operations and to make the necessary changes. Continuous monitoring of business conditions helps your company focus on the critical success factors that keep it ahead of competition.

The following is an overview of the role MPSP has in three of your most important business processes. These processes are:

- Yearly and semi-annual business plan cycles
- Monthly performance measurement and operating plan revision cycle
- Weekly/daily master production scheduling cycle.

Yearly and semi-annual business plan cycle

Most companies go through a business plan cycle on an annual or semi-annual basis. The business plan is the highest level plan which links the plans of all organizations, such as manufacturing, marketing, finance, and development. The business plan consists of projected income statements, balance sheets, return-on-investment statistics, and resource plans.

Your manufacturing organization can be linked to the business plan with the function and information provided by MPSP. MPSP allows you to develop a realistic business plan within manufacturing critical resource constraints. MPSP allows you to track performance to plan, which consequently allows you to alert other organizations as to current and projected conditions.

Figure 1-1 and the discussion following it describe how MPSP works with the business plan.

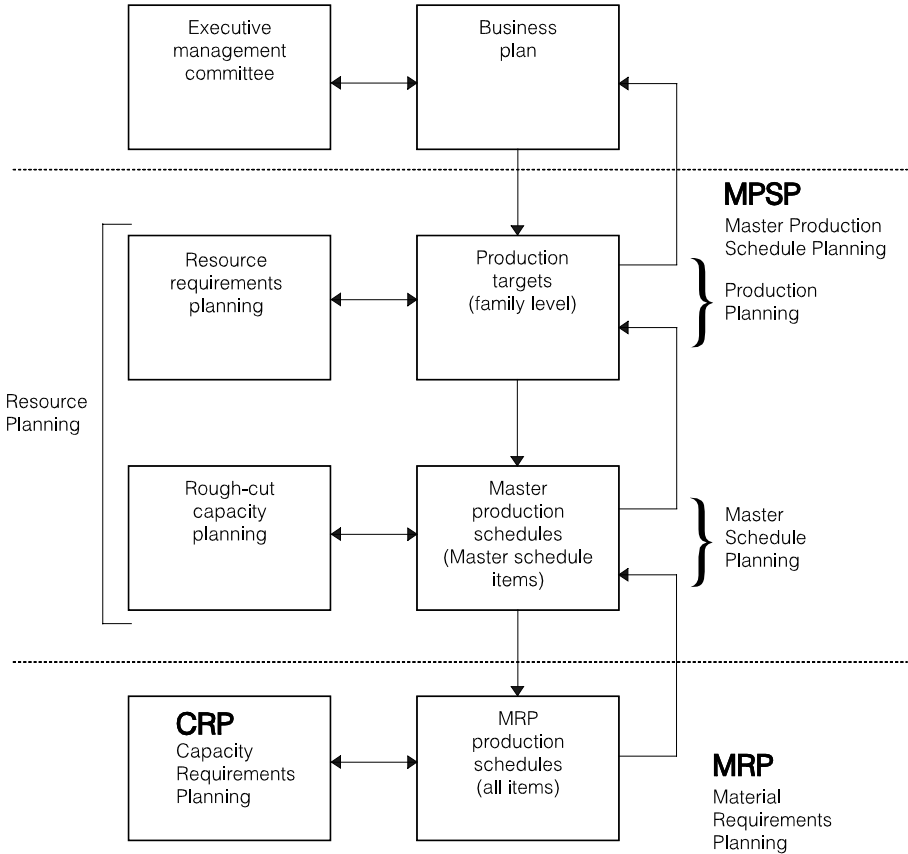

Figure 1-1. How MPSP works with the business plan

A typical manufacturer uses an executive management committee, consisting of representatives from the major organizations in the company, to develop and update the business plan once or twice a year. In the case of an extreme change in the business environment, the plan can be redone more than twice a year. The purpose of the business plan is to set objectives-by-year for the company over the next three to five years to keep ahead of the competition and provide satisfactory return-on-investment (ROI).

MPSP's product family concept allows you to group end items that share critical resources. Grouping end items into product families simplifies the business plan processes of setting overall company objectives, objectives of individual business organizations in the company, as well as yearly manufacturing production targets. For example, 200 end items may be grouped into 10 product families with 20 items per family. So you are now planning for 20 items instead of 200, and your control of the business planning processes is increased considerably.

The sales revenue-per-year objectives of the business plan are determined for product families. To meet the sales objectives, you develop a product family unit-per-year ship schedule. Then you set product family year-end inventory levels, and use those levels and the family beginning inventory to calculate family net requirements.

You create a family build schedule to meet the family net requirements. The business plan family build schedule is the equivalent of the MPSP family production targets that are a part of MPSP's production planning function.

Note: MPSP aggregated blended demand is important in determining the family unit ship forecast in the business plan cycle. The executive management committee may modify the forecast if demand for the company's products changes. If modifications are necessary, you can use the forecast override ability of the Forecasting application, if installed and interfacing, to adjust the forecast manually. After you perform some planning activities, you can modify aggregated blended demand. Effective use of the demand interface file by non-MAPICS XA applications can also provide the modified demand statement.

The MPSP resource requirements planning function (constraint testing of family level critical resource) can be used during the business plan cycle to test whether family production targets developed during MPSP's production planning can be met. The most recent aggregated blended demand can serve as a reasonability test or starting point for development of the business plan family ship schedule.

If family production targets cannot be met within current resource constraints, you must change the targets in the business plan or make an additional capital investment to support business plan volumes. A change in family production targets impacts other areas, in addition to manufacturing, such as sales revenue, capital expenditure, staffing, cash flow, financing plans, and ROI objectives.

When you rework the family production targets to bring them to achievable levels, you then save them as the family base plan. The family base plan also contains aggregated demand and aggregated inventory projections. Family base plan information is one of the monthly performance measurement tools used for the next six to twelve months.

Family production targets are revised using the family operating plan, a "working" version of the family base plan. Item trial plans distribute family production targets at the item level.

Activities involving the family operating plan, resource requirements plans, the family base plan, and item trial plans eventually yield item production plans that meet family production targets.

Master schedule planning uses item production plans or other sources of independent demand (as well as dependent demand) to develop a master production schedule of open, planned, and firm planned orders.

Item-level testing of the master production schedule is called rough-cut capacity planning. These orders can be tested against the critical resource constraints defined and generated with the resource profile management function.

If, after testing the master schedule, you find that it cannot be met, you need to revise some or all of the following:

- Master schedule with firm planned orders
- Item trial plans, and replace the item production plans with the new item trial plans
- Family production targets, and run the production planning process until you arrive at satisfactory family production targets and master schedules.

After a satisfactory master schedule is determined and is ready to be implemented, the MRP application can use MPSP's master schedule to explode component requirements and release schedules to manufacturing.

Capacity Requirements Planning (CRP) uses planned orders generated by MRP when calculating work center workloads.

Monthly performance measurement and operating plan revision cycle

Production planning performance can be measured on a monthly basis against its business plan objectives. If the organization cannot meet its objectives, you can:

- Communicate this information in a timely manner to other areas of the company that are dependent on those objectives
- Rework the family operating plan to meet those objectives.

Figure 1-2 and the discussion following it describe how production planning performance is measured monthly.

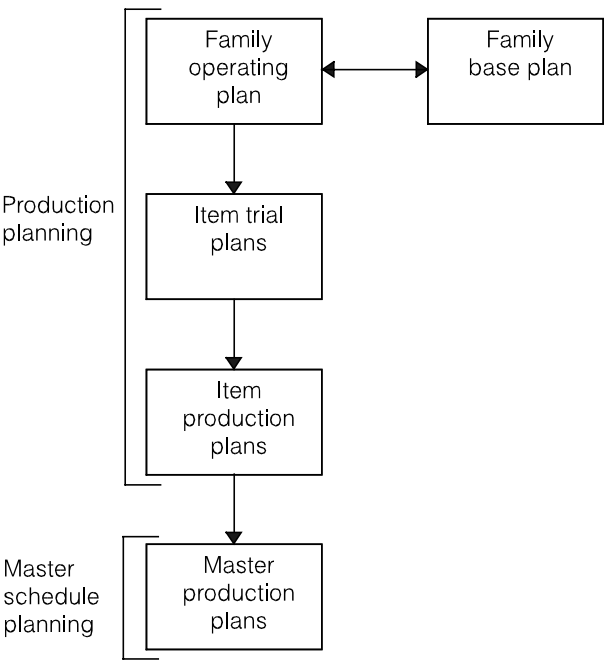

Figure 1-2. Monthly performance measurement and operating plan revision cycle

Because the family base plan remains unchanged for a significant period of time, you use the family operating plan as a dynamic working copy of the base plan. The family operating plan allows you to implement the base plan with changes because of unacceptable performance or unanticipated conditions that impact demand and schedules. The family operating plan may be reworked and its numbers changed for each production planning period. In this way, you can reflect changes to production

management, keeping the unchanged family base plan for measurement purposes while it remains linked to the business plan.

Your company may go through a monthly planning interlock session where representatives from various groups such as marketing, production, and financial planning examine business conditions and revise the estimate of demand for each of the next several quarters. A change in demand usually requires the family operating plan production targets to change so that inventory does not grow too large or drop to levels where customer service would suffer.

After the family production target revision is complete, the corresponding changes must be distributed to the item level by modification of the item trial plans. The sum of the item trial plans for each family should come close to its respective family production targets.

After you have completed a satisfactory item trial plan, you can use it to replace the old item production plan. The new item production plan can be used as the source of independent demand in master schedule planning, so that changes from the production planning level can easily be implemented by manufacturing.

Most companies measure performance against the family base plan and the family operating plan on a production planning period basis and investigate the cause if variance occurs. If production does not supply enough product to meet planned aggregated demand, the variance is production's responsibility. If actual performance and recent family operating plan revisions vary significantly from the family base plan over a period of time, production-related problems may exist, or the business environment has varied significantly from what was assumed during the business plan process. Either situation can require significant changes in planned activities of other organizations, such as marketing and finance.

For example, your revised family operating plan projects significant variances from the family base plan sometime out in the planning horizon because your vendor is experiencing quality problems on a high percentage of parts, other sources of supply are not available for several months, and there are only a few days of supply of finished goods inventory. Also, production rates must be cut by 30 percent. This results in projected, and eventually, actual monthly performance measurement variances between the family production targets of the family base plan and the family operating plan.

MPSP measurements highlight the significance of the projected variances. You can quickly pass this information to the marketing organization so it can take the appropriate action relating to sales and customer orders. You can inform the finance organization, so it can revise financial plans and cash flow estimates that were based on the previous plans and take appropriate financial action. Therefore, all organizations are working together, so that customer relations, profitability, and market share remain intact.

Weekly/daily master production scheduling cycle

Item production plans are replaced on a weekly or monthly basis for use as a source of independent demand in master schedule planning. Subsequently, some master schedule planning activities can occur on a daily or weekly basis.

Typically, while family production targets and the corresponding item production plans go through some modification on a monthly basis, master production schedule activities occur on a weekly basis, and others on a daily basis.

The primary objective of master schedule planning is to establish a set of open, planned, and firm planned orders that drive the flow of parts and production through the company and keep inventories at an acceptable level. This is an extremely important responsibility because it controls the flow of substantial assets. For the typical manufacturer, inventory comprises 40% of the balance sheet assets. The master schedule is also used by MRP for bill-of-material explosion and for the release of planned and firm planned orders.

Except for generation of the master schedule, which most businesses do weekly, the other master schedule planning activities that companies perform on a weekly or daily basis differ greatly.

Summary of production plans and the business cycle

The typical manufacturer uses the MPSP production plans in the following way:

- The family base plan is modified semiannually according to your business plan, and performance is measured against it on a monthly basis. It is one of your links to the high level business plan.
- The family operating plan is modified during your semiannual business plan cycle and monthly based on your “interlock” performance review and outlook revision session. It is used for performance measurements and new projections on a monthly basis.
- The item trial plan is modified monthly according to changes in the family operating plan and weekly according to changes in operating and business conditions. Subsequently, each revision can be used to replace item production plans. Between monthly family operating plan cycles, changes in demand can be passed to the master schedule planning function.
- Item production plans are replaced whenever you want the changes in the new item trial plan to be used in the master schedule generation.

The MPSP Main Menu

A menu is a display that lists the application tasks you can choose. The first menu in the application is called the Main Menu.

When you choose some options on the Main Menu, other menus, called secondary menus, appear. The Master Production Schedule Planning Main Menu has five options; three of these options lead to secondary menus that offer additional options. Two Main Menu options—4 and 5—do not have secondary menus.

After you use one or more menus to tell MPSP exactly what you want to do, you are ready to review or enter information on one or more displays. For example, to prepare master production schedules, you use from 4 to 7 displays.

```
AML000                Master Production Schedule Planning          *****
                        Main Menu

Type option or command; press Enter.

  1. Production Planning >>
  2. Master Schedule Planning >>
  3. Resource Profile Management >>
  4. Available to Promise
  5. Change/Display Horizon Dates

==> _____

F3=Exit      F4=Prompt   F9=Retrieve   F10=Actions
F11=Job status F12=Return  F22=Messages
```

Option 1. Production Planning. Use this option to set up production families, create family- and item-level production plans, test for resources needed to meet production plans, track performance against production plans over time, and print your production plans.

Option 2. Master Schedule Planning. Use this option to generate and adjust master production schedules, test for the resources needed to meet the master schedules, print master schedules, get available to promise information, or use MRP item inquiry.

Option 3. Resource Profile Management. Use this option to define critical resources, generate or adjust the resource profiles used for calculating resource needs, or print a report showing which resources your master scheduled items use most.

Option 4. Available to Promise. Use this option to select the item for which you want to see the uncommitted inventory quantities projected for each period within the available to promise horizon.

Option 5. Change/Display Horizon Dates. Use this option to review the planning dates and the number of weeks you included in the previous master schedule generation, along with the dates you used for setting up your production plans. Also, use this option to set new dates for the next master schedule generation and set a new starting date for your family-level production plans.

Major functions

Production Planning (menu AMLM10) utilizes product family techniques, within individual planning warehouses, to:

- Determine the composition of product families
- Aggregate item level information to the family level for planning and measurement
- Set family production targets in the family operating plan
- Test family production targets against family-level critical resource constraints and redo the targets, if necessary
- Develop item trial plans based on family production targets, item net demand, and held inventory levels
- Update the item production plan with the new item trial plan quantities that can be used as a source of independent demand for the master scheduling function
- Measure actual manufacturing performance against the family base plan
- Compare newly projected performance (family operating plan) against family base plan
- Perform "what-if" simulations.

Master Schedule Planning (menu AMLM20) allows you to develop, within individual planning warehouses, time-phased, planned orders per order policy codes that meet the demand for master scheduled items. You can choose from the following sources of independent demand:

- Item production plans (from production planning)
- Forecasts
- Customer backlog (includes:)
 - orders from customers
 - expected orders from customers (if EC is installed)
 - orders and planned orders from other sites (if ISL/MISL is installed)
- Blended demand
- Manual orders.

Master Schedule Planning also allows you to:

- Test open, planned, and firm planned orders against item-level critical resource constraints
- Utilize demand time fences to determine when to consider forecasts
- Review generated order exception codes and recommendations.

MPSP's planned orders and firm planned orders serve as a source of input for MRP's generation run.

Resource Profile Management (menu AMLM30) enables you to define, within individual planning warehouses, your critical resource constraints, and generate and maintain resource profiles (a bill of resources). The profiles are used to test whether family production targets and the item master production schedule by planning period are achievable. The resource profiles can be automatically or manually created.

The two kinds of resource planning are:

- Resource requirements planning that involves the family level resource profile maintenance and testing in relation to the family production targets shown on display AML202.
- Rough-cut capacity planning involves item-level resource profile maintenance and testing in relation to master production schedules shown on displays AML452 and AML453.

Note: The resource testing of family production targets is done from the Production Planning menu (AMLM10). The resource testing of master schedules is done from the Master Schedule Planning menu (AMLM20). The maintenance of the resource profile used in testing is done from the Resource Profile Management menu (AMLM30).

- Available-to-Promise (A-T-P) information is available from menus AMLM00 and AMLM20. It allows you to see when the product will be available for the customer.

How the information flows within Master Production Schedule Planning

MPSP supports three major types of activities: production planning, master scheduling, and resource planning. Figure 1-3 summarizes the relationship of these activities.

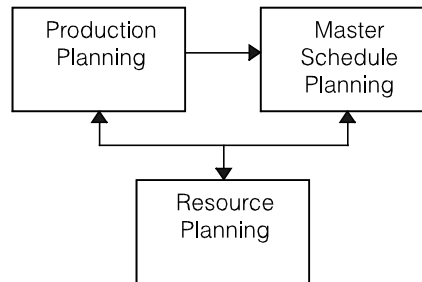

Figure 1-3. Relationship of MPSP activities

Production planning uses sales forecasts, customer orders, or a blend of both to generate production plans for up to three years. It creates the plans for production families, groups of items that use similar manufacturing resources. From the family-level plans you create item-level production plans that provide demand for the master production schedules.

Master schedule planning uses demand from item production plans, customer orders, forecasts, a blend of forecasts and customer orders, intersite orders, or manually entered firm-planned orders to generate master production schedules for intermediate-range planning. You set the beginning period and the length of the planning horizon. MRP uses the master schedules to generate orders for the components needed to meet the master schedules.

Resource planning lets you evaluate (test) the resource needs that your production plans or master schedules create. After you define the resources that you consider critical, you can calculate the quantities of those resources necessary to achieve your family-level production plans (resource requirements planning). You can also calculate the quantities necessary to meet your combined master schedules (rough-cut capacity planning).

The three activities are interrelated. The production plans you set at the family level and item level affect your master schedules; production limits at the master schedule level may cause you to change your production plans. Resource testing may show that your first plans are unrealistic and must be adjusted. MPSP lets you make changes to your schedules and see the results before MRP plans orders for the components and releases the orders.

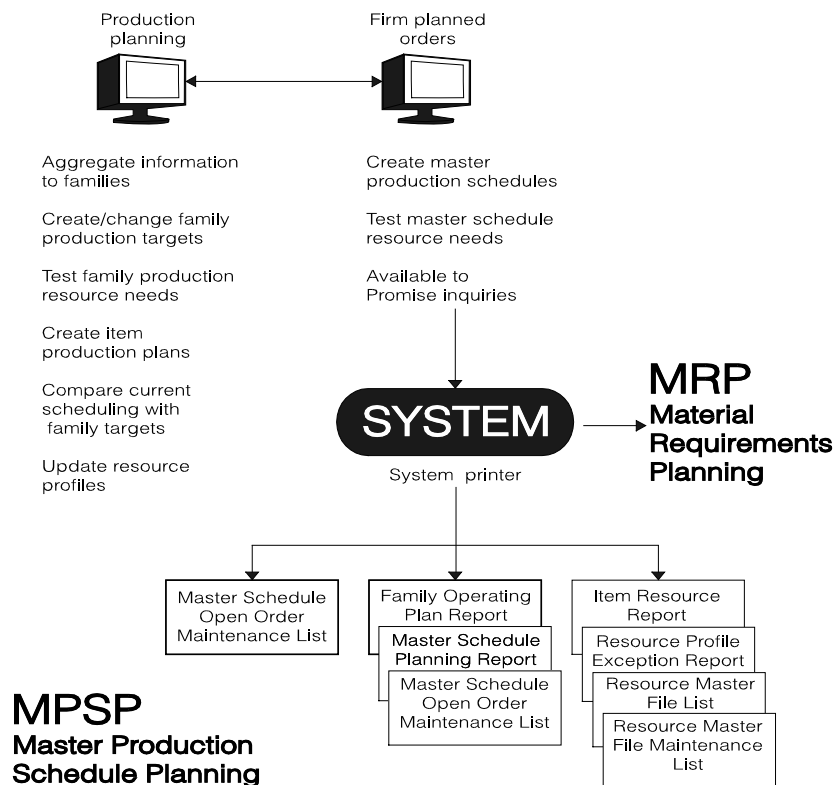

Figure 1-4. Flow of information within MPSP

As the figure suggests, you can complete all phases of MPSP Planning from a work station.

Master scheduling can start from item production plans, forecasts, customer orders, expected customer orders, intersite orders, or manually entered firm planned orders. These sources of information express the demand for master scheduled items.

If you want to use item production plans as the source of demand for master scheduling, the first step is to aggregate (add) demand and inventory information about separate items into information about production families. Production families are groups of master scheduled end items, within a specific planning warehouse, that use similar production resources. You can assign items to production families or reassign them online before you aggregate your item-level information.

After you aggregate the item-level information, the next step is to create or maintain family-level production targets for each period, based on demand and desired ending inventory levels. These targets represent management's desired levels of production.

Before you use the family production plans to create item-level production plans, you may want to test the family plans for resources needed. Testing resources tells you which resources are needed to meet each family's production plan, when the resources are needed, and how much is required.

The next step is to create new item production plans by distributing family production targets among items in the family, or by adjusting existing item production plans to reflect family changes. These new item production quotas remain as “trial plans” until you confirm them for use by replacing the previous item production plan with the new trial plan schedule quantities. The new item production plan can be used as the source of demand for master production scheduling.

In future periods, you can use inquiry displays to compare family plans with current item production plans and current master production schedules. You can also compare actual production, sales, and inventory levels to planned production, sales, and inventory levels, to see whether your production schedules are meeting management’s goals.

From your item production plans or other sources of demand, you can create master production schedules. The scheduling process plans orders to meet demand for the end items and component items that you have chosen as MPSP master scheduled items. You can review and adjust the planned orders online. You can also select a Master Schedule Planning Report to be printed as a worksheet for a more permanent record of the orders and related messages.

You can test the master production schedules for resources needed. If you are still within your facility and resource limits, you can expect to produce the orders as scheduled.

After you have created and made the necessary changes to the MPSP master production schedules, the MRP application uses the master scheduled orders to plan the component orders needed to meet the master schedules. These orders can be pegged to customer orders if master scheduling codes D or E are used.

At intervals you need to update your resource profiles. A resource profile identifies which critical resources a master scheduled item or production family uses. It also calculates how much of each resource a standard lot or a standard batch of the item requires and the point in the production routing when each resource is needed. Resource profiles are the basis for resource testing and resource planning.

The Resource Profile Exception Report is printed when you generate resource profiles. It can alert you to potential problems in the lead times and lot sizes or batch sizes that you are using to plan orders, schedule production, and estimate resource needs.

At any time, you can use the Available to Promise display to get real-time information about the quantities of an item that can be committed to sales or other uses in any planning period. The information can be useful to order-entry personnel as well as to planners.

How MPSP works with other applications

MPSP uses detailed information from other MAPICS XA applications.

Required:

- Inventory Management (IM)
 - Tracks receipts against item production plans
 - Tracks sales against forecasts if COM is not installed and interfacing (SA transactions)
 - Sets off Order Maintenance Pending flag when open orders are maintained
 - Provides open order information
 - Provides inventory balance information for on-hand inventory, held inventory, safety stock, and allocations
 - Provides unit cost default for production planning and resource profile calculations.
- Material Requirements Planning (MRP)
 - Provides offsets to MPSP to establish the start of the MPS horizon and MPSP time-phased allocations
 - Updates MPSP orders with release and maintenance activity
 - Extracts master scheduled orders from MPSP on demand for use in MRP planning runs.
- Repetitive Production Management (REP)
 - Provides schedule information. See *Material Requirements Planning (MRP) User's Guide* for smoothing information.
- Product Data Management (PDM)
 - Provides product structures for master schedule planning and resource planning
 - Provides routings and work center information for resource planning
 - Provides Item Master and Production Facility file maintenance for maintaining resource numbers.

Or:

- Enterprise Product Data Management (EPDM)
 - Start date determines the item revision number and primary process to use when generating component requirements
 - Item process is stored in planned order (includes revision number, alternate bill of material identifier, routing identifier and version)
 - Uses the process specified in a firm planned order
 - During order review/maintenance, user can view and select alternate processes.

Optional:

- Forecasting (FCST)
 - Provides up to 3 years of forecasts for master scheduled items in the Demand Interface file.
Note: Forecasts go to the Demand Interface file if the item is coded as a master scheduled item; otherwise, they go to MRP's Requirements file.
 - Puts the date of the first forecast period in the Planning Information file.
 - Smooths weekly forecasts with the next period.
 - Loads forecasts to the day of the week specified in MPSP's installation questionnaire.
- Customer Order Management (COM)
 - Provides customer backlog to MPSP
 - Captures sales that consume the forecast in the current production planning period and the current master scheduling period.
- Electronic Commerce (EC)
 - Provides expected customer orders (EDI 830/DELFOR transactions transmitted from your trading partners) for use as demand in production planning and master schedule planning.
- InterSite Logistics (ISL/MISL)
 - Open intersite orders from other planning warehouses are represented as COM customer orders.
 - Planned intersite orders from other planning warehouses are used in production planning and master scheduling as demand.
- Purchasing (PUR)
 - If installed, sets off Order Maintenance Pending flag. If not installed, IM sets the flag off.
 - Provides order release function for purchase orders.
 - Provides requisition entry function.

Master Production Schedule Planning interfaces

MPSP sends information to ...

MRP Extracts master production schedules for MRP planning activities; updates maintenance changes to firm planned orders.

MPSP receives information from ...

COM Customer order backlog and option backlog for master schedule planning and available-to-promise; accumulates sales transactions and supplies customer orders to production planning and master schedule planning.

EC Expected customer orders received via EDI from trading partners are supplied to production planning and master schedule planning.

EPDM or PDM Item process and bill of material information and item characteristics.

FCST Forecast requirements to the Demand Interface file.

IM Calendar, item balance, and order status and period sales and production receipts for planning runs; lead times and planning process codes.

ISL/MISL Demand from both released and planned intersite orders against a warehouse are supplied to production planning and master schedule planning. ISL/MISL creates customer orders in COM for released/open intersite orders against a warehouse. ISL/MISL passes the demand from planned intersite orders directly from MRP in the requesting warehouse to MPSP in the supplying warehouse, where it is added to both forecasts and customer orders.

MRP Updates to planned orders for master scheduled items.

PUR Open purchase orders and requisitions.

I

How MPSP works with MRP

When you are ready to use them, the approved master production schedules from MPSP provide the input for MRP's planning activities. MPSP and MRP have both similarities and differences in their scheduling functions. The similarities are:

- Both plan orders for end items and major component items identified as master scheduled items (MSI) in MPSP, master level items (MLI) in MRP.
- Both use current demand and inventory information.
- Both release orders through MRP's order review/release cycle.

The chart below summarizes some of the differences and can assist you in determining whether you want MPSP or MRP to plan the item.

MPSP	MRP
Plans orders for master scheduled items (MSI) only	Plans orders for master level items (MLI) and component items (not master scheduled items)
Plans orders based on forecasts, customer orders, expected customer orders, blended forecasts and customer orders, production plans, intersite orders, or user-entered orders	Plans orders based on propagated requirements or user-entered requirements
Plans orders to user-defined horizon end (3-year maximum)	Plans orders to last requirement entered (5-year maximum)
Allows planning by level to any desired level	For MLI items, allows planning to level set in execution options
Performs planning run from job queue or work station	Performs planning run from job queue only
Uses demand and CMLT time fences in planning; shows time fences on displays and reports	Does not use time fences
Master production schedule generation does not affect MRP files	MLI schedule generation deletes MRP planning records
Does not plan orders inside last firm planned order or open order	Plans orders wherever un-met requirements exist
Exception codes are alphabetic; messages are generic	Exception codes are numeric; messages are specific
Retrieves schedules by item, planner, or production family	Retrieves schedules by item or planner
Adds, changes, or deletes planned orders on master schedule maintenance displays	Changes or deletes planned orders on order release/review displays
Shows order status on maintenance displays	Does not show order status on maintenance displays
Maintenance displays retrieve current scheduled receipts	MLI maintenance displays retrieve scheduled receipts as of last MLI planning run
Allows testing all schedules against resource profiles	Allows minimal resource testing against requirements
Supports high-level planning for groups of related end items (production families)	Does not support high-level planning or planning for groups of items

How MPSP works with EPDM

If EPDM is active, some changes occur in MPSP's planning run, order review, production planning, and resource planning functions.

MPSP accesses effective EPDM engineering records based on need dates. Need dates apply to planned order start dates or to which item revision master is used to print for a report heading. The item revision master record is selected based on the horizon date for which the function is effective:

- Current horizon date for master scheduling
- Current operating plan date for production planning
- Item resource effective date for resource planning

If EPDM is being used, MPSP programs will calculate adjusted quantity per, since that field is not maintained in the EPDM bill of material file.

When using EPDM files, only one site-item-revision master record can be accessed for an item when retrieving information about an order. The effective item is either the Site-Item-Revision effective for the date being processed (as in a planned order start date), or if the item must be displayed for heading information, then the effective Site-Item-Revision is based on the current effective date of the associated plan. In the event that a site-item has revisions with overlapping effective dates, the newest revision is used for planning.

Changes in Master Schedule Planning with EPDM enabled

In the planning run, the following changes are implemented:

- A planned order's start date is used to determine the effective item revision record and the primary item process for each planned order. The item process ID is stored with each planned order and indicates if an alternate bill of material is to be used when exploding the planned order to lower level component requirements. It also indicates the routing to use when the order is released.
- If yield is used for the component being planned, the adjusted quantity per of the component is calculated.

Item process information can be overridden in the order review function, if an alternate bill or routing is desired. You can display the processes available and then select the one desired.

When an item is displayed as a header record, as in Display and Maintain Master Schedules, the site-item-revision record selected is based on the MPSP current horizon date.

Changes in Production Planning with EPDM enabled

It is not necessary for MPSP to determine item process information during production planning. The only change affecting this function is that item-revision records to be used in header information are selected by EPDM based on the operating plan date.

Changes in Resource Planning with EPDM enabled

Resource generation uses EPDM's item revision master, primary item processes (bills of material, routing, and facility files) to build resource profiles. When an item is displayed as a header record, as in Display and Maintain Resource Profiles, the site-item-revision record selected is based on the resource profile's effective date.

How MPSP works with ISL/MISL

MPSP interfaces to InterSite Logistics (ISL/MISL) for planning items normally transferred between distribution and/or production warehouses. InterSite Logistics helps plan and control the transfer of items between requesting and supplying warehouses. Both the requesting and supplying warehouses must be defined as planning warehouses in MAPICS.

In MPSP and MRP for a requesting warehouse:

- The orders planned in MPSP or MRP for items identified in ISL as intersite items are passed by ISL/MISL to the supplying warehouse identified in ISL as time-phased projected demand, for use in MPSP or MRP in that warehouse, depending on which application plans the intersite item in that warehouse. Each intersite item in a warehouse can have only one identified supplying warehouse, but different items in a warehouse can have different supplying warehouses.

Following a planning run, planned and firm planned orders for items identified in ISL/MISL with either a planner default warehouse or an item default warehouse are made available to the supplying warehouse. In ISL, they are extracted by ISL when needed in MRP or MPSP in the supplying warehouse. In MISL, the requirements for the planned orders against warehouses in other environments are extracted into the InterSite Transfer Requirements file, and sent to the other environments.

- MRP order review and release functions provide the review and release of intersite orders, sent to ISL/MISL, which also passes actual demand to the supplying warehouse. The supplying warehouse can be changed or overridden in order review/approve; and you can release an intersite order for an item that is not normally an intersite item.

When an order is approved for release as an intersite order (order type = I) in order review, the intersite order number (Xnnnnnn) is assigned, and a record is added to the ISL/MISL Intersite Order file. When order release is run, a customer order is created in the supplying warehouse, using off-line files, to represent that demand. The intersite order is updated with the COM customer order number. The intersite order is a scheduled receipt to MRP until it is received at the requesting warehouse using an ISL/MISL menu option.

In MPSP for a supplying warehouse:

- The projected demand from planned intersite orders in requesting warehouses is passed by ISL/MISL to MPSP for master scheduled items in the supplying warehouse, and included in MPSP as both forecast and customer order demand. This allows you to plan intersite items regardless of how you plan the item in MPSP.

The projected demand from planned intersite orders on the supplying warehouses is extracted when customer orders are extracted and loaded as both forecast and customer order demand. This keeps the forecast and customer orders in balance, to allow blending of demand to work correctly. For example, if the forecast (of customer orders) for a period is 600; customer orders

for 675 have been received, and there are planned intersite orders for 100; MPSP would show 700 for the forecast and 775 for the backlog, and thus 775 for the blended demand.

- The actual demand from released intersite orders in requesting warehouses is passed by ISL/MISL to the supplying warehouse as COM customer orders, and thus is used as demand whenever COM orders are used in MPSP.

The actual demand from released intersite orders on the supplying warehouse, stored as customer orders, is handled in MPSP the same way other customer orders are handled. The customer order remains open until the order is shipped from the requesting warehouse using an ISL/MISL menu option.

How the application is designed

In MAPICS XA, a standard system structure supports the application and system functions. Most of the structure elements such as using menus and displays, group job support, and master file searches are discussed in *Getting Started with MAPICS XA*. The structure elements discussed here are:

- Data entry: You enter data on a display. Each piece of data, such as an order quantity or a resource number, is called a field. A group of fields make up a record, and a group of records make up a file. For example, you can enter information about a critical resource into a record of the Resource Master file.
- Files: The information entered into the system for the MPSP application is placed in master files. Other files, called work files, may hold information that was copied from or that is to be placed in a master file.
- Application tailoring: Application tailoring is the process of adapting the MPSP application to fit your business. You tailor the application during installation by answering a questionnaire. This process is described in *Planning and Installing MAPICS XA*.

Data entry and update methods

MPSP uses online updating. Online updating means that the files are updated as soon as the necessary information has been entered and edited. Most of the maintenance displays, such as Display/Maintain Family Operating Plans (AML202) or Display/Maintain Master Schedule (AML452) appear in Inquiry mode; function keys let you add, change, or delete information on the same display. The system updates the file as you complete each action.

One file, the Resource Master file, uses separate displays for adding, changing, or deleting information in the file. However, the updating occurs as you complete each transaction, not at the end of the session.

Figure 1-5 illustrates the update method. The program edits the data, such as order quantities and start dates, and immediately updates the master file.

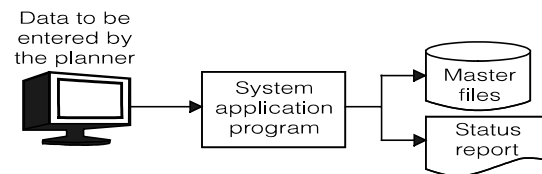

Figure 1-5. Data entry in online update mode

Concurrent use of MPSP files

MPSP allows an unlimited number of users to perform the same kind of file maintenance activity, such as adding a master scheduled order.

Files

There are three kinds of files described in this section: the System Control file, master files, and work files.

System Control file

The System Control file (SYSCTL) is the major system file for MAPICS XA. It shows relatively unchanging information used by more than one application or operation. When you install an application and enter responses to the questionnaire, the information is stored in SYSCTL. It contains the functional options you chose, the report options you chose, and any constant information you entered (such as company name). To change information in the System Control file, answer the questionnaire again or use Cross Application Support file maintenance.

Master files

MPSP uses and maintains information in a number of master files. Some are used only by MPSP; others are shared with other MAPICS XA applications.

Master files contain two kinds of information:

- Information that is relatively permanent and is used repeatedly in inquiries and reports. For example, MPSP records a critical resource in the Resource Master file for use by any task that requires that information.
- Information that changes frequently. An order in the Master Scheduled Item Orders file is an example.

Work files

MPSP creates temporary files, called work files, to hold information for processing, such as open and firm planned orders during a planning run. When the processing ends, the information in the work files is erased. Some work files are:

- Master Scheduled Item Work file
- Resource Work file
- Base Plan Work file
- Customer Order Work file.
- Master files used only by MPSP:
 - Base Plan file (BASEPL) contains the following for the base family operating plan you set for a production family:
 - Production targets
 - Blended demand
 - Starting inventory
 - Actual shipments
 - Actual receipts in the base
 - It also contains other reference information used in the family base plan.
 - Current Status file (CURSTS) contains the following for each production family:
 - Blended demand
 - Net demand
 - Total item adjustments.

The system updates this file each time you aggregate item information to the family level.

- Demand Interface file (DMDIFF) contains item forecasts used in production planning and master scheduling. It also contains customer backlog information if COM is not installed and interfacing and if you use customer backlog or blended demand for item production planning and master scheduling. See Appendix C "Creating and using the Demand Interface file" for more information about this file. Forecasting creates the file if Forecasting is installed and interfacing; you must create and load the file if you need it and Forecasting is not installed and interfacing.
- Family Production Plan file (FPPLAN) contains the production targets you enter for each period for each production family. You update this file when you maintain family operating plans.

- Item Production Plan file (IPPLAN) contains the production quantity you entered for each period for each production planned item. These quantities provide the demand for master scheduling all production planned items. The system updates this file each time you replace item production plans for one or more families.
- Item Status file (ITMSTS) contains the following for production planned items:
 - Gross and net demand information
 - Production adjustments
 - Reference information.

This information appears on the item trial plan maintenance displays. The system updates this file during aggregation.

- Master Schedule Status file (MPSSTS) contains the aggregated master scheduled orders and aggregated item production plans for all items in the family for each production family. The system updates this file during aggregation.
- Master Scheduled Item Demand file (MSIDMD) contains demand information (except for production plans) that MPSP uses to generate master production schedules. The system recreates this file each time you extract during a master schedule planning run.
- Master Scheduled Item Orders file (MSIORD) contains all firm planned and planned orders for master scheduled items. It includes such information as the following:
 - Order start date
 - Order due date
 - Order quantity
 - Exception status code.

You update this file when you maintain master production schedules. The system updates the file when you generate master production schedules in MPSP or when you release orders in MRP.

- Planner Sequence file (PLSORT) contains the information MPSP uses to retrieve item or family information in planner sequence. The system recreates this file when you generate master production schedules with extraction.
- Production Family Relationship file (PFRELF) contains information about each production family to be used to determine resource requirements such as the following:
 - Daily production rate
 - Quantity significance,
 - Composite lot size (calculated) to be
- This file also contains information about the following for each item assigned as a member of that family:
 - Demand contribution percentage (calculated)
 - Retrieval priority
 - Scheduling duration.

You update this file when you maintain production families.

Note: MPSP also maintains an alternate index to this file based on item numbers (PFREL1 file).

- Resource Master file (RSCMAS) contains information about each critical resource you define for your business. MPSP uses this information to generate resource profiles and to test for resource requirements for family operating plans and master production schedules. You update this file when you do Resource Master file maintenance.
 - Resource Profile file (RSCPRF) contains the resource profiles you generate or create for use in resource testing. It includes quantity and offset information about each use of a critical resource in producing a standard lot or batch of a master scheduled item or production family. The system updates this file when you generate resource profiles. You update this file when you maintain resource profiles.
 - Resource Test file (RSCTST) contains the results of projecting the resources needed to complete your family operating plans. It includes information about the quantity and value of each use of a critical resource to meet a production target. The system replaces this file each time you test family operating plan resources.
 - Resource Test1 file (RSTST1) contains the results of projecting the resources needed to complete your master production schedules. It includes information about the quantity and value of each use of a critical resource to meet a master scheduled order. The system replaces this file each time you test master production schedule resources.
- Master files MPSP shares with other MAPICS XA applications:
 - Calendar Header file (CALHDR) contains the work days for a five-year calendar you define using Work With Calendars in IM or MRP. IM builds this file from the date and year information you enter. MPSP shares this file with MRP, IM, and FCST (if installed and interfacing).
 - Customer Order Management files contain customer order backlog and option backlog information. Records are shared with Capacity Requirements Planning (CRP), IM, MRP, and COM (if installed and interfacing).
 - The Expected Customer Orders header (EXPCOH) and detail (EXPCOD) files contain records for expected customer orders received as EDI 830/ DELFOR transactions from trading partners using the Electronic Commerce (EC) application. MPSP uses this information to load demand into production planning and master scheduling. MPSP shares this file with EC and MRP.
 - The Intersite Order file (XFRORD) contains one record for each released intersite order. MPSP gets the current status of the order from this file. MPSP shares this file with IM, ISL/MISL, and MRP.
 - The InterSite Transfer Requirements file (XFRMST) contains one record for each planned intersite order as generated by ISL/MISL. MPSP uses this information to load demand into production planning and master scheduling. MPSP shares this file with ISL/MISL and MRP.
 - Item Balance file (ITEMBL) contains one record for each unique item number per warehouse. Each record includes data for managing inventory, such as, but not limited to, the following:
 - Quantity on hand
 - Quantity on order
 - Historical usage
 - Lead time.
- ITEMBL is shared with IM, MRP, FCST (if installed and interfacing), and COM (if installed and interfacing).

- For PDM only, Item Master file (ITEMASA, ITEMASB) contains two records for each unique item number (MPSP requires both A and B records). The A-record includes information such as the following:
 - Item description
 - Item type
 - List price
 - Unit of measure
 - Standard batch quantity.

The B-record following each A-record includes the standard lot size and additional costing information used by MRP. The Item Master file is used by MRP, PDM, IM, COM (if installed and interfacing), FCST (if installed and interfacing), and other applications.

- Item Planning Information file (ITMPLN) contains one record for each Item Balance record. Each record contains planning information that relates to the item. The ITMPLN file is maintained through Item Balance (ITEMBL) maintenance.
 - Master schedule item code
 - Build code for generating a resource profile for the item
 - Price break conversion factor
 - MPS planning source code.
- Manufacturing Order Summary file (MOMAST) contains one record for all released manufacturing orders. Each record includes information such as the following:
 - Item number
 - Description
 - Quantity ordered
 - Quantity scrapped
 - Quantity completed
 - Schedule date
 - Item process information (if EPDM is activated).

It also includes fields for tracking order maintenance changes and exception codes from MPSP. MOMAST is shared with Accounts Payable (AP), Payroll (PR), and Production Control and Costing (PC&C), IM, and MRP applications.

- MRP Control Information file (MRPCTL) contains one record for each planning warehouse. Each record contains data which is selected by planning warehouse, such as planning run execution options, horizon dates, and planning run report options. These records are automatically created and deleted by the system. This file is used by MPSP and MRP.
- Open Order Material Detail file (MODATA) contains one record for each manufacturing component material detail. Each record includes information such as the following:
 - Manufacturing component item number
 - Description
 - Quantity required
 - Quantity issued
 - Required date.

It also includes fields for tracking order maintenance changes and exception codes from MPSP. MODATA is shared with MRP, IM, REP, and PCC.

- Planning Information file (PLNINF) contains one record for each planning warehouse. Each record contains information that is selected by planning warehouse, such as horizon values. These records are automatically created and deleted by the system.
- Planned Order file (PLNORD) contains one record for each released, planned, and firm planned order as generated in MRP. The information for scheduled receipts is copied from the open order files:
 - Manufacturing orders from Manufacturing Order Summary
 - Purchase orders from Purchase Order Item Detail
 - Purchase releases for blanket orders from Purchase Order Blanket Release Detail
 - Item process information (if EPDM is activated).

The system updates this file in every MRP planning run. MPSP uses firm planned and planned order information from this file in calculating available to promise projections.

- Product Structure file (PSTRUC) contains one record for each parent/component relationship in product structures. Each record includes information such as the quantity of this component required to produce one parent item, and effective from and to dates of engineering changes. This file is shared by MRP, PDM, IM, and COM (if installed and interfacing).
- Production Facility file (WRKCTR) contains one record for each work center in the shop, with information such as the following:
 - Description
 - Foreman
 - Prime load code
 - Queue times
 - Resource number if you identified the work center as a critical resource.

The record also contains current and standard rates, such as setup labor, used to calculate the value for a work center resource. MPSP shares this file with PDM and MRP.

- Purchase Order Blanket Release Detail file (POBLKT) contains one record for each open blanket release line item. Each record contains information such as the following:
 - Release number
 - Quantity for this release
 - Due date
 - Quantity received at dock
 - Quantity inspected
 - Quantity stocked.

This file is shared with PUR, if installed and interfacing.

- Purchase Order Item Detail file (POITEM) contains one record for each open purchase order line item. Each record includes information such as the following:
 - Item number
 - Description
 - Quantity ordered
 - Quantity received
 - Due date.

This file is shared with MRP and PUR.

- Purchase Order Summary file (POMAST) contains one record for each released purchase order and one record for each blanket purchase order. It also includes fields for tracking order maintenance changes and exception codes from MPSP. This file is shared with MRP, PUR, and IM.
- Requisition Header file (REQHDF) contains one record for each requisition created through Purchasing or MRP. Each record includes information such as the following:
 - Item number
 - Description
 - Quantity requisitioned
 - Due date
 - Buyer

This file is shared with MRP and PUR.

- Requirements file (REQMTS) contains the following records and is created by MRP:
 - MLI requirements (manual, held, and propagated)
 - Forecasts (manual and propagated)
 - Generated requirements
 - Customer orders (blanket and backlog)
 - Expected customer orders
 - Future allocations.

MRP copies this information from the COM Manufacturing Material Details and Expected Customer Order files during the MRP planning runs.

- Routing file (ROUTNG) contains the following:
 - Standard sequence of manufacturing operations for each item
 - Standard hours per unit for each operation
 - The time basis code for each operation
 - The move time to the next operation.

MPSP shares this file with PDM and MRP.

- Warehouse Master file (WHSMST) contains one record for each unique warehouse. Each record contains information about how the warehouse is defined such as controlled or uncontrolled, selling or non-selling, and planning or demand. This file is shared with FCST, IM, ISL/MISL, MRP, PM&C, PUR, REP, PCC, and EPDM.
- If EPDM is activated, MPSP also uses the following EPDM files. See the EPDM documentation for information on those files.
 - Item Enterprise (ITMENT)
 - Item Revision A (ITMRVA)
 - Product Structure Header (PSTHDR)
 - Product Structure Detail (PSTDTL)
 - Routing Header (RTGHDR)
 - Routing Operations (RTGOPR)
 - Item Process (ITMPRC).

Major reports

Although MPSP emphasizes online information, it also provides reports you can use as printed records, checklists, or audit trails. MPSP prints some reports by menu option so you get the reports when you want them. It prints other reports automatically at the end of specific tasks to tell you the status of related files and to identify any processing errors that occurred.

The major MPSP reports are as follows:

- Production planning:
The Family Operating Plan Report (AML271) shows the current family operating plans for one or more production families for any 12 consecutive periods.
- Master schedule planning:
The Master Schedule Planning Report (AML471) is the printed version of the master schedule maintenance displays.
- Resource planning:
 - The Item Resource Report (AML321) shows the top five critical resources used by each end item ranked in descending value.
 - The Resource Master File List (AML581) shows you all of the critical resources you have defined for your business.
 - The Resource Profile Exception Report (AML559) automatically prints when you generate resource profiles.

Inquiries

In addition to using printed reports, you can review certain information about your business on various MPSP displays. In MPSP, you can inquire about:

- Production plans:
 - Daily production quantities
 - Critical resources
 - Production levels
 - Base plans
 - Family production targets
 - Master-scheduled end items.
- Master schedules:
 - Planning run dates
 - Product structure levels
 - Manufacturing and purchase orders
 - Period sales forecasts
 - Daily customer orders
 - Period information for critical resources
 - Uncommitted inventory quantities
 - Material plans
 - Generated requirements.
- Resource plans:
 - Resource master file maintenance status
 - Family or item resource profiles.

- Horizon dates:
 - Master schedule generation planning dates
 - Production plan dates.
- Available to promise:
 - Inventory quantities and dates.

Master file queries and searches

MPSP now offers the following query or search capability:

- Master Scheduled Item search within warehouse for all input fields that require entry of an item number.
- Planner Select to allow you to select a planner number within a list of planners that are associated with a specific warehouse.
- Production Family query on input fields that require entry of production family identifier.
- Production Family Member query on input fields that require entry of family member identifier.
- Production item search within warehouse for all input fields that require entry of production plan item number.
- Warehouse search on input fields that require entry of a single warehouse identifier.

Fields offering query or search capability are identified by **[?]** in the field descriptions of the affected displays. See *Getting Started with MAPICS XA* for more information on using the searches.

Using eWorkPlace with MAPICS XA documentation

eWorkPlace (eWP) is the Microsoft®, Windows™-based graphical user interface for MAPICS XA. The eWP windows co-exist with the MAPICS XA character-based displays, called Host screens. If you are using eWP, you can view the corresponding Host screen for any eWP window, if necessary.

Note: If you have modified a Host screen, the GUI default is used. The default GUI feature can be enabled or disabled.

The user's guides and help text contain instructions that reference the host MAPICS XA screens (called panels and displays) rather than the eWP windows.

To understand how a Host screen instruction relates to an action on a eWP window, it is helpful to look for text on a window control that corresponds to the instruction. For example, **Cancel** on a button and on a File pull-down corresponds to the user guide instruction "use **F12=Cancel** to return to the previous display".

Note: For the instruction "press **Enter**", the corresponding control on an eWP window is an **OK** button.

The following table shows other examples of instructions from the documentation and the corresponding actions you take on the eWorkPlace window.

Documentation instructions	eWorkPlace actions
To change the details of a vendor, type 2 next to the vendor and press Enter .	Select a vendor, then select Change or type C from the List menu or select Change using the right mouse. Click the OK button.
To create a vendor, use F6 .	Select Create on the Functions menu or click the Create button.
Position to command. If you want to skip to a particular command, type the full or partial command.	Type the full or partial command in the position to entry field and click the Position button.
Type the information requested and press Enter .	Type values in or select values for the entry fields and click the OK button.
Type the information requested and use a function key.	Type values in or select values for the entry fields and click a button or select an action on the Functions pull-down.
Use the Item Master maintenance display to.....	Use the Item Master maintenance window to.....

For more information about eWP, see *Getting Started with eWorkPlace*.

Chapter 2. Managing Master Production Schedule Planning

This chapter describes the processes and calculations required to manage the MPSP application.

Before you begin Master Production Schedule Planning operations.....	2-1
Production planning	2-2
Master schedule planning.....	2-27
Resource planning	2-74
Available to promise (ATP)	2-108

Before you begin Master Production Schedule Planning operations

- Understand the design of MPSP and how it interfaces with other MAPICS XA applications as described in Chapter 1 of this book.
- Understand the features and calculations of MPSP so you can make better judgments about your operations. The features and calculations are described in this chapter under the headings:
 - Production planning
 - Master schedule planning
 - Resource planning
 - Available to promise.
- Determine the sequence of installation for MPSP procedures and prerequisite IM, PDM/EPDM, and MRP applications. See Appendix D "Sequenced tasks for installing and using" for a detailed list of installation and implementation tasks.
- Schedule the tasks involved in managing this application.

Some MPSP tasks require the dedicated use of MPSP's files. For example, you cannot maintain, within a planning warehouse, production families, family operating plans, or item trial plans while aggregating in that planning warehouse; you cannot do master production schedule maintenance or inquiry while generating master production schedules within that planning warehouse. Some activities, such as generating resource profiles, testing resources, or generating master production schedules, need to be scheduled because they can require a lot of processing time.

Production planning

Production planning provides the basis for developing master production schedules that meet the objectives of the management defined business plan.

The following major production planning activities are described in this section:

- Creating and maintaining production families
- Developing production plans
- Performing aggregation activities
 - Preparing to aggregate
 - When to aggregate
 - Aggregation process
 - Other aggregation calculations and actions
 - Aggregation Error List (AML340)
 - Consuming the item production plan and item blended demand (RCPLB, RCPLA, SALBF, SALAF)
 - How MPSP uses the current receipts and shipments fields (RCPLB, RCPLA, SALBF, SALAF)
- Developing family production targets
 - Evaluating aggregated family totals
 - Entering family production targets
 - Evaluating family production targets
- Testing production family resources
- Developing and adjusting the item trial plans
- Replacing item production plans
- Evaluating family production plans
 - Variances
 - Calculations for variances and variance percentages
 - Replacing the family base plan
 - Using the Family Operating Plan Report.

Creating and maintaining production families

Before you can do any family production planning, you need to group related master scheduled end items into a production family. The grouping is usually based on common use of critical resources by end items. You can use the Item Resource Report (AML321), which ranks the top five resources used by master scheduled end items, to determine the common critical resources.

The number of end items you group into a family is important. If you include too many items, then you risk creating a production family that is difficult to manage. If a family does not have enough items, you fragment your high-level planning and increase your time to set family operating plans and monitor them.

Before you assign items to a family, the production family must be identified by the following codes in the Item Planning file:

P Master schedule item code
blank MPS planning source code

Note: A production family can exist in only one planning warehouse.

Any item you assign to a production family must be a master scheduled end item and use item production plans as its demand source for master scheduling. You should use file maintenance to enter the following codes in the Item Planning file for each end item:

M Master schedule item code
P MPS planning source code

Note: An item can be assigned to different production families in different warehouses, as a family can exist in only one warehouse.

As you assign items to production families, you also need to decide what to enter for the following on display AML361.

- The priority of an item, based on its importance in the family. The priority level you assign to an item controls the items that you see first (retrieval sequence) when you review items, or the items that print first on reports. This lets you manage the items with the highest priority first. Importance is determined by volatility of demand, cost to produce or store, or impact on critical resources.
- The beginning and ending dates to schedule an item for production. The From and To dates you enter for item control when the item is included in the family's resource profile and aggregated family totals. The system also gives you a warning message if you try to increase or decrease production before the From date, or after the To date.
- The total amount you want to produce per day or the maximum amount you can produce per day for a family. The rate per day serves as guide when you develop your production targets for a family. If the amount you enter is a maximum quantity, the family production target for a period should not be greater than the rate per day multiplied by the work days in that period.
- The quantity significance code to shorten very large quantities for displays and reports. This code lets the system show and print the quantities in the spaces available for them. For example, some files can record quantities up to eleven positions long, but the display or report field is only seven positions long. The quantity significance code controls the seven positions you see.

After your production families are established, it is important to keep the information updated, since MPSP uses production family information to develop item trial plans, item production plans for use in master scheduling, and for developing resource profiles for production families. Production family composition should be reviewed before each aggregation.

To set up and maintain (add, change, or delete) production family information, choose option 10, Display and Maintain Production Families, on the Production Planning menu (AMLM10).

Developing production plans

There are four production plans that are developed for a planning warehouse.

- Family operating plan
- Family base plan
- Item trial plan
- Item production plan.

It is important to understand the production plans and their relationship to each other. Figure 2-1 and the discussion following the figure describe how production plans work.

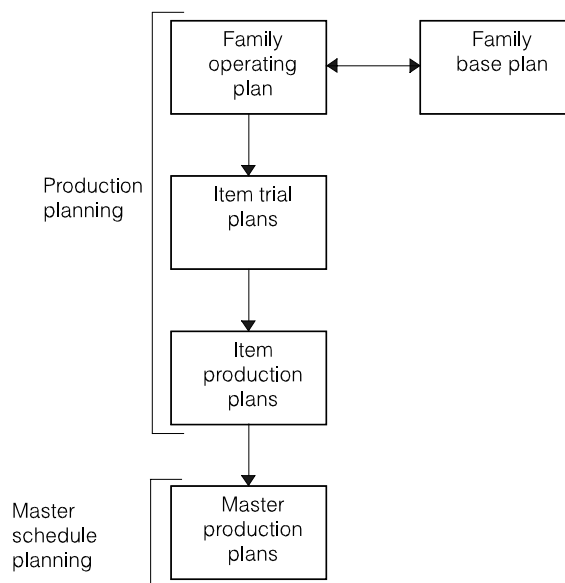

Figure 2-1. How the production plans relate to each other

You develop the family operating plan when the system accumulates planning information for production families during aggregation (described later in this section). With this information, management can set production targets for the family by production planning period considering the projected sales and inventory level they want to maintain. You can manage the information in the family operating plan in costs or units.

You create the family base plan when management approves the family operating plan (usually after you have tested the family production targets for resource requirements). If you already have a family base plan, you should replace it with the new family operating plan during a major plan cycle, usually semiannually. In most cases, the family base plan should represent the manufacturing objectives of the business plan.

After the family base plan is stored, the family operating plan becomes the “working version” of the family base plan; that is, as sales, production, and inventory conditions change, you change the family operating plan to reflect the current conditions.

The family base plan serves as a performance measurement tool. You compare the projections in the family operating plan to the family base plan to see how close the expectations of the family base plan come to the more current information in the family operating plan. You can also measure actual performance against the family base plan.

As you review and change the family operating plan, you may decide that the family production targets could be distributed differently among items in a family. If so, you can make adjustments to the item-level production quantities in the item trial plan. These adjustments may be necessary because of changing sales demand, changing inventory levels, new items being added to or deleted from families, or changes in management strategies.

Each item's trial plan consists of the following:

- The item's latest net demand by period (calculated during the aggregation process). It represents the minimum amount of inventory you must build or have on hand to satisfy sales.
- The adjustments to the item's production quantity. You can increase or decrease an item's trial plan production quantity with the adjustments you make. The adjustments build up or consume your held inventory amount.

After you finish updating the item trial plans, you can store them as item production plans for use in master production scheduling. When the new item trial plans replace the item production plans, only the total item trial plan quantity per period (net demand plus item adjustments) is stored as the item production plan.

The result is a current item production plan for use in master scheduling as a source of independent demand.

During each production planning period, the system tracks whether the amount produced for an item is equal to the quantity specified in the production plan. You can review any variance in the two values and know whether you are meeting the individual item plans within the family and therefore, meeting the family production plan.

When you develop family production targets and item trial plans, you can continue to compare the plans as well as the master production schedules to the family operating plan to ensure that all plans and schedules are meeting the production objectives for the family.

Performing aggregation activities

Aggregation is a batch process that calculates and summarizes your current inventory, demand, and production planning information at the item level into family-level totals so you can develop family operating plans and review actual vs. plan performance. The process brings together all of the inventory demands (forecast, intersite orders, expected customer orders, and customer orders); inventory replenishments (scheduled receipts, planned and firm planned orders); and the current inventory status (on-hand, safety stock, and held) by period, for all items in a production family. Options controlling whether the aggregation will include the on-hand, held inventory, and/or safety stock can be set by production family or by individual items within a production family. These options can be set using option 10 on menu AMLM10. The result is a summary of planning information that you can use to plan groups of items.

Preparing to aggregate

The time you spend preparing for aggregation ensures accurate results for developing your family operating plans. Before you aggregate item-level information to the family level, you should be sure that you do the following:

- Set up new production families.
- Complete any necessary changes to production families. (See “Creating and maintaining production families” on page 2-2.)
- Replace item production plans.
- Process all receipts and current sales.
- Verify that the demand information is current (if you use it).
- Enter the new operating plan date.

You can use the following as a checklist.

Replace item production plans. If you have changed item trial plans since the last time you aggregated, you should replace item production plans before you aggregate again. The aggregation process adjusts item trial plans that vary from the corresponding item production plans to maintain stable item production plans within the Cumulative Material Lead Time (CMLT). The results may remove some of the changes you made and want to keep. To save your adjustments to item trial plans, select option 7, Replace Item Production Plans, on the Production Planning menu (AMLM10) before you aggregate.

Process all receipts and current sales. Be sure that all inventory transactions (sales and receipts) that affect the on-hand balance are current. The aggregation process adjusts the on-hand balance to the beginning of the period with the sales and receipts of the current planning period. This adjusted on-hand balance is used to calculate the item net demand.

Be sure that demand information is current. Verify the following:

- Forecasts in the Demand Interface file are current. Forecasts may be considered current even if they were generated in a previous period. The factors that cause forecasts to not be current are:
 1. Adding new items to a production family and
 2. Making major changes in the forecast data used to generate an item forecast.
- Order entry is up to date if customer backlog comes from COM.
- Customer orders (including option backlog) are loaded into the Demand Interface file, if COM is not installed and interfacing.

Enter new operating plan date. Before you aggregate, choose option 5, Display/Maintain Horizon Dates, on the MPSP Main Menu (AMLM00) to type the beginning date of the period in which you are aggregating into the NEW OPERATING PLAN DATE field. The aggregation process makes the operating plan date the same as the new operating plan date you entered. When you change the operating plan date (it becomes the new operating plan date), and then aggregate, the system moves the family and item information to the next period and drops the current period from the files.

Notes:

1. You can aggregate more than one time in a period using the same operating plan date. If you do, the system recalculates net demand and stabilizes item production plans within the same period horizon. However, you should avoid multiple aggregations in general, because the total receipts and sales for the current period have not been realized and may cause intermediate changes to item net demand and consequently to item trial plans. Therefore, an aggregation using the same operating date is best performed one time per period under the guidelines listed in "When to aggregate" .
2. See "MPSP planning horizons" for information about production planning dates and setting the length of your production planning periods.

When to aggregate

You should aggregate only one time in a production planning period. The best time to aggregate is when:

- Current period customer backlog has been realized; that is, when no more orders are being taken for the current period.
- All period-to-date sales and receipts transactions have been processed.
- The forecasts in the Demand Interface File (DMDIFF) represent the current makeup of the production families.
- Item adjustments made to trial plans have been captured by taking the option to Replace Item Production Plans.
- People are available to work with the aggregated information both at the family and item levels.

Aggregation process

Aggregation begins when you select option 1, Aggregate to Production Families, on the Production Planning menu (AMLM10). The aggregation can be run for an individual planning warehouse or serially by warehouse within a range of planning warehouses.

Note: Aggregation may require considerable time. You should schedule aggregation to minimize your waiting time and to avoid delaying other batch jobs.

The system completes the following steps and calculations for each family during aggregation:

- Verifies production planning dates
- Maintains stable item production plans
- Calculates item blended demand
- Calculates item balance
- Calculates item net demand
- Aggregates item information to family level
- Prints the Aggregation Error List (AML340).

Verifies production planning dates. The aggregation process first checks all production planning dates. If any dates are in error (for example, the NEW OPERATING PLAN DATE is invalid), the system cancels aggregation. The date and its description print on the Aggregation Error List (AML340) so you know what dates to correct before you aggregate.

Maintains stable item production plans. After the production planning dates are verified, aggregation processes the Production Family Relationship (PFRELF) the items that are in each production family, and compares the item production plan for each item to the corresponding item trial plan. If there is a difference (variance), the system maintains the production adjustment in the item's trial plan to keep the production stable for that item within the Cumulative Material Lead Time (CMLT). The system also updates the corresponding family adjustments.

You should avoid making any changes to an item's production plan within the item's cumulative material lead time (CMLT). The CMLT establishes a horizon in which orders for the item may have already been released to vendors and to manufacturing for parts replenishment. Changes to the production plan within the CMLT could cause changes to these orders in the next master scheduling run. You should avoid unnecessary changes so that you do not disrupt the replenishment process. Ideally, you can use production plan inquiries to recognize proposed changes to the item production plan within the CMLT and make suitable production changes outside the CMLT to allow for changes in demand.

Changes to an item's production plan occur through changes to an item's trial plan, followed by taking option 7, Replace Item Production Plans. This option sums the item trial plan's net demand and item adjustments for each period and replaces the item production plans that are currently in effect in master schedule planning. Some of the changes that may cause a trial plan to change are:

- The balance of inventory available for netting against gross demand changes because receipts and sales do not occur as planned.
- A sales forecast changes.
- The master scheduler alters adjustments to the item trial plan to meet family production targets.

To avoid changes to item production plans within the CMLT caused by changes in demand, MPSP uses a technique to stabilize an item production plan within the item's cumulative lead time. This technique identifies a change in production quantities between the item production and item trial plan for each period and automatically makes item adjustments to keep the trial plan equal to the item production plan within the CMLT. The sum total of the adjustments during these periods is placed in the first period outside the CMLT to offset the adjustments placed in the preceding period.

In this way, if the automatic period adjustments are negative overall (due to increases in demand), the quantity placed outside the CMLT will be positive to indicate that more of the item must be built to satisfy the increased demand. Of course, this may only be reasonable if enough held inventory exists to satisfy the additional demand in the earlier periods. Automatic adjustments affect the item's held inventory. After adjustments are applied to the projected held inventory, if the held inventory remains positive, the increased demand can be satisfied from the held inventory and can be replenished at a later time (outside the CMLT); if the held inventory becomes negative, a warning is printed on the Aggregation Error List to bring this condition to your attention. An example of this situation follows.

The production plan is in perfect balance. The variance between the item production plan (that is serving as the independent source of demand in master scheduling) and the item trial plan (the newest statement of item demand) is zero for all periods shown under PROD PLAN BLD +/- column. The family production targets are being met for this family since the FAMILY BLD +/- columns are all 0.

Period Date	Item Prod Plan	Prod Plan Bld +/-	Item Trial Plan			Family Bld +/-	Held Inventory
			Net demand	Adjustment	Ref		
01/**	80	0	80	0		0	0
02/**	80	0	80	0		0	0
03/**	80	0	80	0	CM	0	0
04/**	80	0	80	0		0	0

The master scheduler receives a new forecast that causes the demand in period 02/** to increase. The next aggregation results in the following new item trial plan (assuming that nothing else changes):

Period Date	Item Prod Plan	Prod Plan Bld +/-	Item Trial Plan			Family Bld +/-	Held Inventory
			Net demand	Adjustment	Ref		
01/**	80	0	80	0		0	0
02/**	80	0	90	10-		0	10-
03/**	80	0	80	0	CM	0	10-
04/**	80	10	80	0		10	0

The net demand increased in period 02/** from 80 to 90. This change normally causes the item trial plan and ultimately the item production plan to increase (when the option to replace item trial plans is taken). However, the system detects that the change is within the CMLT and takes the following corrective action:

1. Creates a -10 adjustment in period 02/** to reduce the trial plan from 90 to 80 to keep the item trial plan equal to the item production plan used in master scheduling.

2. Reduces the held inventory for that period by 10 units because of the -10 adjustment. Since held inventory in this period was zero, held inventory reduces to -10, and a warning prints for this item on the Aggregation Error List. If held inventory in excess of 10 units were available, then no problem would exist because the inventory would be sufficient to meet the increased demand.
3. Places the sum of the adjustments for all periods within the CMLT in the first period outside the CMLT period and shows a negative sign if appropriate. In the example, the item trial plan calls for building 10 more units in period 04/** to replenish the unexpected reduction in held inventory occurring in period 02/**. The following are possible responses:
 - Because the held inventory is negative, the master scheduler must decide whether the production plan can be increased within the CMLT. If production cannot be increased, the increased demand might still be satisfied by the item's safety stock, which could be resupplied in the first period outside the CMLT.

If the held inventory were positive, no action would be necessary, although some attention might be given to the fact that there is now a variance of 10 units in the family production target for that period.
 - The sum of the item trial plans within this family for period 04/** is now higher than what the family production targets call for. Depending on the flexibility of the master scheduler, various solutions may exist:
 - Management can alter the family production targets, if a 10-unit deviation is significant.
 - The master scheduler can leave the variance as is, if it is not significant.
 - The master scheduler can spread the variance into other periods using adjustments.
4. This adjustment of 10 units in period 04/** causes the item trial plan to be 10 units higher than item production plan. Since it is outside the CMLT, this difference should not be a problem unless there is some kind of resource constraint.

In the example, if the only forecast change had been 70 in period 03/**, a similar situation would have existed after aggregation, except that the signs would have been reversed on the 10-unit variances, starting in period 3. In this situation, demand would have been reduced with the CMLT, and held inventory would have increased. The system would suggest a reduction in the item production plan in the first period outside CMLT to use the unexpected buildup of held inventory.

Because of the effects of reconciling the item trial plan to the item production plan with the CMLT, you should follow any changes you make to the item trial plan with the option to replace a family's item production plans before doing another aggregation. By taking this option, changes that the scheduler wants to make are accepted and reflected in the item production plans. Otherwise, aggregation will recognize a change in plans and attempt to stabilize the plan by shifting scheduler adjustments into undesired periods.

Calculates item blended demand. The system accumulates each item's demand (forecast and backlog) by period within a three-year planning horizon. If COM is installed and interfacing, the system adds the sales since the beginning of the current period to the backlog for the current period. If COM is not installed and interfacing, IM updates the sales information through sales analysis transactions. If EC is installed, the system nets expected customer orders against customer orders to prevent double counting. If ISL/MISL is installed, open intersite orders for

supplying this warehouse are represented as customer orders in COM. If ISL/MISL is installed, planned interside orders also are included as demand. The blended demand for each item is forecast or customer orders/expected customer orders/planned intersite orders, whichever is greater in a period.

Calculates item balance. To determine the item balance available for calculating item net demand, the system retrieves the on-hand and safety stock for each item from the Item Balance (ITEMBL) file and the held inventory for each item from Item Status (ITMSTS) file. Then the system adjusts the on-hand to the beginning of the period with the sales and receipts of the current planning period, and subtracts the item's safety stock and held inventory from the adjusted on-hand. The result equals the item balance used to calculate the item net demand.

Calculates item net demand. This process determines the item net demand for the current period using the item balance calculation discussed above:

$$\text{Item balance} = \text{Adjusted On Hand (OH)} - \text{Safety Stock (SS)} - \text{Held Inventory (HLD)}$$

Note: You can specify, for a production family or for individual items in the family, if you want any of the above fields excluded in the calculation of the item balance. See "Option 10. Display and Maintain Production Families (AMLM10)" on page 3-83.

$$\text{Item Net Demand (per period)} = \text{Item Balance} - \text{Blended Demand}$$

The system subtracts each period's blended demand (forecast or customer orders/expected customer orders for the item, whichever is greater) from the item balance, until the item balance is consumed. When the balance is consumed, the item net demand is equal to the item's blended demand for the period.

Note: The application expects you to aggregate in the current period, and to aggregate one time per production planning period. If you aggregate with an operating plan date in a production planning period earlier than the current period, accumulated sales and receipts data may be inaccurate causing "Calculated Item Balance" and "Item Net Demand" to be incorrect. For more information, see Chapter 7 "Change/Display Horizon Dates" on entering a new operating plan date.

The following is an example of item net demand calculation.

Period	Item balance	Blended	Net demand
1	35	10	0
2	25	5	0
3	20	10	0
4	10	5	0
5	5	10	5
6	0	10	10
7	0	10	10

Note: Item balance=OH-SS-HLD

For period 1: Item balance = 95 (OH) - 50 (SS) - 10 (HLD) = 35

Table 2-1. Example of item net demand calculation

The system uses the item net demand to calculate the item trial plan. The item trial plan is equal to item net demand plus adjustments.

Aggregates item information to the family level. The system aggregates (summarizes) the following information from the item level to the family level:

- Item blended demand.
- Item net demand.
- Item trial plans.
- Beginning on-hand, held, and safety stock.
- Item production plans.
- Master production schedules (that is, open, planned, and firm planned orders).
- Actual sales (SALBF) and actual receipts (RCPLB) from previous production planning period. The actual sales and receipts are used to update the Base Plan (BASEPL) file so you can track projected family base plan sales and production against actual sales and production. The fields are:
 - RCPLB—Receipts into inventory that occur before next production planning period date
 - SALBF—Sales (shipments) from inventory that occur before next production planning period date.

Note: See “Consuming the item production plan and item blended demand (RCPLB, RCPLA, SALBF, SALAF)” for more information.

Other aggregation calculations and actions

Besides the major calculations described above, the aggregation process completes the following:

- Retrieves the production targets for each family from the Family Production Plan file. The targets are moved forward to the current production period.
- Retrieves the item trial plan adjustments to each item from the Item Status file. The adjustments are moved forward to the current production planning period and used to update the item held inventory.
- Accumulates order quantity for items whose MPS order date is before the date of the current production planning period. These overdue orders are subtracted from the item blended demand for the current production planning period.
- Calculates weighted cost per family item.

To get an average weighted cost, the system does the following:

- Totals the blended demand for each item in the family over the production planning horizon, and multiplies that total by the item's standard unit cost (STDUC) in the Item Balance file. If that field is zero, the system uses the unit cost default (UCDEF) in the Item Master file.
- Adds together the results of the previous calculation for all items in the family.
- Divides the result by the total blended demand for the family over the planning horizon.

The system uses this weighted average cost to convert quantities from units to costs on production planning displays and reports.

Weighted cost per family item equals:

$$\frac{\text{Sum of (Item Blnd Dmd x Cost)}}{\text{Total family blended demand over horizon}}$$

Where the calculation of weighted cost per family item is:

Item Blnd Dmd = Total blended demand over the planning horizon for each item in the family

Cost = STDUC (if available) or UCDEF (unit cost default) for each item

- Calculates each item's percent of contribution to the family.
- Compares the cumulative production targets with the cumulative family net demand to find any periods where cumulative net demand is greater than the cumulative production targets. This situation indicates that you need increased production to meet net demand for all items in the family.
- Compares the aggregated safety stock with the projected inventory for the family to determine if projected inventory falls below safety stock in a period. You can use safety stock as a guide for deciding the level of ending inventory when you make changes to the Family Operating Plan (option 2, Display/Maintain Family Operating Plans Selection from the Production Planning menu (AMLM10).

The percent of contribution equals the total demand for the item for the production planning horizon, divided by the total demand for the family for the production planning horizon.

Aggregation completes processing for all items in a family, then does the following:

- Saves family information in the Current Status (CURSTS) file.
- Saves the item information in the Item Status (ITMSTS) file.
- Saves the master production schedules in the Master Schedule Status (MPSSTS) file.
- Updates the Production Planning (PPDT) date and the Operating Plan date (OPDT) in the Planning Information file.
- Prints the Aggregation Error List (AML340).

Aggregation Error List (AML340)

The Aggregation Error List (AML340) is printed at the end of the aggregation process. The report alerts you to conditions that indicate you need to change production targets or item information. Some of the situations that cause messages to print on the error list are:

- An adjustment to an item trial plan creates a negative projected held inventory
- The system finds demand before the Scheduled From date
- Item held inventory is greater than the adjusted on-hand
- Projected inventory is less than safety stock.

You can specify whether the aggregation should include the on-hand, held inventory, and/or safety stock by production family or by individual items within a production family.

See Chapter 8 "Report descriptions" for a detailed description of the Aggregation Error List (AML340).

Consuming the item production plan and item blended demand (RCPLB, RCPLA, SALBF, SALAF)

MPSP uses four fields in the Item Balance file to record receipts (production) into inventory and shipments (sales) from inventory in the current period. During aggregation the system resets the fields to record the sales and receipts in the production planning periods. The system uses these fields for comparing actual receipts against planned production and actual sales against forecast during a planning period. The fields contain the following:

- RCPLB** Receipts into inventory that occur before the next production planning period date
- RCPLA** Receipts into inventory that occur after the next production planning period date
- SALBF** Sales (shipments) from inventory that occur before the next production planning period date
- SALAF** Sales (shipments) from inventory that occur after the next production planning period date.

IM updates RCPLA and RCPLB with planned receipts and updates SALBF and SALAF with sales transactions. If COM is installed and interfacing, the system updates the sales fields (SALBF and SALAF) when you enter invoices for items. The system updates the before fields (RCPLB and SALBF) or the after fields (RCPLA and SALAF) by comparing the receipt or sales date to the next production planning period date. Receipts or sales that occur before the next production planning period date update the before fields (RCPLB and SALBF). Receipts or sales that occur after the next production planning period date update the after fields (RCPLA and SALAF).

The following figure shows what occurs during your first aggregation:

- No activity occurred before 8/13.
- On 8/13 you complete an aggregation. The aggregation process sets SALAF and SALBF to zero (since there is no recorded activity) and sets the next production planning period date to 9/1.
- As time passes, sales that occur before 9/1 are added to SALBF (45), and sales that occur after 9/1 are added to SALAF (60).

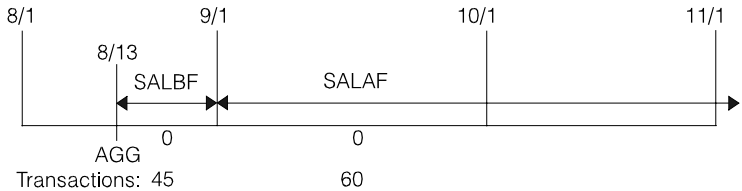

Figure 2-2. SALBF and SALAF: first aggregation

The following figure shows what occurs with the next aggregation:

- You complete an aggregation for the following month on 9/20.
- The Base Plan (BASEPL) file is updated with sales of 45 (SALBF) from the previous production planning period (August), and the previous SALBF is reset to zero.
- The previous SALAF (60) is added to the next SALBF, and the previous SALAF is reset to zero.
- The next production planning period date is set to 10/1.

The process continues through all periods and is the same for the receipts fields.

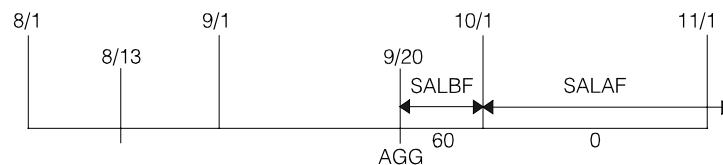

Figure 2-3. SALBF and SALAF: second aggregation

How MPSP uses the current receipts and shipments fields (RCPLB, RCPLA, SALBF, SALAF)

MPSP uses these fields similarly in production planning and master schedule planning:

Uses in production planning.

- RCPLB and SALBF update the Base Plan file with actual receipts and shipments so you can compare the family base plan to actual information on the Family Plan Inquiries displays (AML281, AML282, AML283, and AML284).
- The system uses the quantities in these fields and the stored on-hand inventory for the family to calculate the ending inventory by period.
- During aggregation, SALBF or SALAF (based on what period you are in) is added to current customer backlog for the period. The system compares the total customer backlog to the period's forecast to determine the one that is greater for the period. The result is the blended demand.
- The aggregation process uses either the before or after fields (based on what period you are in) to calculate the on-hand inventory for an item. The sales for the period are added to the item's on-hand quantity at the time of aggregation and the receipts for the period are subtracted. The result is the on-hand for the beginning of the period.

Note: You should complete an aggregation for every production planning period so that the before and after fields are updated with current information. If you do not aggregate in a period, you could have some periods with zero receipts and sales quantities, and other periods with accumulated receipts and sales quantities the next time you aggregate.

Uses in master schedule planning.

- The system uses RCPLB or RCPLA (based on what period you are in) to consume the item production plan for the current period. The RCPLB or RCPLA quantity appears in the heading of the Display/Maintain Master Schedule—Production Planned Item display (AML452) in the RECEIVED field.
- SALBF and SALAF are not used in master schedule planning since master scheduling periods begin with weekly dates. The CRPLB and CRPLA fields track sales for the weekly periods and consume weekly forecasts. For more information about the CRPLB and CRPLA fields, see “Consuming forecasts (CRPLB and CRPLA)” on page 2-72.

Developing family production targets

The family operating plan represents the latest aggregation of forecast, customer backlog, and inventory for all production families. Using the family totals from aggregation, you develop production targets for each family based on demand, production, and inventory conditions; your knowledge of the production families; and the capacity you have to produce the items in the families.

Your family operating plans should be developed periodically. The typical manufacturer revises the demand and family production targets of the family operating plans during the high-level business plan cycle (which is usually done semiannually) and during the monthly demand/supply review cycle as actuals are recorded and outlooks are revised. The family operating plans can be maintained by family within planning warehouses.

Select option 2, Display and Maintain Family Operating Plans, from the Production Planning menu (AMLM10) to develop production targets for families. The production target is the total quantity of items that management wants to produce for a family by production planning period.

Note: Before you develop family operating plans, be sure you have completed a recent aggregation. See “Preparing to aggregate” on page 2-6 for more information.

Evaluating aggregated family totals

You can review the aggregated family information for all periods in the family operating plan before you develop family production targets. This evaluation can help you decide on the production targets for your families. The following discussion points out the major areas of the family operating plan that you should consider:

Blended demand. Blended demand is forecast or customer orders/expected customer orders/interside orders, whichever is greater for a period. You develop sales forecasts using the Forecasting application. The forecasts represent management’s commitment to sell what is needed to meet the projected revenue of the business plan.

Projected inventory. Projected inventory is the quantity of items in a family that is expected in inventory at the end of a period, if you reach sales and production goals. Projected inventory is calculated differently for the first period than for remaining periods:

Projected inventory for the first period = Family On Hand + the first period Family Production Target - the first period Blended Demand

Projected inventory for remaining periods = Projected inventory from the previous period + the Family Production Target - the Blended Demand

Cumulative check. The **CUMULATIVE CHECK** field on the Display/Maintain Family Operating Plans display (AML202) shows the result of the system checking to make sure that the family's cumulative production targets are greater than or equal to the family's cumulative net demand.

A negative amount in the **CUMULATIVE CHECK** field means that production is not meeting net demand for all items in the family. This indicates that your on-hand inventory is not distributed properly among items to meet individual item net demand. Therefore, projected inventory for the family cannot be accurately calculated. For this reason, projected inventory does not appear on the Display/Maintain Family Operating Plans display (AML202) beginning with the first production planning period that has a negative cumulative check.

In the following example, items A, B, and C make up one family. In the first figure, you see the blended demand, on-hand, and net demand quantities for each item for one period:

Items	Blended demand	On hand	Net demand
A	100	0	100
B	200	0	200
C	100	500	0

Table 2-2. Cumulative check: item totals

The family totals follow for the three items for on hand (500), blended demand (400), and net demand (300). You also see the production target of 100, which is the quantity that management wants to produce for the family. The projected inventory is calculated by adding the on-hand (500), plus the production target (100), minus the blended demand (400). The result is a projected inventory of 200.

On hand = 500

Production targets	Blended demand	Projected inventory	Net demand	Cumulative check
100	400	200	300	200-

Table 2-3. Cumulative check: family totals

When you first review this example, the on-hand quantity (500) used to calculate the projected inventory for the family seems more than enough to help meet net demand. As you look at the items, however, you see that the on-hand is all for Item C. You have a total net demand of 300 for items A and B and zero on-hand to help meet that demand. The negative cumulative check quantity shows you that your production target of 100 is not enough. You need to increase production by at least 200 to meet net demand for all items (not just one item) in the family.

In the example above, if you increase the production target for the family by 200 in or before the period with the negative cumulative check, the projected inventory is 400: on-hand of 500, plus a production target of 300, minus blended demand of 400 equals 400.

Maximum target. The maximum target is the maximum or desired quantity of items in a family that can be produced in a period. Be sure that the production target for a period is not greater than the maximum target if you are using the quantity as a maximum value. The system calculates maximum target by multiplying the Production Family Daily Rate (PFCAP) in the Production Family Relationship (PFREL) file by the work days in each period.

Entering family production targets

The family production targets are entered on the Display/Maintain Family Operating Plans display (AML202). As you enter the targets, the system recalculates projected inventory and cumulative check. You can choose one or both of the following methods to develop production targets for your families:

- Enter a production target for a single period.
- Enter a desired level of ending inventory and beginning and ending period dates. The system calculates the production targets for the range of periods you specify to meet the entered ending inventory amount.

The second method is better when you first start using production planning and do not have targets established for any production families. The range of periods you specify can cover the entire production planning horizon. When the targets are calculated, you can change individual targets or specify dates for a smaller range of periods until you have acceptable targets for each period.

The system completes the following steps to calculate the family production targets for a range of production planning periods:

1. Summarizes the family blended demand for the range of periods you specified.
2. Adds the desired ending inventory to the family blended demand to determine the total demand for the range of periods you entered.
3. Calculates net demand by subtracting the projected inventory of the previous period.
4. Summarizes the work days in each period for the range you specified.
5. Calculates the average daily production for the range of periods you specified:
Average daily production equals:

$$\frac{\text{Blended demand} - \text{beginning inventory} + \text{desired ending inventory}}{\text{Total work days for range of periods specified}}$$

6. Multiplies the average daily production by the work days in each period of the range you specified.

The above steps calculate production targets based on a level-loading of production on a daily basis.

When the targets are calculated for each period you specified, the Display/Maintain Family Operating Plans display (AML202) appears with the new **PRODUCTION TARGETS**, and the **PROJECTED INVENTORY** and **CUMULATIVE CHECK** fields recalculated.

Evaluating family production targets

When you have established family production targets for the periods you specified, you can compare them to additional family information on the Family Operating Plan Detail display (AML203):

- Aggregated trial plan. This is equal to the item net demand for the family plus the adjustments for the family.
- Aggregated item net demand. The sum of the current item net demands for the family. See the detailed explanation of aggregation earlier in this section for the item net demand calculation.
- Aggregated adjustment. The sum of the current item adjustments for the family. The system updates the family adjustment in the Current Status (CURSTS) file each time you change item adjustments (see the discussion of "Developing and adjusting the item trial plans"). This aggregated adjustment field lets you compare the production target to the aggregated trial plans without an intervening aggregation.

Note: The sum of a family's item trial plans (aggregated trial plans) should be equal to or come close to the production target for the family. Any difference you see between the production target for a family and the family's aggregated trial plans represents a change in item net demand since the last aggregation (assuming that the production target and aggregated trial plans were equal immediately after the aggregation). The change possibly occurred in the forecast or in the on-hand inventory used to calculate item net demand.

Family Build +/-. As previously mentioned, the sum of a family's item trial plans should be equal to or come close to the production target for the family. The FAMILY BUILD +/- (build more or build less) field shows you the amount that the family production targets are varying from the latest aggregation of net demand and current adjustments. A positive variance indicates that you need to build more for the period to meet management's desired production targets. Any quantities that you build in excess of demand are added to held inventory to help you meet demand in those periods when demand is greater than management's production targets.

A negative variance means you need to build less. One way to build less is to meet some of the net demand by shipping from held inventory. The FAMILY BUILD ± variance on the Family Operating Plan detail display (AML202) is also shown on the Display/Maintain Item Trial Plans display (AML232) to help you maintain your item trial plans to meet family production targets.

Ideally, the amount you want to see in the FAMILY BUILD +/- field is zero. This means that the family's item trial plans added together for the period equal the production target for the period. If you developed your last family operating plan so that this was true, any variations you see in the FAMILY BUILD +/- field are due to changes in the family's net demand. A family's net demand is affected by changes in forecast, customer backlog, and production or sales that do not occur as expected.

To make the amount in the FAMILY BUILD +/- field zero, select option 5, Display and Maintain Item Trial Plans, on the Production Planning menu (AMLM10) to adjust the item trial plans for a family. See "Developing and adjusting the item trial plans" for more information.

Daily rates. If you measure your production based on quantity produced per day, you can review the production targets converted to a daily rate per period on the Daily Rates display (AML204). You can compare the values in each period to the daily rate you specified for the family using option 10, Display and Maintain Production Families, on the Production Planning menu (AMLM10).

Target rate per day. The Target Rate Per Day is the amount you must produce daily for the family so you can meet the production target for the period. The Target Rate Per Day is equal to the production target divided by the number of working days in the planning period.

Trial rate per day. You can review the aggregated trial plans converted to a Trial Rate Per Day for each period. The trial rate lets you know the total quantity of items you must produce daily for the family so you can meet the trial production plan. The trial rate is equal to the trial production plan divided by the number of working days in the planning period.

Testing production family resources

After you develop the family production targets in your family operating plans, you can test the resources needed to meet the family production targets. See "Testing production family resources" on page 2-20 for more information.

Developing and adjusting the item trial plans

When you are satisfied with your family production targets, you develop item production plans to support those targets. Item production plans are based on item trial plans, "working" versions of item production plans. You alter the item trial plans for the items in each family and then replace your item production plans with the new item trial plan quantities. The result is a new item production plan that master scheduling can use. Item production plans can serve as one source of independent demand for master scheduling.

Making adjustments to the item trial plans

The item trial plan is equal to the item net demand (calculated during aggregation) plus any item adjustments you make. An adjustment is the quantity by which you need to increase or decrease production relative to net demand for an item. Adjustments to one or more items in a family can help you meet the production target for the family.

The system stores the item adjustments in the Item Status (ITMSTS) file and updates the family adjustments in the Current Status (CURSTS) file.

The family trial plans can be maintained by family within planning warehouses.

Select option 5, Display and Maintain Item Trial Plans, on the Production Planning menu (AMLM10) to review and maintain item trial plans. After you select a family or item, you adjust the new trial plans on the Display/Maintain Item Trial Plans display (AML232).

The information on the display lets you make the following comparisons as you determine what items need production adjustments:

- The item trial plan compared against the item production plan. You can see the amount the trial plan varies from the current production plan in the **PROD PLAN BUILD +/- (Production Plan Build More or Build Less)** field. By reviewing the **PROD PLAN BUILD +/-** value in each period, you can determine how much more or less of an item you need to build to meet the item production plan currently used by master scheduling. This comparison is used to analyze the schedule churn or nervousness, which would be caused with the new item trial plan.

As you enter adjustments, the system recalculates the variance in the **PROD PLAN BUILD +/-** field. This lets you see the effects your changes to the item trial plan have on master scheduling before you approve and accept the item trial plan. The system calculates the **PROD PLAN BUILD +/-** value by subtracting the current item production plan from the item trial plan.

- The sum of the item trial plans compared against the family production target. You can see how much the sum of the item trial plans for a family vary from the family's production target in the **FAMILY BLD +/- (Family Build More or Build Less)** field. This value indicates the adjustments you need to make to the item trial plans for a period to build the production quantities set in the family operating plan. This **FAMILY BLD +/-** amount is the same **FAMILY BLD +/-** shown on the Family Operating Plan Detail display (AML203).

As you enter adjustments to bring the sum of the item trial plans closer to the family production target, the variance in the **FAMILY BLD +/-** field is recalculated. This lets you see the effects of your adjustments would have on the family operating plan if accepted. The system calculates the **FAMILY BLD +/-** value by subtracting the sum of the item trial plans for the family from the production target for the family.

When you make item adjustments, you should consider the effects your changes has on projected held inventory. If you increase production in excess of net demand, your inventory levels increase also. Your goal is to meet management's production targets (as discussed above) and control the level of projected held inventory.

- CM, PS, and PE codes

As you make adjustments to item trial plans, you should pay close attention to the two-character code in the **REF (Reference)** field on the Display/Maintain Item Trial Plans display (AML232). The codes give you the following scheduling information about an item:

- CM** The item's Cumulative Material Lead Time (CMLT) falls within this period. You should be careful when making adjustments within the CMLT, since a change could have a disruptive affect work-in-process schedules.
- PS** Production for the item begins in this period. Production should not be scheduled before this period since tooling may not be available to produce the item. Therefore, you should not specify production adjustments before this period.
- PE** Production for the item ends in this period. Production should not be scheduled after this period since the item may be phased out of production after this date, and replaced by another item. Therefore, you should not specify production adjustments after this period.

Changing current item held inventory. The current item held inventory you see in the heading of the Display/Maintain Item Trial Plans display (AML232) is the total quantity of an item's on-hand inventory set aside for future planned shipments.

The held inventory function is useful where net demand in some future period exceeds your production capacity in that period, so, to meet net demand on time, you must build ahead. This may occur for an established product, for a seasonal product, for a product where production capacity is being ramped-up, or a situation where a new product is being introduced with an extensive promotional campaign and its success is contingent on its immediate release.

Held inventory quantities are maintained in a number of ways. The HELD INV MAINT function key on this display impacts the held inventory amount relative to the current on-hand inventory. This amount is then carried through the subsequent production planning periods unless changed by a positive or negative quantity in the item trial plan adjustments field. A positive amount increases the held inventory and a negative amount decreases it from that production planning period onward until the next adjustment quantity is reached. This logic results from the fact the item trial plan is the total of the item new demand and item adjustment. So, a negative adjustment means the item trial plan for that period is less than net demand and, consequently, the uncovered net demand consumes the difference from the held inventory amount.

The adjustment quantities that you accept as satisfactory for increasing or decreasing production in a period cause the system to recalculate the projected held inventory you see in each period of the Display/Maintain Item Trial Plans display (AML232).

The system projects the amount of goods that are reserved in held inventory at the end of each period by adding each period's adjustment to the current item held inventory (shown in the heading of the display). This projected held inventory plus safety stock provides an estimate of the inventory required for each period. Due to changing conditions, such as actual shipments that are greater than or less than expected, the system's calculation for held inventory may not be accurate. If so, you can change the current held inventory to a more realistic quantity and the system recalculates the projected held inventory and net demand for each period.

The system stores the new held inventory and net demand in the Item Status (ITMSTS) file. The system adds the difference between the old values and the new values for held inventory and net demand to the **FAMILY HELD INVENTORY (FMHLD)** and **FAMILY NET DEMAND (FMNET)** fields respectively, in the **Current Status (CURSTS)** file.

Replacing item production plans

After you have adjusted the item trial plans of a family so that their sum equals or comes as close as possible to the family production target in the operating plan, you are ready to replace the current item production plans. To create or update item production plan with the new item trial plans, for a single planning warehouse or a range of planning warehouses, use option 7, Replace Item Production Plan, on the Production Planning menu (AMLM10).

You can replace item production plans with the item trial plans you developed for one or all production families.

If you select a range of planning warehouses, all production plans for all planning warehouses within the selected range must be replaced. In addition, if the operating plan date is not equal to the first production period date, all base plans in the planning warehouse must be replaced.

When you replace the item production plans for all production families, the system does the following:

- Deletes the Item Production Plan (IPPLAN) file
- Creates a new record in the Item Production Plan file with the item number and the new production quantity
- Updates the First Production Period Date (FPPD) with the Operating Plan Date (OPDT).

When you replace the item production plans for only one production family, the system does not delete the Item Production Plan file, but updates the file for each item in the family.

Note: The First Production Period Date (FPPD) and the Operating Plan Date (OPDT) must be the same before you can replace the item production plans for only one family. If the two dates are not the same, you receive a message advising you to replace the item production plans for all families to make the dates equal.

Evaluating family production plans

Periodically, you should compare, analyze, and update the various MPSP family production plans, MPSP aggregated plans, and actual performance figures. MPSP alerts you to areas where investigation of potential problems is required, where potential change in the course of action is required, and if you are meeting the objectives of the overall company business plan.

Some of the family base plan primary evaluation purposes are:

- It is usually linked to the business plan to keep the manufacturing organization focused on overall company objectives.
- Actual performance is compared against it to highlight the need to investigate for significant performance problems and fix them.
- New family operating plans are compared against it to see how the current revised production outlook differs from the family base plan because recent underlying business environment factors have changed since the family base plan was last developed and a new course of action by top management may be necessary.

As previously mentioned, family operating plan primary evaluation purposes can be used to factor in new business environment assumptions over the planning horizon, execute to the new business conditions and still have the family base plan intact for performance measurement.

You can compare aggregated plans with the family operating plans to see how they vary and analyze the plans that require modification to keep the manufacturing organization focused in the right direction.

Variations

Using the Family Plan Inquiry displays (AML280 through AML285), you can:

- Evaluate the variations and variance percentages for all of the family plans (base plans, operating plans, and aggregated plans).
- Determine if your aggregated item production plans, aggregated item trial plans, and aggregated master production schedules are meeting your production targets for the family.

Base vs. actual performance.

- The amount the family base plan (production, demand, or inventory) quantities vary from actual (production, demand, or inventory) quantities.
- The percentage that the family base plan information varies from the actual information.

Base vs. operating plan: .

- The amount the family base plan (production, demand, or inventory) quantities vary from the operating plan (production, demand, or inventory) quantities.
- The percentage the family base plan information varies from the operating plan information.

Operating production targets vs. aggregated plans: .

- The percentage the aggregated plans (item production plans and item trial plans) vary from the production targets in the family operating plan.
- The percentage the aggregated master production schedules vary from the production targets in the family operating plan.

All the variance amounts and percentages can be positive or negative. The variance percentages are rounded.

Calculations for variations and variance percentages

You can review the following list of variations and variance percentages (rounded) and the system's calculations for them:

- Production variance on display AML282 = (Actual Receipts or Production Targets) — Base Plan Production Target
- Production variance percentage = Variance divided by family base plan production target x 100
- Demand variance on display AML283 = (Actual Sales or Operating Plan Demand) — Base Plan Demand
- Demand variance percentage = Variance divided by family base plan demand x 100
- Inventory variance on display AML284 = (Actual Inventory or Operating Plan Inventory) — Base Plan Inventory
- Inventory variance percentage = Variance divided by family base plan inventory x 100. Inventory levels by period are calculated from sales and receipts and beginning on-hand inventory associated with each plan.

Variance percentages on display AML285.

- Percentage that the aggregated item production plans vary from the production target = $((\text{Aggregated Item Production Plans} - \text{Production Target}) \div \text{Production Target}) \times 100$.
- Percentage that the item trial plans vary from the production target = $((\text{Family Net Demand} + \text{Family Adjustments}) - \text{Production Target}) \div \text{Production Target} \times 100$.
- Percentage that the aggregated master production schedules vary from the production target = $((\text{MPS Actual Receipts} - \text{Production Target}) \div \text{Production Target}) \times 100$.

Note: If the family base plan quantity or production target is zero for a period, the variance amount or variance percentage is blank.

Replacing the family base plan

If you find that the family base plan is no longer valid, you can replace the family base plan with the new family operating plan to create a new family base plan. You should also replace the family base plan with the new family operating plan during each semiannual Business Plan cycle or when business conditions change so radically that management agrees the plan should be replaced.

Note: When you replace the family base plan with the family operating plan, the system deletes the actual sales and receipts information from the periods before the date you replace the plan.

You can replace the family base plans with the family operating plans for one or all production families.

Replacing base plans for all families. When you replace the family base plans for all families, the system does the following:

- Deletes the Base Plan (BASEPL) file
- Updates the Base Plan Date (BPDT) in the Planning Information file, with the Operating Plan Date (OPDT)
- Updates the Plan Date (PLDTE) in the Base Plan file with the Operating Plan Date. The Plan Date is the Operating Plan Date of the family the last time the family base plan was replaced.

Replacing the base plan for one family. : When you replace the family base plan for only one family, the Base Plan file is not deleted. If the family is an existing family, the family's information is updated in the Base Plan file and all periods before the Plan Date (PLDTE) are set to zeros.

Note: Setting periods to zeros occurs when the Plan Date is greater than the Base Plan Date. For example, if you replaced family base plans for all families on 01/01/**, then replace family base plans for a specific family on 04/01/** (the same year), the specific family's production target and blended demand start in the fourth period of the family base plan in the Base Plan (BPPLAN) file. The first three periods are set to zeros.

Creating a base plan for a new family: You also use the replace process to create a family base plan for a new family. In this case, the system creates a new record in the Base Plan file and sets all periods before the Plan Date to zero.

Note: The Base Plan Date (BPDTE) cannot be greater than the Operating Plan Date (OPDTE) if you replace the family base plan for only one family.

Using the Family Operating Plan Report

The Family Operating Plan Report (AML271) prints the demand, inventory, and production information for any twelve consecutive periods of a family operating plan. The report shows the status of families and optionally the items, giving management a detailed look at each period.

You should print the report any time you need a copy of the family operating plan to use as a work sheet. You may want to print it each time you make significant changes to one or more family operating plans, although you can print it more often. You may find it beneficial to evaluate the family and item status shown in the report before changing production targets and item production plans.

Master schedule planning

The following topics are discussed about master schedule planning:

- MPSP planning horizons
 - Production planning horizon
 - Beginning day of the scheduling week
 - Adjusting periods at the end of the scheduling year
 - Master schedule planning horizon
 - Relation of the MPS horizon to the MRP horizon.
- Composition of master production schedules
- Preparing for master schedule generation
- Defining master scheduled items
 - Selecting a level for master scheduling
 - Master scheduled items vs. master level items
 - Codes required for master scheduled items
 - Customer order separation
 - Other important information for master scheduled items.
- Types of demand used in master scheduling
 - Independent demand
 - Dependent demand
 - Safety stock and shrinkage.
- Current demand information for planning orders (extraction)
 - Extracting independent demand
 - Extracting dependent demand for master scheduled option items.
- Planning orders
 - Assembling demand
 - Planning item orders
 - Due dates
 - Selecting item process information
 - Conflicting activities.
- Maintaining master scheduled orders
 - Supporting information that MPSP provides
 - Planned order and open order maintenance.
- Exception codes and exception messages
 - Explanations of exception codes and conditions
 - Priority of exception codes
 - MPSP exception codes in MRP.
- Releasing orders
 - Using MRP to release master scheduled orders
 - Releasing orders per customer order.
- Time fences and planning zones
 - MPSP's time fences
 - Relation of time fences to planning zones.
- Consuming forecasts (CRPLB and CRPLA).

MPSP planning horizons

MPSP helps you keep track of the passage of time and adjust your planning as conditions change.

The term horizon in MPSP indicates the extent of time within which your planning activities occur. In MPSP, the longest possible horizon is three years. If your five-year calendar contains at least three future years, you can do production planning, master scheduling, and resource planning for up to the full three years.

MPSP uses two different but related horizons:

- Production planning horizon
- Master schedule planning horizon.

These horizons are maintained by planning warehouse.

Each horizon is explained below, as well as:

- Beginning day of the scheduling week
- Adjusting periods at the end of the scheduling year
- The relation of the MPS horizon to the MRP planning horizon.

Note: You also see references to an available to promise horizon as a way to describe how far into the future you can see available to promise projections. The duration of the available to promise horizon varies from item to item and has no direct relation to the production planning horizon or the master scheduling horizon. For more information about the available to promise horizon, see "Available to promise (ATP)".

Production planning horizon

The production planning horizon is the long-range or strategic horizon for MPSP. The production planning horizon usually corresponds to the company's strategic planning zone; within this zone the company makes production and resource decisions. The maximum length is three years.

In production planning, aggregation always extends over a three-year horizon. The effective length of that horizon depends on how much information is present in related files, such as the Demand Interface file or the Family Operating Plan file. You determine the length by:

- The number of periods that you forecast within the Forecasting application
- How far into the future you receive customer orders and expected customer orders.

Controlling the length of the production planning horizon. The production planning horizon extends as far as the demand information in your production planning files extends, up to three years. The horizon starts with the period you determine when you aggregate.

MPSP determines the horizon start date from the new operating plan date you enter on the Change/Display Horizon Dates display (AML601). That date must be a period beginning date, and should be the beginning date of the period in which you are aggregating. When you select the Aggregation option (option 1 on the Production Planning menu, AMLM10), that date becomes the operating plan date. The system uses the operating plan date to project 36 or 39 periods into the future (the exact

number depends on the type of scheduling periods you select when you answer the installation questionnaire for MPSP or FCST). The operating plan date also establishes:

- The Base Plan Date (if you replace family base plans)
- The Item Production Plan Date (if you replace all item production plans).

For best use of the production planning horizon, you should coordinate the periods of demand information loaded in the Demand Interface file, the new date you set for the operating plan date, and the times when you replace family base plans or item production plans.

Setting the length of your production planning periods. In MPSP, you set the length of your production planning periods (scheduling periods) when you answer the installation questionnaire for MPSP or FCST. The length you choose defines the periods:

- For production planning
- For master schedule planning beyond the number of weekly periods used
- For rough-cut capacity planning beyond 52 weekly periods.

The MPSP manuals refer to these multi-week scheduling periods as production planning periods even if you do not use MPSP to do production planning.

You must use one of the following lengths for your production planning periods:

- 12 monthly periods per year, using calendar months
- 13 four-week periods per year
- 12 periods of four- or five-week lengths in a pattern that you decide.

The following list summarizes how to set the length you want for your production planning periods:

Period length	How to set the length
12 calendar-month periods	On the installation questionnaire, type in 0 (12 monthly periods/year) for question on entering the type of manufacturing periods.
13 four-week periods	On the installation questionnaire, type in 1 (13 four-week periods/year) for question on entering the type of manufacturing periods.
12 user-defined periods of four or five weeks each	On the installation questionnaire, type in 2 (12 four-week or five-week periods/year) for question on entering the type of manufacturing periods. For questions L10 through L14, type in the pattern of weeks you want for that quarter of the year.

Notes:

1. If Forecasting is installed and interfacing, your answers to these questions should be consistent with your answers to the same questions on the Forecasting questionnaire.
2. If you select user-defined periods, the system projects all three years of the MPSP planning horizon according to the four- and five-week patterns you set in answering the questionnaire. For example, if you specify five weeks for the first period of the second quarter of the scheduling year, the first period in the second quarter of each of the three years includes five weeks.

3. Converts first year forecasts into weekly forecasts to support a first-year master scheduling horizon made up of weekly and multi-week periods. The remaining years are in multi-week (forecasting) periods.

Beginning day of the scheduling week

If you use 13 production planning periods or 12 user-defined periods, each period begins on the day of the week that you set in the questionnaire when you answer the question on defining the first day of your scheduling week. If you use 12 monthly periods, each production planning period begins on the first day of the month.

Each weekly forecasting period, master scheduling period, resource testing period (for testing master scheduled orders), or Available to promise period begins on the day of the week you set.

Adjusting periods at the end of the scheduling year

If a year includes 53 weeks (53 week-beginning days), the system automatically includes the additional week with the last scheduled week of the last quarter. For example, if you use a 4-5-4 pattern for the fourth quarter, the last period has five weeks in a year with 53 weeks.

If a year ends within a scheduling week, the weekly period takes precedence. For example, if you select Monday as your week (and period) beginning day, the first period of the new year could start on Monday, 1/4; and forecast for 1/1 through 1/3 remains in the last weekly period of the old year.

Master schedule planning horizon

The master schedule planning horizon has the following characteristics:

- Maximum length can be three years.
- User controls the exact length of the horizon.
- Horizon can include a combination of weekly periods and multi-week (production planning) periods.

You can do master scheduling for up to three years. Up to the first 52 master scheduling periods can be weekly periods. You set that number of weekly periods in the Forecasting questionnaire when you answer question on the number of first year period forecasts to be converted to weekly forecasts.

If possible, you should use weekly periods at least to include the longest CMLT of any master scheduled item plus enough weeks to ensure that component orders scheduled within the item's CMLT reflect normal production rates and quantities. Converting to production planning periods within a few weeks of the CMLT can cause excessively large component orders inside the CMLT that result from the large production planned quantities due at the beginning of each production planning period.

The more volatile the demand patterns for your master scheduled items, the more weekly periods you should include in your master production schedules. However, you should also avoid specifying more weeks than necessary, because the additional detail to be calculated can cause longer response times and run times.

After the number of weekly periods you specify, the system plans master production schedules in the longer periods that you selected for production planning. MPSP uses the longer planning periods to the end of the master scheduling horizon.

You control how far into the future your master production schedules are planned when you set the number of weeks (cutoff weeks) in the master scheduling horizon. The horizon extends that many weeks into the future from the MPS Current Date, which you also set. The horizon begins at a calculated Start Date, set back from the MPS Current Date by the number of overdue days you specified in MRP. MPSP maintenance displays and report show any open or firm planned orders that exist outside the horizon.

By limiting the length of the master scheduling horizon, you control the flow of orders into MRP for component planning. The only items that MRP can plan beyond the master scheduling horizon are MLI items that you did not consider important enough to designate as master scheduled items.

You can also use the length of the master scheduling horizon to separate tactical (short-to-medium range) planning from strategic (long-range) planning. Figure 2-4 shows:

- Tactical planning, as defined by master production schedules, for the next 18 months (18 production planning periods)
- Strategic planning, as defined by production plans, for the remainder of the production planning horizon (to three years)
- A master production schedule with 40 weekly periods and nine multi-week (production planning) periods
- An item CMLT of 20 weeks (100 work days), with weekly periods extending beyond it by another 20 weeks to ensure that component scheduling is not distorted by large item production plan quantities
- The MPS Start Date back-scheduled from the MPS Current Date by a specified number of Overdue Days (OVDP).

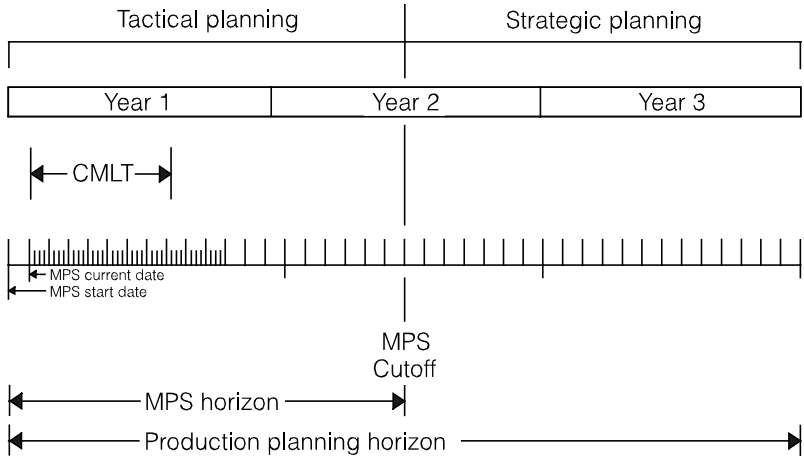

Figure 2-4. Using MPSP horizons for tactical and strategic planning

Relation of the MPS horizon to the MRP horizon

The master schedule planning horizon and the MRP planning horizon are not the same; but they must align closely, and you must coordinate changes in the two horizons carefully.

The MPS Current Date and the MRP Current Date let you synchronize the component planning in MRP with the master schedule planning in MPSP. You should set the MPS Current Date to be the same as the Current Date you use in MRP for the next MRP planning run that transfers master scheduled orders. Similarly, the MRP Current Date for a planning run that gets master scheduled orders should be the same as the MPS Current Date used in generating those master scheduled orders.

Figure 2-5 shows the relationship between a master production schedule horizon and an MRP planning horizon and suggests a typical sequence of MPSP and MRP activities:

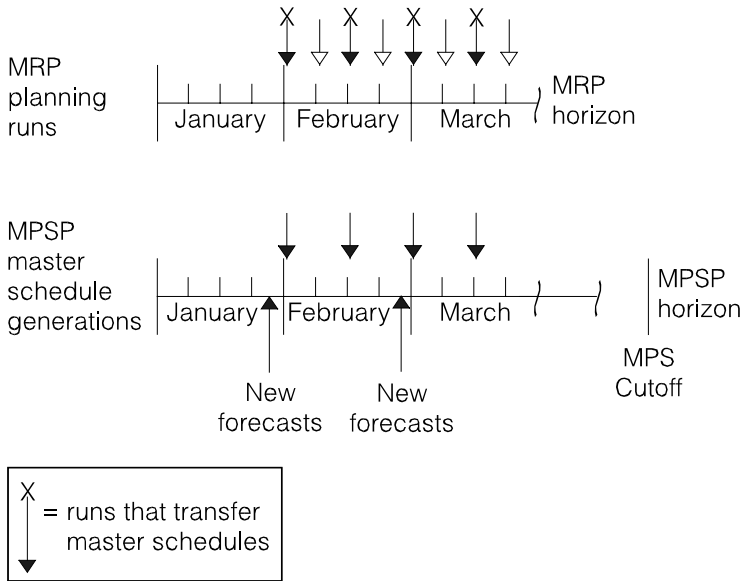

Figure 2-5. MPSP and MRP planning horizons

- Marketing produces a new forecast in Forecasting sometime during January and loads it in the Demand Interface file.
- Change the MPS Current Date to the beginning of the first weekly period in February (date A). Generate and adjust new master production schedules using the new forecast. This should be your heaviest time of master scheduling because you are responding to the changes resulting from the new forecast.
- Change the MRP Current Date to be the same as the MPS Current Date and perform a full MRP planning run, transferring orders from the new master production schedules to MRP. After MRP has transferred the master production schedules, you can change the MPS Current Date to date B. In this way, you can begin generating new master production schedules without affecting MRP's planning.

- During the first two weeks, do net change planning in MRP, or do a full planning run without transferring master scheduled orders again.

Note: In a net change planning run, you should not change the MRP Current Date or transfer orders from MPSP. Changing the MRP Current Date causes MRP to replan all items. Transferring MPSP orders cause MRP to consider most items active and to replan them. The resulting processing time may be longer than for a full MRP generation.

- The next week (date B), perform another full MRP planning run, transferring master scheduled orders again. Although this example shows master scheduling every two weeks, to keep your schedules current, you should generate master production schedules one time per week and transfer orders for a full MRP generation at least one time per week.

As Figure 2-4 shows, you can perform MRP planning runs (full or net change) as often as you need, using the same master production schedules and not changing the planning horizons. If your company generates master production schedules more often (for example, one time per week), you can transfer the new master production schedules to MRP as soon as you are ready for the next MRP run. However, the MRP Current Date must always be equal to the MPS Current Date of the master production schedules you are using.

Composition of master production schedules

In its simplest form, a master production schedule is a list of orders (open, firm planned, and planned) for an item. The orders show when the item is needed and how much of the item is needed. Master production schedules are generated by planning warehouse.

MPSP plans orders for master scheduled items based on the type of demand you specify for each item. For items whose source of demand is not item production plans, the planning process resembles MRP's planning process; that is, the system plans orders to meet demand that is not covered by inventory or expected receipts, within the lot-sizing limits (minimum, maximum, etc.) and order policy codes you specify. For production planned items, the system distributes each period's production quantity through the period based on your selection of once-per-period, twice-per-period, weekly, or daily due dates for the orders. The period quantities represent what needs to be produced. The system does not net them against current inventory because projected inventory levels were considered in setting the item production plans.

When you review or print a master production schedule, other information appears, arranged chronologically from the present (or the past, if some orders are overdue) to the future. You can see:

- The demand the master production schedule satisfies. Usually the type or source of demand is labeled, such as item production plan, blended demand, generated demand, future allocations, shrinkage, or safety stock.
- Due dates for demand as well as due dates for orders.
- Variance between the item production plan and the master production schedule (if the item uses item production plans as its source of demand).
- Inventory projections, calculated from the demand and orders shown.
- Reference information (usually in the heading) to show you the order guidelines used, such as order policy code or lot size, and the starting levels, such as available inventory or safety stock requirements.
- The status of open orders.
- Exception codes that identify recommended actions or special conditions that apply to an order.

Preparing for master production schedule generation

Before you generate master production schedules, you should be sure that:

- All related master files are up to date.
- Current demand information is available.
- The master scheduling horizon is defined.
- No conflicting activities are in progress.

Careful preparation can help ensure accurate, usable planning results.

Master files updated

Your master files should already contain the necessary information and codes for installing and running MRP successfully. In addition, be sure that you have prepared the following files for MPSP:

- Item Plan file (ITMPLN): For each master scheduled item, be sure you completed the following fields correctly:
 - Master schedule item code identifies master scheduled items and production families.
 - MPS planning source code determines the source of demand used for planning orders for a master scheduled item.
 - Order policy code controls how the system plans orders for the item (must be G for production planned item).
 - Forecasting code 1, 2, or 3 causes the Forecasting application to generate a forecast for the item, but only codes 2 or 3 pass the forecast to MPSP.
 - Days supply for a production planned item determines how the planned quantity is spread through each period (must be 1, 2, 3, or 4).

If you use it for MPSP, complete the demand time fence fields correctly:

- Demand time fence identifies a no-change planning zone for the item based on the number of days you enter.

Lead time fields should be current.

- You must enter the manufacturing lead time (LTMAN), the cumulative manufacturing lead time (CMFLT), or the cumulative material lead time (CMLMT) if you want to use the field for safety stock lead time calculation.
- You must enter a cumulative material lead time (CMTLT) if you want to use a CMLT time fence for planning and reviewing the item.
- If the item does not use a standard batch quantity, you must have an accurate lot size (LOTSZ) for it in this file.
- Product Structure file: Product structure must be accurate.
- Routing file and Production Facility file: These files must be present if you want to generate resource profiles.
- Production Family Relationship file: To retrieve master production schedules by production family, you must enter the family in this file and assign items to the family using production family file maintenance.

Demand information current

Verify the following:

- If new forecasts have been created, they have been loaded into the Demand Interface file and the MRP Requirements file.
- If customer backlog comes from COM, current customer orders have been entered in COM.
- If customer backlog comes from the Demand Interface file, current backlog is loaded to that file.
- Item production plans are current.
- If any master scheduled component items have parents that are not master scheduled, up-to-date manual requirements for the parents exist in the MRP Requirements file.

Master scheduling horizon defined. You have defined the master scheduling horizon by setting the MPS Current Date and a number of cutoff weeks on the Change/Display Horizon Dates display (AML601). The five-year calendar must have enough remaining years to contain the master scheduling horizon that you set. For more information, see "MPSP planning horizons" on page 2-28.

No conflicting activities in progress

If you want to generate master production schedules interactively, be sure that conflicting activities such as other planning runs are not in progress or about to start. For a list of conflicting activities, see the *CAS User's Guide* for further information about procedure conflicts.

Defining master scheduled items

Master scheduled items are the items you choose to schedule and monitor through MPSP. Many of them may be master level items (MLI) that you previously scheduled in MRP; however, after you identify items as master scheduled items (MSI), MRP no longer plans them.

Master scheduled items can be end items or component items. Usually, master scheduled items have the following characteristics:

- Their production schedules need to be monitored and controlled.
- Factors such as volatile demand or undependable forecasts make it impractical to equate their timing and quantities to forecasts.
- In ABC analyses, they are class A or B items, usually because they have one or more of the following characteristics:
 - They are critical to the production process.
 - They are relatively expensive.
 - They are produced in relatively high volumes.
- You want to control the items by a source of demand other than manual requirements entered in MRP.

Note: You can continue to plan class C items that have independent demand in MRP by automatically propagating requirements or directly from the manual requirements created by the Forecasting application.

Selecting a level for master scheduling

You should designate items as master scheduled items at the product structure level that gives you the best control of your overall production flow.

Possible levels for master scheduling. The following diagrams suggest different levels at which master scheduling may be most appropriate for different types of businesses:

- Type A shows master scheduling at the end item level. It works best for an operation where many raw materials and parts result in a limited number of end items.

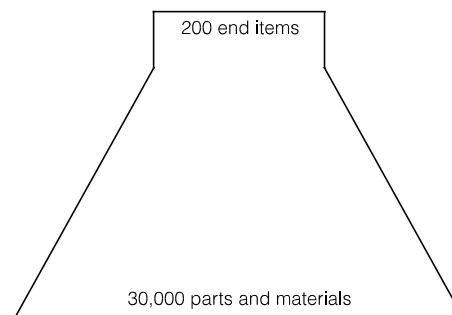

Figure 2-6. Master scheduling for type A businesses

- Type B shows master scheduling at the sub-assembly level. It works best for an operation that uses a limited number of subassemblies to produce a much larger number of end items.

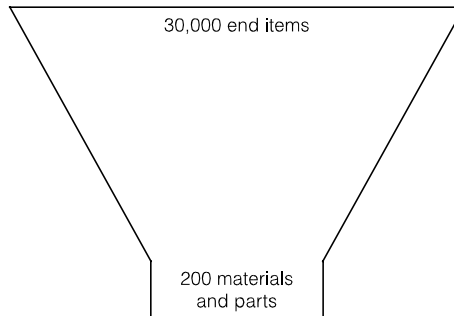

Figure 2-7. Master scheduling for type B businesses

- Type C shows master scheduling at the raw material or purchased part level. This approach works best for an operation that uses a limited number of raw materials or purchased parts to produce a much larger number of end items.

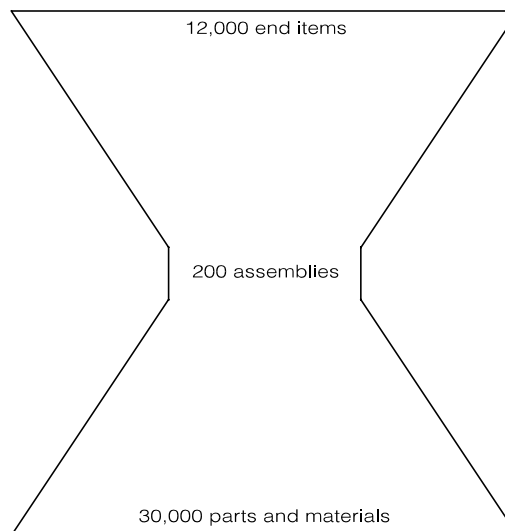

Figure 2-8. Master scheduling for type C businesses

In real life, your company may have a combination of all three types of structures depending on the products it manufactures.

- Type A is conducive to production planning and master scheduling at the end item level. You could control some lower-level service parts automatically in MRP using either the propagated forecasts = requirements technique or requirements updated by the Forecasting application. You would probably retrieve items for review or maintenance by item within family.

- Type B is conducive to a combination of production planning at the end item level and master scheduling at the end item and lower levels. For this type of business you might control some service parts and end items by propagated requirements in MRP, but you would control most service parts and end items in MPSP. You might retrieve some items for review and maintenance by item within production family and some items by low level code within planner.
- Type C is similar to type B except that the majority of your master scheduling would not be at the end item level. Production planning at the end item level would generate demand for the lower levels at which you would master schedule. Retrieval for master production schedule review and maintenance would probably be by low level code within planner.

Questions that can help you identify master scheduled items. You decide the items that should be master scheduled. The following questions may also help you decide:

- Which approach results in the smallest number of master scheduled items?
The fewer master scheduled items you use, the faster you can review the master production schedules, make changes, and prepare for new MRP runs.
- If you use sales forecasts to plan production, at what product structure level are the items that you forecast?
Usually you master schedule at the same level that you forecast.
- Which approach results in master scheduled items that you can group logically for assignment to planners?
MPSP allows retrieval of master production schedules by planner as well as by item or by production family. The items that each planner is responsible for should have common or related manufacturing dependencies.
- Do you want to use MPSP for production planning?
Production planning in MPSP uses end items grouped into production families on the basis of common resource constraints. To do production planning, you should master schedule primarily at the end item level.
- Do you intend to monitor resource requirements for production families (resource requirements planning) as well as for master scheduled items (rough-cut capacity planning)?
Resource testing for production families tells you the combined needs of the end items in those families. The more end items you cannot assign to production families, the greater the difference is between projected resource needs at the family level and projected resource needs at the master scheduled item level.
- Is processing time important?
The more master scheduled items you use, and the greater the number of product structure levels with master scheduled items, the longer the processing time is for such activities as master production schedule generation.

In general, the following principles apply:

- Concentrate your master scheduled items at the product structure levels that give you the greatest control of your overall production flow.
- Use the smallest number of master scheduled items at the smallest number of product structure levels possible.
- If you want to use MPSP for production planning, concentrate your master scheduled items at the end item level.

Master scheduled items vs. master level items

As mentioned above, master scheduled items (MSI) have certain characteristics that qualify them for control through MPSP. In contrast, master level items (MLI) that are controlled and planned through MRP, have the following characteristics:

- In ABC analysis, MLIs are usually classified as class C items, being less critical to production, less expensive, or produced in lower volumes than A or B items.
- Their demand can be approximated by forecasts or propagated requirements based on sales projections.

MLI items that are not master scheduled can be planned and controlled in MRP. However, you probably do not control these items by manually entering requirements for them. Instead, you can use the Forecasting application to project manual requirements for them automatically, or you can propagate forecasts (and requirements) for them through MRP.

Codes required for master scheduled items

Master schedule item code determines whether an item is planned and controlled in MPSP. For an item to be master scheduled, this code must be M (master scheduled item). To define an item as a master scheduled item in MPSP, you must enter the following code in the Item Plan (ITMPLN) file for the item:

The MPS planning source code indicates the type of independent demand you want MPSP to use in planning orders for the item. The code must be one of the following:

B	Blended demand; the greater of forecasts or customer/expected customer orders for the period
C	Customer/expected customer orders only
D	Blended demand, planned orders created for each customer order
E	Forecasts ignored, planned orders created for each customer order
F	Forecasts only
M	Manually entered firm planned orders
P	Item production plan

Notes:

1. If the demand type is B (blended demand), D (individual customer backlog blended demand), or F (forecasts) and you use the Forecasting application, you must also use a forecast code of 1, 2 or 3. Forecasting requires one of those codes to project forecasts for the item. You must use code 2 or 3 if you want the forecasts passed to MRP/MPSP.
2. If ISL/MISL is installed, planned intersite orders are added to both forecasts and customer orders. See "How MPSP works with ISL/MISL".
3. If the demand type is M, the system does not plan any orders. You are responsible for creating all orders for the item. The system shows the item's demand for reference only.

4. When you use demand source P, the order policy code for the item must be G; and you must enter one of the following special codes for the DAYS SUPPLY field to define how often within a production planning period you want orders planned to meet the item production plan for the period:

The following fields are in the Item Planning file (ITMPLN): 1, 2, or 3 (forecast code), G (order policy code), and DAYS SUPPLY.

- | | |
|----------|--|
| 1 | One time per week |
| 2 | Two times per production planning period |
| 3 | One time per production planning period |
| 4 | One time per work day |

Customer order separation

Planned orders can be created from customer order line items. Therefore, multiple planned orders can be created on a single day. Pegging information is created in the demand record in MSIDMD and passed to the Planned Order file MSIORD. This information is eventually transferred to MRP and becomes a part of MRP's Source of Demand Tracking.

For example, C1 orders a quantity of 50 wrenches and C2 orders a quantity of 70 wrenches. The forecast quantity for this item is 200. Based on demand shown for this period, the following planned orders will be created:

MSSR	F	B	C	D	E
Period					
F 200	200	200		80	
C1 50			120	50	50
C2 70				70	70

Other important information for master scheduled items

Before you generate master production schedules, you should have a number for one of the following fields:

- STD (Standard) LOT SIZE (LOTSZ) in the Item Master B-record for the item
- STD BATCH QTY (Standard Batch Quantity) (SBQTY) in the Item Master A-record for the item.

If you enter a number in both fields and the standard batch quantity is greater than one, the system uses the standard batch quantity.

If you want to see time fences when you maintain an item, you must have values in the appropriate field or fields:

- DEMAND TF (time fence) (DTFD) in the Item Plan file to see a Demand Time Fence
- CUMULATIVE MATERIAL LEAD TIME (CMTLT) in the Item Balance file to see a CMLT Time Fence.

For explanations of these fields, see the display descriptions for Item Balance file maintenance in the *Inventory Management User's Guide*.

You should also have a current bill of material for the item in the Product Structure file. The codes and related information listed here are necessary for MPSP to recognize an item as a master scheduled item and plan its orders accurately using the source of demand you choose.

Types of demand used in master scheduling

MPSP uses both independent and dependent demand in planning master production schedules. It also responds to safety stock and shrinkage requirements. The following discussion of demand includes these topics:

- Independent demand
- Dependent demand
- Safety stock and shrinkage.

Independent demand

You must specify for each master scheduled item the type of independent demand to be used for planning orders for that item. In addition, the system automatically includes some types of demand where they apply, such as shrinkage, safety stock replenishments, and time-phased allocations. If the master scheduled item is a component, the system automatically adds any generated demand from parent items to other demand for the item.

For a master scheduled end item you can specify any of five sources of independent demand. You specify the demand source to be used for planning an item by entering the proper code in the PLANNING SOURCE CODE field of the Item Planning (ITMPLN) file record for the item. The sources of independent demand are forecasts, customer backlog, blended demand, item production plans, intersite orders, and manual orders.

You can also enter firm planned orders directly to meet demand patterns or needs that do not fit easily into the five demand types.

Forecasts (MPS Planning Source Code = F). You can plan using forecasts only. Forecasts for the first year are divided into 52 weekly forecasts. If the Forecasting application is installed and interfacing, you can specify when you answer the Forecasting questionnaire how many weekly forecasts you want for master scheduling, up to 52. If Forecasting is installed and interfacing and your master scheduling horizon extends beyond the number of weekly periods you specified, the system plans the remainder of the horizon using the multi-week scheduling periods (also called production planning periods) you defined in the FCST or MPSP questionnaire.

If you use the Forecasting application, you must use a forecast code of 1, 2, or 3 in the Item Planning (ITMPLN) file record for your master scheduled items. You should also leave the following fields blank (zero) in the Item Planning for each item because they might cause duplicate forecasts and requirements for the item in MRP:

- Master Level Forecast Code
- Number of Forecast Periods
- Days Per Forecast Period.

You also should leave the Forecast Quantity field blank (zero) in the Item Balance record for each item because it might cause duplicate forecasts and requirements for the item in MRP.

When Forecasting is installed and interfacing, it generates a forecast master for all items coded with a forecast code equal to 1, 2, or 3. If an item is a master schedule item with a forecast code of 2 or 3, forecasts are loaded into the Demand Interface file. If an item is not master scheduled (master scheduled item code = blank) but is a master level item (master level item code equals M or S), FCST generates forecasts into the Requirements file if the forecast code is 2. If the forecast code is 3, FCST generates forecasts and manual requirements into the Requirements file.



Figure 2-9. Forecasting for MPSP and MRP

Note: If Forecasting is not installed and interfacing and you want to use forecasts for planning master scheduled items, you must create the Demand Interface file and load the forecasts into it. See C “Creating and using the Demand Interface file” on page C-1 for information about creating and loading the file.

MPSP consumes forecasts with customer orders. When a customer order is shipped, the customer order no longer exists and cannot offset the corresponding forecast during order planning and maintenance. Therefore, when shipments occur, the system uses two fields to record the total shipments made and consume the forecast for the period. CRPLB contains the total shipments before the MPS Current Date. CRPLA contains the total shipments after the MPS Current Date. See “Consuming forecasts (CRPLB and CRPLA)” on page 2-72 for more information about this calculation.

Blended demand (MPS Planning Source Code = B). If you use blended demand for planning, the system calculates for each period the greater of forecasts or customer/expected customer orders and uses the greater as the demand for the period.

If you set a Demand Time Fence for the item, the system ignores forecasts in periods before the one containing the time fence when blending demand. It assumes a forecast of zero for those periods.

The system can blend demand for master scheduled option items also. See “Dependent demand” for more information about blended demand for option items.

MPSP can also use the previous three types of demand (forecasts only, customer backlog only, or blended demand) in production planning. The system blends demand for production planned items using the demand information that is available for the items. As a result, if only forecasted demand is available, demand equals forecasts; if only customer backlog information is available, demand equals backlog; if both are available, demand is true blended demand.

Accumulated Customer backlog (MPS Planning Source Code = C). You can plan an item using customer backlog only. Customer backlog refers to booked customer orders plus expected customer orders if EC is installed. If ISL/MISL is installed, open intersite orders for supply by this warehouse are represented as customer orders. If ISL/MISL is installed, planned intersite orders also are included. If COM is installed and interfacing, MPSP gets current customer backlog from COM. If COM is not installed and interfacing and you use customer backlog or blended demand for planning orders, you must load customer backlog into the Demand Interface file regularly and keep it current to:

- Plan orders accurately.
- See accurate demand information on the master production schedule maintenance displays.
- Get accurate family-level demand during aggregation.
- Keep your item production plans up to date.
- Get dependable available to promise information.

See Appendix C “Creating and using the Demand Interface file” for information about creating and loading the Demand Interface file.

You can enter direct customer orders for master scheduled option items. The system also calculates dependent demand for option items generated by orders for the model. See “Dependent demand” for more information about option backlog.

Individual customer backlog blended with forecast (MPS Planning Source Code = D). You may choose to use this planning code if you desire to track an order's source of demand in PUR, MRP, IM, PC&C, or REP. With this option, a planned order is created for each customer order line item and the remaining uncovered forecast for the period (see example “Customer order separation”). Safety stock can also create a planned order and be tracked as a source of demand. Expected customer orders are included along with customer orders, but are kept separate, as detailed source of demand tracking is not done for expected customer orders.

Source of demand information is stored in the planned order record as it is created. When the planned order is passed to MRP, the MRP planning run retains the source of demand for subsequent planned orders as they are exploded to lower levels in the bill of material. Therefore, source of demand inquiries for a specific planned order or scheduled receipt can show the high level demand that created the planned order, such as, customer order, forecast, or MPSP safety stock.

Individual customer backlog with no blending (MSP Planning Source Code = E). This planning code is similar to D except that forecast is not considered in the calculation. Planned orders are created for each individual customer order line item. Safety stock can also create a planned order.

Manual orders (MPS Planning Source Code = M). You can generate master production schedules based solely on firm planned orders that you enter. MPSP processes the item using blended demand as its source of demand, but the system plans no orders for the item. You must enter firm planned orders to cover the demand shown. If firm planned orders exist, the system checks them against demand by period and issues exception messages where imbalances exist.

Exception codes X and F do not appear for manually planned items. See “Exception codes for maintaining orders and requisitions” for a discussion of codes X and F.

Item production plans (MPS Planning Source Code = P). You can use this source of demand only for planning master scheduled end items. Item production plans derive from family-level production targets, which are distributed among the members of the family. Item-level demand and inventory information are aggregated to the family one time per period so that you can adjust family operating plans (targets) and the related item production plans to follow changes in demand.

If you use item production plans to plan an item, you must specify an order policy code of G for the item, and the **DAYS SUPPLY** field must show a special numeric code to indicate how often in each production period you want MPSP to schedule orders. See “Defining master scheduled items” for more details.

If the MPS planning source code for an item is anything other than P (production plan), the **DAYS SUPPLY** field represents the number of days’ coverage each planned order for the item must provide.

For a production planned item, the system does not consider safety stock requirements, nor does it net the production planned quantity against inventory before planning orders. Netting (subtracting on-hand inventory from demand for the item) occurred during aggregation when the system calculated the net demand per period for the production family. Safety stock requirements were also considered at that time. Those calculations do not need to occur again. The system plans orders for the full, unchanged production quantity.

When you maintain the master production schedule for a production planned item, exception messages based on date changes, such as DEFER or EXPEDITE, do not appear. Instead, you see a variance quantity (VAR) at the end of each period if the total scheduled receipts for the period are more or less than the production planned quantity. The system identifies the difference but does not suggest an action. You must decide what variances are tolerable and where to make any changes.

Dependent demand

MPSP plans master scheduled component items using the independent demand you define in the MPS planning source code for each item plus any dependent or generated demand. Dependent demand is demand that is caused by orders for the item’s parent. MPSP can use the following kinds of dependent demand:

- Generated demand from orders for parents
- Time-phased manufacturing allocations
- Option backlog
- Option forecasts.

Generated demand from orders for parents. For a master scheduled component item, the system calculates generated demand for the item based on firm planned and planned orders for the parent item. If the parent is not master scheduled, the system gets manual requirements for the parent from the MRP Requirements file, if any exist, and pseudo-plans the parent. That is, the system executes all planning logic for the parent but retains only the calculated date and quantity requirements for the master scheduled component item. MPSP plans the parent using the same logic as MRP.

Time-phased manufacturing allocations. For a master scheduled component item, the system retrieves the allocations, the quantities assigned to released manufacturing orders. It dates the allocation back from the order due date by the component's lead time, and totals the allocations by day. Time-phased allocations are the quantities assigned for use after the item's lead time date (current date plus the item's lead time) or after the current allocation date for the item, whichever is earlier.

The current allocation date is the current date plus the number of allocation days (ALDP) for the item.

Option backlog. Generated option backlog is the demand created from customer orders for a model whose S-number configuration specifies this option item.

The due date of this demand is the due date of the customer order for the model minus the lead time of the model (end item). MPSP groups option backlog by end item and summarizes the option backlog at intervals determined by the frequency of option forecasts for the same end item. For example, if option forecasts from planned orders for a model occur at 1/7 and 1/24, all option backlog generated by customer orders for that model and due on days 1/7 through 1/23 appear immediately after the option forecast quantity at 1/7.

An option item also can have independent demand if you enter customer orders (backlog) exist for it as a service part.

Option forecasts. MPSP can generate forecasted (approximate) demand for an option based on planned orders for the model. MPSP calculates the forecasted quantity for the option by multiplying the planned order quantity for the model by the Feature/Options Planning Factor (FOPPF) of the option item. MPSP dates the option forecast back from the due date of the order for the model by the lead time of the model.

MPSP does not summarize or combine option forecasts. If an option has demand from planned orders for more than one model, MPSP lists the generated quantities separately, followed by the option backlog that consumes that forecast. These details let you compare option forecasts with option backlog and may help you determine whether you need to adjust your feature/option planning factors. For more information about option forecasts, see "Planning orders".

Safety stock and shrinkage

Although safety stock and shrinkage are not true demand, they can cause MPSP to plan orders or increase the size of orders.

Safety stock. The system plans an order, if necessary, to keep projected inventory at or above the safety stock level you specified for the item. The system plans the order at one of four time fences specified in the MRP Planning Run Execution Options, AMM151, for the planning warehouse. The four time fences are the MRP current date, purchase or manufacturing lead time (based on the lead time code), cumulative material lead time, or cumulative manufacturing lead time. The last three time fences are computed from the MRP current date. The REF (Reference) field of the master schedule maintenance display or the Master Schedule Planning Report identifies where demand exists because of a safety stock requirement.

An order defer message is only issued inside the safety stock lead time if the projected balance on an order's due date is already above the safety stock level.

Shrinkage. MPSP uses the shrinkage factor for the item (if you specified one) in calculating planned order quantities. It shows you the quantity of each order that you can attribute to shrinkage.

Current demand information for planning orders (extraction)

Master schedule planning uses a process called extraction to gather current demand information for planning orders. Extraction gets customer orders, expected customer orders/intersite orders, and forecasted demand at the time you generate master production schedules. The system uses that information to calculate the independent demand for each master scheduled item and puts the extracted demand into the Master Schedule Item Demand file. It recreates the file as part of each extraction.

It retrieves the option backlog for option items based on customer/expected customer orders for the model. It also retrieves manual requirements for nonmaster scheduled items that have master scheduled components. However, extraction does not retrieve open orders, as MRP's extraction does. MPSP retrieves open orders in the planning program.

Extraction occurs as part of master production schedule generation if the EXTRACT field on the Generate Master Schedules Planning Run Options display (AML410) is Y. If the system determines that major changes in your demand files or certain file errors make extraction necessary for a valid planning run, the system puts Y in the field and does not allow a change.

You can generate master production schedules without extracting. Then the system uses demand information from your last extraction. You may want to plan without extracting if:

- You recently extracted (today or yesterday).
- You have had very little customer backlog or forecast activity since you last extracted.
- You want to save processing time.
- You want to plan level by level.

However, as soon as demand changes significantly, it is essential that you extract in the next master schedule planning run.

When you extract as part of the planning run, the new demand information lets you see whether you need to adjust existing open orders and firm planned orders to match increases or decreases in demand. The system recalculates projected inventory for each item to show its expected period-end inventory levels.

For items with a source of demand of forecasts, customer/expected customer orders/planned intersite orders only, or blended demand, the system shows you the demand and suggests changes you might make to existing open and firm planned orders to better align existing orders with demand. The system cannot change open or firm planned orders automatically, but it does recalculate all planned orders to align future production with the changed demand.

Extracting independent demand

Master scheduled items. For each master scheduled item, extraction gathers forecasted demand and customer backlog, according to the MPS planning source code for the item. It accumulates the demand by period. The demand for weekly periods is due on the first day of the week. You selected that day when you answered the questionnaire.

Extraction ignores all manual and propagated forecasts or requirements entered in MRP for master scheduled items.

- Planning source code B, C, D, or E:

If the planning source code for the item is B (blended demand), C (customer backlog only), D (blended individual customer backlog), or E (individual customer backlog), the system gets customer backlog from COM (if it is installed and interfacing), expected customer orders from EC/MRP, and intersite orders from ISL/MISL, or your input from the Demand Interface file.

If backlog information comes from the Demand Interface file, you must keep the information current to get accurate order planning.

- Planning source code B, D, F:

If the planning source code for the item is B (blended demand), D (blended individual customer backlog), or F (forecasts), the system gets forecasts from the Demand Interface file, which is loaded by the Forecasting application (if it is installed and interfacing) or by the user. The system reduces forecasts for the current period by inventory shipments to get the unconsumed forecast for planning or blending.

- Planning source code B or M:

If the planning source code for the item is B (blended demand) or M (manually entered firm planned orders), the system blends the demand for each period to determine whether forecasted demand or customer backlog is greater. If the item's planning source code is B, the planning program uses the greater of the two when planning orders for the period. If the planning source code is M, the system shows the demand for reference but does not plan any orders for the item.

- Planning source code E:

If the planning source code is E (individual customer backlog), the system gets customer backlog from COM (if it is installed and interfacing), or from the Demand Interface file.

- Planning source code P:

If the planning source code is P (item production plan) and the item is an end item, the system puts a dummy record for the item in the Master Scheduled Item Demand file so that the planning program includes this item when it is planning level zero items.

Master scheduled option items. For a master scheduled option item, the system gets the independent demand indicated by the item's planning source code and records it in the Master Scheduled Item Demand file.

Extracting dependent demand for master scheduled option items

The system calculates most dependent (generated) demand as part of the planning program. However, during extraction the system calculates the dependent (generated) option backlog for a master scheduled option item.

Generated option backlog results from customer orders for models with standard features. Using the S-number for the end item, the system assigns the demand quantity to the correct option. The system backs up the due date for the model by the model's lead time or by the option's lead time adjustment (LTADJ) to arrive at the due date for the option backlog. If backlog from more than one parent is due on the same day, the system does not combine the quantities.

If a model is a master scheduled item with a planning source code of C (Customer only), the options used by that model should also be master scheduled items. This allows MPSP to plan the options only to meet customer demand, and MRP plan the options through the feature/option planning factor in the product structure.

Planning and demand warehouses

A warehouse is defined as either a planning warehouse, or a demand warehouse via the Work With warehouses function. The MPSP planning system assumes that all manufacturing occurs in planning warehouses, and that no manufacturing occurs in demand warehouses. If a warehouse is defined as a planning warehouse, then you may perform MPSP functions against this warehouse. MPSP will not allow you to perform MPSP functions (production planning, master scheduling, etc.) against a demand warehouse. For example, if you have three manufacturing plants, then the warehouse records for these three manufacturing plants should define them as planning warehouses.

Demand warehouses may be associated with planning warehouses. This relationship is established in the work with warehouses function. A planning warehouse may have several demand warehouses associated with it, but a demand warehouse may only be associated with one planning warehouse (see the Item override section of this manual for additional flexibility at the item level). The following example, which is used in subsequent discussions, show a potential configuration of planning warehouses and demand warehouses.

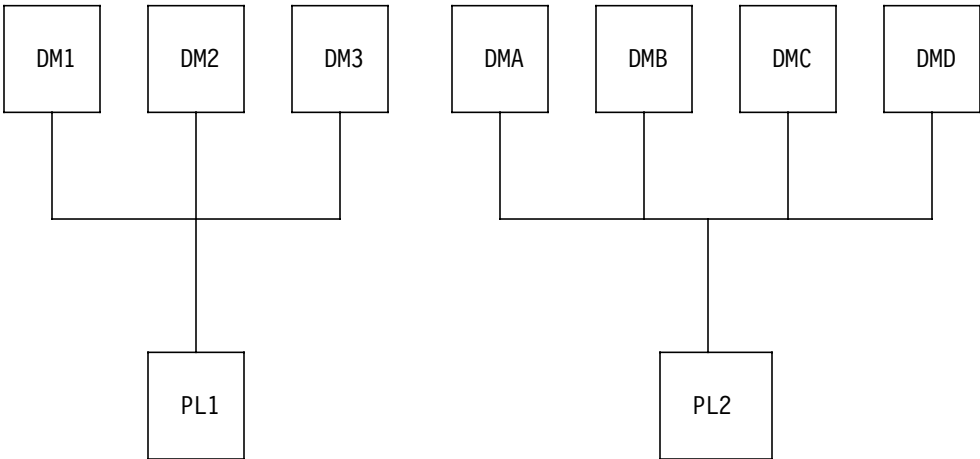

Notes:

1. PL1 and PL2 are planning warehouses
2. DM1, DM2, DM3, DMA, DMB, DMC, and DMD are demand warehouses.

The association of demand warehouses to planning warehouses serves two purposes.

One purpose is to provide a source of demand for a given planning warehouse. All of the customer orders and selected expected customer orders for demand warehouses are viewed by their associated planning warehouse. If the item is coded properly in the Item Plan (ITMPLN) file, the independent demand (customer orders and expected customer orders) is extracted into the Master Schedule Item demand.

The other purpose of associating demand warehouses with a planning warehouse is to define the supply network for a given planning warehouse. All of the inventory for

demand warehouses will be viewed by their associated planning warehouse. If item X has an on hand quantity of 100 in planning warehouse PL1, and 50, 50, 50 in demand warehouses DM1, DM2, and DM3 respectively, then for planning purposes, item X has an on hand quantity of 250 (100 + 50 + 50 + 50).

You can choose to override the consolidation of a demand warehouse's inventory by a code specified in the Item Balance (ITEMBL) file. This code defaults to 1 (1=Yes include inventory) for all items. If this code is changed to zero (0=Do not include inventory), then the inventory for the item selected in the warehouse selected will not be consolidated for planning purposes. The result of this, however, will result in a potential overstating of the items net requirements.

Multi-warehouse planning

Only planning warehouses can be planned by a planning generation. Demand warehouses cannot be planned directly. However, if they have a primary planning warehouse (specified in work with warehouses), they will be planned with that planning warehouse.

The planning system assumes that all manufacturing and purchase orders will be scheduled through a planning warehouse. All planned orders will be generated for the planning warehouse and they can be released only to the planning warehouse. Scheduled receipts and manufacturing allocations in demand warehouses will not be visible to the planning generation.

Only items which have an item balance record in the planning warehouse will be planned on a planning generation. In the multi-warehouse planning environment several demand warehouses may be associated with one planning warehouse. When planning for an item, all of the item balance records for an item (the planning warehouse and the associated demand warehouses) is considered. For example, if item X has an on hand balance of 100 in the planning warehouse and 50, 40, and 30 in the associated demand warehouses, for planning purposes, the onhand balance is 220 (see "Include/exclude inventory" later in this chapter). This field is considered a consolidated field. Other fields will just take on the value of the planning warehouse record, such as the item class (there is no logical way to consolidate the item class field). The following is a list of fields which will be consolidated from the Item Balance file.

MOHTQ	On hand total quantity
SAFTY	Safety stock
RPFLG	Requirements planning activity flag

With the exception of the above listed consolidated fields, all planning parameters specified in demand warehouses (such as order policy code, minimum order size, multiple order size, etc.) are not considered in the planning generation. Only the planning parameters from the planning warehouse are used for planning purposes.

Defining component warehouses as demand warehouses

If you supply your manufacturing location from multiple parts warehouses, you may define them as demand warehouses connected to the particular planning site. MPSP will then see the inventory in those warehouses and accept it as part of the plan.

The following example illustrates the flow between one planning warehouse, multiple finished goods and component warehouses.

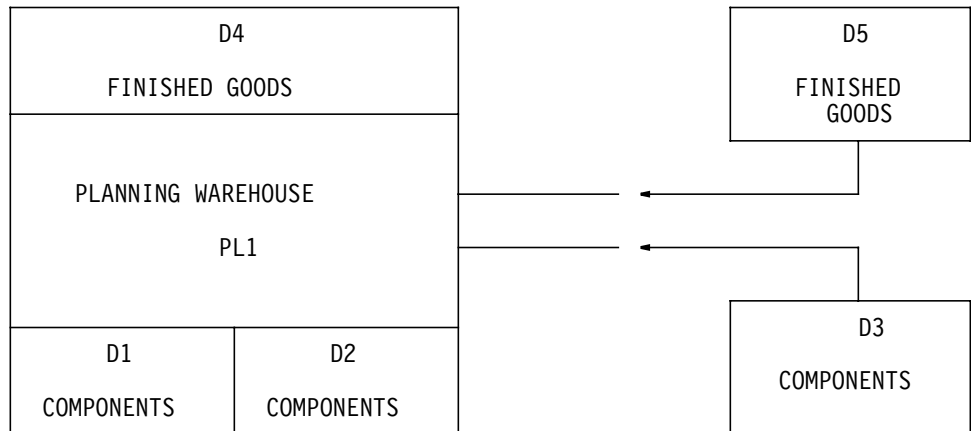

Notes:

1. PL1 = Planning warehouse
2. D1, D2, D3 = Component warehouses
3. D4 and D5 = Finished goods, service parts warehouse.

Multiple planning warehouses

Multi-warehouse supports either a “product” organization where all of item 123 is built, for example, at a plant in Moline, IL (regardless of where the demand originates), or “geographic” organization, where the product 123 could be built, for example, at a plant in San Jose, CA (if demanded from the West coast) or Raleigh, NC (if demanded from the East coast).

The following example illustrates the flow between multiple planning warehouses and multiple finished goods warehouses.

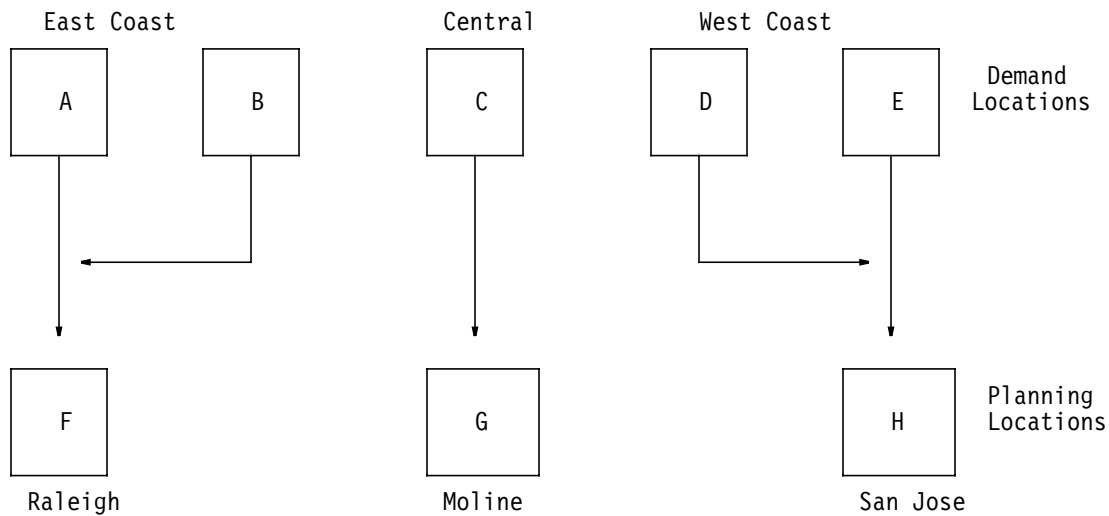

Item override

You can override the above relationship on an item by item basis to provide a product driven organization. You can say that product 123 is driven to any manufacturing warehouse we choose. Also, you can operate a mixed organization, with some parts of the product line focused on individual plants.

You can also go one step further. For instance, if item 123 is demanded from warehouse E, then make it in manufacturing location H. But in other cases, have it manufactured in F.

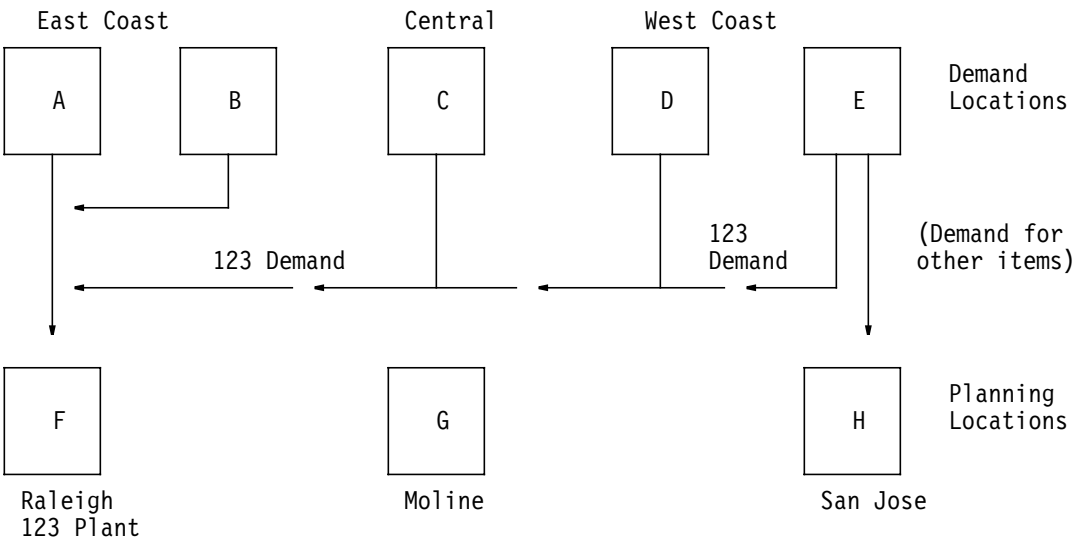

Inventory movement

The planning system assumes that all manufacturing and purchase orders will be scheduled through a planning warehouse. All planned orders will be generated for the planning warehouse and they may only be released to the planning warehouse. Scheduled receipts in demand warehouses will not be visible to the planning generation.

Because all manufacturing occurs in the planning warehouse, inventory mobility is the planners responsibility. An order may be created to cover net requirements in a demand warehouse, but the order will be scheduled in the planning warehouse and it is the planners responsibility to transfer the inventory after the order has completed. The planning generation will consolidate all of the inventory for the planning warehouse and it's associated demand warehouses. This consolidated inventory will be used to net requirements. As a result of this consolidation process, the planning generation views one pool of available inventory, and inventory movement may be necessary to cover all of the net requirements.

You may wish to use InterSite Logistics (ISL/MISL) to assist you in planning inventory movement between warehouses.

The following example illustrates that demand warehouse DM1 may have no gross requirements and an available inventory of 50. Demand warehouse DM2 may have gross requirements of 50 and no available inventory. The planning generation will consolidate the figures which will constitute an available inventory of 50 and gross requirements of 50. As a result the net requirements are 0, but the planner has the responsibility of moving 50 units of inventory from warehouse DM1 to warehouse DM2 to satisfy the demand.

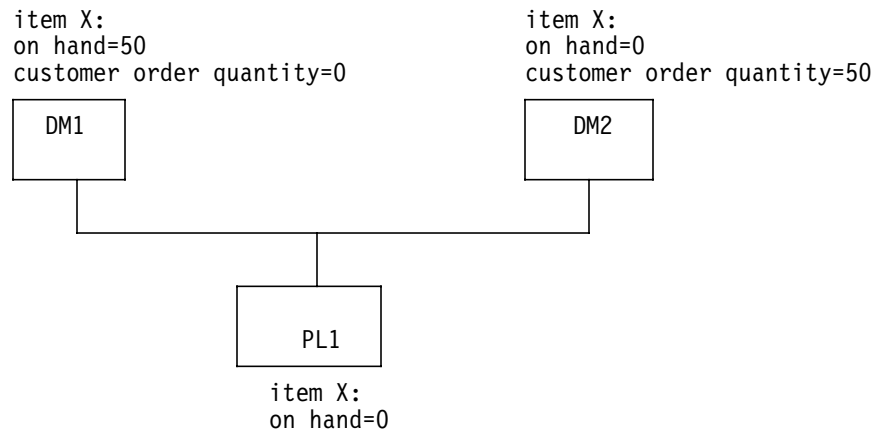

If customer orders are treated as requirements, the following planning conditions exist.

On hand = 50	(50 from DM1 plus 0 from DM2)
Requirement = 50	(50 from DM2)
Net requirement = 0	(requirement 50 minus on hand 50)

Note: The planning system assumes you may move the inventory from warehouse DM1 to warehouse DM2 to satisfy the requirement. There is no logic in the planning system to advise on inventory movement. Inventory movement is the planner's responsibility.

Include/exclude inventory

The definition of a grouping of demand warehouses that supply a particular planning warehouse implies that items may be shipped from any of those demand warehouses in response to a customer order. In some cases, this may not be true. You may want to exclude material that resides in certain demand warehouses, since that material may already be committed to a higher level plan or it may be impractical to move it.

You can accomplish this action through the use of the Include Inventory Flag in the Item Plan (ITMPLN) file. This flag is automatically set to 1, meaning that any balances for the item are available as far as MPSP is concerned. If you change the flag to "0" (zero), then any balances are invisible to MPSP and additional orders are planned as if the excluded inventory did not exist.

Examples 1, 2, and 3 illustrate the planning process and the use of the Include Inventory field in the Item Balance file.

Example 1:

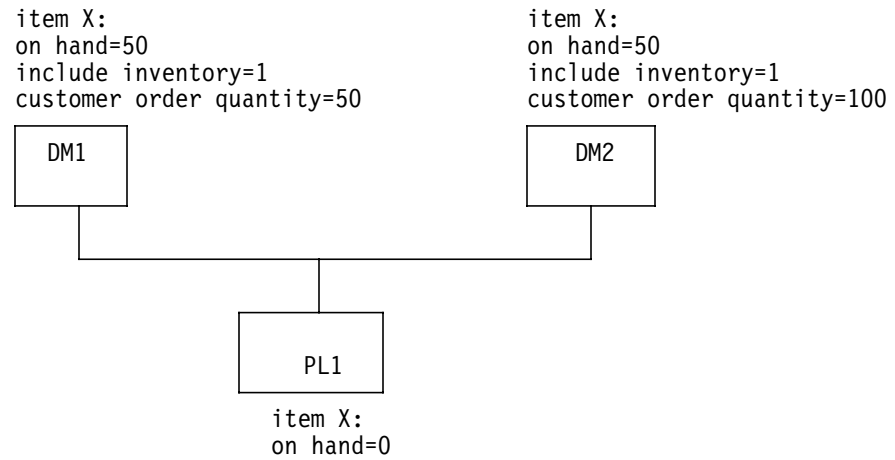

The following planning conditions exist.

On hand = 100	(50 from DM1 plus 50 from DM2)
Requirement = 150	(50 from DM1 plus 100 from DM2)
Net requirement = 50	(requirement 150 minus on hand 100)

Example 2:

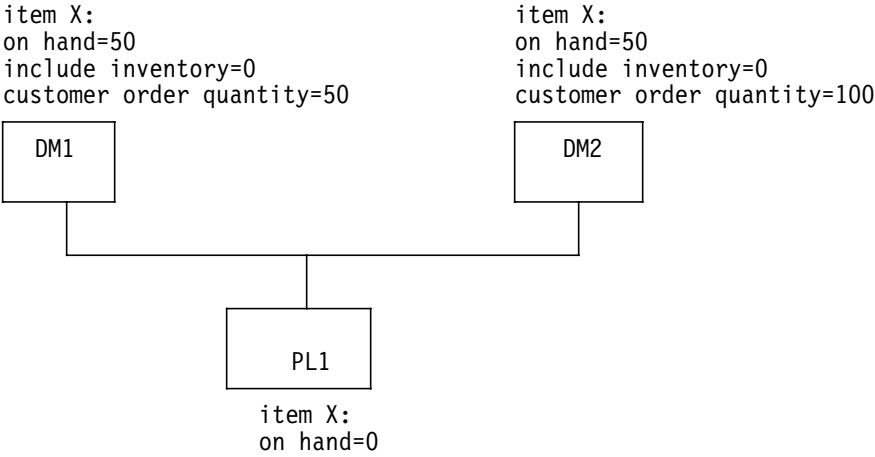

The following planning conditions exist.

- On hand =0 (50 from DM1 and 50 from DM2 are not included)
- Requirement = 150 (50 from DM1 plus 100 from DMS)
- Net requirements = 150 (Requirement 150 minus on hand 0)

Note: Even though there is a quantity of 50 on hand in warehouse DM1 and 50 on hand in warehouse DM2, the planning system ignores these quantities because of the include inventory flags set equal to 0 (zero). The result is an overstatement of net requirements (a net requirement of 150 is generated when the net requirement potentially should be 50).

Example 3:

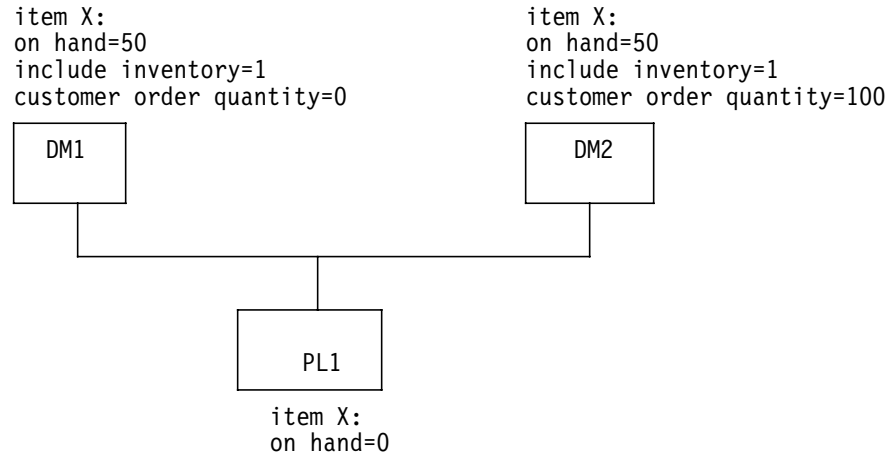

The following planning conditions exist.

On hand = 100	(50 from DM1 from 50 from DM2)
Requirement = 100	(100 from DM2)
Net requirement = 0	(requirement 100 minus on hand 100)

Note: The planning system assumes you may move the inventory from warehouse DM1 to warehouse DM2 to satisfy the requirement. There is no logic in the planning system to advise on inventory movement. Inventory movement is the planner's responsibility.

Using requisitions in planning

Requisitions can be used as coverage for demand in both MRP and MPSP. There are three options specified in the MRP Planning run Executions Options, panel AMM151, applying to the extraction of requisitions. The first option is to extract all requisitions during the generation. The second option is to use only requisitions released through MRP. The third option is not to use requisitions at all during the generation. This is a shared response for both applications.

Planning orders

Through its planning programs MPSP generates a set of time-phased orders that meet demand to the end of the master scheduling horizon. It also suggests actions you can take to keep the due dates valid for open and firm planned orders and requisitions. MPSP uses planning techniques like MRP's, but it plans orders to meet demand directly rather than meeting planner requirements based on demand. These orders, with any changes or additions you make, serve as the master production schedule for which MRP plans component items.

As described here, order planning involves two programs: one that calculates generated demand for master scheduled component items, and one that uses that generated demand and the extracted demand in the Master Scheduled Item Orders

file to plan orders and identify exception conditions. Both of these programs execute once for each product structure level planned in the master production schedule generation. If you extract current demand information for this planning run (EXTRACT = Y), the extraction program runs one time for the complete planning run; then the planning programs run.

The planning run starts with the highest level that you maintained and plans through the level that you specify. If you extract in the planning run (EXTRACT = Y), planning begins at level 0.

The following topics are part of this discussion:

- Assembling demand
- Planning item orders
- Due dates for planned orders
- Overdue demand and scheduled receipts.

Assembling demand

Before the system can begin planning orders, all the necessary demand must be available. From the last extraction, the Master Scheduled Item Demand file has the appropriate independent demand for master scheduled end items and component items. It also has dependent demand for master scheduled option items generated by customer orders for models.

The planning programs calculate the generated demand for master scheduled component items and master scheduled option items:

Generated demand for master scheduled component items. MPSP calculates the generated demand for master scheduled components from planned orders for the parent item. If the parent item is not master scheduled, MPSP pseudo-plans this MRP-planned item in the same way that MRP does, except that MPSP does not keep the orders that result. It uses them only to calculate the demand for the component items; then it deletes the orders.

To plan a nonmaster scheduled parent, MPSP gets requirements for the item from MRP's Requirements file. Therefore, the requirements for these parent items should be up to date before you start a master production schedule generation.

The demand for the component item is due when it is needed to complete the parent item's order on schedule.

Option forecast (generated demand for option items). The system calculates the generated forecast for a master scheduled option item by multiplying the planned orders for the model by the Feature Option Planning Factor (FOPPF) for the option item. The due date for the option is dated back from the model's due date by the lead time of the model or by the lead time adjustment (LTADJ) of the option item. If an option has generated forecast demand from more than one model, they are maintained separately; MPSP does not combine them.

Within each forecast interval (the time between option forecasts), the system uses the greater of option backlog or generated option forecast from each model contributing option backlog or option forecast. It plans orders to cover the total of those quantities.

For example, in the table below, an option item has option backlog and option forecasts from two models, A and B:

Due date	Quantity	Reference	Option
11/28/**	25	FC	(option forecast from A)
11/28/**	27	BK	(option backlog from A)
11/28/**	19	FC	(option forecast from B)
11/28/**	16	BK	(option backlog from B)

MPSP considers the option backlog and forecast from model A separately from the option backlog and forecast from model B. Option backlog from A exceeds the option forecast for this interval; MPSP uses 27 as the demand from A. Option forecast from B exceeds the option backlog for this interval; MPSP uses 19 as the demand from B. It plans for a total option demand of 46 (27 + 19) for this forecast interval.

If the model's planning source code is C (Customer only), the option forecast is not generated from the planned orders for that model.

Planning item orders

Planning orders for an item that is not production planned. The system begins by gathering all related demand for the item, both extracted and calculated. Then it does the following:

1. Applies available inventory to the demand.
2. If demand remains, applies schedule receipts (open orders and firm planned orders) and requisitions to the demand, issuing exception messages about date changes.
3. If any unsatisfied demand remains, plans orders to cover unsatisfied demand, beginning in the period with the last open or firm planned order, and issues related exception codes and messages.

If unsatisfied demand exists before the last firm planned order, the system plans an order to cover this demand at the date of the last firm planned order and gives the planned order an X (exception order) exception code. You can prevent the system from planning an order within the CMLT by choosing NO to "Plan orders in CMLT" on display AML410 when calling the master schedule generation. Any order required within the CMLT will be placed on the CMLT time fence and marked with an exception code of F. If you choose YES to that question, the order will be planned on the date required to meet the demand and marked with an exception code of F. If the unsatisfied demand is after the last firm planned order but before the CMLT Time Fence, the system plans an order where it is needed and issues the F (firm an order inside the CMLT) code. For more information about these and other exception codes, see "Exception codes for maintaining orders and requisitions".

For items that are not production planned, the system uses the same planning logic, lot-sizing limits, and order policy codes as MRP when planning master scheduled orders.

If you specified a shrinkage factor for an item, the orders planned for that item include shrinkage adjustments. If the item has safety stock and the projected inventory falls below the safety stock level, the system reschedules orders to rebuild inventory to that level.

If time fences exist for an item, they can affect order planning. If a Demand Time Fence exists and the item uses blended demand, the system ignores forecasts

when blending demand for periods before the period of the Demand Time Fence. If a CMLT Time Fence exists, all orders inside it should be firmed. For more information about time fences, see "Time fences and planning zones".

Planning orders for a production planned item. For a production planned item, the planning process is somewhat different. It defines demand strictly within each period, using a VAR (variance) quantity to indicate whether the planned orders meet the item production plan for the period. When planning orders for a production planned item, the system does the following:

1. Gets the planned production quantity for each period from the Item Production Plan file.
2. Does not apply available inventory against the item production plan for the period. This netting occurred during the production planning process and does not need to be repeated.
3. Reduces the quantity for the first production planning period in the master schedules by the quantity of the item already received into inventory. For more information about this calculation, see "Consuming the item production plan and item blended demand (RCPLB, RCPLA, SALBF, SALAF)".
4. The system checks scheduled receipts for Date Hi and Date Lo conditions but does not recommend changes such as Defer or Expedite because orders are created to meet the item production plan for a period and not the customer demand within a period. It calculates the VAR (variance) quantity for each period to tell you whether changes are necessary. The ideal variance quantity is zero. If the variance exceeds one multiple order quantity of the item, the variance is highlighted on maintenance displays, and the Master Schedule Planning Report (AML471) prints VARIANCE EXCEEDS LIMITS on that line of the report.
5. Using order policy code G, the days supply code, and MRP's lot-sizing rules, plans orders to meet any unsatisfied part of the plan for the period. The system begins planning orders for the period in which the last firm planned order occurs. If normal lot-sizing techniques result in quantities above the demand, the system shows those quantities as variance but applies them to demand in later periods.

The code for days supply (NODS) for the item—also called the Time Period of Supply code—determines how often and when demand is due (frequency of orders) within each period:

- Period of Supply = 1 (one order per week)

The system converts the item production plan into daily quantities by dividing the demand by the number of working days in that period to get a daily demand. It multiplies that quantity by the number of working days in a week to get the production quantity for the week. The production planned quantity is always due on the first day of its week.

The quantity for the first week of the period is due on the first day of the period. The first week extends from the first day of the production planning period to the beginning of the second week. The last week in a period ends on the last day of the production planning period.

- Period of Supply = 2 (two orders per period)

The system divides the total production quantity by two. One half is due on the first day of the period. The other half is due one-half of the total number of work days in the period after the first day of the period. For example, if the period has 22 work days, the second half of the production quantity is due 11 work days after the first day of the period.

- Period of Supply = 3 (one order per period).

The production quantity for the period is due on the first day of the period.

- Period of Supply = 4 (one order per work day).

The production quantity for the period is divided by the number of work days in the period.

For a production planning period the ideal variance is zero. Lot sizing can cause some variances, but the quantity should be small relative to the total production planned quantity for the period. You must decide whether any variance is acceptable, and how much. If you need to reduce the variance, you must decide when and how to change the orders; MPSP does not suggest changes for production planned items.

You must also decide whether the orders as MPSP has planned them are feasible within existing manufacturing limits. Rough-cut capacity planning (resource testing) can show whether the proposed master schedules exceed the limits of your critical resources.

Planning orders for a manually planned item. If the master schedule planning source code for an item is M (manually planned), the planning activity is limited. The system processes the item based on blended demand and shows the demand for reference. However, it does not plan orders for the item. If open orders or firm planned orders for the item exist, the system edits them for exception conditions.

Due dates

Due dates for planned orders. Planned and firm planned orders can be due on nonwork days. For a production planned item, this condition occurs when the first day of a production period or the first day of a week is a nonwork day. You can also make a firm planned order due on a nonwork day. In either case, the system sets the start date for the order so that it is completed on the closest work day preceding the actual due date.

Overdue demand and scheduled receipts. Customer orders and scheduled receipts (open or firm planned orders) are overdue if they are due before the first day of the current week, which includes today (the system date). For planning purposes, MPSP considers all overdue customer backlog as due yesterday, the day before the system date. Scheduled receipts must satisfy overdue demand as well as current demand.

Overdue scheduled receipts cause a DATELO (L) exception code, if the due date for the past due order matches the date of the first requirement that requires that order. However, if the past due order is either earlier or later than that requirement, the system assigns a DEFER (D) or an EXPEDITE (X) exception code. This allows past due orders with exceptions of DEFER or EXPEDITE to show the number of days off schedule.

Conflicting activities

Generating master production schedules does not require a dedicated system. However, some activities can prevent the generation from running; and other activities cannot occur while a generation is in progress.

Following are some activities that can prevent master production schedule generation from running, either interactively or from the job queue:

- Product Structure file maintenance
- Master production schedule maintenance
- Change/display horizon dates (MPSP)
- Test master production schedule resources
- Another planning run in progress.

If one of these activities is in progress when you use **F09** to start an interactive planning run, a message informs you of the conflict and lets you cancel the run or submit it to the job queue.

Some activities that cannot occur while a master production schedule generation is running are:

- Master production schedule maintenance
- Change/display horizon dates (MPSP)
- Any MPSP activity that uses planned orders, such as testing master production schedule resources
- MRP planning run
- Order release (MRP or IM).

See the *CAS User's Guide* for a complete list of conflicting procedures. Because these conflicts may affect other activities in your operation, you should schedule your generation runs carefully. Even a short planning run can affect many other system users.

Maintaining master scheduled orders

MPSP lets you review master production schedules, within a selected planning warehouse, by planner, by production family, or by item. As in MRP, you can restrict the review to items with exception conditions and to items that you have already reviewed and marked for bypassing. However, unlike MRP, you cannot exclude items with minimal exception conditions.

MPSP updates its files immediately with your changes, though in some cases you must resume Inquiry mode to see the changes on the maintenance display. As a result:

- You can make experimental changes, see the effects, test for resource requirements, and if necessary back out the changes or make further changes.
- You can make changes at one product structure level, replan that level to check for further exception conditions, and then replan one or more lower product structure levels to review the resulting changes.

You can maintain requisitions and all types of master scheduled orders—open, firm planned, and planned. You can add firm planned orders as well as change or cancel orders.

Note: Changing a planned order firms the order.

This discussion includes the following topics:

- Supporting information that MPSP provides
- Planned order and open order maintenance.

Supporting information that MPSP provides

MPSP provides the following kinds of information to help you identify necessary changes:

- Exception codes (and messages)
- Recommended dates
- Supporting details
- Time fences.

Exception codes. One-letter exception codes appear on the master schedule maintenance displays (AML452 and AML453) and on the Master Schedule Planning Report (AML471). The report also prints a short message explaining each code. The codes identify a scheduling condition that needs attention and in some cases suggest an appropriate action. See “Exception codes for maintaining orders and requisitions” for more information about these codes.

Recommended dates. For exception conditions that affect order timing, MPSP suggests a new date you can use to solve the problem. Based on the exception condition (defer, expedite, reschedule), MPSP suggests a new due date for the order. On the maintenance displays, the suggested date for an order appears in an entry field in the lower part of the display when you select a **CHANGE** action for that order. On the Master Schedule Planning Report, the recommended date prints as part of the exception message for the order. However, only one exception condition can appear or print for an order. See “Exception codes for maintaining orders and requisitions” for a list of the priority sequences in which exception codes appear.

Supporting details. The maintenance displays and reports show you information that can help you decide how to handle scheduling problems. Chronologically by period you see the demand that caused the order and cumulative inventory projections. The heading gives additional information about lead times, current receipts, and planning principles for the item.

From the maintenance displays, you can also see a detailed Blended Demand display (AML454). It shows for each period the customer order quantities and forecasts used to calculate blended demand for the item.

On the Master Schedule Planning menu (AMLM20) you can begin MRP item inquiry without stopping to sign on to MRP. MRP item inquiry can show you the peg-to relationships of the item. With that information, you can determine the source or sources of demand for a master scheduled component item.

Time fences. If you use MPSP's time fences, they provide additional guidance in making changes. The Demand Time Fence can signal the final assembly lead time, within which no changes should occur. The CMLT Time Fence shows you the point after which you can make changes fairly easily because you have time to get any additional materials or components needed and manufacture the product by a normal schedule. For more information, see "Time fences and planning zones".

Requisition, planned order, and open order maintenance

You can maintain firm planned orders, planned orders, and open orders in MPSP.

Firm planned and planned orders. Any changes you make to these orders are effective immediately. If you change a firm planned order, MPSP changes any generated demand from this item used for planning master scheduled component items at a lower product structure level. However, if you add a firm planned order, MPSP does not calculate the new generated demand until you perform a new planning run.

Open orders and requisitions. Changes to open orders and requisitions create pending change fields in the related files. An exception code of P indicates that a pending change exists. MPSP uses the changes in its calculations, such as master scheduling and aggregation; it also creates pending changes for related component allocations. However, other applications do not use the new values until you complete the changes. To do that, you must change the requisition or open order in IM or Purchasing, if installed. When you complete the change, the pending condition disappears.

If you change an open order or a requisition during master schedule maintenance, the system prints the Master Schedule Open Order Maintenance List (AML455), which lists the changes. Use that report to help you duplicate the changes in IM.

Note: MRP planning runs accept MPSP pending changes to open orders and requisitions. When MRP finds a pending change, it notifies you on the Planning Run Exception Report (AMM321) that the change was accepted. However, these changes are considered errors. If you want to use the changes, you should make them in Inventory Management or Purchasing, if installed, before starting the MRP run. If you decide that you do not want to use the changes, you must remove them in MPSP and then start the MRP planning run again to remove the error condition. It is recommended that all maintenance to MPSP orders be performed using MRP order review and approve and MRP order release, to keep MPSP and MRP in synchronization.

Exception codes for maintaining orders and requisitions

Like MRP, MPSP informs you when special planning conditions exist that need attention. Single-letter alphabetic indicators appear in the STATUS field of the master schedule maintenance displays (AML452 and AML453) and of the Master Schedule Planning Report (AML471). They are:

Code	Meaning	Type of order described
C	Cancel order	Open, firm orders, or requisition
D	Defer order	Open, firm orders, or requisition
E	Expedite order	Open, firm orders, or requisition
F	Order needs firming inside CMLT	Planned orders only
H	Date high	Open, firm orders, or requisition
L	Date low	Open, firm orders, or requisition
M	Maximum quantity exceeded	Planned orders only
P	Pending change	Open orders or requisition
R	Reschedule order	Open, firm orders, or requisition
X	Exception order	Planned orders only

These exception codes are more generic than the numeric codes used in MRP; they identify a condition or a possible solution, but in most cases they do not suggest a specific change. Like MRP's codes, these exception codes and messages are suggestions only: you decide what action to take or confirm.

The following discussion includes these topics:

- Explanations of the exception codes and conditions
- Priority of exception codes
- MPSP exception codes in MRP.

Explanations of the exception codes and conditions

Some of the MPSP exception codes are similar to MRP's; others are unique to MPSP.

C Cancel order or requisition. Other orders or requisitions are sufficient to meet demand; you no longer need this one. To prevent building inventory, cancel this order or requisition.

Note: Canceling a firm planned or planned order deletes it immediately. Canceling an open order or requisition reduces the order quantity to zero, but does not delete the order. You must delete the order or requisition through IM or Purchasing, if installed.

D Defer order or requisition. This order or requisition is no longer needed as early as it is now scheduled. Set the due date later. You may be able to combine it with another later order or requisition.

E Expedite order or requisition. The order is needed earlier than now scheduled, possibly as the result of increased demand or other schedule changes in earlier periods. You need to set the due date earlier and rush work on the order.

- F** Order within the CMLT requires firming. This code appears when the last firm planned order occurs before the item's CMLT, and an additional order is needed to cover demand between the last firm planned order and the CMLT. It also appears when there is no firm planned order, and an order is required to cover demand inside the CMLT. This code also appears if you chose NO to "Plan orders inside the CMLT", and an order is required to cover demand inside the CMLT. In this case, the order is planned at the CMLT time fence, and marked with an exception of F, to alert you that the order has been deferred to this date. The system can plan the order, but it cannot firm it; and all orders within the CMLT should be firming. You should review the order and firm it if it is acceptable.

Figure 2-10 shows how an F (order to firm inside of CMLT) exception relates to the last firm planned order and the item's CMLT.

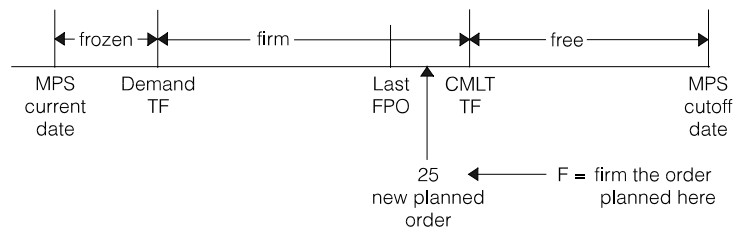

Figure 2-10. An F (firm the order) exception message

- H** Date high. The due date for this order or requisition is after the end of the master scheduling horizon (MPS Cutoff Date). If you need this order or requisition, set the due date earlier.
- Note:** MPSP cannot plan orders that are due after the MPS Cutoff Date.
- L** Date low. One of the following conditions applies:
- The due date for this order or requisition is earlier than the horizon start date.
 - The starting date for this order or requisition is earlier than the MPS Current Date and the order or requisition is still aligned with its requirement. (If not aligned, a Defer or Expedite exception message will result.)

This order or requisition is overdue and needs to be completed immediately.

- M** Maximum quantity exceeded. The present quantity of this order, or the quantity needed to meet earlier demand, is greater than the maximum order quantity set for this item. You may need to create another order or find ways to delay some of the demand.

Note: If the QUANTITY field on the master schedule maintenance displays (AML452 or AML453) or on the Master Schedule Planning Report (AML471) shows all 9s, the quantity has exceeded the size of the field.

- P** Pending change. P indicates that you changed an open order or requisition in MPSP but have not confirmed the change by making it directly to the order or requisition in IM or Purchasing, if installed. If an open order has a pending change, MPSP uses the changed information for planning and for projecting inventory balances; but other applications that use the manufacturing data base (except for MRP in its planning runs) are not aware of the change. The P (pending) code takes precedence over other exception codes that may apply to the order. They do not appear until you remove the pending condition by completing the change and replanning the item.

- R** Reschedule order or requisition. This order or requisition is needed earlier. Set the date earlier, but you do not need to expedite the order or requisition.

- X** Exception order created. This code appears because MPSP cannot plan orders inside the last (latest) firm planned order. The X code indicates that demand exceeds scheduled receipts in the period or periods before the last firm planned order. The order with this code covers the total quantity needed, and the system plans it on the date of the last firm planned order. You should replace this order with additional firm planned orders timed to meet the actual dates of the uncovered demand. The system cannot plan or change orders within the last firm planned order.

Figure 2-11 shows how an X (exception) order relates to demand not covered by existing orders, the item's CMLT, and the last firm planned order.

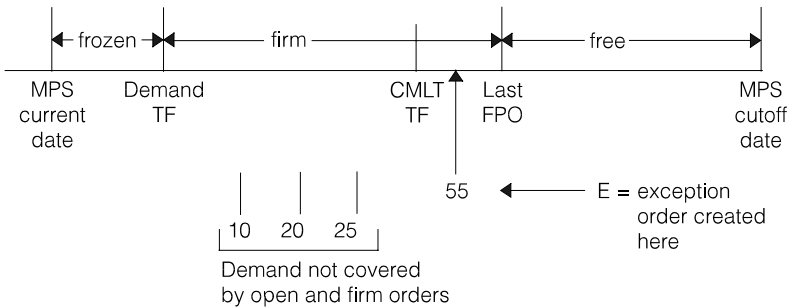

Figure 2-11. Planning an X (exception) order

Exception codes for production planned items. If an item uses an item production plan for its demand (MPS planning source code = P), the following exception codes do not apply:

- C** Cancel order or requisition
- D** Defer order or requisition
- E** Expedite order or requisition
- R** Reschedule order or requisition

For a production planned item, MPSP plans orders by production planning period. If the total scheduled receipts for that period differ from the production planned quantity for that period, the display or report shows you a variance quantity (positive or negative), and highlights the quantity if it is greater than one multiple of the multiple order quantity for that item.

When you see a variance, you must decide what to do. Your options include:

- Change the timing or quantities of the existing orders.
- Add or delete orders.
- Adjust the item production plan for the item.
- Accept the variance if it is within certain limits.
- Accept the variance because it is balanced by variances in other periods.

Priority of exception codes

The priority sequences for MPSP exception codes are listed below. The priority differs for each type of order:

Code	Meaning	Priority (by Order Type)			
		Plnd Order	Open Order	Requisition	FPlnd Order
C*	Cancel order	-	2	2	1
D*	Defer order	-	3	3	2
E*	Expedite order	-	4	4	3
F	Order needs firming inside CMLT	3	-	-	-
H	Date high	-	7	7	6
L	Date low	-	6	6	5
M	Maximum quantity exceeded	2	-	-	-
P	Pending change flag	-	1	1	-
R*	Reschedule order	-	5	5	4
X	Exception order	1	-	-	-

Note:* = not used by production planned items

MPSP exception codes in MRP

When MRP transfers orders for master scheduled items to use for MRP planning, it does not replan those orders and cannot generate MRP exception codes or messages for them. Instead, it translates any remaining MPSP exception codes into the corresponding MRP numeric codes and their related texts. For example, an MPSP master scheduled order with an exception code of H (Date high) appears in MRP with an exception code of 91 (DATEHI).

You should resolve all significant exception codes for master scheduled orders in MPSP before you transfer the orders for use in MRP. Changes you make to orders in MRP do not update the Master Scheduled Item Orders file in MPSP. As a result, you can cause MRP to plan component orders based on quantities and times not shown in your master production schedules.

Releasing orders

MPSP does not release orders directly; you release master scheduled orders through MRP's order release/review cycle.

Note: If you change master scheduled orders as part of MRP's Order Review and Release cycle, those changes may not be communicated back to MPSP. Check the order release error list to see if you must manually maintain the changed orders within MPSP.

Using MRP to release master scheduled orders

When you review a master scheduled item in MRP, the last set of master scheduled orders transferred from MPSP appears. You can then review and release those orders as you would do for MLI item orders.

When you release or maintain a master scheduled order, MPSP will be updated accordingly.

Releasing orders per customer order

When COM is installed and interfacing with MPSP and MRP, you can release a manufacturing order in MRP for an item with an S-number—that is, an item with standard features and options. You can release the order per customer order, identifying the customer order or orders you want to cover with the order you are releasing. When you select an S-numbered item for review, additional displays show you the line items for any customer order and let you release manufacturing orders for specific line items.

When you release per customer order for an S-numbered item, the system also does the following:

- Marks the option backlog detail records in the COM files as RELEASED.
- Uses the actual option orders to consume the generated forecast for the option items in MPSP. Consuming the generated option forecasts lessens the chance of overplanning the option.

If you have master scheduled option items in MPSP, you must release orders for them in MRP per customer order. Otherwise, the system does not mark the option backlog records as released and will overplan the option item in the next MPSP planning run.

Time fences and planning zones

Time fences are planning indicators that you can set to emphasize production stages for an item. The fences can identify the points in an item's production schedule when changes to the schedule become more difficult or more costly.

This discussion includes the following topics:

- MPSP's time fences
- Relation of time fences to planning zones.

MPSP's time fences

MPSP provides two time fences to help you decide how to respond to changes in demand or other conditions: a Demand Time Fence and a CMLT (Cumulative Material Lead Time) Time Fence.

Demand Time Fence (DEMAND TF). The Demand TF marks the beginning of the last production stages for an item, the interval when production should equate to actual demand. It can approximate the final assembly lead time (FALT) for the item. The system sets the Demand TF after the MPS Current Date (or the system date, if it is later than the MPS Current Date) by the number of days you specify for the item in the ***DEMAND TIME FENCE*** field of its Item Plan file record. If that field is zero, the system does not show or use a Demand Time Fence for that item.

If you specify a Demand TF for an item, the system changes the way it calculates demand for that item. In periods before the period that includes the Demand TF, the system uses only customer orders in calculating blended demand; that is, it considers forecasts to be zero for those periods. If you review a master production schedule several days after the MPS Current Date, the system recalculates demand for the item based on the new position of the Demand TF (which, at that point, depends on the system date). The repositioning of the Demand TF may cause noticeable differences between the blended demand you see for the current period and the blended demand used to plan the orders for that period.

The Demand TF marks the end of the frozen planning zone.

The Demand Time Fence reminds you that:

- All production inside the Demand Time Fence should be tied to customer orders. The system does not use forecasted demand inside the Demand Time Fence because any forecasted demand not already consumed by customer orders probably does not materialize. Components or capacity reserved for the unconsumed forecast should be made available for other uses.
- Any schedule changes inside the Demand Time Fence may cause major shifts in production schedules and should be resisted.

CMLT Time Fence (CMLT TF). The CMLT Time Fence identifies how much time you should allow for manufacturing an item if no raw materials are on hand. It identifies when you may be able to increase production levels significantly without expediting the order. Any changes before the CMLT Time Fence may cause "nervousness" in the production schedule and should be considered carefully. You can make changes after the CMLT Time Fence more easily, and the system can plan or replan orders outside the CMLT without causing exception messages. The system sets the CMLT Time Fence after the MPS Current Date by the number of CMLT days (CMTLT) you specify for the item in its Item Balance file record. If the CMLT field is zero, the system does not show or use a CMLT Time Fence for the item.

The presence of a CMLT Time Fence for an item can affect how MPSP plans the item:

- In production planning's aggregation activity, the system attempts to hold the new item trial plan equal to the existing item production plan inside the CMLT. If demand quantities have changed within the CMLT, the system shows those changes cumulatively in the first period after the CMLT. If no CMLT Time Fence exists or if it is outside the five-year calendar, the system shows new net demand and related calculations in any period where they occur.
- In master schedule planning, the CMLT Time Fence affects order planning. You can prevent the system from planning an order within the CMLT by choosing NO to "Plan orders in CMLT" on display AML410 when calling the master schedule generation. Any order required within the CMLT will be placed on the CMLT time fence and marked with an exception code of F. If you choose YES to that question, the order will be planned on the date required to meet the demand and marked with an exception code of F.

Note: The F exception code can appear only if the CMLT time fence is after the last firm planned order or if there are no firm planned orders. The system cannot plan orders before the last firm planned order. For more information about the F exception code, see "Exception codes for maintaining orders and requisitions".

The CMLT Time Fence usually marks the end of the firm phase of the master planning schedule. However, if a firm planned order exists after the CMLT Time Fence, the firm phase extends to the last firm planned order.

Relation of time fences to planning zones

Time fences mark the frozen, firm, and free phases in a production schedule. The figure below shows a master production schedule horizon with time fences:

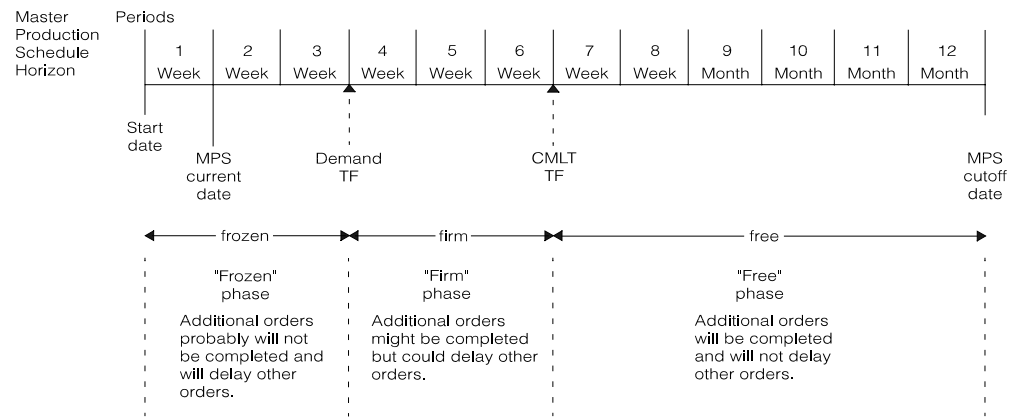

Figure 2-12. Planning phases in the master scheduling horizon

The Demand Time Fence usually marks the end of the frozen phase of an item's schedule, often equal to the final assembly lead time. In these last few days or weeks of production, any changes (especially increases) are likely to cause major schedule disruptions. Increases during the frozen phase are usually inadvisable because:

- Components are not likely to be available and there is little or no time to purchase or make them
- The shift of manufacturing resources is likely to cause delays in meeting due dates for other orders.

The CMLT Time Fence marks the boundary between the firm phase of scheduling, when some changes are possible if made carefully, and the free phase, when large-scale changes become possible with minimal impact. The cumulative material lead time (CMLT) for the item usually sets this boundary. The closer a production increase is to an item's CMLT, the greater the chance that components are available and that you can rearrange production priorities without delaying the completion of critical orders.

Note: For master scheduling, MPSP extends the firm phase when you have firm planned orders outside the CMLT. The system cannot plan orders before the last firm planned order. If you decide that additional orders are needed, you must enter them manually.

In the free phase outside the CMLT Time Fence, you can make major schedule changes with more freedom. In the free phase of the schedule, MPSP can plan orders exactly where they are needed to meet demand. However, even beyond the CMLT Time Fence you should consider how your changes and MPSP's planned orders affects the total demand on critical production resources during each planning period.

Consuming forecasts (CRPLB and CRPLA)

The system uses two fields to consume forecasted demand for an item with quantities already sold or shipped:

CRPLB Quantity shipped before the MPS current date

CRPLA Quantity shipped after the MPS current date

Each time you look at or print a master production schedule, the system uses these fields in recalculating the demand that you see for the item.

Note: If a Demand Time Fence exists for the item, that calculation overrides the CRPLB/CRPLA adjustment and sets forecasts for all periods before the period containing the Demand Time Fence to zero.

IM or COM (if it is installed and interfacing) updates these fields in the Item Balance file, based on whether the date for the quantity shipped falls before or after the most recent MPS Current Date. Each time you change the MPS Current Date for a master schedule generation, you reset the CRPLB and CRPLA fields.

The point of reference for master schedule planning is the MPS Current Date (MPCUR). That date is also the dividing date for CRPLB and CRPLA. Any shipments (or sales) between the day the generation is run and the MPCUR add to CRPLB (sales before the MPS Current Date). All shipments (or sales) occurring after the MPS Current Date are totaled in CRPLA. As soon as the system date equals the MPS Current Date, IM begins updating CRPLA (sales after the MPS Current Date).

A new master schedule generation in which you change the MPS current date resets the CRPLB and CRPLA fields. Usually the new MPCUR is after the date of the generation, and the old CRPLA has any shipments between the old MPCUR and the date of generation. Therefore, the quantity of old CRPLA becomes the quantity of new CRPLB for shipments before the new MPCUR, and new CRPLA becomes zero, ready to record any shipments that occur after the new MPCUR.

Figure 2-13 shows CRPLB and CRPLA for an MPCUR set for 5/16. If the planning run that set MPCUR occurred on 5/10, all shipments between the previous MPCUR and 5/10 are recorded in CRPLB. Shipments between 5/10 and 5/16 continue to be added to CRPLB. If you look at an item's master production schedule on 5/12, the forecasted demand shown or used for blended demand for the first period is reduced by the quantity in CRPLB. CRPLA records nothing until the system date is the same as or after MPCUR.

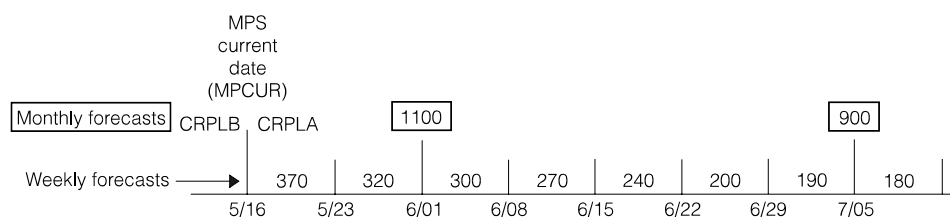

Figure 2-13. CRPLB and CRPLA (new MPCUR only)

Figure 2-14 shows CRPLB and CRPLA for an old MPCUR and a new MPCUR (set in a new master schedule generation) of 6/15. When 6/01 was the MPCUR, CRPLB recorded sales before 6/01; and CRPLA recorded sales after 6/01. If you looked at an item's master schedule on 6/04, the forecast shown or used for blending demand for that week was reduced by the quantity in CRPLA.

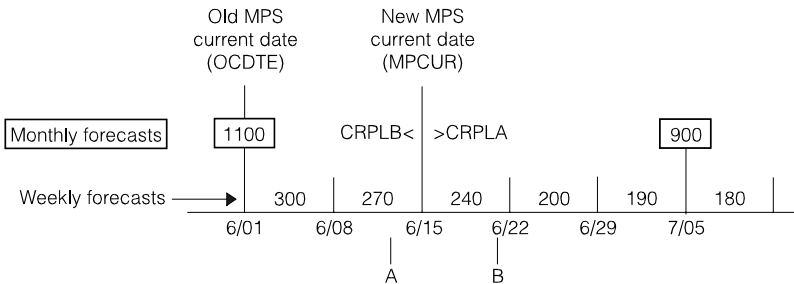

Figure 2-14. CRPLB and CRPLA: old MPCUR and new MPCUR

After the new schedule generation, the MPCUR becomes 6/15. The old CRPLB quantity is dropped and replaced by the quantity in the old CRPLA (sales after 6/01). If you look at an item's master schedule anytime before 6/15 (for example, at point A), the forecast for the first period shown is the total forecasts for periods between the old MPCUR and the new MPCUR minus the sales quantity recorded in CRPLB (sales after 6/01 and before 6/15).

Sales occurring on or after the new MPCUR (6/15) accumulate in CRPLA (sales after MPCUR). If you look at an item's master production schedule anytime after 6/15 (for example, at point B), the forecast you see for the first period shown is the total forecast for periods since the new MPCUR (6/15) minus CRPLA (sales after MPCUR).

Resource planning

The following topics are discussed on resource planning:

- Preparing for resource testing
- Critical resources
 - Defining critical resources
 - Examples of critical resources.
- Generating resource profiles
 - When to generate resource profiles
 - Basic operations
 - Using EPDM or PDM
 - Generating the profile
 - Completing the profile.
- Exploding the bill of material
 - Exploding the bill of material for a master scheduled item
 - Exploding the bill of material for a production family.
- Calculating offsets
 - Offset for components of an item
 - Offset for a work center
 - Examples of offset calculations.
- Calculating the total time for a work center
 - Information used
 - Steps in calculating work center time
 - An example of work center calculations
 - Calculating the work center capacity.
- Calculating extended quantities
 - Extended quantity for a master scheduled item
 - Extended quantity for a production family.
- Calculating resource values
 - Values for resource profiles
 - Values for resource testing.
- Using the resource conversion factor
 - Grouping related resources with different units of measure
 - Determining the conversion factor.
- Correcting lead times
- Correcting lot or batch sizes
- Testing resources
 - When to test resources
 - What happens in resource testing
 - Testing production families
 - Testing master scheduled items.

Preparing for resource testing

In MPSP, resource planning lets you project your needs for critical resources to meet your family-level production targets (resource requirements planning) or your master production schedules (rough-cut capacity planning). You do this based on the information you get from resource testing.

Some important preparations for resource testing are:

- Identifying critical resources

You should select the critical resources you want to measure and determine how much of the resource can be generated or consumed in a normal work day.

- Selecting the items to assign to production families and setting up the production families

If you intend to plan for resource needs at the production family level (resource requirements planning), you must select the items to combine into production families on the basis of critical resource usage. Then you must set up the families using production family file maintenance (option 10 on the Production Planning menu, AMLM10).

- Setting up family operating plans

You must have a family operating plan of production targets for each family you want to check for resource usage. You should start by maintaining your production families to ensure that your list of items in each family is up to date (reflect the latest item demand information). Then aggregate item information (option 1 on the Production Planning menu, AMLM10) and maintain family operating plans before testing family operating plan resources.

- Selecting master scheduled items for resource testing

You must have master production schedules for the items you want to assess for resource usage. For best results, you should test master production schedule resources after you have generated master production schedules, reviewed the schedules, and resolved any important exception conditions. Then you know that the resource projections are accurate for the orders as you use them in MRP planning. Even if an item is low-volume and low-cost, consider master scheduling it if it uses a critical resource extensively.

Note: Be sure that you have planned orders for all master scheduled levels in your bills of material before you begin testing master production schedules.

- Identifying the resource profiles to generate or create

You must have a usable resource profile for each family or item you want to test for resource needs. After you select the master scheduled items and the production families you want to include when you test resources, you must decide whether to generate a profile or create a profile for the item or family.

- Preparing the data base

You must update the data in files that affects profile generation or resource testing. Be sure that information is up to date in the Item Master, Item Balance, Item Plan, Product Structure, Routing, and Production Facility files. You also must complete some fields to support MPSP functions. For a list of those fields, see Appendix B, "Data entry in MPSP".

Critical resources

Defining critical resources

The critical resources you define should be those items or work centers that significantly affect your production. They should be your production bottlenecks, including such things as limited-supply items, limited capacity machines (or groups of machines), and specialized labor.

Whenever possible, within a planning warehouse, define the resources broadly. For example, you can consider an entire assembly department as one resource if it includes many similar work centers or operations. The critical resource may be the machine capacity, the labor hours available, or both.

Broad groupings have two advantages:

- They keep the number of critical resources to a minimum and the information at a high level. In that way, you get only the quantity and detail of information that you need to help you make your decisions.
- They keep the processing times low for generating resource profiles and testing resources.

In some cases, you may need to use very precise or very limited units as critical resources. For example, if a particular class of skilled labor is in short supply, you may want to watch the need for that kind of labor separately to help with short-term scheduling as well as long-term planning.

You must enter each critical resource in the Resource Master file. If the resource is an item with a record in the Item Plan file, you must enter the resource number assigned to that item in the **RESOURCE NUMBER** field of its Item Plan record. If the resource is a work center, you must enter the resource number used for that work center in the correct field of its Production Facility file record.

Note: For a work center resource:

- Enter the number in the **MACH (Machine) RESOURCE NO.** field if you want to measure the resource in machine hours.
- Enter the number in the LABOR RESOURCE field if you want to measure the resource in labor hours.

Examples of critical resources

The critical resources you define depend on your company and your planning priorities. They should reflect a consensus of your management about the most important, the most problematic, or the most vulnerable parts of your total business operation.

Most of your critical resources are likely to be items (including subassemblies) and work centers (including machines, skilled labor, and operational units. Some possible critical resources are:

- Critical machines. These may include all machines with a similar function, such as all lathes or all milling machines. You may want to treat some critical or bottleneck machines individually or in subgroups. Unit of measure: machine hours.

- Critical labor. This may include labor for work centers that are also monitored as critical resources in machine hours. A group of highly skilled workers with a known productivity rate can constitute a critical work center resource. Unit of measure: labor hours.
- Departments. These may be critical during specific stages of product development or manufacturing. Any group of related work centers or any operational unit with a measurable capacity can be a critical resource. Some examples of departments that could be critical resources are Engineering, Quality Control, and Testing. Possible unit of measure: man hours.
- Selected purchased items. These are purchased items or materials that are in short supply, that you must negotiate for before you know your exact needs, or that require a considerable outlay of cash to acquire. You can estimate total quantities required, and contract on that basis until you know your specific requirements. Possible unit of measure: vendor capacity, money, quantity.

You can easily include critical resources such as these in generated resource profiles as long as they are included in the bill of material or the routings for the items to be tested.

There are many other possible critical resources. If they are not part of your standard bills of material and routings, you may need to manually add them to specific resource profiles or create resource profiles for the items or production families affected. Examples of other possible critical resources are:

- Revenue to be generated
- Final assembly department
- Warehouse space required
- Advertising allotment
- Utility consumption
- Indirect manpower required
- Rate of disposal or shipment.

Generating resource profiles

When you have defined your critical resources and updated your files, you are ready to set up the resource profiles against which you can test your production schedules. You must have resource profiles for all production families and all master scheduled end items or component items whose resource usage you want to check. The processing of an item with components during resource profile generation is essentially the same whether the item is at level zero or at a lower product structure level.

You can generate the profiles automatically, by planning warehouse, or create your own profiles manually. You can adjust resource profiles (generated or manual) as necessary.

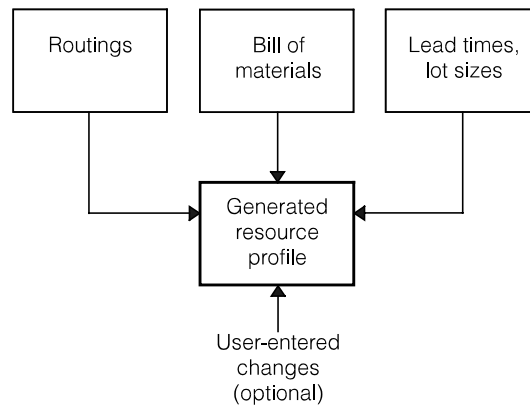

Figure 2-15. Generating a resource profile

As shown in the preceding figure, MPSP uses routings, bills of material, and lot-sizing and lead time information to generate resource profiles for all the production families and master scheduled items you want to include in resource planning. For a master scheduled item, the system explodes the item's bill of material to identify all components of the item. Then it checks all routings for all components to identify uses of critical resources and their timing (offsets) relative to the completion of the item. It uses quantity/per relationships in the bill of material to calculate the usage quantity of each resource for a standard lot or batch of an end item, or for a composite lot size of a production family.

MPSP can also generate resource profiles for production families. It creates a composite profile that combines the resource uses and offsets for all master scheduled items assigned to that family.

When you generate resource profiles, you can look at the profiles online. For each profile, you can see:

- Each critical resource used. The system creates a usage record each time it identifies:
 - A component in the bill of material that is a critical resource
 - A work center in the routings for the master scheduled item or any of its components that is a critical resource.
- The quantity and value of each usage.
- For each usage:
 - The number of days (offset) before or after an item is to be finished that the resource must be used or consumed.
 - The offset for each work center used in producing the item or any of its components.
 - The quantity of each component needed to complete a standard lot or a standard batch of the end item.

Resources applied after the item is completed, such as warehouse space or sales revenue, have negative offsets.

- The effective date of the profile (for example, you can develop your profiles relative to some future date in the planning horizon).
- The date the profile was generated or created.

MPSP provides other information to help you assess the results and correct your master file information if necessary. After a profile generation, the Resource Profile Exception Report (AML559) prints automatically. For master scheduled items, the report prints the manufacturing lead time for any component if the calculated manufacturing lead time for the component differs from the manufacturing lead time in the Item Balance file by more than a percent that you specify. It also prints lot or batch sizes for a component if the component's lot size is smaller than the extended quantity needed to produce a standard lot or batch of the end item.

After you generate profiles, you can also print the Item Resource Report (AML321) to help you assign items to production families based on resource usage. For each master scheduled item with a profile, the report prints the top five resources the item uses, in descending order of value. Resource information about items not assigned to any family prints first, followed by resource information about items grouped within families.

At the end of the generation, the system sorts the usage records for the master scheduled item by offset and by resource number, combining any records with the same offset and resource number. It then loads the usage records into the Resource Profile file as a profile for the end item. The records remain unchanged until you modify them or generate profiles again.

When to generate resource profiles

To give you accurate resource usage figures, your resource profiles must be up to date. They must include:

- The most recent information from the Item Plan, Item Balance, Routing, Production Facility, and Product Structure files
- For a production family profile, any recent changes to the production family and any major shifts in demand for the items in the family (recalculated each time you aggregate)
- Current changes, if you have maintained or created any resource profiles.

You should consider generating profiles again or revising your user-created profiles:

- After you aggregate (family profiles only) if the relationship of item demand levels in the family has changed significantly
- When you add items to or delete items from your production families (regenerate family profiles only)
- When you add or delete master scheduled items or production families
- When you change your critical resources
- When you change product structure, routing, or work center information for items that affect your resource profiles.

Note: You can create your own profiles for master scheduled items or production families if the **RESOURCE PROFILE BUILD CODE** field for the item in the Item Plan file is N. MPSP uses those profiles just as it uses generated profiles when you test resource needs for family operating plans or master production schedules. For more

information about how to create profiles or change generated profiles, see Chapter 5 "Resource Profile Management".

Basic operations

Use the figures that follow to help you understand the basic operations in generating a resource profile. Figure 2-16 shows the bill of material for a simple item (Q) with two levels of components.

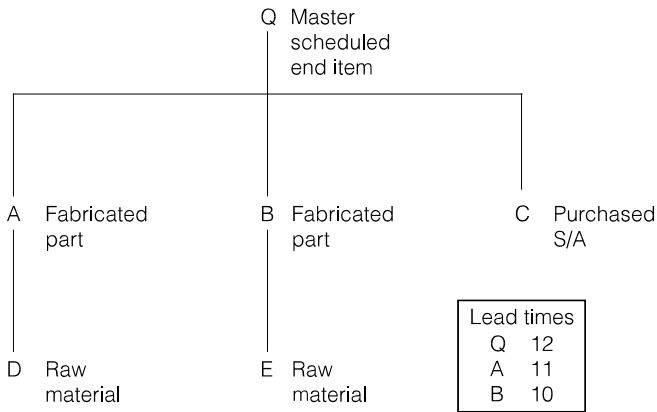

Figure 2-16. Bill of material for profile generation

Figure 2-16 also shows the lead time (LTMAN) in the Item Balance file for the item and its manufactured components. Components A and B have second-level components D and E, respectively. Items D, E, and C are purchased items and have no routings.

Figure 2-17 shows graphically how item Q is built. It shows items A, B, and Q being manufactured in their respective work centers and indicates the move and queue times for each work center. The figure also shows items D, E, and C as they are taken from inventory for use in the manufacturing process. A time line at the bottom of the figure, drawn to scale, can help you visualize the move time, queue time, and work center duration for each item.

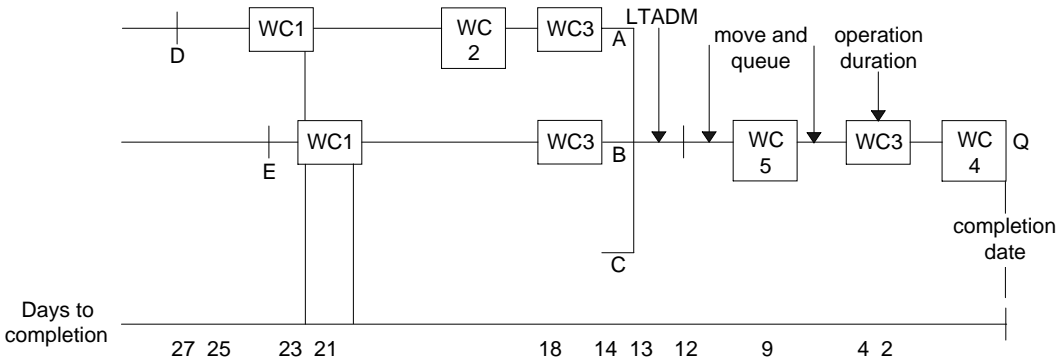

Figure 2-17. Work centers for profile generation

In broad terms, generating a resource profile for item Q would involve:

1. Doing an indented explosion to determine all possible items to consider in Q's profile.
2. Determining whether any of Q's component items are identified as critical resources in their Item Plan records and when those items are required.
3. For each manufactured component with a routing, forward scheduling the item to identify the work centers it uses and when the work centers are used.
4. Determining whether any of the work centers is a critical resource.
5. Gathering and sorting the records of all critical resource usages to create the profile itself.

Using EPDM or PDM

If EPDM is activated, determine the primary item process in effect on the date the resource is being generated for. The process determines the bill of material and routing to use.

If using PDM, only one bill of material or routing exists per item.

Generating the profile

For each item processed in the indented explosion, the system uses the following steps (see Figure 2-18):

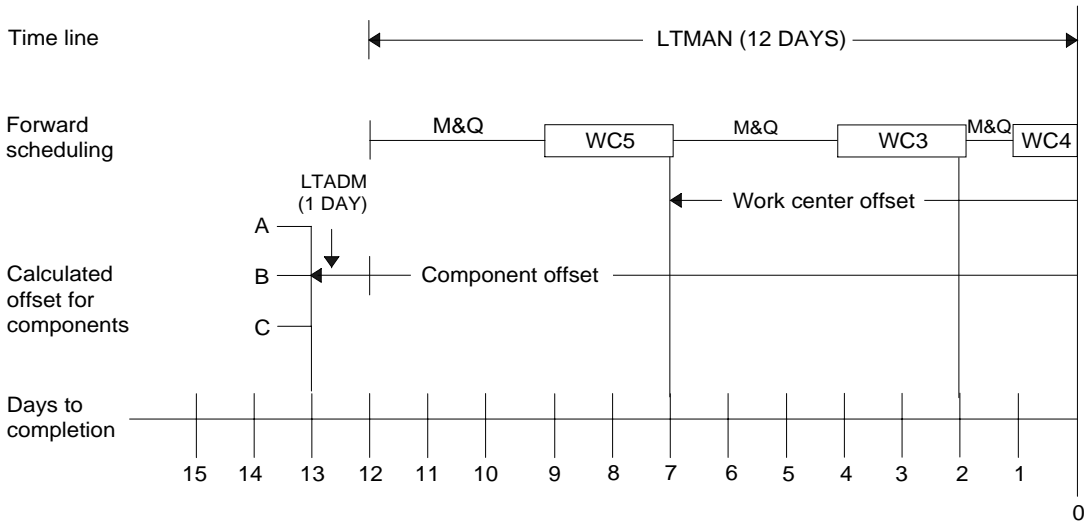

Figure 2-18. Time lines and offsets in a profile

- Creates a time line back from the item's due date equal to the LTMAN for the item. This is an approximation of the total manufacturing time required for a standard lot or batch quantity of the item after its components are available. If the time line is accurate, it determines the offset for any components of the item. The initial time line for item Q is 12 days.

Note: In actual calculations, the initial time line also includes the time from the availability of the item being processed to the due date of the end item. That

quantity is omitted from this discussion of the process to simplify the basic explanation.

- Forward schedules the item through all work centers in the routing to calculate a lead time based on information in your routings and work center files. This calculation is similar to the forward scheduling routine in the Production Control and Costing (PC&C) application:

- Uses the extended quantity of the item (standard lot size or batch quantity if it is the starting item in the explosion) as the quantity to be manufactured. If the item is a master scheduled item assigned to a production family, uses a percentage of the item's standard batch quantity or lot size equal to that item's percentage of contribution to the family's total demand at the last aggregation.

Note: If the extended quantity is larger than the standard batch or standard lot size for the item, the system prints both quantities on the Resource Profile Exception Report (AML559).

- Adds together the standard move time (MOVTM) and the standard queue time (STDQT) for the work center to determine the start of the work center operation.
- Uses the work center prime load code, scheduling capacity, standard efficiency, quantity to manufacture, routing times, and yield percentages to calculate the processing time (operation duration) for that work center. Then adds the processing time to the move and queue time to get the total work center time for that work center and determine when the operation at that work center ends.
- Examines the work center record to determine if the work center is a critical resource. If so, outputs a resource usage record to a work file. The record indicates:
 - The resource used
 - The offset of the usage (number of days before the due date of the end item that the resource must be used or consumed)
 - The quantity used
 - The value (cost) of that quantity.
- Repeats the forward scheduling calculation for each work center in the routing.
- Compares the total calculated lead time to the Item Balance lead time (LTMAN). If the difference is greater than a minimum percent that you specify at run time, prints both lead times on the Resource Profile Exception Report (AML559) for that profile generation.

Note: In the forward scheduling process, the system stores the resource usage records in a work file based on the calculated offset for the work center or component item. If your Item Balance lead time is less than the calculated lead time, a negative offset can result; if the Item Balance lead time is greater than the calculated lead, a positive offset results. In either case, the differences causes inaccuracies in the generated profile and in your resource planning. To ensure that MPSP generates reasonable profiles, you must make your Item Balance lead times (LTMAN) approximate the calculated lead times.

- Uses the calculated lead time as the true lead time. If the item being processed is a component, the system can adjust its timing relative to the end date of its end item. To determine when components of the item being processed are due (in this example, components A, B, and C), the system adds the administrative lead time (LTADM) to the calculated lead time. The total is the offset for the components.

For components of item Q (A, B, and C), the offset is Q's total work center time [(move + queue + WC5) + (move + queue + WC3) + (move + queue + WC4)] + the LTADM for Q.

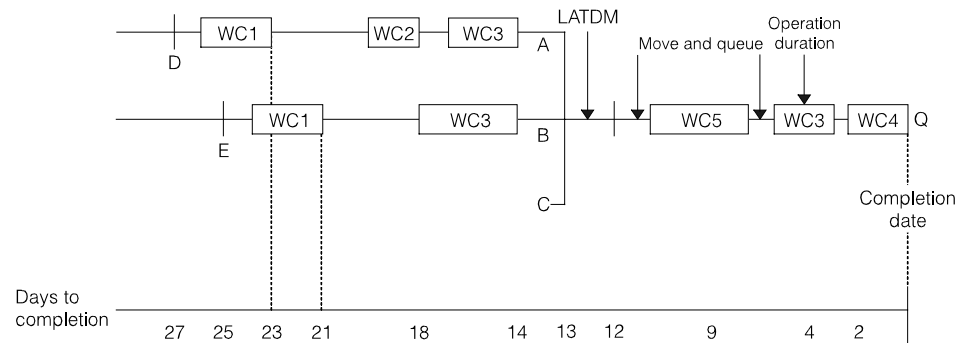

Figure 2-19. Work centers for profile generation

- **Note:** If a component has a lead time adjustment (LTADJ) in the Product Structure file, the offset for that component is its LTADJ (plus the offset of its parent).
- Continues the generation by determining whether this item has components to be processed. If components exist, checks each component to determine whether it is a critical resource. If it is, outputs a resource usage record to a work file. The usage record contains the same information as a usage record for a work center resource, described earlier. Begins the time line calculation for the first component with routings.
- If this item has no components to process, determines whether the parent of this item has other components to process. Continues until the system has:
 - Calculated offsets for all components in the master scheduled item's bill of material and for all work centers in the routings for the item and its components
 - Identified and generated usage records for all critical resources used in producing the master scheduled item.

Completing the profile

To complete the resource profile, the system must:

- Sort the usage records by offset and by resource
- Add records with the same resource number and offset
- Load the usage records into the Resource Profile file.

The information listed below represents the completed resource profile for item Q. The values shown are based on a standard lot size of 100 for Q. The critical resources are:

Critical resource	Resource number
WC1 (workcenter)	01000
WC3 (workcenter)	03000
D (item)	08000

Standard lot size = 100

Offset	Resource nbr.	Qty.	U/M	Resource cost/unit	Value
2	03000	6	hrs	15	90
14	03000	14	hrs	15	210
21	01000	6	hrs	20	120
23	01000	6	hrs	20	120
27	08000	100	pcs	.75	75

The profile includes a usage record for each time a critical resource is used in producing item Q. This sample also shows the calculated cost per unit for each resource usage. This cost is not part of the resource profile; but the system uses it to calculate the value of the resource quantity needed for each usage. The cost appears here to show you the relationship between the resource quantity and the calculated value of the quantity. Detailed explanations of the quantity and value calculations appear later in this section.

Exploding the bill of material

The basis for a generated resource profile is the exploded bill of material. Although the basic explosion process is the same, the explosion for a production family includes some steps not used in the explosion for a master scheduled item.

Exploding the bill of material for a master scheduled item

MPSP generates a resource profile for an item only if:

- The item has a lot size (LOTSZ) in the Item Master B-record greater than zero or a standard batch quantity (SBQTY) in the Item Master A-record greater than one.
- The master schedule item code for the item in the Item Plan file is M (master scheduled item).
- The Resource Profile Build Code (RSBF) for the item in the Item Plan file is Y.

If the bill of material for the master scheduled item includes a master scheduled component item, the explosion changes based on whether the master scheduled component item can have a generated profile (RSBF = Y) or has a user-created profile already.

- The system includes the component's bill of material in the profile for the master scheduled end item if the component's Resource Profile Build Code (RSBF) is N and the component does not have a user-created profile.

- The system does not include the component's bill of material in the profile for the master scheduled end item if:
 - The component's Resource Profile Build Code is Y. The component has its own resource profile.
 - The component's Resource Profile Build Code is N, and the component has a user-created profile.

For example, in the simple bill of material shown in Figure 2-20, items A and E are master scheduled items:

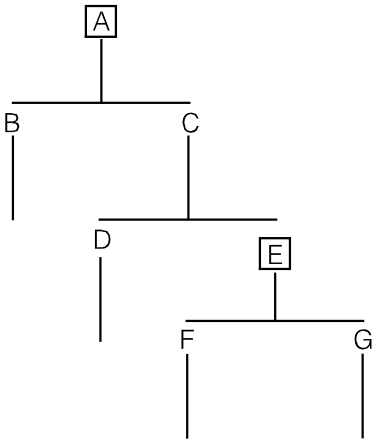

Figure 2-20. Exploding the bill of material for a master scheduled item

- If the Resource Profile Build Flag for item E is N and you did not create your own profile for item E, the generated profile for end item A includes usage information for items E, F, and G, as well as items B, C, and D.
- If the build flag for item E is Y, the generated profile for end item A includes information only for items B, C, and D. E has its own generated profile that includes items F and G.

Note: If you are using EPDM, only primary item processes are used when exploding the bill of material.

In generating a profile, the system checks the product structure effectivity dates (EDATM and EDATO) for each component of each item. Components are included or excluded based on whether their effectivity range includes the EFFECTIVE DATE OF PROFILES.

For example, the components of end item A in Figure 2-20 have the following Product Structure effectivity dates:

Item	Effective Date From	Effective Date To
B	1/1	12/1
C	1/1	12/1
D	1/1	12/1
E	1/1	12/1
F	1/1	5/30
G	6/1	12/1

Items F and G represent alternate parts used to assemble item E. As Figure 2-21 shows, the effectivity dates for F and G could affect a profile for item A, depending on the EFFECTIVE DATE OF PROFILES you specify:

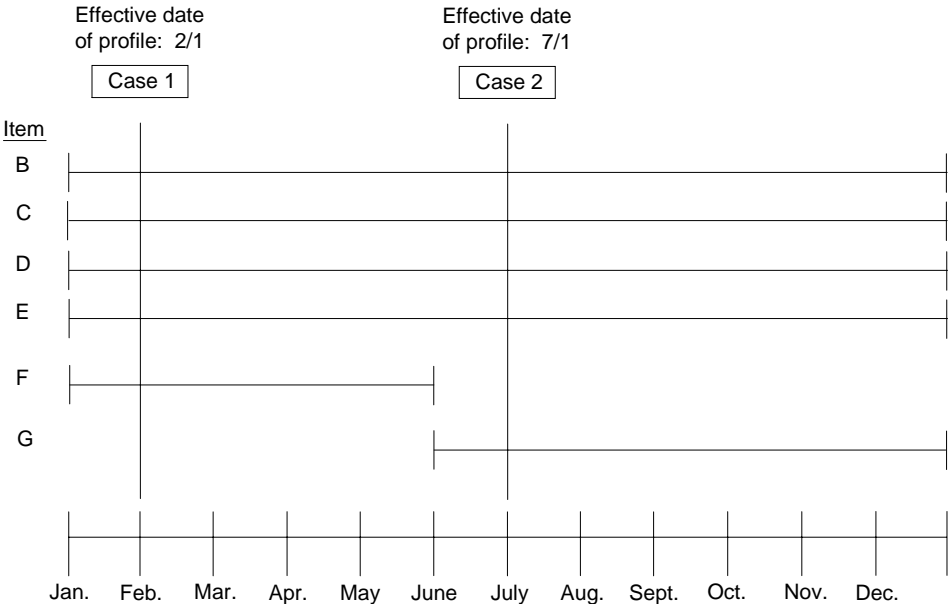

Figure 2-21. Effective date of profile

In Case 1, you generate the profile with an effective date of 2/1. The profile includes resource usage for components B, C, D, E, and F.

In Case 2, you generate the profile with an effective date of 7/1. The profile includes resource usage for components B, C, D, E, and G.

By setting the effective date, you can generate profiles that more clearly represent that part of the horizon you are interested in.

Exploding the bill of material for a production family

MPSP generates a resource profile for a production family only if:

- The master schedule item code for the item in the Item Plan file is P (Production Family).
- The Resource Profile Build Code (RSBF) for the item in the Item Plan file is Y.

For a generated profile, the system calculates a pseudo-composite lot size for the production family because no established family lot size exists. For a user-created profile, the system assumes a composite lot size of one. The composite lot size for a generated family profile is equal to the largest lot size or standard batch quantity of any end item in that family. For example, if the largest lot size of any family member is 1000, the composite lot size of the family is 1000. The system uses that composite lot size (or standard batch quantity) to calculate the extended quantities for all family members and therefore for all components of those family members.

The system multiplies the family's composite lot size by the percent of demand attributed to each member item (calculated during aggregation). The resulting

quantity becomes the lot size for the end item as the system explodes the bill of material and calculates extended quantities for components. In this way, each item's profile is weighted into a composite resource profile for the family. For more information about this calculation, see "Calculating extended quantities".

The system generates a composite resource profile for the production family. It explodes the bill of material and calculates resource usage for all members of the family, whether generated profiles for those items exist or not. If an end item uses a master scheduled component item, the system includes master scheduled component item and all of its components, regardless of its build flag. The resource usage for the family is a summation of all uses of each resource for all components of all members in the family.

The system excludes family members under the following conditions:

- The percentage of contribution of that item to the demand for the family (calculated during aggregation) is zero.
- The scheduled from date for the item is later than the effective date of profiles you specify when you generate the profile, or the scheduled to date for the item is earlier than the effective date of profiles.

In generating a composite family profile, the system also checks the product structure effectivity dates (EDATM and EDATO) for each component of each item. Components are included or excluded based on whether their effectivity range includes the effective date of profiles. See "Exploding the bill of material for a master scheduled item" for an explanation of how the effective date of profiles can affect a profile.

Calculating offsets

To generate a resource profile, the system must calculate the offset for each component in an item's bill of material. It must also calculate an offset for each work center used in a routing for the item or its components. Offsets measure the number of work days before a master scheduled item's due date that a resource is expended or used.

The offset is a combination of the following information:

- Calculated manufacturing lead times (move time, queue time, and work center operation time)
- Administrative lead times (LTADM)
- Component lead time adjustments (LTADJ) from the Product Structure file.

For a general description of offset calculations, see "Generating resource profiles". For detailed information about how MPSP calculates offsets for an item and for a work center, continue reading this discussion.

Note: Other topics later in this section also contain information relating to the calculation of offsets:

- Calculating extended quantities
- Correcting lead times
- Correcting lot or batch sizes
- Testing resources.

Offset for components of an item. The offset for the components of an item (the offset for an end item is zero) results from adding the total work center times for the item, the LTADM for the item, and the offset of the item from the end item.

The offset for a component equals:

- + Total work center time for the parent item
- + LTADM for the parent item
- + calculated offset of the parent item from the end item.

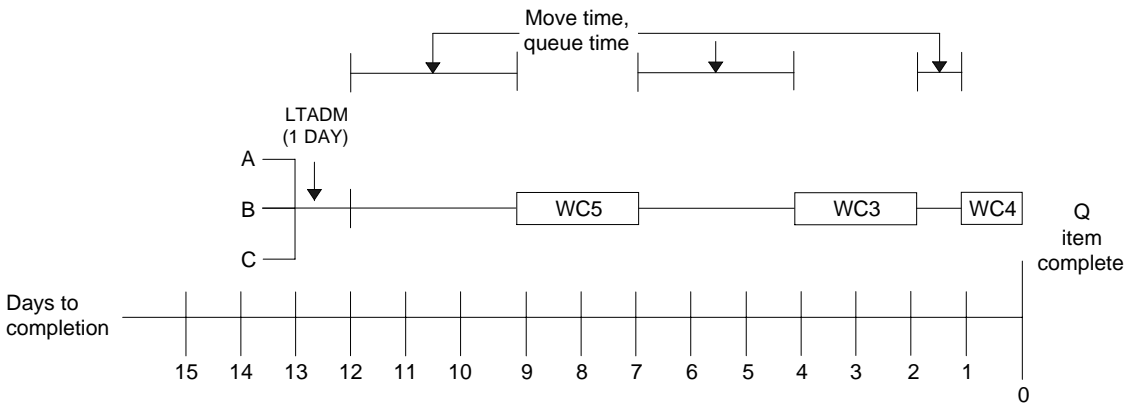

Figure 2-22. Offset for an item

In Figure 2-22, the offset for components A, B, and C is:

- 12 days total work center time for parent Q
- + 1 day LTADM of item Q
- + 0 calculated offset of the parent item from its end item
- 13 days of offset for components of Q

If the component has a lead time adjustment (LTADJ), the system uses that quantity in place of the calculated offset.

If the component resource item has a lead time adjustment, the resource offset is:

- + LTADJ of the component
- + Offset of the parent item from the end item

Offset for a work center

The system calculates the offset for each work center by subtracting the total move, queue, and processing time for each work center in turn from the remaining time line for the item (time line = LTMAN + the item's offset from the end item).

The offset for the first work center in a routing equals:

- time line of the item
- work center time for the work center (move time + queue time + manufacturing time)

The offset for other work centers in a routing equals:

- + remaining time line of the item
- + work center time for the work center

This calculation and subtraction cycle continues until the system has subtracted all work center times from the time line.

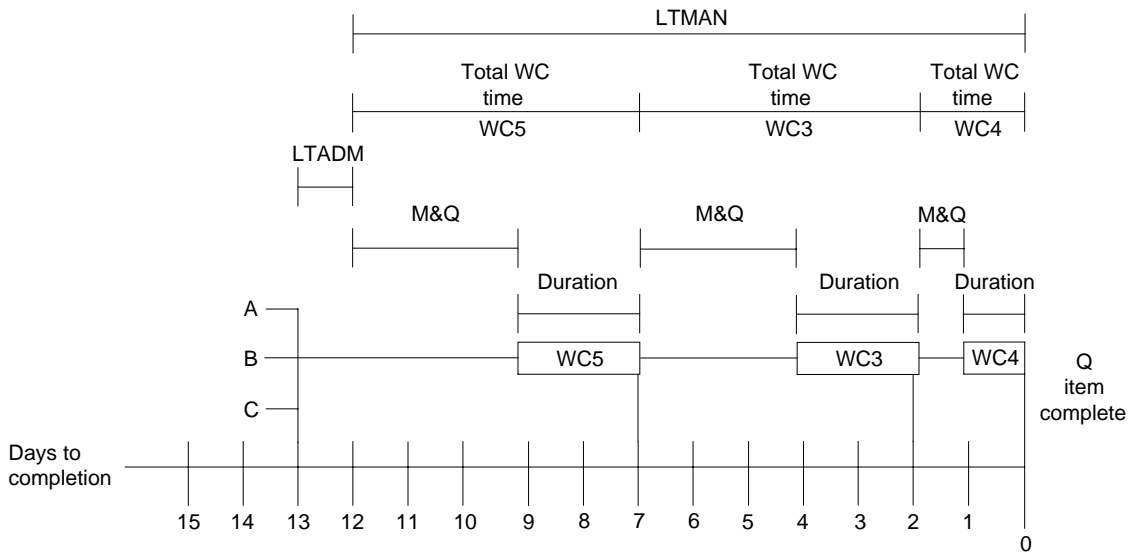

Figure 2-23. Offset for a work center

In Figure 2-23, the offset for work center WC5 is:

- 12 days time line of the item (Q)
- 5 days work center time for the work center
- 7 days offset for WC5

In Figure 2-23, the offset for work center WC3 is:

- 7 days remaining time line of the item (Q)
- 5 days work center time for the work center
- 2 days offset for WC3

If the work center is a critical resource, the system uses the calculated offset as the offset in the end item's resource profile.

Examples of offset calculations

The preceding discussions describe offset calculations when the total work center time for the item is equal to the item's LTMAN. The following examples show calculations when the total work center time for an item (item Q, an end item) is:

- Less than the LTMAN for Q
- Greater than the LTMAN for Q.

The discussions refer to the bill of material shown in Figure 2-24 for Q and to the lead time information (LTMAN and LTADM) listed for Q.

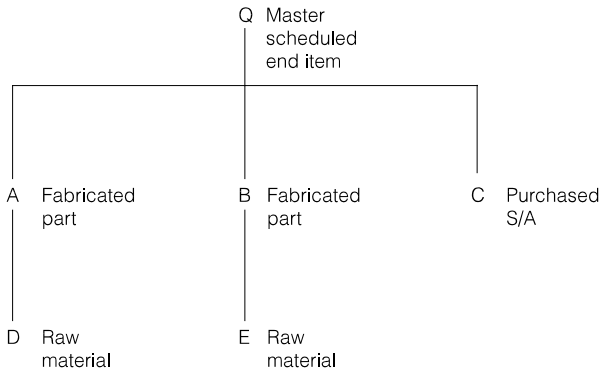

Figure 2-24. Sample bill of material

Lead time information for item Q:

LTMAN 12 days
LTADM 1 day
Total lead time 13 days

Example 1: Calculated work center time is greater than LTMAN of item

Figure 2-25. Calculated work center time is greater than **LTMAN** of item

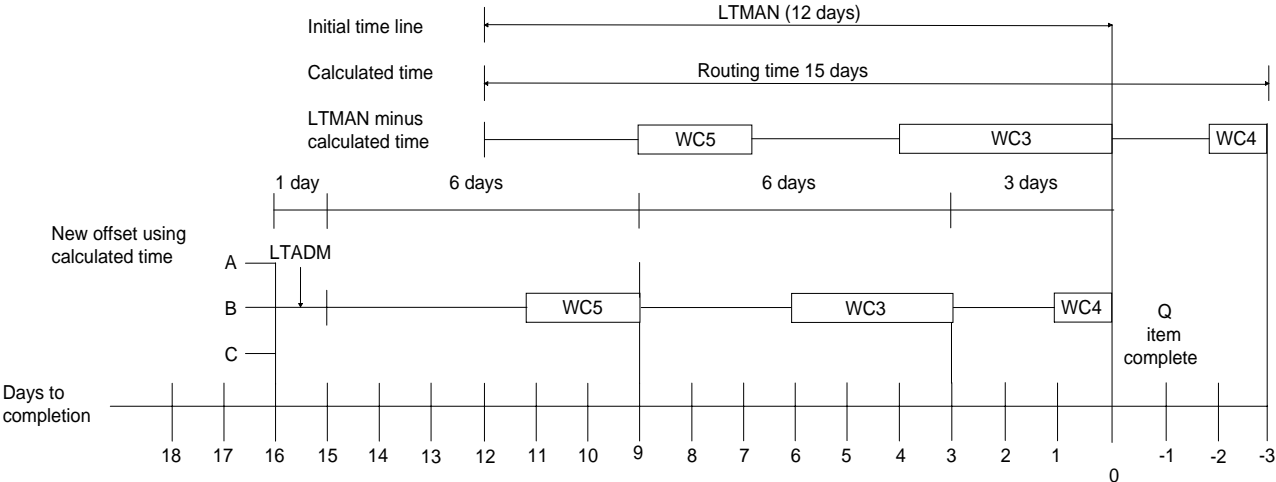

- The system sets a temporary time line (offset) equal to the item's LTMAN (12 days). Based on LTMAN, components A, B, and C are due 13 days before the item is to be complete (LTMAN + LTADM).
- The system calculates the work center time for all work centers in the routings for item Q, with the following results:

Work Center	Mfg. Time	Move Time	Queue Time	Work Ctr Time
WC5	3	1	2	6
WC3	4	1	1	6
WC4	1	1	1	3

- The total of the work center times for the routing (15 days) exceeds the LTMAN for Q. In this example, some work center offsets become negative, indicating that they are needed after the scheduled completion of the item. A negative offset for a generated profile indicates that the calculated lead times are greater than the Item Balance lead times. The user must reconcile lead times with the work center times to get dependable scheduling and resource planning results.
- The calculated offset for components A, B, and C is 16 days (15 + LTADM). Unless a component has a lead time adjustment, all components are needed 16 days before the item is to be complete.

Example 2: Calculated work center time is less than LTMAN of item

Figure 2-26. Calculated work center time less than LTMAN

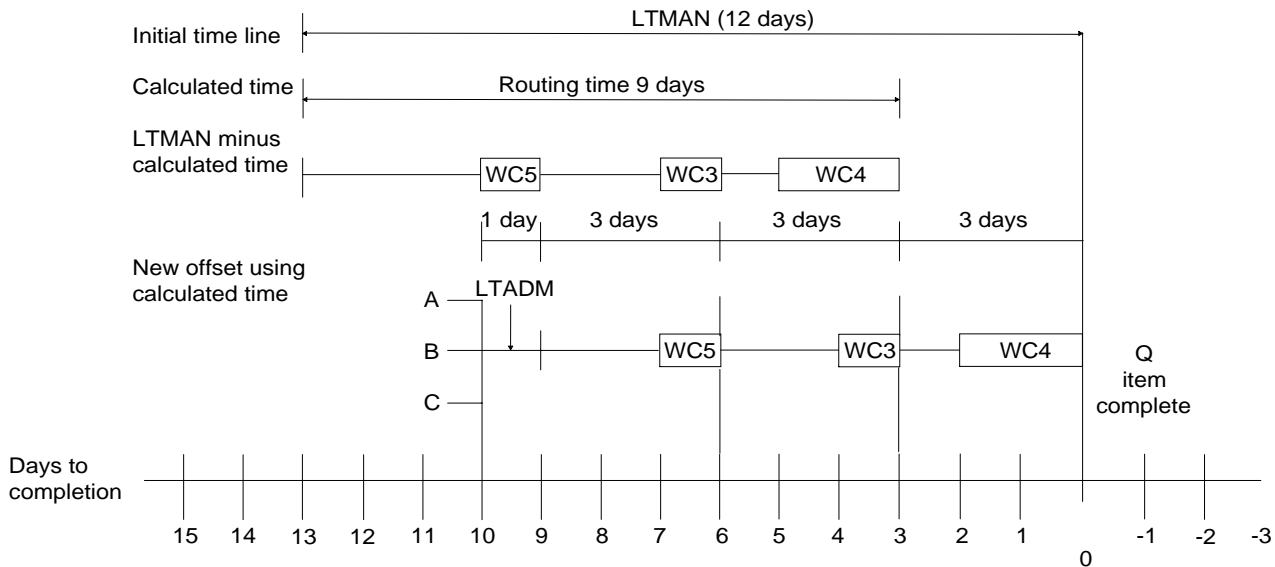

- The system sets a provisional time line (offset) equal to the item's LTMAN (12 days). Based on LTMAN, components A, B, and C are due 13 days before the item is to be complete (LTMAN + LTADM).
- The system calculates the total work center time for all work centers in the routings for item Q, with the following results:

Work Center	Mfg. Time	Move Time	Queue Time	Work Ctr Time
WC5	1	1	1	3
WC3	1	1	1	3
WC4	2	.4	.6	3

- The total of the work center times for the routing (9 days) is less than the LTMAN for Q. In this example, item Q is complete two days before it is due. The user must reconcile lead times with the work center times to get dependable scheduling and resource planning results.
- The calculated offset for components A, B, and C is 10 days (9 plus LTADM). Unless a component has a lead time adjustment, all components are needed 10 days before the item is to be complete.

Calculating the total time for a work center

To determine the total manufacturing time for each item, the system calculates the time needed to produce the extended quantity of the item at each work center in its routings.

Information used

The system uses the following information for the item and the work center:

- Prime load code (PLOAD). This code determines the time quantity (in hours) MPSP uses to calculate the manufacturing time for a work center. The system uses this quantity and the time basis code to get the time per item:
 - 1** RUNMC (machine run hours)
 - 2** SULHR/SUCSZ (setup labor hours divided by setup crew size = setup time)
 - 3** SULHR/SUCSZ + RUNMC (setup time plus machine hours)
 - 4** RUNLB (labor run hours)
 - 5** SULHR/SUCSZ + RUNLB (setup time plus labor hours)
- Time basis code (TBCOD). This code determines how the system interprets the work hours recorded for a work center. The system divides this rate into the work center hours to get the hours per unit for the work center.

H	Hours per lot
M	Minutes per piece
P	Pieces per hour
1	Hours per 10 units
2	Hours per 100 units
3	Hours per 1,000 units
4	Hours per 10,000 units
blank	Hours per unit
- Extended quantity of the item (the adjusted quantity-per of the item multiplied by the extended quantity of the parent).
- Current cumulative yield through previous operation (CYCOP) for the item. This number is a percentage that represents the quantity of the item expected to remain in the production process at the end of the preceding operation, compared to the quantity available at the start of the first operation.
- Current cumulative yield through all operations (CUMCY) for the item. This number is a percentage that represents the quantity of the item expected to remain at the end of all its operations, compared to the quantity that was available at the start of the first operation.
- Capacity of the work center (in hours per day). This number is an average based on a three-shifts day, as calculated for PC&C. MPSP uses this quantity to convert work center hours into manufacturing days.
- Standard efficiency (STDEF) for the work center.
- Move time (MOVTM) for the work center.
- Standard queue time (STDQT) for the work center.

Steps in calculating work center time

The calculation of work center time involves the following steps:

1. Add together the move time and standard queue time for the work center.
2. Calculate the time per unit for a standard lot or standard batch of the item. The result is hours per unit.
3. Calculate the hours required for the extended quantity of the item. This step multiplies the hours per unit times the extended quantity of the item. The result is hours required to produce the extended quantity.
4. Calculate the adjusted work center time based on work center yield rates. This step adjusts the calculated run time for this work center for an extended quantity of the item. The adjustment is based on current cumulative yield percentages for previous operations and for all operations for this item.

$$\text{adjusted work center time} = \frac{\text{Runtime} \times \text{CYCOP}}{\text{CUMCY}}$$

Where:

Runtime The previously calculated work center time for the extended quantity of this item

CYCOP Current cumulative yield through the previous operation

CUMCY Current cumulative yield through all operations for this item

5. Convert the hours into manufacturing days required. This step requires:
 - Calculating the capacity of the work center in hours per day, including an adjustment for the standard efficiency (STDEF) of the work center
 - Dividing the manufacturing hours by the number of hours per day available at the work center.

The result is manufacturing days required to produce the extended quantity of the item at that work center.

6. Add the manufacturing days to the move time and queue time. The result is the total time required for that work center in the routing.

An example of work center calculations. Figure 2-27 shows a simple bill of material with the work centers identified for each item:

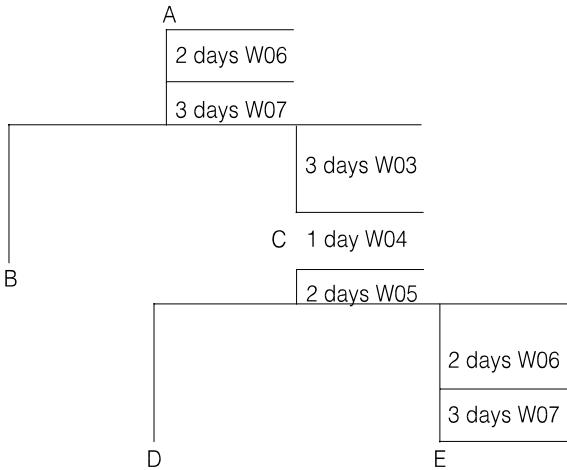

Figure 2-27. Bill of material with work centers

For component item C, the following information exists:

- Adjusted quantity per (QPACY) for parent item A = 2
- Lot size of parent A = 50 units
- Extended quantity of item C = 100 units (2 x 50)

For work center W03, the following information exists:

- Prime load code (PLOAD) = 1 (RUNMC)
- Time basis code (TBCOD) = 1 (hours per 10 units)
- Machine hours (RUNMC) = 1.35 hours
- Work center capacity = 7.6 hours per day*
- Standard efficiency (STDEF) = .95
- Cumulative yield through previous operations = .89
- Cumulative yield through all operations = .86
- Move time (MOVTM) = .4 days
- Standard queue time (STDQT) = .7 days

*Work center capacity calculation is explained later in this chapter.

Steps:

1. Add together the move time and queue time for the work center:
 $.4 \text{ days} + .7 \text{ days} = 1.1 \text{ days}$
2. Calculate the time per unit for a standard lot or standard batch of the item (RUNMC/TBCOD):
 $1.35 \text{ hours} / \text{hours per 10 units} = .135 \text{ hours per unit}$
3. Calculate the hours required for the extended quantity of the item (extended quantity of C = 100):
 $.135 \text{ hours per unit} \times 100 \text{ units} = 13.5 \text{ hours per extended quantity}$

4. Calculate the adjusted work center time based on work center yield rates (run hours x CYCOP z CUMCY):

$$(13.5 \text{ hours} \times .89) / .86 = 14.0 \text{ hours adjusted work center time}$$

5. Convert the hours into manufacturing days required:

$$14.0 \text{ hours} / 7.6 \text{ hours per day} = 1.9 \text{ days per extended quantity of C}$$

6. Add the manufacturing days to the move time and standard queue time for the work center:

$$1.9 \text{ days} + 1.1 \text{ days} = 3 \text{ days of work center time required for W03 in the routing for item C}$$

Calculating the work center capacity

The normal daily capacity for a work center is the sum of three shift capacities (in labor hours per day or machine hours per day) multiplied by the standard efficiency (STDEF) for the work center.

The basic capacity (WCAP) calculation is:

$$\text{WCAP} = [(\text{LEN1} \times \text{CAP1}) + (\text{LEN2} \times \text{CAP2}) + (\text{LEN3} \times \text{CAP3})]$$

where:

WCAP Work center capacity (in average daily machine or labor hours)

LEN1 Normal first shift length

CAP1 Men or machine hours normally available for the first shift

LEN2 Normal second shift length

CAP2 Men or machine hours normally available for the second shift

LEN3 Normal third shift length

CAP3 Men or machine hours normally available for the third shift

For the previous example, the calculation is:

$$\text{WCAP} = [(8 \text{ hours} \times 1 \text{ machine}) + (0 \text{ hours} \times 0 \text{ machines}) + (0 \text{ hours} \times 0 \text{ machines})] = 8 \text{ machine hours per normal day}$$

Then the system multiplies the basic daily capacity by the standard efficiency (STDEF) for the work center:

$$8.0 \text{ machine hours per day} \times .95 \text{ (STDEF)} = 7.6 \text{ hours of adjusted manufacturing time per day}$$

The adjusted capacity for this work center is 7.6 machine hours per day.

Calculating extended quantities

The system uses a calculated lot size called extended quantity for determining the quantity of each component needed to produce one standard lot or batch of the end item (or one composite lot of the production family).

Extended quantity for a master scheduled item

For a master scheduled item, the extended quantity of a component is the adjusted quantity-per (QPACY) of that component times the standard lot size or batch size of the end item. For a lower-level component, the extended quantity is the extended quantity of its parent times the QPACY of the component. Figure 2-28 shows the calculations:

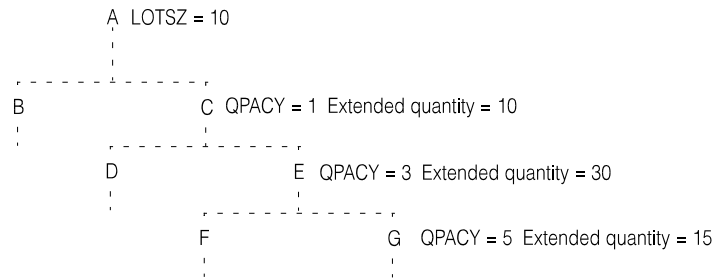

Figure 2-28. Calculating extended quantity for a master scheduled item

Extended quantity for a production family

For a production family, the extended quantity is based on the composite lot size of the family and a weighting factor calculated for each item in the family during aggregation. Total demand for a member item divided by the total demand for the family gives the percentage of demand that the item contributes to the family.

The system then calculates the extended quantity for each end item in the family. The calculation differs for items using lot size and items using standard batch quantity.

- For a lot-sized item, the system multiplies the family composite lot size by the item's demand percentage. In the example that follows, item A has a demand percentage of 30% (.30), and the family's lot size is 1000. The extended quantity of item A is 300.
- For a batch item, the system calculates the number of batches of the item needed per batch (or lot) of the family. The system divides the family lot size by the standard batch quantity of the item. Then it multiplies that result by the demand percentage for that item to get the extended quantity of the item needed for the current distribution of demand in the family.

For example, item B in Figure 2-29 is a batch item with standard batch quantity of ten.

1. The system divides the item's batch size into the family's batch (or lot) size of 1000. The result shows that it takes 100 batches of item B to produce one family composite lot.

2. The demand percentage for item B is 10% (.10), meaning that item B should represent only ten percent of the family's total production. The system multiplies batches per family (100) times the demand percentage for item B (.10). The resulting figure, 10 batches per family, is the extended quantity for item B. For every composite lot of the family, 10 batches of item B should be produced.

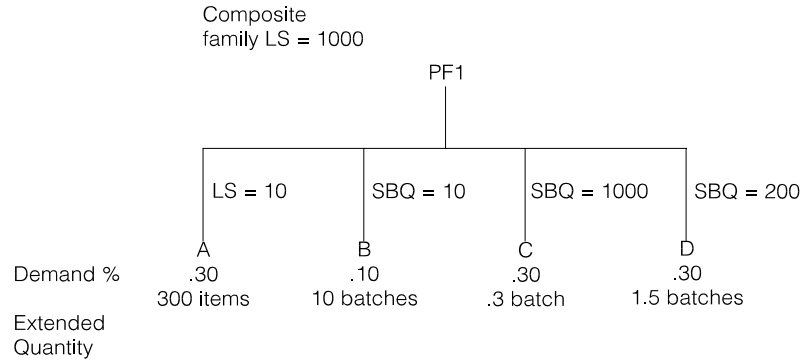

Figure 2-29. Calculating extended quantity for a production family

The calculation of extended quantity for components of the end items in the family is the same as for master scheduled items. See the preceding discussion.

Note: Each aggregation can change the demand percentages for the end items in a production family. Therefore, you should consider generating new resource profiles for production families after each aggregation in which item demand patterns change greatly.

Calculating resource values

The system calculates resource values in two contexts:

- For inclusion in the resource profile
- For inclusion in resource test results.

Values for resource profiles

When generating a resource profile, a different value calculation is used for a resource item than for a resource work center.

- For a resource item, the system multiplies the extended quantity of the item by the unit cost default (UCDEF) for the item.
- For a resource work center, the system does the following:
 1. Calculates the operation hours in terms of labor or machine hours based on the prime load code. See "Steps in calculating work center time" for more detail about the time calculation.

- Multiplies the number of hours by the Standard Run Labor Rate (SRLAB) or the Standard Run Machine Rate (SMACH) to get a cost (value) for the operation. The system uses the presence of a resource number in the **MACHINE RESOURCE NUMBER** or the **LABOR RESOURCE NUMBER** field of the Production Facility file record for the work center to determine the rate to use. If both fields have resource numbers, each is calculated separately. Each resource number gets its own usage record, though the offset is the same.

Note: MPSP does not include overhead when calculating the value for a critical resource.

Values for resource testing

When you test resources, the system calculates the value (and quantity) of each resource usage needed for an order or target. For each use, the system calculates the number of lots or batches in the order or target being tested. Then it uses that number as multiplier for the value (and quantity) in the profile record for each usage. That is, it multiplies the value in the resource profile record for that use (the value per standard lot or batch of the item or family) by the number of lots or batches in the order or target.

For example, the lot size of item A is 100. In the resource profile for item A, the quantity and value for each resource usage is for a lot of 100 items. In testing resources for an order for 50 of item A, the system divides the order quantity by A's lot size. The answer (.50) is a ratio of the size of the order to the lot size in the resource profile. The system multiplies the value (and quantity) of each resource usage by .50 to get the quantity and value of resource needed for that order.

Using the resource conversion factor

In MPSP, you can use MRP's price break conversion factor (PBCF) in the Item Planning (ITMPLN) file to:

- Define a critical resource in a unit other than the stocking unit of measure
- Define a critical resource that is actually a group of related items with different units of measure.

For a critical resource that is an item, MPSP uses the value that you enter in the price break conversion factor (PBCF) field to convert the extended quantities of the resources used into the unit of measure of the critical resource as you defined it in the Resource Master file. When you generate resource profiles, the system divides the extended quantity of the item by the conversion factor to get the quantity for the usage record.

Note: The calculation of value (extended quantity times the unit cost default for the item) does not change. It is based on the stocking unit of measure and the actual quantity used, regardless of the unit of measure in which it is expressed.

You can use the resource conversion factor (PBCF) to reduce the number of critical resources you must define to determine resource needs for a material that comes in different shapes and sizes. Without the conversion factor, you would have to assign a separate resource number to each form of the material and manually total the results to see the overall usage of the material. When you use the conversion factor, the resource uses the unit of measure you define for it in the Resource Master file; it does not use any price break literal that you may have assigned the item in MRP.

Grouping related resources with different units of measure

You can use the conversion factor to group critical resource items that have different stocking units of measure. For example, in Figure 2-30 the product structure shows that material A (aluminum) is used in four different forms:

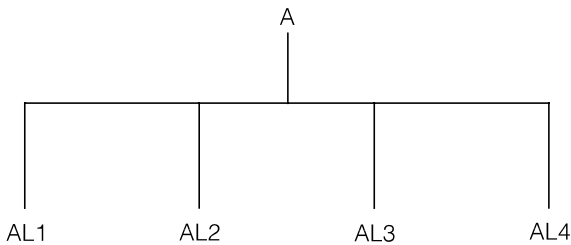

Item Master file

- AL1 Aluminum rod 1/4" diameter
- AL2 Aluminum tube 1/2" diameter
- AL3 Aluminum sheet 1/64" diameter
- AL4 Aluminum blanks 1/16" 2" x 2"

Figure 2-30. Uses of a common material

You could use the conversion factor to group and test those resources in several different combinations. Here are three:

Possible resource groupings

Alternative 1	Alternative 2	Alternative 3
100	100	800
200	200	800
300	800	800
400	800	800

Table 2-4. Possible resource groupings

- Alternative 1. You keep the identity of each type of usage. For this approach, you assign each item a different critical resource number and do not use the conversion factor.
- Alternative 2. You want to monitor items AL1 and AL2 separately, but you want the combined usage for items AL3 and AL4.

For this approach:

- Items AL1 and AL2 get separate critical resource numbers.
- Items AL3 and AL4 use the same critical resource number.
- You specify a conversion factor for AL3 or AL4 (or both) to convert their stocking unit of measure to the unit of measure of the combined critical resource. For example, you might want AL3 and AL4 expressed in a common unit of measure (pounds) different from their present units of measure (square feet and each).

- Alternative 3. All the related items use the same critical resource number. You specify conversion factors as necessary to convert all usages into the unit of the critical resource as you defined it in the Resource Master file. When you use this approach, a resource profile usage can include any or all of the four items that may appear in the bill of material of the item whose profile you are generating.

Every item with that resource number in its Item Plan record can contribute to usage figures for the resource.

Determining the conversion factor

The conversion factor you enter depends on how you choose to convert the units of measure. You can use the items in different stocking units of measure and provide a different conversion factor for each item. For example, alternatives 2 and 3 above would require a different conversion factor for each item you grouped as one resource.

This table shows how you can determine the conversion factor:

Unit	Stocking U/M	Weight unit of measure	Conversion factor (to attain pounds)
AL1	Feet	1 oz.	16.0000
AL2	Feet	4 oz.	4.0000
AL3	Sq. ft.	2 oz.	8.0000
AL4	Each	1 oz.	16.0000

The stocking units of measure (U/M) remain unchanged. In this example, expressing the quantity stocked in a unit of measure based on weight lets you see what conversion factor can change the original unit into the equivalent number of pounds.

Note: MRP uses the price break conversion factor (PBCF) only when the factor is used with combine codes 5 through 9. MRP uses this field when printing the Purchase Planning Report (AMM3B1). It uses the field to convert planned order quantities from a stocking unit of measure to an alternative purchase unit of measure.

Correcting lead times

While generating a resource profile, the system calculates a cumulative lead time (offset) for each component in the end item's bill of material. The system subtracts the calculated lead time from the manufacturing lead time (LTMAN) for the item in the Item Balance file and divides the difference by the manufacturing lead time to determine the percent of difference:

$$\% \text{ difference} = \frac{\text{LTMAN} - \text{calculated lead time}}{\text{LTMAN}}$$

If the difference equals or exceeds the percentage you specified (LEAD TIME DEVIATION PERCENT) when you started the generation, the system records both times for printing on the Resource Profile Exception Report (AML559).

The report prints the lead time values according to the minimum difference you specify. You can set the percentage high enough to ensure that any lead times printed on the report are seriously out of line with actual operation times.

Note: The system does not print lead time deviations for production families.

The lead times and lot sizes used in the profile must match the lead time and lot size information in your master files. The differences that show up on the Resource Profile Exception Report may be the result of using estimated lead times and lot sizes that you have not revised; they can also result from accumulated changes to routings and product structures over a period of time. If the lead times and lot sizes used for planning orders are different from the calculated values used for projecting your resource needs, your resource planning may be ineffective.

To ensure that the information you use for planning orders is consistent with the information the system uses for projecting resource needs, you may choose to generate resource profiles for all production families and master scheduled items you intend to test. You can use the resulting Exception Report (AML559) to identify and resolve inconsistencies before you begin testing resources.

Correcting lot or batch sizes

For each component item in the bill of material, the system calculates an extended quantity. The extended quantity of a component is the number or amount required for its parent (QPACY) multiplied by the quantity of the parent. This calculation tells you the number or amount needed at the component's level to produce one standard lot or one standard batch of the end item.

The system uses the extended quantity in calculating the use of critical resources for every item below the end item. The system also compares the extended quantity for the item to the item's standard lot size (LOTSZ) or standard batch quantity (SBQTY). If the extended quantity is greater, the system prints both values for the component item on the Resource Profile Exception Report (AML559). Large differences may indicate that you need to adjust lot sizes in the bill of material for that end item.

Note: When you generate a profile for a production family, the extended quantity of all components is based on a composite lot size for the family and on allowing a certain percentage of that lot size for each item in the family. See "Calculating extended quantities" on page 2-96 for more information about how the system calculates quantities for a family profile.

The system does not print lot size deviations for production families.

Testing resources

When you test resources for your family operating plans or your master production schedules, by individual planning warehouse or by a range of planning warehouses, the system uses the appropriate resource profiles to determine:

- The resources the family targets or master scheduled orders need
- The periods the resources are needed in
- How much of each resource is needed in each period
- What the value (costs) of the quantities needed is.

The system calculates this information only for items or families with resource profiles. The profiles can be generated or user-created. The accuracy and value of the results depends on the accuracy of the file information used to generate the

profiles and on the stability of your item, family, product structure, and routing information. Changes in family composition, product structures, or routings (for example, as the result of engineering changes) can make the resource testing information inaccurate and misleading.

In resource planning, you can test for family production target resource needs in each production planning period for up to three years. You can test for the needs of one production family or all production families.

In rough-cut capacity planning, you can test for master production schedule resource needs for as many weekly periods as you use in your master schedules. After that, the resource needs are summarized into period that match your production planning periods.

When to test resources

Resource projections are only as accurate as the profiles and production information used in the testing. You should consider testing resources again:

- After you generate profiles again or revise user-created profiles
- When you maintain family operating plans extensively
- When you maintain master production schedules extensively.

What happens in resource testing

During resource testing, the system uses the resource profile of a master scheduled item or production family to identify each time a critical resource would be used in producing each order or production target. For each time an order or target uses a critical resource, the system creates a usage record. The record includes the date of the need, the quantity, and the value. The system accumulates these records, sorts them, and records them in the Resource Test files.

When you look at resource requirements for family operating plans or master production schedules, you see the usage records accumulated by period. A supporting detail display lets you see the individual usage information.

The next figure shows the results of testing resources for a component item that is a critical resource. In this example, the master scheduled end item being ordered uses the component at three different production points, indicated by the three offsets. Resource testing shows how many components are needed and in which periods they are needed to supply all orders as planned. A number in parentheses (1) identifies the period of the order that is responsible for the resource need:

Resource profile information:

Quantity per = 50 per lot
Usage offsets: 3 days, 7 days, 16 days

Planning information for end item:

Standard lot size = 50
Fixed order quantity = 50
critical resource = component item

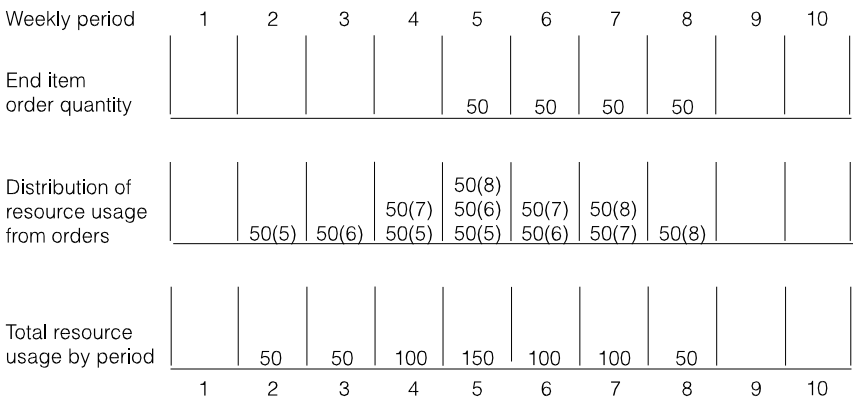

Figure 2-31. Resource testing for an item resource

Offsetting the usages for each order shows that for this item, a set order rate causes fluctuating demand for the resource.

Additional detail is also available to help you trace the sources of potential overloads. For resource requirements planning, you can see for any period the families and family production targets creating the need for the resource in that period. That information helps you select the targets you can change to reduce temporary resource overloads. For rough-cut capacity planning, you can see for any period a list of the master scheduled orders creating the need for the resource in that period, the quantity needed for each order (and its value), and the due date for the order.

Figure 2-32 shows how planning by production planning period affects the offsetting of resource needs. It also shows how you can detect resource overloads.

The item being tested is item Q, which has the following resource profile:

Offset	Resource	Quantity	Value
2	03000	6	90
14	03000	14	210
21	01000	6	120
23	01000	6	120
27	08000	1000	75

Figure 2-32 shows weekly planning for February and March, and monthly (production period) planning for later periods.

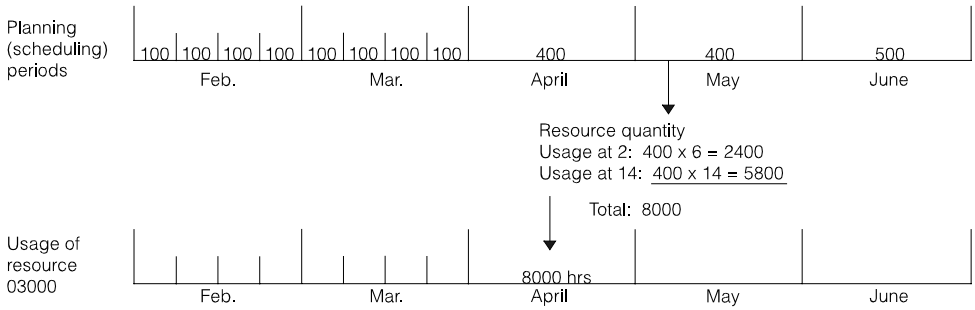

Figure 2-32. Resource testing by production planning periods

All quantities planned for May are due on May 1. Therefore, the offsets for resource 03000 place both of its uses in April. The total quantity required for the month exceeds the maximum quantity available (maximum quantity available equals the RATE/DAY in the Resource Master file for this resource multiplied by the number of work days in the period).

Note: In a normal manufacturing environment, the total usage of resource 03000 would result from its presence in many different routings for many different end and component items.

The basic resource testing process is the same for production families (testing family operating plans) and for master scheduled items (testing master production schedules). The following topics summarize the testing process and point out the major differences.

Testing production families (family operating plans)

The system uses the composite production family resource profile to identify the resources needed to meet the production targets in the family's operating plan. The family profile identifies

- When any component of any item in the family uses a critical resource
- The offset for that use from the end item's due date
- The quantity needed for one batch or lot of the family
- The cost of that quantity.

The extended quantity of each component is based on the proportional importance of its end item in the family, as calculated in the last aggregation. Therefore, the need for a resource that only one item in the family requires may differ significantly from test to test if demand for that item fluctuates.

For each target for the family, the system uses the family's composite profile to date back any resource use from the due date of the target. It accumulates the uses by resource, by period, and by target. The main display showing resource requirements (AML532) gives family totals per production planning period. However, you can use the Resource Requirements Detail display (AML533) to see the dates of the specific families and family targets contributing to that use.

To determine the resource quantity needed, the system divides each target by the family's composite lot size. The result is the number of lots of the family needed to meet the target. Then the system multiplies each use identified in the profile (calculated for one lot of the family) by the number of lots needed for that target, and records the usage quantity, the value, and the offset.

For example, if the family's lot size is 1,000, and the target for a period is 25,000, the number of lots needed to meet that target is 25. The system multiplies each resource use for that family by 25 to get the resource quantity needed.

Testing master scheduled items (master production schedules)

When you test master production schedules, the system calculates the resource need, value, and timing for each order for each master scheduled item with a profile. The resource profile identifies every use of the resource for any component of the master scheduled item. For each order, the system calculates the resources it requires, the quantity needed, the value, and the date by which it is needed. It dates back the usage starting from the due date of the order. It accumulates the usage information by period. When you test master schedule resources, the system uses current information about master scheduled orders. If open orders have pending changes, the system uses the changed values for its calculations.

To determine the quantity needed for each order, the system divides the order quantity by the lot or batch size of the master scheduled item. Then it multiplies each use (calculated per extended quantity) by the number of lots or batches needed to fulfill the order.

Note: To get accurate information about resource usage, you must have generated master schedules for all master scheduled items before you test resources. To ensure that you know the limits of the test results, the system shows you the lowest level at which master scheduled items exist and the lowest level at which you have generated master production schedules. If the two levels do not match, the testing information you get is incomplete.

On the main Resource Requirements Analysis display (AML532), you see the total use of a resource for all master scheduled items for each period. However, on the Resource Requirements Detail display (AML533), you can see within each period the item, the order number, and the order due date for each master scheduled order contributing to the usage total.

Available to promise (ATP)

MPSP's available to promise information tells you what quantities of an item remain uncommitted; that is, not needed to meet the current demand. The system calculates the quantities at the time of the inquiry, using current inventory, demand, and production information.

Available to promise in MPSP

In MPSP, available to promise assumes that no items are available for other uses as long as any demand within the horizon is not covered by on-hand inventory and projected receipts. When you calculate ATP, the system surveys demand to the end of the ATP horizon (defined below). If demand exceeds projected supply in any future period, the system reserves inventory to cover that demand before it shows any quantities as available.

For example, the demand for an item exceeds the supply on days 16 and 17. The demand is equal to supply on day 15, and demand is less than supply on days 13 and 14. The system subtracts the uncovered (unmet) demand on days 16 and 17 from the excess supply on day 14 before it shows an available quantity on day 14. If the excess supply on day 14 is not enough to cover the excess demand on days 16 and 17, the system subtracts the remaining demand from the excess on day 13. Therefore, even though supply exceeds demand on day 14, no items are available to promise because all of the excess on day 14 is needed to cover future demand.

Available to promise horizon

The system calculates ATP quantities by day for up to three years. The system stops calculating Available to Promise at the end of significant information or at the three year limit, whichever comes first. For each item, the system stops calculating on the last day containing one of the following kinds of information:

- The CMLT (cumulative material lead time) Time Fence.
- The Demand Time Fence.
- The last customer order.
- The last option backlog for an item.
- The last open order (manufacturing or purchasing).
- The last manufacturing allocation (if you are looking at a component item).
- The last firm planned order. Planned orders may appear within the horizon, but they do not affect the length of the horizon.

As information for an item changes, the length of the ATP horizon can also change.

Note: For an option item, the system uses the option item's Lead Time Adjustment to schedule its start date earlier than the due date of its parent.

Demand and supply quantities in ATP

To calculate demand for each day, the system adds:

- Customer orders for end items and component items, including intersite order requirements if ISL/MISL is installed.
- Option backlog for option items
- Manufacturing allocations for component items
- Generated demand from the Requirements file, if requested. The Requirements file is maintained through MRP.

If COM is installed and interfacing with MPSP, demand information comes from order entry files. If COM does not interface with MPSP, demand information comes from the Demand Interface file (DMDIFF) if it is found in the data base and manually updated. All allocation information comes from IM's manufacturing order files.

The system gets information about supply (receipts) from the following sources:

- Open manufacturing orders or schedules from the Manufacturing Order Master file.
- Open requisitions from the Purchasing Requisition file
- Open purchase orders from the Purchase Order Item Detail file.
- Purchase order blanket releases from the Purchase Order Blanket file.
- Firm planned orders and planned orders from the Planned Order file, which is maintained through MRP.
- Open intersite orders from the Transfer Order file, if ISL/MISL is installed.

Notes:

1. The system gets information about planned orders only if their due date is on or after the Demand Time Fence.
2. If you have maintained orders extensively since you last transferred master scheduled orders from an MRP run, the ATP information you see for master scheduled items may be different from the information in MPSP's files.

How MPSP calculates available to promise

The system calculates ATP quantities in three steps:

1. Calculate projected ending inventory (PEI) for each day. This quantity appears as Projected Inventory on displays AMVATP03 and AMVATP05.
2. Calculate the future unmet demand (FUD) for each day. This quantity appears as Future Unmet Demand on display AMVATP03.
3. Calculate ATP quantity for each day.

The calculation uses the following kinds of information:

Type of information	Description
Demand	The total customer backlog and manufacturing allocations due each day. It can also include generated demand from MRP, if requested.
Expected receipts/Supply	Total expected receipts each day including open schedules, requisitions, firm planned orders, planned orders, and intersite orders.
Projected ending inventory (PEI)	Beginning balance plus supply minus demand for each day.
Required starting inventory (RSI)	Demand minus supply plus the future unmet demand (FUD). This is the amount of inventory needed to meet a specific days demand plus any shortage in coverage against future demand. The calculation for RSI for a day is demand minus supply plus FUD. The RSI a day is the FUD of previous day.
Future unmet demand (FUD)	The amount of demand that is not covered by supply in future days. For a specific day, FUD is the RSI of the next day.
Available to promise (ATP)	Projected ending inventory (PEI) minus the future unmet demand (FUD) for each day.

This table shows a full set of ATP information and calculated results for a horizon of ten days. The item has a past due of 325 and no on-hand inventory.

On hand = 0

Type	Past Due	1	2	3	4	5	6	7	8	9	10
Demand	325	---	---	---	20	---	---	30	840	---	6
Supply		400	---	---	---	345	---	---	843	---	---
PEI	(-325)	75	75	75	55	400	400	370	373	373	367
RSI		<0	20	20	20	<0	33	33	3	6	6
FUD		20	20	20	0	33	33	3	6	6	0
ATP		55	55	55	55	367	367	367	367	367	367

Step 1: Calculate the projected ending inventory

This is the information needed to calculate the projected ending inventory. Projected ending inventory (PEI) = PEI for the previous day - demand for the day + supply for the day. The item has a past due of 325 and no on-hand inventory.

On hand = 0

Type	Past										
	Due	1	2	3	4	5	6	7	8	9	10
Demand	325	---	---	---	20	---	---	30	840	---	6
Supply		400	---	---	---	345	---	---	843	---	---
PEI	(-325)	75	75	75	55	400	400	370	373	373	367

In this example, the past due demand is 325 and on-hand inventory is zero. The overdue demand is added to demand for day 1. Therefore, the PEI for day 1 is:

```

0   on-hand inventory
-325 demand on day 1, including overdue demand
+400 supply on day 1
75  projected ending inventory for day 1

```

The PEI for day 2 is:

```

75  previous PEI
- 0  demand on day 2
+ 0  demand on day 2
75  projected ending inventory for day 2

```

Step 2: Calculate the FUD and RSI

This step determines how much inventory must be reserved to cover demand that is not met in the future (Future Unmet Demand). It requires calculating a required starting inventory (RSI) for each day as the basis for the future unmet demand (FUD). The calculation begins with the last day in the horizon. Calculating the FUD starting at the end of the horizon means that large demands in later days commits (reserves) inventory for earlier days until all demand is covered.

The calculation begins with the last day showing demand and works back to the earliest day. The required starting inventory for a day becomes the future unmet demand for the previous day. For example, in the following example, the RSI of 6 for day 10 becomes the FUD for day 9.

Note: The FUD for the last day is always zero since no demand exists past this day.

On hand = 0

	Past										
Type	due	1	2	3	4	5	6	7	8	9	10
Demand	325	---	---	---	20	---	---	30	840	---	6
Supply		400	---	---	---	345	---	---	843	---	---
RSI		<0	20	20	20	<0	33	33	3	6	6
FUD		20	20	20	0	33	33	3	6	6	0

The future unmet demand quantity for day 10 (the last day) is zero. The required starting inventory for day 10 is:

```

6 demand for day 10
- 0 supply for day 10
+ 0 future unmet demand
6

```

To satisfy demand for day 10, there should be a required starting inventory of six. The RSI of 6 becomes the future unmet demand for day 9.

The required starting inventory for day 9 is:

```

0 demand for day 9
- 0 supply for day 9
+ 6 future unmet demand
6 required starting inventory for day 9

```

The required starting inventory for day 8 is:

```

840 demand for day 8
- 843 supply for day 8
+ 6 future unmet demand
3 required starting inventory for day 8

```

Note: For day 5, the RSI is less than zero (supply exceeds demand and FUD). In this situation, the FUD for day 4 is shown as zero and not as a negative value.

Step 3: Calculating available to promise

The available to promise for a day is the projected ending inventory (PEI) for the day minus the future unmet demand (FUD) for the day.

The following figure shows the information needed to calculate the available to promise (ATP) quantities for the day.

On hand = 0

Type	Past due	1	2	3	4	5	6	7	8	9	10
PEI	325	75	75	75	55	400	400	370	373	373	367
FUD		20	20	20	0	33	33	3	6	6	0
ATP		55	55	55	55	367	367	367	367	367	367

Available to promise for day 6 is:

400	Projected ending inventory for day 6
-33	Future unmet demand for day 6
367	Available to promise for day 6

Negative available to promise quantities are shown as appropriate to indicate that your inventory plus current and planned production is not enough to meet known demand. Additional demand increases the imbalance.

The future period reserve for period 4 is zero because supply after period 4 is sufficient to meet all demand after period 4 and supply in period 5 is sufficient to meet demand in period 5.

Note: If excess demand occurs toward the end of the horizon, available to promise quantities are based on the last period with excess supply. Apparent excesses of demand (or supply) in later periods do not change the ATP in those periods because the system has considered all demand and supply quantities in later periods in calculating ATP and identifying the last period with uncommitted supply

Contents	Index	Exit
--------------------------	-----------------------	----------------------

Chapter 3. Production Planning

When you select option 1 on the Main Menu (AMLM00), the Production Planning secondary menu (AMLM10) appears.

Option 1. Aggregate to Production Families (AMLM10)	3-4
Option 2. Display and Maintain Family Operating Plans (AMLM10)	3-8
Option 3. Test Family Operating Plan Resources (AMLM10)	3-26
Option 4. Display Resource Requirements (AMLM10)	3-31
Option 5. Display and Maintain Item Trial Plans (AMLM10)	3-40
Option 6. Replace Family Base Plans (AMLM10)	3-51
Option 7. Replace Item Production Plans (AMLM10)	3-54
Option 8. Family Plan Inquiries (AMLM10)	3-57
Option 9. Family Operating Plan Report (AMLM10)	3-80
Option 10. Display and Maintain Production Families (AMLM10)	3-83

Use options 1 through 9 to set up or revise family-level and item-level production plans as a demand source for master scheduling. Use option 10 to set up and revise production families. Even if you are not using other production planning options, you can use option 10 to set up production families so you can review master production schedules by production family.

Note: If EPDM is activated, a master file search is available to allow you to search for items in the Item Revision Master file.

```

AML10                Master Production Schedule Planning          *****
                    Production Planning

Type option or command; press Enter.

    1. Aggregate to Production Families
    2. Display and Maintain Family Operating Plans
    3. Test Family Operating Plan Resources
    4. Display Resource Requirements
    5. Display and Maintain Item Trial Plans
    6. Replace Family Base Plans
    7. Replace Item Production Plans
    8. Family Plan Inquiries
    9. Family Operating Plan Report
   10. Display and Maintain Production Families

==> _____

F3=Exit      F4=Prompt   F9=Retrieve   F10=Actions
F11=Job status  F12=Return  F22=Messages

```

Option 1. Aggregate to Production Families. Use this option to summarize your current inventory, demand, and production planning information at the item level into family-level totals. These totals help you set or change your family-level production targets and inventory goals. Functional options controlling whether the aggregation will include the adjusted on-hand, held inventory, and/or safety stock can be set by the production family or by individual items within a production family. Aggregation begins from the menu option. After you select a planning warehouse range in which to perform the aggregation a confirmation message appears before the system submits the job to the job queue.

Note: This is a batch process and may require considerable time. You should schedule aggregation to minimize your waiting time and to avoid delaying other batch jobs.

Option 2. Display and Maintain Family Operating Plans. Use this option to review and change, by planning warehouse, the production targets and inventory goals for your production families. You can see, by period, family-level totals about current demand, projected inventory, and possible production rates.

Option 3. Test Family Operating Plan Resources. Use this option to calculate, by planning warehouse, the quantity and value of the critical resources needed to meet your family operating plan production targets. This process is also called resource requirements planning. You can test resources for one family or for all families.

Option 4. Display Resource Requirements. Use this option to review, by period, and planning warehouse, the quantity and value of a critical resource needed to meet your family operating plan production targets. A selection display lets you specify the resource to review. You can also see details about the families that are contributing to the use of that resource in a specific period.

Option 5. Display and Maintain Item Trial Plans. Use this option to compare your present item production plans, by planning warehouse, with current item trial plans and with the family's production targets by period. Using this option, you can adjust your existing item production levels to bring them into balance with new family targets and changes in item net demand.

Option 6. Replace Family Base Plans. Use this option to accept the current operating plans, by planning warehouse, for one or all families as new base plans. You can track your success in meeting production and inventory goals over time by comparing current operating plans to the base plans.

Option 7. Replace Item Production Plans. Use this option to adopt your adjusted item trial plans, by planning warehouse, as the new item production plans for one or all production families. The new item production plans are the demand source used for master scheduling those items.

Option 8. Family Plan Inquiries. Use this option to show, by planning warehouse, the base plan and operating plan for a family so that you can compare planned levels to actual and projected levels of sales, production, or inventory. You can also compare the family-level production targets in the operating plan to the aggregated item production plans, item trial plans, and master production schedules for all items in the family.

Option 9. Family Operating Plan Report. Use this option to print, by range of planning warehouses, the Family Operating Plan Report containing the family operating plan for one or more families for 12 consecutive periods. You can optionally include the item production plans for all items in each family, and you can have the quantities printed in costs or units.

Option 10. Display and Maintain Production Families. Use this option to review and change, by planning warehouse, the master scheduled items assigned to a production family. Use this option also to create or delete a production family, and to specify whether aggregation should consider adjusted on-hand, held inventory, and/or safety stock. You should review and revise your production families before you aggregate.

Option 1. Aggregate to Production Families (AMLM10)

Use this option to accumulate, by selected range of planning warehouses, your current inventory, demand, and production planning information at the item level into family-level totals. These totals help you set or change your family-level production and inventory goals. Functional options controlling whether the aggregation will include the adjusted on-hand, held inventory, and/or safety stock can be set by the production family or by individual items within a production family, using option 10 on this menu.

Note: You must be authorized to the proper level of security in the warehouses you select.

Aggregation produces the Aggregation Error List (AML340) report, which prints two kinds of messages:

- Messages identifying file retrieval errors that the system found during aggregation
- Messages identifying problems with family or item information.

What information you need:

Planning warehouses in which you want to run aggregation.

What reports are printed:

Aggregation Error List (AML340).

What forms you need: None.

The basic steps to perform the aggregation follow each display.

AMV3HL—Aggregate to Production Families

Use this display to select in which planning warehouses the aggregation will be performed. You can select a single planning warehouse, or a range of planning warehouses. For each warehouse that falls in the range selected, separate jobs are initiated and separate reports are printed.

Note: You must be authorized to the proper level of security in the warehouses you select.

This display appears when you select option1 on menu AMLM10.

For the **From** and **To** ranges on this display, the value you type in the **To** field must be greater than or equal to the value you type in the **From** field when both fields are used. The range begins with and includes the value you type in the **From** field; it ends with and includes the value you type in the **To** field.

If you type a value in the **From** field only, the system ends the range with the highest value for that field. If you type a value in the **To** field only, the system begins the range with the lowest value for that field. If you want to select records by a single value instead of a range, use that value in both the **From** and **To** fields.



What to do

- To request the aggregation, select a range of planning warehouses and press **Enter**. The confirmation screen AML3A0 appears.
- To cancel the session, use **F24**. Menu AMLM10 appears again.

Function keys

F1=Help shows information about this display. Pressing **F1** or pressing the **help** key shows you the same information.

F5=Refresh resets the display as it was before you typed in any values.

Contents	Index	Exit
--------------------------	-----------------------	----------------------

F24=Cancel ends processing and any data you typed is ignored. The Production Planning menu (AML10) appears again.

Fields

[?] appears next to a field name in the following field definitions to identify a field from which you can begin a master file search.

Planning warehouse limits.

From warehouse/To warehouse [?]: The range of warehouses to use for aggregation.

AMV3A0—Aggregate to Production Families (Confirm)

Use this display to confirm the planning warehouses selected for aggregation and to begin the job.

This display appears when you select warehouses and press **Enter** on display AMV3HL.

```
DATE *****          AGGREGATE TO PRODUCTION FAMILIES          AMV3A0

                          PLANNING WAREHOUSE    ***

DO YOU WANT TO CONTINUE WITH THIS AGGREGATION RUN (Y/N)?  n

                                                                    F24 END OF JOB
```

What to do

- To perform the aggregation, confirm the selected warehouse, and type **Y**. The aggregation is submitted to the job queue. When you press **Enter**, the next warehouse in the range of warehouses appears.
- To cancel the session without performing the aggregation, type **N** or use **F24**. Menu AMLM10 appears again.

Function keys

F24=Cancel ends processing and any data you typed is ignored. The Production Planning menu (AMLM10) appears again.

Fields

PLANNING WAREHOUSE. The first and succeeding warehouse in the range of warehouses you selected on display AMV3HL.

DO YOU WANT TO CONTINUE WITH THIS AGGREGATION?. Type **Y** to submit the aggregation to the job queue. Type **N** to cancel the request.

Contents	Index	Exit
--------------------------	-----------------------	----------------------

Option 2. Display and Maintain Family Operating Plans (AMLM10)

Use this option to review and maintain the production targets and inventory goals for your production families. You can see by period, family-level totals about current demand, projected inventory, and possible production rates.

What information you need:

The number of the production family whose operating plan you want to review or change and the planning warehouse in which it resides.

What reports are printed: None.

What forms you need: None.

The basic steps to display and maintain family operating plans follow each display.

AML201—Display/Maintain Family Operating Plans Selection

Use this display to begin reviewing and changing the current operating plans for one or more production families in a planning warehouse. You also can choose whether you want to see the plan shown in costs or units.

Note: You must be authorized to the proper level of security in the warehouses you select.

This display appears when you select option 2 on menu AMLM10.

Note: Family operating plans represent the latest aggregation of inventory, forecasts, and customer backlog. Before reviewing or changing family operating plans, be sure you do all of the following:

- Complete any necessary changes to the composition of production families. To do this, choose option 10, Display and Maintain Production Families, on the Production Planning menu (AMLM10).
- Load the Demand Interface (DMDIFF) file, if Forecasting is installed and interfacing
- Place current forecasts into the Demand Interface (DMDIFF) file, if Forecasting is not installed and interfacing
- Place customer orders into the Demand Interface (DMDIFF) file, if Customer Order Management is not installed and interfacing
- Choose option 1, Aggregate to Production Families, on the Production Planning menu (AMLM10).

If you have completed a recent aggregation, you do not need to aggregate before reviewing or changing the family operating plans.

```
DATE *****          DISPLAY/MAINTAIN FAMILY OPERATING PLANS          AML201 MB
                               SELECTION

PLANNING WAREHOUSE                aA3
ENTER STARTING FAMILY NUMBER      aaaaaaaaaaaaaA15

DISPLAY PLAN IN COSTS OR UNITS <C/U>  A

IF OVERFLOW OCCURS,
CHANGE SIGNIFICANCE FOR THIS SESSION <K/M> A

                                     F24 END OF JOB
```

What to do

- To review or change the operating plan for a production family, type in the required information and press **Enter**. Go to display AML202.
- To end the session, use **F24**.

Function keys

F24=END OF JOB ends processing and causes the Production Planning menu (AMLM10) to appear.

Fields

[?] appears next to a field name in the following field definitions to identify a field from which you can begin a master file search.

PLANNING WAREHOUSE [?]. Type the identifier of the warehouse you want to use.

ENTER STARTING FAMILY NUMBER [?]. Type the number of the production family whose operating plan you want to review or change first. Other production families appear in sequential order when you use **F06 NEXT FAMILY** on the Display/Maintain Family Operating Plans display (AML202).

DISPLAY PLAN IN COSTS OR UNITS <C/U>. Type **C** (costs) for the operating plan to appear in costs or **U** (units) for the plan to appear in units. The value you selected when you answered the questionnaire appears on the display. If you do not type anything in this field, the system uses that value.

IF OVERFLOW OCCURS, CHANGE SIGNIFICANCE FOR THIS SESSION <K/M>. Type in the one-letter code that identifies a new quantity significance to use for this production family for this session. The quantity significance determines how many digits are shown or printed in quantity fields on production planning displays and reports. The codes are:

blank System shows or prints all digits (the full quantity).

K System does not show or print the last three digits (000). Multiply by 1,000 for the actual quantity.

M System does not show or print the last six digits (000,000). Multiply by 1,000,000 for the actual quantity.

For example, if the quantity significance for a production family is (000), the quantity 2,795 is actually 2,795,000. This method of shortening quantities makes them easier to read and adjusts very large quantities that exceed the length of the fields in which they appear.

Note: This field does not show a quantity significance code initially. If you leave the field blank when you enter a new production family number, the significance assigned to the family on display AML361 during file maintenance appears in the SIGNIFICANCE field on displays AML202, AML203, and AML204. When you return to display AML201 from displays AML202, AML203, or AML204, the code for that significance value appears in this field.

The primary purpose of this field is to allow you to recover if message W AM-8571 OVERFLOW HAS OCCURRED ON THIS DISPLAY appears on display AML202. You can then return to this display and temporarily change the significance for this

Contents	Index	Exit
--------------------------	-----------------------	----------------------

session by entering a new significance code (K or M). In this way, you can look at the quantities in fields where overflow has occurred. The value you type in remains until one of the following happens:

- You change the quantity significance code again.
- You select a different family to review.
- You end the job (**F24**).

Note: To change the quantity significance for a family permanently, use production family maintenance (option 10 on menu AMLM10). For more information about quantity significance, see “AML361—Display/Maintain Production Families”.

AML202—Display/Maintain Family Operating Plans

Use this display to show the operating plan for the production family you selected so that you can review or make changes to the production targets in one or more periods. Each family's operating plan appears with the current production, sales and inventory information, and the maximum or desired production levels you can reach by period.

This display appears when you:

- Type in a valid production family number and press **Enter** on the Display/Maintain Family Operating Plans Selection display (AML201)
- Use **F03 RESUME INQ** (Inquiry) on the Family Operating Plan Detail display (AML203) or the Daily Rates display (AML204).

```

DATE **/**/**          DISPLAY/MAINTAIN FAMILY OPERATING PLANS          AML202 **
FAMILY *****          WEIGHTED COST **,**,** **,**,**          UNITS
DESC *****          ON HAND *,**,**          SIGNIFICANCE *****
PERIOD  PRODUCTION  BLENDED  PROJECTED  FAMILY  CUMULATIVE  MAX
DATE    TARGET      DEMAND   INVENTORY NET DMD   CHECK      TARGET
**/**/**  *,**,**  *,**,**  *,**,**  *,**,**  *,**,**  *,**,**

*****
PAGING DATE nnnnnn  F06 NEXT FAMILY  F09 CALC TARGETS  F19 RETURN TO SELECT
                   F07 COST/UNITS  F10 MAINTAIN TARGET
                   F08 DSP DETAIL   F18 REFRESH DISPLAY  F24 END OF JOB

ENTER STARTING PERIOD nnnnnn          ENDING INVENTORY nnnnnn
ENTER ENDING PERIOD  nnnnnn          F03 RESUME INQUIRY

ENTER PERIOD nnnnnn          TARGET nnnnnn          F03 RESUME INQUIRY

```

On this display, you can:

- Review the operating plan (in costs or units) for a family
- Enter a new production target for a specific period
- Calculate production targets for a range of periods rather than one specific period.

When you type in new production targets, the system recalculates projected inventory and checks to make sure the new targets meet the family's net demand. The body of the display is updated, but if you decide to not update the files with the

Contents	Index	Exit
--------------------------	-----------------------	----------------------

new values, you can use **F18 REFRESH DISPLAY** to see the display as it was before you changed it.

Note: When you complete making changes to the production targets, you can use option 3, Test Family Operating Plan Resources, on the Production Planning menu (AMLM10) to make sure you have the capacity to produce the quantities in the operating plan.

What to do

- To review the operating plan in future production periods for this family, press **Enter**. More periods exist if CONTINUED appears in the lower left of the display.
- To review the operating plan for this family starting at a specific date, type the date into the **PAGING DATE** field and press **Enter**.
- To review additional supply and demand information in the operating plan for this family, use **F04** and go to display AML203.
- To review the operating plan for the next sequential production family, use **F06**.
Note: When you use **F06** and the system reaches the last family in the file, the Display/Maintain Family Operating Plans Selection display (AML201) appears.
- To change the method in which the operating plan is shown (costs or units), use **F07**.
- To review the aggregated inventory status and how your production targets compare to the latest aggregated item net demand and adjustments (item trial plans), use **F08**. The Family Operating Plan Detail display (AML203) will appear.
- To calculate a first-cut production plan for a family for a range of periods, use **F09**.
 - To calculate a first-cut production plan for a range of periods and update the **PRODUCTION TARGET**, **PROJECTED INVENTORY**, and **CUMULATIVE CHECK** fields, type in the required information, and press **Enter**.
 - To start the inquiry again without performing any calculations, use **F03**.
- To change the production target for a specific period, use **F10**, type in the required information and press **Enter**. The system updates the **PRODUCTION TARGET**, **PROJECTED INVENTORY**, and **CUMULATIVE CHECK** fields in the body of the display.
 - To start the inquiry again, use **F03**.
- To see the display as it was before you changed anything in the fields, use **F18**.
- To review the operating plan for a different family, use **F19** and go to display AML201.
- To end the session, use **F24** and go to menu AMLM10.

Function keys

F03 RESUME INQUIRY causes display AML202 to appear again in Inquiry mode and ends any maintenance action you have started. This function key does not appear when the display is in Inquiry mode.

F06 NEXT FAMILY causes the operating plan for the next sequential family to appear without returning to the Selection display (AML201). This function key updates the files with any changes you made to the production targets.

F07 COSTS/UNITS lets you review the operating plan in costs or units. Use this function key to switch between costs and units.

F08 DSP DETAIL (Display Detail) causes the Family Operating Plan Detail display (AML203) to appear. This display shows you the aggregated inventory status and how your production targets compare to the latest aggregated item net demand and adjustments (item trial plans).

F09 CALC TARGETS (Calculate Targets) causes the following entry fields to appear at the bottom of the display so that you can create a first-cut production plan for the family for a range of periods. This technique lets you see the production calculated and distributed evenly over the number of required working days in each period.

ENTER STARTING PERIOD. Type in the beginning date of the period in which you want the calculation of the production targets to begin.

ENTER ENDING PERIOD. Type in the beginning date of the period in which you want the calculation of the production targets to stop.

ENDING INVENTORY. Type in the quantity you want in inventory at the end of the period you specified in the **ENTER ENDING PERIOD** field.

Note: After you type in the information and press Enter, the system performs the calculations. Display AML202 appears again with the **PRODUCTION TARGET**, **PROJECTED INVENTORY**, and **CUMULATIVE CHECK** fields recalculated. You can review these fields, then do one of the following:

- Use **F09** to type in different information for a first-cut production plan for a range of periods
- Use **F10** to change a production target in a specific period
- Use **F18** to see the display as it was before you made any changes
- Use **F06**, **F19**, or **F24** to update the files with your changes.

F10 MAINTAIN TARGET causes entry fields to appear at the bottom of the display so that you can change the production target for a single period.

ENTER PERIOD. Type in the beginning date of the period in which you want to change the production target.

TARGET. Type in the new production target quantity for the period whose date you typed in the previous field.

Note: After you change the production target for a single period using **F10 MAINTAIN TARGET**, press **Enter** to type in another period date and production quantity. Pressing **Enter** also changes the body of the display to show the results of your entries. The system recalculates production target, projected inventory, and cumulative check.

F18 REFRESH DISPLAY causes display AML202 to appear as it was before you made any changes. This lets you simulate changes to the operating plan for a family and start over if the changes are not satisfactory.

F19 RETURN TO SELECT causes the Selection display (AML201) to appear.

F24 END OF JOB causes the Production Planning menu (AMLM10) to appear. This function key updates the files with any changes you made to the production targets.

Fields

Display AML202 has three sections:

- The heading, which shows reference information about the family
- The body, which shows the family's operating plan by period
- The lower part of the display, which shows function keys and application and system messages.

The following fields appear in the heading:

FAMILY (PFNBR). The number of the family whose operating plan appears in the body of the display.

WEIGHTED COST. A calculated average cost per item for the items in this family. The system uses this cost to convert quantities from units to costs for production planning displays and reports. The cost is based on each item's standard unit cost (STDUC), if available, or on the item's unit cost default (UCDEF).

COSTS or UNITS. The method in which the operating plan is shown, based on the value you selected when you answered the Questionnaire. The word COSTS or UNITS appears. You can use **F07 COSTS/UNITS** to switch between costs or units.

DESC (Description) (ITDSC). The description of the family whose operating plan you want to review or change.

ON HAND (FMOHD). The total quantity of items in this family in inventory at the beginning of the first period in the operating plan including aggregated safety stock and aggregated held inventory.

SIGNIFICANCE (Quantity Significance) (PFSIG). The number of field positions (digits) the quantity fields are shortened on production planning displays and reports.

You see one of the following in this field:

- | | |
|-----------|--|
| () | System shows all digits (the full quantity). |
| (000) | System does not show the last three digits (000). Multiply by 1,000 for the actual quantity. |
| (000,000) | System does not show the last six digits (000,000). Multiply by 1,000,000 for the actual quantity. |

For example, if the quantity significance for a production family is (000), the quantity 2,795 is actually 2,795,000.

The following fields make up the body of the display. Family operating plans appear in chronological order by PERIOD DATE. If CONTINUED appears at the lower left of the display, pressing **Enter** shows you the next set of periods. You can also use the **PAGING DATE** field to see an operating plan beginning at the date you specify.

Contents	Index	Exit
--------------------------	-----------------------	----------------------

The fields shown in the body of the display are for information only; you cannot change them by typing over them. To change production targets or ending inventory, you must use the function keys at the bottom of the display.

Note: When you create or change production targets, press **Enter** after each change to see the changes on the display. Pressing **Enter** updates the display but does not update the files.

PERIOD DATE. The beginning dates of the production planning periods.

PRODUCTION TARGET. The total quantity of items in this family that management wants to produce in this period. Management sets the production targets based on actual demand (customer orders) or expected sales (forecasts) and the desired level of inventory. When you use the appropriate function key to change the production targets, this field appears again with the new targets. If the production target is greater than the maximum target for the period, the production target is highlighted.

BLENDED DEMAND. The result of aggregating the blended demand of each item in the family. Blended demand is the greater of forecast or customer orders for each period.

PROJECTED INVENTORY. The quantity of items in this family expected in inventory at the end of a period, if you reach sales and production plans. Projected inventory is equal to the inventory available at the beginning of the period plus the production target minus blended demand. This field is highlighted when it is less than safety stock.

FAMILY NET DMD (Demand). The total quantity of items in this family that must be produced in a period according to the last aggregation. Family net demand is the total of the item net demands for all items in that family. Held inventory is not considered when this value is calculated. For more information about how the system calculates item net demand, see Chapter 2, "Managing Master Production Schedule Planning".

CUMULATIVE CHECK. The result of the system checking to make sure that the family's cumulative production targets are greater than or equal to the family's cumulative net demand. The system calculates cumulative check by subtracting the cumulative family net demand from the cumulative production targets. When you change production targets, the system recalculates cumulative check. This field is highlighted when it is negative.

Note: A negative cumulative check amount in a period indicates that production is not meeting net demand for all the items in the family. To correct this condition, you can increase the production target in or before the period to meet family net demand.

MAX TARGET (Maximum Target). The maximum or desired quantity of items in the family that can be produced in this period. Maximum target is calculated using the working days in each period multiplied by the family's rate/day.

CONTINUED/END. If CONTINUED appears at the lower left of the display, pressing **Enter** shows you the operating plan for the next set of periods. If END appears at the lower left, pressing **Enter** shows you the first periods of the operating plan again.

ENTER STARTING PERIOD. See "Function keys."

ENTER ENDING PERIOD. See "Function keys."

ENTER ENDING INVENTORY. See "Function keys."

ENTER PERIOD. See "Function keys."

TARGET. See "Function keys."

PAGING DATE. If you type a date into this field at the lower left of the display, pressing **Enter** shows you the operating plan beginning with the date you type. If the date you type is not a production period beginning date, the system shows you the operating plan for the next period.

Note: If the paging date you type is after the last production period, this display (AML202) appears with the detail lines blank. If this occurs, press **Enter**. The operating plan appears again, beginning with the first production period.

AML203—Family Operating Plan Detail

Use this display to show the latest aggregated item trial plans for you to compare to the family production targets in each period.

This display appears when you:

- Use **F08 DSP DETAIL** on the Display/Maintain Family Operating Plans display (AML202)
- Use **F08 PREV SCREEN** on the Daily Rates display (AML204).

On this display, you can check to be sure the aggregated item trial plans (the latest net demand for items in the family plus aggregated adjustments for items in the family) equal or come close to the production target for the family. In periods where this is not true, you can either adjust the item trial plans for the family or change the production targets. The information on this display can help you decide in which periods you need to change item information.

If you look at this display immediately after the last aggregation and before you change production targets, the AGGREGATED ITEM NET DMD reflects the most current changes. With this information, you may decide that production targets need to be increased or decreased to meet aggregated item net demand. You can also change item trial plans to stay within the targets established for the family.

Note: Use option 5, Display and Maintain Item Trial Plans, on the Production Planning menu (AMLM10) to change item trial plans for the family.

If conditions have changed significantly since the last aggregation, item-level current demand and inventory may not be reflected in production plans yet. If so, you may need to aggregate before using the aggregated item trial plans shown on this display. To do that, select option 1, Aggregate to Production Families, on the Production Planning menu (AMLM10).

```

DATE **/**/**          FAMILY OPERATING PLAN DETAIL          AML203 **
FAMILY *****          UNITS
DESC *****          SIGNIFICANCE *****
ON HAND *,***,***    SAFETY *,***,***    HELD *,***,***    BALANCE *,***,***
PERIOD  PRODUCTION    FAMILY    ----- AGGREGATED -----
DATE    TARGET      BUILD +/-  TRIAL PLAN  ITEM NET DMD  ADJUSTMENT
**/**/**  *,***,***    *,***,***    *,***,***    *,***,***    *,***,***

*****
PAGING DATE nnnnnn

F03 RESUME INQ
F08 DAILY RATES
F24 END OF JOB
    
```

What to do

- To review the operating plan in future periods for this family, press **Enter**. More periods exist if CONTINUED appears in the lower left of the display.
- To review the operating plan for this family starting at a specific date, type the date into the **PAGING DATE** field and press **Enter**.
- To return to the Display/Maintain Family Operating Plans display (AML202), use **F03** and go to display AML202.
- To review the production targets and aggregated trial plans converted to a cost per day or quantity per day format, use **F08** and go to Daily Rates display (AML204).
- To review the production targets and aggregated trial plans converted to a cost per day or quantity per day format, use **F04**. Go to display AML204.
- To end the session, use **F24**.

Function keys

F03 RESUME INQ (Resume Inquiry) causes the Display/Maintain Family Operating Plan display (AML202) to appear.

F08 DAILY RATES causes the Daily Rates display (AML204) to appear. From this display, you can review the production targets and aggregated trial plans converted to a cost per day or quantity per day format.

F24 END OF JOB causes the Production Planning menu (AMLM10) to appear. This function key updates the files with any changes you made to the production targets.

Fields

Display AML203 has three sections:

- The heading, which shows reference information about the family
- The body, which shows aggregated item information in the operating plan for the family
- The lower part of the display, which shows function keys and application and system messages.

The following fields appear in the heading:

FAMILY (PFNBR). The number of the family whose operating plan appears in the body of the display.

COSTS or UNITS. The method in which the operating plan is shown. The word COSTS or UNITS appears.

DESC (Description) (ITDSC). The description of the family whose operating plan you are reviewing.

SIGNIFICANCE (Quantity Significance) (PFSIG). The number of field positions (digits) the quantity fields are shortened on production planning displays and reports.

You see one of the following in this field:

- () System shows all digits (the full quantity).
- (000) System does not show the last three digits (000). Multiply by 1,000 for the actual quantity.
- (000,000) System does not show the last six digits (000,000). Multiply by 1,000,000 for the actual quantity.

For example, if the quantity significance for a production family is (000), the quantity 2,795 is actually 2,795,000.

ON HAND (FMOHD). The total quantity of items in this family in inventory at the beginning of the first period in the operating plan.

SAFETY (FMSAF). The sum of all item safety stock quantities in the family. They were added during the last aggregation.

HELD (FMHLD). The total quantity of items in this family's inventory set aside for future planned shipments.

BALANCE. The inventory quantity for this family that is not assigned. The production family balance equals family on-hand inventory minus family safety stock minus family held inventory.

The following fields make up the body of the display. Family operating plans appear in chronological order by period date. Press **Enter** to see the next set of periods, or use the **PAGING DATE** field to see an operating plan beginning at the date you specify.

The fields shown in the body of the display are for information only; you cannot change them by typing over them.

PERIOD DATE. The beginning dates of the production planning periods.

PRODUCTION TARGET. The total quantity of items in this family that management wants to produce in this period. Management sets the production targets based on actual demand (customer orders) or expected sales (forecasts) and the desired level of inventory.

FAMILY BUILD +/-. The amount that the family's total item trial plans must be increased or decreased to meet the production target for the family. A minus sign indicates that the family's aggregated item trial plan for the period needs to be decreased by the amount shown. The absence of a sign indicates a positive amount by which you need to increase the family's total aggregated item trial plan for the period. The system calculates the family build amount by subtracting the aggregated trial plans from the production target.

Ideally, this field should contain zeros. If the last operating plan was developed so that this field did contain zeros, then any amount that appears now is the result of changes in the family's net demand.

AGGREGATED TRIAL PLAN. The result of the system adding the net demand for all items in the family (**AGGREGATED ITEM NET DMD** field) to the adjustments (**AGGREGATED ADJUSTMENT** field) for all items in the family.

AGGREGATED ITEM NET DMD (Demand). The sum of the current item net demands for the family. Held inventory is considered when this value is calculated.

AGGREGATED ADJUSTMENT. The sum of the current item adjustments for the family.

CONTINUED/END. If CONTINUED appears at the lower left of the display, pressing **Enter** shows you the operating plan for the next set of periods. If END appears at the lower left, pressing **Enter** shows you the first periods of the operating plan again.

PAGING DATE. If you type a date into this field at the lower left of the display, pressing **Enter** shows you the operating plan beginning with the date you type. If the date you type is not a production period beginning date, the system shows you the operating plan for the next period.

Note: If the paging date you type is after the last production period, this display (AML203) appears with the detail lines blank. If this occurs, press **Enter**. The operating plan appears again, beginning with the first production period.

AML204—Daily Rates

Use this display to review the production quantities that should be produced daily in each period so that you can meet the production target for the period. The family's production targets and aggregated item trial plans are converted into a daily production quantity or a daily cost by period, based on your choice on the Display/Maintain Family Operating Plans Selection display (AML201).

This display appears when you use **F08 DAILY RATES** on the Family Operating Plan Detail display (AML203).

On this display, you can:

- Review the production targets for the family converted to a TARGET RATE PER DAY for each period. The target rate is the family quantity you must produce daily so that you can meet the family production target for the period.
- Review the aggregated item trial plans converted to a TRIAL RATE PER DAY for each period. The trial rate is the total quantity of items in this family you must produce daily if you were to meet the trial production plan.
- Compare the TARGET RATE PER DAY for each period to the maximum or desired RATE/DAY for the family in the heading of the display.
- Compare the TRIAL RATE PER DAY for each period to the maximum RATE/DAY for the family in the heading of the display
- Compare the TRIAL RATE PER DAY to the TARGET RATE PER DAY.

```

DATE **/**/**                DAILY RATES                AML204 **
FAMILY *****                UNITS
DESC *****                *****
PERIOD      PRODUCTION    AGGREGATED    DAYS IN    SIGNIFICANCE *****
DATE        TARGET        TRIAL PLAN    PERIOD    PER DAY    TRIAL RATE
**/**/**   *,***,**   *,***,**   **        *,***,**   *,***,**

*****
PAGING DATE nnnnnn                F03 RESUME INQ
                                      F08 PREV SCREEN
                                      F24 END OF JOB

```

What to do

- To review the operating plan in future periods for this family, press **Enter**. More periods exist if CONTINUED appears in the lower left of the display.
- To review the operating plan for this family starting at a specific date, type the date into the **PAGING DATE** field and press **Enter**.
- To return to the Display/Maintain Family Operating Plans display (AML202), use **F03**.
- To return to the Family Operating Plan Detail display (AML203), use **F08**.
- To return to the Family Operating Plan Detail display (AML203), use **F04** and go to display AML203.
- To end the session, use **F24**.

Function keys

F03 RESUME INQ (Resume Inquiry) causes the Display/Maintain Family Operating Plans display (AML202) to appear.

F08 PREV SCREEN (Previous Display) causes the Family Operating Plan Detail display (AML203) to appear.

F24 END OF JOB causes the Production Planning menu (AMLM10) to appear. This function key updates the files with any changes you made to the production targets.

Fields

Display AML204 has three sections:

- The heading, which shows reference information about the family
- The body, which shows the family production targets and aggregated item trial plans converted to the quantities you should produce per day by period
- The lower part of the display, which shows function keys and application and system messages.

The following fields appear in the heading:

FAMILY (PFNBR). The number of the family whose operating plan and aggregated trial plans appear in the body of the display.

COSTS or UNITS. The method in which the operating plan is shown. The word COSTS or UNITS appears.

DESC (Description) (ITDSC). The description of the family whose operating plan and aggregated item trial plans you are reviewing.

RATE/DAY (PFCAP). The maximum or desired quantity you can produce for this family in one day.

SIGNIFICANCE (Quantity Significance) (PFSIG). The number of field positions (digits) the quantity fields are shortened on production planning displays and reports.

You see one of the following in this field:

- () System shows all digits (the full quantity).
- (000) System does not show the last three digits (000). Multiply by 1,000 for the actual quantity.
- (000,000) System does not show the last six digits (000,000). Multiply by 1,000,000 for the actual quantity.

For example, if the quantity significance for a production family is (000), the quantity 2,795 is actually 2,795,000.

The following fields make up the body of the display. Family production targets appear in chronological order by period date. Press **Enter** to see the next set of periods, or use the **PAGING DATE** field to see the plan beginning at the date you specify.

The fields shown in the body of the display are for information only; you cannot change them by typing over them.

PERIOD DATE. The beginning dates of the production planning periods.

PRODUCTION TARGET. The total quantity of items in this family that management wants to produce in this period. Management sets the production targets based on actual demand (customer orders) or expected sales (forecasts) and the desired level of inventory.

AGGREGATED TRIAL PLAN. The result of the system adding the net demand for all items in the family to the adjustments for all items in the family.

DAYS IN PERIOD. The number of working days in the planning period, calculated by the system. The system uses this number to calculate the family quantities you must produce daily in each period.

TARGET RATE PER DAY. The quantity you should produce for this family per day in each period so that you can meet the production target for the family. The target rate per day is equal to the production target quantity for the family divided by the number of working days in the planning period.

Note: If the target rate per day is greater than the maximum or desired rate/day quantity in the heading of the display, the TARGET RATE PER DAY quantity is highlighted.

TRIAL RATE PER DAY. The total quantity of items in this family you must produce daily if you were to meet the trial production plan. The trial rate per day is equal to the trial production plan quantity divided by the number of working days in the period.

Note: If the trial rate per day is greater than the maximum or desired rate/day quantity in the heading of the display, the TRIAL RATE PER DAY quantity is highlighted.

Contents	Index	Exit
--------------------------	-----------------------	----------------------

CONTINUED/END. If CONTINUED appears at the lower left of the display, pressing **Enter** shows you the operating plan for the next set of periods. If END appears at the lower left, pressing **Enter** shows you the first periods of the operating plan again.

PAGING DATE. If you type a date into this field at the lower left of the display, pressing **Enter** shows you the operating plan beginning with the date you type. If the date you type is not a production period beginning date, the system shows you the operating plan for the next period.

Note: If the paging date you type is after the last production period, this display (AML204) appears with all the detail lines blank. If this occurs, press **Enter**. The operating plan appears again, beginning with the first production period.

Contents	Index	Exit
--------------------------	-----------------------	----------------------

Option 3. Test Family Operating Plan Resources (AML10)

Use this option to calculate the resources needed to meet the production targets for one or all production families. The select display appears for you to identify a single family for testing. If you do not enter a number, the system tests resources for all production families that have resource profiles.

What information you need:

The number of the production family if you want to calculate the resource needs of only one family and the planning warehouse in which it resides.

What reports are printed: None.

What forms you need: None.

The basic steps to test family operating plan resources follow each display.

AMV3HR—Test Family Operating Plan Resources

Use this display to select in which planning warehouses the family operating plan tests will be performed. You can select a single planning warehouse, or a range of planning warehouses. For each warehouse that falls in the range selected, separate jobs are initiated and separate reports are printed.

Note: You must be authorized to the proper level of security in the warehouses you select.

This display appears when you select option 3 on menu AMLM10.

For the **From** and **To** ranges on this display, the value you type in the **To** field must be greater than or equal to the value you type in the **From** field when both fields are used. The range begins with and includes the value you type in the **From** field; it ends with and includes the value you type in the **To** field.

If you type a value in the **From** field only, the system ends the range with the highest value for that field. If you type a value in the **To** field only, the system begins the range with the lowest value for that field. If you want to select records by a single value instead of a range, use that value in both the **From** and **To** fields.

```
AMV3HR                Test Family Operating Plan Resources

Planning warehouse limits
From warehouse . . . . . aA3
To warehouse  . . . . . aA3

F1=Help              F5=Refresh   F24=Cancel
```

What to do

- To proceed, select a range of planning warehouses and press **Enter**. Display AML541 appears.
- To cancel the session, use **F24**. Menu AMLM10 appears again.

Function keys

F1=Help shows information about this display. Pressing **F1** or pressing the **help** key shows you the same information.

F5=Refresh resets the display as it was before you typed in any values.

Contents	Index	Exit
--------------------------	-----------------------	----------------------

F24=Cancel ends processing and any data you typed is ignored. The Production Planning menu (AMLM10) appears again.

Fields

[?] appears next to a field name in the following field definitions to identify a field from which you can begin a master file search.

Planning warehouse limits.

From warehouse/To warehouse [?]: The range of warehouses to use for testing resources.

AML541—Test Family Operating Plan Resources Selection

Use this display to confirm your warehouse selection and to select one production family for which to calculate the resources needed to meet family production targets. If you do not enter a production family number, the system tests resources for all production families that have resource profiles in the planning warehouse selected.

This display appears when you select planning warehouses and press **Enter** on display AMV3HR. The first warehouse in the range is displayed. When you press **Enter**, the next warehouse in the range is displayed. When no more warehouses remain in the range you selected, menu AMLM10 appears again.

This display begins the process of testing resources for production families. The system calculates the quantities and values of specific critical resources needed to meet the production targets set in current family operating plans. After the calculations are complete, you can review the usage of a specific resource using option 4, Display Resource Requirements, on the Production Planning menu (AMLM10).

Note: To ensure accurate results, be sure that all production families to be tested have resource profiles. When you are testing a single family, error messages inform you if the family has no profile or no operating plan. If you are testing all families in the selected warehouses, the system omits any family that lacks a profile and continues processing. It does not cancel the test or generate messages.

```
DATE *****      TEST FAMILY OPERATING PLAN RESOURCES      AML541 MB
                        SELECTION
PLANNING WAREHOUSE          ***
ENTER PRODUCTION FAMILY NUMBER (OPTIONAL)  aaaaaaaaaaaaA15

F24 END OF JOB
```

What to do

- To calculate the production resources needed for one family, type in the production family number and press **Enter**. An explanatory message and **F09 RUN JOB NOW** appear on the selection display. Do one of the following:
 - To run the resource test interactively at your work station, use **F09** and go to menu AMLM10.
 - To run the resource test as a batch job, press **Enter**. The system submits the job to the job queue.

- To end the session without calculating (testing) production resource needs, use **F24**.
- To calculate the combined production resources needed for all families in the planning warehouse displayed, leave the field blank and press **Enter**. The system submits the job to the job queue.

Note: To see the results of this resource test, wait until the system completes the job. Then use option 4, Display Resource Requirements, on the Production Planning menu (AMLM10).

Function keys

F09 RUN JOB NOW starts the resource test for a single production family as an interactive job from your work station. You cannot begin another task from your work station until the test is complete. When the job ends, the Production Planning menu (AMLM10) appears.

F24 END OF JOB ends processing and causes the Production Planning menu (AMLM10) to appear. The system ignores any information you typed on the display.

Fields

[\[?\]](#) appears next to a field name in the following field definitions to identify a field from which you can begin a master file search.

PLANNING WAREHOUSE. The identifier of the first and succeeding warehouses you selected on display AMV3HR.

ENTER PRODUCTION FAMILY NUMBER (OPTIONAL) [?]. Type in the number of the production family whose resource needs you want to calculate. If you leave this field blank, the system calculates (tests) the production resources needed to meet the family operating plan production targets for all families in the selected planning warehouses.

If you type in a valid production family number, you can test its resource needs interactively from your work station. After you type in the number, **F09 RUN JOB NOW** appears with a message explaining your choices. Use **F09** to run the job interactively. Press **Enter** to submit the job to the job queue.

Note: You can use interactive testing to check the resources needed to meet new or changed production targets for a family. You can verify that the new family operating plan fits resource constraints before you begin maintaining plans for other families.

Option 4. Display Resource Requirements (AMLM10)

Use this option to review information about the quantities and value of a critical resource needed to meet the production targets in your family operating plan. You can also identify the production families and production targets that require a critical resource during a specific period.

What information you need:

The number of the critical resource whose uses you want to review and the planning warehouse in which it resides.

Note: The information on the Resource Requirements displays (AML531, AML532, and AML533) comes from the last time you tested family operating plan resources. A field below the display title shows you that the resource requirements you see come from family operating plans.

What reports are printed: None.

What forms you need: None.

The basic steps to display resource requirements follow each display.

AML531—Resource Requirements Selection

Use this display to identify your planning warehouse selection and to select the critical resource for which you want to see usage requirements and other information by period.

Note: You must be authorized to the proper level of security in the warehouse you select.

This display appears when you:

- Select option 4 on menu AMLM10 or AMLM20.
- Use **F06** on the Resource Requirements Analysis display (AML532) and no more resources exist in the sequence you started
- Use **F19** on the Resource Requirements Analysis display (AML532).

From this display, you can go to a series of displays that show you for each period how much of the resource is needed, the value of that quantity, and how much of the resource is expected to be available in that period. You can also see details about the families that use the resource in a specific period.

Note: The same series of Resource Requirements displays (AML531, AML532, and AML533) appears when you select option 4 on the Production Planning menu (AMLM10) or option 4 on the Master Schedule Planning menu (AMLM20). However, the information shown depends on the menu option you used.

The field below the display title shows you whether the resource requirements you see come from family operating plans or from master scheduled orders. To see the resource requirements for family operating plans, select option 4 on the Production Planning menu (AMLM10). To see the resource requirements for master scheduled orders, select option 4 on the Master Schedule Planning menu (AMLM20).

You can review a specific resource, all resources, or only the resources with exception conditions. When you review all resources or resources with exception conditions, the resources appear in numeric sequence, beginning with the resource number you type in.

```
DATE **/**/**          RESOURCE REQUIREMENTS          AML531 MB
                        SELECTION
                        *****
PLANNING WAREHOUSE          aA3
ENTER STARTING RESOURCE NUMBER  aaaA5
DISPLAY EXCEPTION RESOURCES ONLY <Y/N>  A

                                F24 END OF JOB
```

What to do

- To review information about the quantities and the periods when a resource is used, type in the information requested and press **Enter**. Go to display AML532.
- To end the session, use **F24**.

Function keys

F24 END OF JOB ends processing and causes the Production Planning menu (AMLM10) to appear. The system ignores any information you typed on the display.

Fields

[?] appears next to a field name in the following field definitions to identify a field from which you can begin a master file search.

*********. The kind of plans that generated these resource needs: operating plans or master schedule.

PLANNING WAREHOUSE [?]. Type the identifier of the warehouse you want to use.

ENTER STARTING RESOURCE NUMBER [?]. Required. Type in the number identifying the first resource in this warehouse for which you want to see the production requirements by period. You can use **F06 NEXT RESOURCE** on display AML532 to review resources sequentially. Each time you press **F06**, you see resource information for the next higher resource number.

Note: You must have tested your family operating plans (option 3 on the Production Planning menu, AMLM10) before the system can show you any resource requirements. The information you see is the result of the last time you tested family operating plan resources.

Contents	Index	Exit
--------------------------	-----------------------	----------------------

DISPLAY EXCEPTION RESOURCES ONLY <Y/N>. Type in **Y** (to see only the resources that use more than the available quantity in one or more periods. Type in **N** to see all resources in sequence. To see a specific resource that does not have an exception condition, you must type N in this field.

AML532—Resource Requirements Analysis

Use this display to show information by period about a critical resource needed to meet the production targets set in your family operating plans.

This display appears when you type in a valid resource number and press Enter on the Resource Requirements Selection display (AML531) or when you use F03 on the Resource Requirements Detail display (AML533).

On this display, you can:

- See the quantity and value of this resource needed for each period, along with the quantity of the resource expected to be available in that period
- See the cumulative difference between resource quantities needed and resource quantities available
- Select a specific period to see details about the families that use the resource in that period.

The system uses the following information to calculate resource usage:

- Resource profiles for the families, based on lead times and other information in the Item Balance, Production Facility, Product Structure, and Routing files
- Current family operating plans
- Resource definitions from the Resource Master file.

If any of that information is incorrect or out of date, the resource calculations are inaccurate.

The number of periods of information you see depends on the length of your family plans. Periods for family operating plans continue to the end of the plans, giving you information for longer-range resource planning at the family level.

Note: The information you see on this display is the result of the last time you tested family operating plan resources.

```
DATE **/**/**          RESOURCE REQUIREMENTS ANALYSIS          AML532 **
RESOURCE NUMBER ***** PRODUCTION PLAN                      U/M ***
DESCRIPTION *****
PERIOD                RESOURCE          RESOURCE          RESOURCE          CUMULATIVE
DATE                VALUE            QUANTITY          AVAILABLE          VARIANCE
**/**/**            *,**,* ,**,* .**   **,* ,**,*      **,* ,**,*      **,* ,**,* ,**

ENTER DATE FOR DETAIL nnnnnn          F06 NEXT RESOURCE  F19 RETURN TO SELECT
*****                                  F24 END OF JOB
```

What to do

- To review more uses of this resource, press **Enter**. More uses exist if CONTINUED appears in the lower left of the display.
- To review the uses of the next critical resource in the sequence you selected, use **F06**.
- To review the uses of another specific resource, or to begin another sequence of resources, use **F19** and go to display AML531.
- To see details about the production families and production targets using this resource in a specific period, type the date of the period you want to review into the field at the bottom of the display and press **Enter**. Go to display AML533.
- To end the session, use **F24**.

Function keys

F06 NEXT RESOURCE causes this display (AML532) to appear again with information about the next resource in the sequence you are using. If you are at the last resource in the sequence you are using (all resources or only resources with exceptions), **F06** causes the Resource Requirements Selection display (AML531) to appear so you can begin another sequence or start with another resource number.

F19 RETURN TO SELECT causes the Resource Requirements Selection display (AML531) to appear. The system ignores any information you typed on the display.

F24 END OF JOB ends processing and causes the Production Planning menu (AMLM10) to appear. The system ignores any information you typed on the display.

Fields

RESOURCE NUMBER (RMRSC). The number identifying the critical resource whose requirements you are reviewing. You typed this number on the Resource Requirements Selection display (AML531).

OPERATING PLAN. The kind of plans that generated these resource needs.

U/M (Unit of measure) (RMUOM). A code for the unit of measure used in measuring this resource. This code is taken from the Resource Master file.

DESCRIPTION (RMDES). A description that helps to identify the resource. This description is taken from the Resource Master file.

RESOURCE/DAY (RMMAX). The quantity of this resource available for use in one work day. The quantity may reflect average use, a maximum rate of replenishment, or a maximum capacity. This quantity is taken from the Resource Master file.

If CONTINUED appears in the lower left of the display, more periods exist than can appear at one time. Press **Enter** to see the next set of periods.

PERIOD DATE. The beginning date of a production planning period in which this resource is needed. However, the system does not show usage for periods or the part of a period before the system date (today's date): that usage is considered as already expended.

Note: If any quantity or value is too large to appear in the field, the system shows all 9s for that field.

RESOURCE VALUE. The total value (cost) of the resource quantity needed during the period.

RESOURCE QUANTITY. The total quantity of this resource needed during this period. This quantity is the total of all uses of this resource in family member production in the period. If the quantity needed for the period exceeds the quantity available, this field is highlighted.

RESOURCE AVAILABLE. The total quantity of this resource that can be available during this period. This quantity is the resource per day (RMMAX) multiplied by the number of work days in this period.

CUMULATIVE VARIANCE. The cumulative difference, by period, between the total resource quantity available and the total quantity needed. If the cumulative need exceeds the cumulative quantity available, this field becomes negative.

ENTER DATE FOR DETAIL. Type in the beginning date of the period for which you want to see detailed information and press **Enter**. If there are no errors, the Resource Requirement Detail display (AML533) appears with a list of production targets using the resource during that period, the resource quantity for each use, and other supporting information. If there are errors, display AML532 appears again with error messages. The fields in error are highlighted. Correct the errors and press **Enter** to continue processing.

CONTINUED/END. If CONTINUED appears at the lower left of the display and you do not type a date into **ENTER DATE FOR DETAIL**, pressing **Enter** shows you information about resource needs in the next set of periods. If END appears, pressing **Enter** shows you the first periods again.

Function keys

F03 RESUME INQ (Resume Inquiry) causes the Resource Requirements Analysis display (AML532) to appear. The periods shown are the same as when you last saw the display.

F12 ADDL FIELDS (Additional Fields) causes the item description to display or not display.

Fields

RESOURCE NUMBER (RMRSC). The number identifying the critical resource whose requirements you are reviewing. You typed this number on the Selection display (AML531).

OPERATING PLAN. The kind of plans that generated these resource needs.

U/M (Unit of Measure) (RMUOM). A code for the unit of measure used in measuring this resource. This code is taken from the Resource Master file.

DESC (Description) (RMDES). A description that helps to identify the resource. This description is taken from the Resource Master file.

RSC/DAY (Resource per Day) (RMMAX). The quantity of this resource available for use in one work day. The quantity may reflect average use, a maximum rate of replenishment, or a maximum capacity. This quantity is taken from the Resource Master file.

PERIOD DATE. The beginning date of the period for which this display shows detailed resource usage. You typed this date into **ENTER DATE FOR DETAIL** on display AML532. The entries appear in family number sequence and by target date within the family.

If CONTINUED appears in the lower left of the display, more family operating plan details exist than can appear at one time. Press **Enter** to see the next set of details.

ITEM NUMBER (ITNBR). The Item Master file number of a production family that uses this resource.

Description (ITDSC). A description of the production family.

Note: If any quantity or value is too large to appear in the field, the system shows all 9s for that field.

RESOURCE QUANTITY. The quantity of this resource required to meet the family production target for this period.

RESOURCE VALUE. The cost of the resource quantity needed for this family production target.

ORDER DATE (RTORG). The date of the production target that generated this use.

CONTINUED/END. If CONTINUED appears at the lower left of the display, pressing **Enter** shows you the next set of targets that need this resource within this period. If END appears, pressing **Enter** shows you the first targets again.

Option 5. Display and Maintain Item Trial Plans (AMLM10)

Use this option to:

- Review the item production plans and item trial plans for a production family.
- Review the item production plans and item trial plans for a specific item (without entering a family number).
- Enter production adjustments (increase or decrease production) for an item by period to meet family production targets.
- Change the current level of held inventory.

What information you need:

- The number of the production family whose item trial plans you want to review or maintain
- The item number if you want to review the trial plans for a specific item without typing in a family number
- The number of the planning warehouse in which the production family/ item number you want to use resides.

What reports are printed: None.

What forms you need: None.

The basic steps to display and maintain item trial plans follow each display.

AML230—Display/Maintain Item Trial Plans Family Selection

Use this display to select your planning warehouse and to select a production family whose item trial plans you want to review or change. You can also select a specific item within that family.

Note: You must be authorized to the proper level of security in the warehouse you select.

This display appears when you select option 5 on menu ALMLM10 or when you use **F01 RESTART-FAMILY** on the Display/Maintain Item Trial Plans Item Selection display (AML231) or the Display/Maintain Item Trial Plans display (AML232).

```
DATE  **/**/**      DISPLAY/MAINTAIN ITEM TRIAL PLANS      AML230  **
                        FAMILY SELECTION

      PLANNING WAREHOUSE          aA3
      ENTER STARTING FAMILY NUMBER  aaaaaaaaaaaaA15
      ENTER STARTING ITEM NUMBER    aaaaaaaaaaaaA15

                                           F02 RESTART ITEM
                                           F08 NEXT FAMILY
                                           F24 END OF JOB
```

What to do

- To review or maintain the item trial plans for a production family, type in the planning warehouse and production family number and press **Enter**. Go to display AML232.
- To review or maintain the item trial plans for a specific item within the production family, type in the production family number and the item number, and press **Enter**. Go to display AML232.
- To review and maintain the trial plans for a specific item, use **F02** and go to display AML231.
- To review or maintain the item trial plans for the next sequential family, use **F08**. Go to display AML232.
- To end the session, use **F24**.

Function keys

F02 RESTART-ITEM causes the Display/Maintain Item Trial Plans Item Selection display (AML231) to appear so that you can select a specific item (without typing a family number) whose trial plan you want to review or change.

F08 NEXT FAMILY shows the item trial plans for the next family in the Production Family Relationship file.

F24 END OF JOB ends processing and causes the Production Planning menu (AMLM10) to appear. The system ignores any information you typed on the display.

Fields

[\[?\]](#) appears next to a field name in the following field definitions to identify a field from which you can begin a master file search.

PLANNING WAREHOUSE [?]. Type the identifier of the warehouse you want to use.

ENTER STARTING FAMILY NUMBER [?]. Type the number of the production family whose item trial plans you want to review or change first. To begin your review with a specific item (without typing a family number), you must use **F02 RESTART-ITEM**.

ENTER STARTING ITEM NUMBER [?]. Type the number of the item if you want to begin your review with a specific item in the production family whose number you typed in the **ENTER STARTING FAMILY NUMBER** field. If you leave this field blank, the system shows you the first item in the family.

AML231—Display/Maintain Item Trial Plans Item Selection

Use this display to you select an item (without typing a family number) whose trial plan you want to review or change.

Note: You must be authorized to the proper level of security in the warehouse you select.

This display appears when you use **F02 RESTART-ITEM** on the Display/Maintain Item Trial Plans Family Selection display (AML230) or on the Display/Maintain Item Trial Plans display (AML232).

```
DATE **/**/**          DISPLAY/MAINTAIN ITEM TRIAL PLANS          AML231  **
                        ITEM SELECTION
PLANNING WAREHOUSE    aA3
ENTER ITEM NUMBER     aaaaaaaaaaaaA15

F01 RESTART-FAMILY
F24 END OF JOB
```

What to do

- To review or maintain the trial plans for a specific item, type in the planning warehouse and item number and press **Enter**. Go to display AML232.
- To return to the Display/Maintain Item Trial Plans Family Selection display (AML230), use **F01** and go to display AML230.
- To end the session, use **F24**.

Function keys

F01 RESTART-FAMILY causes the Display/Maintain Item Trial Plans Family Selection display (AML230) to appear. On it, you can enter a production family number and optionally an item number in that family to begin reviewing item trial plans by production family.

F24 END OF JOB ends processing and causes the Production Planning menu (AMLM10) to appear. The system ignores any information you typed on the display.

Fields

[\[?\]](#) appears next to a field name in the following field definitions to identify a field from which you can begin a master file search.

Contents	Index	Exit
--------------------------	-----------------------	----------------------

PLANNING WAREHOUSE [?]. Type the identifier of the warehouse you want to use.

ENTER ITEM NUMBER [?]. Type the number of the item whose trial plan you want to review or change.

AML232—Display/Maintain Item Trial Plans

Use this display to adjust item trial plans for the items in each family based on changes to family targets or customer demand. You can compare item trial plans to item production plans and make changes (or simulate changes) so that production, adjustments, and held inventory information are current.

This display appears when you:

- Type in a valid production family number and press **Enter** on the Display/Maintain Item Trial Plans Family Selection display (AML230)
- Type in a valid item number and press **Enter** on the Display/Maintain Item Trial Plans Item Selection display (AML231).

```

DATE **/**/**          DISPLAY/MAINTAIN ITEM TRIAL PLANS          AML232 **
ITEM *****          FAMILY *****          ON HAND * ,***,***
DESC *****          SAFETY * ,***,***          HELD * ,***,***
PERIOD  ITEM  PROD PLAN  ---ITEM TRIAL PLAN---  FAMILY  HELD
DATE  PROD PLAN  BLD +/-  NET DEMAND ADJUSTMENT REF  BLD +/-  INVENTORY
**/**/** * ,***,*** * ,***,*** * ,***,*** * ,***,*** ** * ,***,*** * ,***,***

*****
PAGING DATE nnnnnn  F01 RESTART-FAMILY  F07 PREVIOUS ITEM  F10 MAINTAIN PLAN
                   F02 RESTART-ITEM  F08 ERASE ADJ      F23 MORE KEYS
                   F06 NEXT ITEM    F09 HELD INV MAINT F24 END OF JOB

*****
PAGING DATE nnnnnn          F18 REFRESH DISPLAY          F23 MORE KEYS
                              F24 END OF JOB

ENTER HELD INVENTORY nnnnnn          F03 RESUME INQUIRY

QUANTITY nnnnnnn  INCREASE PERIOD nnnnnn  DECREASE PERIOD nnnnnn
                              F03 RESUME INQUIRY
  
```

On this display, you can:

- Review all item production plans and item trial plans in a family.
- Increase or decrease item trial plan adjustments for an item by period. You can see what effect those changes have on the item production plan and the family production targets before you accept the changes.

Contents	Index	Exit
-----------------	--------------	-------------

- Change the current level of held inventory for an item. The system recalculates all fields except **ITEM PROD PLAN** and **ITEM TRIAL PLAN ADJUSTMENT** for each period based on the new level you type in.

When you compare the ITEM TRIAL PLAN (NET DEMAND plus ADJUSTMENT) to the ITEM PROD PLAN, look at the FAMILY BLD +/- (plus or minus). The family's total item trial plans must be adjusted (increased or decreased) in each period to meet the production target for the family. As you complete your changes, the system recalculates the item trial plans, PROD PLAN BLD +/-, and FAMILY BLD +/- for the item until you are ready to accept the adjusted quantities as the item's production plan for use in Master Scheduling.

What to do

- To review item production plans and item trial plans in future periods for this item, press **Enter**. More periods exist if CONTINUED appears in the lower left of the display.
 - To review item production plans and item trial plans for this item starting at a specific date, type the date into the **PAGING DATE** field and press **Enter**.
 - To return to the Display/Maintain Item Trial Plans Family Selection display (AML230), use **F01** and go to display AML230.
 - To return to the Display/Maintain Item Trial Plans Item Selection display (AML231), use **F02** and go to display AML231.
 - To review the production plans and trial plans for the next sequential item in this production family, use **F06**.
 - To review the production plans and trial plans for the previous item in this production family, use **F07**.
- Note:** When you use **F06** or **F07** and the system reaches the last item in the family, the Display/Maintain Item Trial Plans Family Selection display (AML230) appears. If this occurs, go to display AML230.
- To erase (zero out) all adjustments for an item, use **F08**.
 - To change the held inventory level, use **F09**. The **ENTER HELD INVENTORY** field appears at the bottom of display AML232. Do one of the following:
 - To change the held inventory level, type in the required information and press **Enter**.
 - To start the inquiry again without performing any calculations, use **F03**.
 - To increase or decrease production adjustments in the item trial plan, use **F10**. Additional fields appear at the bottom of display AML232. Do one of the following:
 - To change the production adjustment for an item, type in the information requested and press **Enter**. The display shows the changes you made.

Note: Make sure you balance the adjustments; that is, if you increase the adjustment for an item in one period, then decrease the adjustment for that item in another period.
 - To start the inquiry again, use **F03**.
 - To see the display as it was before you changed anything in the fields, use **F18**.
 - To end the session, use **F24**.

Function keys

F01 RESTART-FAMILY causes the Display/Maintain Item Trial Plans Family Selection display (AML230) to appear so you can select a different family. This function key updates the files with any changes you made.

F02 RESTART-ITEM causes the Display/Maintain Item Trial Plans Item Selection display (AML231) to appear so you can select a specific item. This function key updates the files with any changes you made.

F03 RESUME INQUIRY causes display AML232 to appear again in Inquiry mode, and ends any maintenance action you have started. This function key does not appear when the display is in Inquiry mode.

F06 NEXT ITEM causes the production plan and the trial plan for the next sequential item in the production family to appear if you came to this display from the Display/Maintain Item Trial Plans Family Selection display (AML230). This function key returns you to the Display/Maintain Item Trial Plans Item Selection display (AML231) if you came from that display. This function key updates the files with any changes you made.

F07 PREVIOUS ITEM causes the production plan and the trial plan for the previous item in the production family to appear if you came to this display from the Display/Maintain Item Trial Plans Family Selection display (AML230). This function key returns you to the Display/Maintain Item Trial Plans Item Selection display (AML231) if you came from that display. This function key updates the files with any changes you made.

F08 ERASE ADJ (Erase Adjustment) causes the system to zero all adjustments for an item. The **PROD PLAN BLD +/-** (Production Plan Build More or Build Less), **FAMILY BLD +/-** (Family Build More or Build Less), and **HELD INVENTORY** fields are calculated again to show the effects of removing the adjustments. This function key does not update any files, so you can still select **F18 REFRESH DISPLAY** to return the display to its original values.

F09 HELD INV MAINT (Held Inventory Maintenance) causes the **ENTER HELD INVENTORY** field to appear at the bottom of the display. Type in the total quantity of the item you want in held inventory and press **Enter**. The number you enter must be positive. The current held inventory field in the heading of the display (HELD) changes to the amount you typed in, and the held inventory in the body of the display is updated for each period.

F10 MAINTAIN PLAN causes entry fields to appear at the bottom of the display so you can increase or decrease production adjustments by period.

F18 REFRESH DISPLAY causes this display (AML232) to appear as it was before you made any changes.

F23 MORE KEYS allows you to see all the function keys associated with this display.

F24 END OF JOB causes the Production Planning menu (AMLM10) to appear. This function key updates the files with any changes you made.

Fields

Display AML232 has three sections:

- The heading, which shows reference information about the item
- The body, which shows the item's production plan by period
- The lower part of the display, which shows function keys, application and system messages, and entry fields for changing production adjustments and held inventory.

Note: The quantities that appear on this display are not shortened by the quantity significance for the item's family. Quantity significance affects only the family maintenance and inquiry displays and the family quantities on the Family Operating Plan Report (AML271).

The following fields appear in the heading:

ITEM (PFITM). The number of the item whose production plan and trial plan appear in the body of the display.

FAMILY (PFNBR). The number of the production family to which this item belongs.

ON HAND (ITOHD). The total quantity of this item on hand as of the first production planning period.

DESC (Description) (ITDSC). A description of the item. This description is taken from the Item Master file.

SAFETY (Safety Stock) (ITSAF). The total quantity of this item's on-hand inventory set aside for unplanned sales shipments.

HELD (Held Inventory) (ITHLD). The total quantity of this item's on-hand inventory set aside for future planned shipments. It excludes safety stock and unassigned inventory.

The following fields make up the body of the display. Item production plans and trial plans appear in chronological order by period date. Press **Enter** to see the next set of periods, or use the **PAGING DATE** field to see the plans beginning at the date you specify.

The information shown in the body of the display is for review only; you cannot change it by typing over it. To increase or decrease production adjustments or change held inventory, you must use the function keys at the bottom of the display. When you create or change either item adjustments or held inventory, press **Enter** after each change to see the changes on the display. Pressing **Enter** changes the display but does not update the files.

Note: Before you review the fields in the body of the display, it is important to understand the relationship of the major fields:

- **ITEM TRIAL PLAN** field is equal to the current NET DEMAND for an item plus any production ADJUSTMENT you make.
- **PROD PLAN BLD +/-** field contains the amount the ITEM TRIAL PLAN varies from the ITEM PROD PLAN for the period.

Contents	Index	Exit
--------------------------	-----------------------	----------------------

- **FAMILY BLD +/-** field contains the amount that the total of all item trial plans for the family varies from the production target for the family.

PERIOD DATE. The beginning dates of the production planning periods.

ITEM PROD PLAN (Item Production Plan). This is the current item production plan used in the master schedule as the source of demand.

PROD PLAN BLD +/- (Production Plan Build More or Build Less). The amount that the item's production quantity set in the Item Trial Plan varies from the Item Production Plan currently used in master scheduling. For each period, the **PROD PLAN BLD +/-** equals the ITEM TRIAL PLAN minus the ITEM PROD PLAN.

ITEM TRIAL PLAN NET DEMAND. The total quantity of this item that should be produced according to the last aggregation. Net demand is based on the item's blended demand minus its unassigned inventory. Unassigned inventory is determined by subtracting safety stock and held inventory from the item's on-hand inventory as of the first production planning period.

Note: Past-due scheduled receipts are added to the unassigned inventory and past-due customer demand is subtracted from the unassigned inventory.

ITEM TRIAL PLAN ADJUSTMENT. The changes made to an item's trial plan to increase or decrease production to meet the production target for a family.

REF (Reference). General reference codes that indicate scheduling information about an item. The codes are:

- CM** The item's Cumulative Material Lead Time (CMLT) falls within this period. You should be careful when making adjustments within the CMLT, since a change could affect work-in-process schedules.
- PS** Production for the item begins in this period. Production should not be scheduled before this period since tooling may not be available to produce the item. Therefore, you should not specify production adjustments before this period.
- PE** Production for the item ends in this period. Production should not be scheduled after this period since the item may be phased out of production after this date, and replaced by another item. Therefore, you should not specify production adjustments after this period.

Note: If any of these dates fall in the same period, the priority would be CM, PS, then PE.

FAMILY BLD +/- .The amount the family's total item trial plans must be increased or decreased to meet the production target for the family. A minus sign indicates that the family's aggregated item trial plan for the period needs to be decreased by the amount shown. The absence of a sign indicates a positive amount by which you need to increase the family's aggregated item trial plan for the period. For each period, the system calculates the this amount by subtracting the sum of the item trial plans for the family from the production target for the family.

HELD INVENTORY. For each period, the inventory quantity of this item set aside for future planned shipments.

Contents	Index	Exit
--------------------------	-----------------------	----------------------

CONTINUED/END. If CONTINUED appears at the lower left of the display, pressing **Enter** shows you item production plans and item trial plans for the next set of periods. If END appears at the lower left, pressing **Enter** shows you the first set of periods again.

PAGING DATE. If you type a date into this field at the lower left of the display, pressing **Enter** shows you item production plans and item trial plans beginning with the date you type. If the date you type is not a production period beginning date, the system shows you the item production plans and item trial plans for the next period.

Note: If the paging date you type is after the last production period, this display (AML232) appears with the detail lines blank. If this occurs, press **Enter**. The item production plans and item trial plans appear again, beginning with the first production period.

ENTER HELD INVENTORY. See "Function keys."

QUANTITY. Type in the amount by which you want to increase or decrease the item trial plan of an item. This number must be a positive number for both increasing and decreasing production.

INCREASE PERIOD. Type in the date of the period in which you want to increase production. The number you typed in the **QUANTITY** field is added to the adjustment for the period date you type in this field.

DECREASE PERIOD. Type in the date of the period in which you want to decrease production. The number you typed in the **QUANTITY** field is subtracted from the adjustment for the period whose date you type in this field. You can also balance the production adjustments in the item trial plan by period. For example, the quantity that you add to the adjustment for one period, you can subtract from the adjustment in another period. To do this, use the **INCREASE PERIOD** and **DECREASE PERIOD** fields together; that is, you can type one date in the **INCREASE PERIOD** field, and another date in the **DECREASE PERIOD** field. The system adds the quantity to one period and subtract it from the other period.

Note: If you choose not to enter a balanced adjustment, type a date in the **INCREASE PERIOD** or the **DECREASE PERIOD** field, rather than both fields.

Option 6. Replace Family Base Plans (AML10)

Use this option to replace, within the selected planning warehouses, the family base plans with family operating plans for one or all production families. Also, use this option to add a family base plan for a new production family.

Note: You must be authorized to the proper level of security in the warehouse you select.

When a family base plan for a family becomes outdated due to changing demand, production, and inventory conditions, you can replace the family base plan with the more current information in the family operating plan.

You should replace the family base plans periodically, but not frequently. For example, you may choose to replace the plans at the beginning of a new budgeting period.

If you select a range of planning warehouses, all base plans for all planning warehouses within the selected range must be replaced. In addition, if the operating plan date is not equal to or greater than the base plan date, all base plans in the selected planning warehouse must be replaced.

What information you need:

The production family number if you want to replace the base plan for only one production family, and the planning warehouse in which it resides.

What reports are printed:

Replace Family Base Plans Error List (AML221).

What forms you need: None.

The basic steps to replace family base plans follow each display.

AML211—Replace Family Base Plans Selection

Use this display to identify your planning warehouse and to replace one or all family base plans with operating plans or add a new base plan for a specific family.

Note: You must be authorized to the proper level of security in the warehouse you select.

If the operating plan date is not equal to or greater than the base plan date, all base plans in the selected planning warehouse must be replaced.

As sales, production, and inventory conditions change, the family's base plan becomes outdated and is no longer valid to compare to the projections in the operating plan. When this occurs, you can replace the old base plan with the operating plan to create a new base plan for reference and comparison.

You should replace the base plan periodically, but not frequently. For example, you may choose to replace the base plan at the beginning of a new budgeting period.

Note: When you replace the base plan with the operating plan, the system deletes the old Base Plan file. This is the only way you can delete the Base Plan file.

This display appears when you select option 6 on menu AMLM10.

```
DATE  **/**/**          REPLACE FAMILY BASE PLANS          AML211  **
                               SELECTION

      PLANNING WAREHOUSE          aA3
DO YOU WANT TO REPLACE ALL FAMILIES? <Y/N>  A
IF NO, ENTER PRODUCTION FAMILY NUMBER      aaaaaaaaaaaaA15

                                         F24 END OF JOB
```

What to do

- To replace the base plan with the operating plan for one or all production families, or add a base plan for a new family, type in the requested information and press **Enter**. The system begins replacing the base plans with the operating plans by submitting the job to the job queue.
- To end the job without replacing any plans, use **F24**.

Function keys

F24 END OF JOB ends processing and causes the Production Planning menu (AMLM10) to appear. The system ignores any information you typed on the display.

Fields

[\[?\]](#) appears next to a field name in the following field definitions to identify a field from which you can begin a master file search.

PLANNING WAREHOUSE [?]. Type the identifier of the warehouse you want to use.

DO YOU WANT TO REPLACE PLANS FOR ALL FAMILIES? <Y/N>. Type **Y** in this field to replace base plans with operating plans for all production families. If you type **N** in this field, you must type a production family number in the next field. If you must replace all family base plans, this field defaults to Y and cannot be changed.

IF NO, ENTER PRODUCTION FAMILY NUMBER [?]. Type the production family number if you want to replace or add the base plan for only one family. If you typed **Y** in the ***DO YOU WANT TO REPLACE PLANS FOR ALL FAMILIES? <Y/N>*** field, you cannot type in this field.

Option 7. Replace Item Production Plans (AML10)

Use this option to replace item production plans within selected planning warehouses that are currently used in master scheduling with the item trial plans that you have adjusted based on changing sales, production, and inventory conditions. After you make the adjustments, you need to replace the old item production plans with the current information in the item trial plans so that master scheduling is using current information.

Note: If the operating plan date is not equal to the first production period date, all item production plans in the selected planning warehouse must be replaced.

What information you need:

The production family number if you want to replace the production plans with the trial plans for only one family, and the planning warehouse in which it resides.

What reports are printed:

Replace Item Production Plans Error List (AML250).

What forms you need: None.

The basic steps to replace item production plans follow each display.

What to do

- To replace the item production plans with the item trial plans for one or all production families, type in the requested information and press **Enter**. The system begins replacing item production plans with item trial plans by submitting the job to the job queue.
- To end the job without replacing any plans, use **F24**.

Function keys

F24 END OF JOB ends processing and causes the Production Planning menu (AMLM10) to appear. The system ignores any information you typed on the display.

Fields

[\[?\]](#) appears next to a field name in the following field definitions to identify a field from which you can begin a master file search.

PLANNING WAREHOUSE [?]. Type the identifier of the warehouse you want to use.

DO YOU WANT TO REPLACE ALL FAMILIES? <Y/N>. Type **Y** in this field to replace item production plans with item trial plans for all production families. If you type **N** in this field, you must type a production family number in the next field. If you must replace all family base plans, this field defaults to Y and cannot be changed.

IF NO, ENTER PRODUCTION FAMILY NUMBER [?]. Type a production family number in this field if you want to replace the item production plans with item trial plans for only one family. If you typed **Y** in the **DO YOU WANT TO REPLACE PLANS FOR ALL FAMILIES? <Y/N>** field, you cannot type in this field.

Note: The item production plan date must be the same as the operating plan date before you can replace the item production plans for a single family. Replacing the item production plans for all families makes the two dates the same.

Option 8. Family Plan Inquiries (AML10)

Use this option to:

- Review the base plan for a production family in a planning warehouse
- Compare the base plan to the following:
 - Actual history of sales, production, or inventory by period.
 - The projections in the operating plan for sales, production, or inventory by period.
- Compare the production targets in the operating plan with the aggregated plans (item production plans, family trial plans, and master production schedules).

What information you need:

- The number of the production family whose base plan you want to review and the planning warehouse in which it resides.
- The comparison you want to see. Choose one of the following:
 - Base plan versus actual performance (actual history)
 - Base plan versus family operating plan
 - Operating production targets versus aggregated plans.

What reports are printed: None.

What forms you need: None.

The basic steps to inquire into a family plan follow each display.

AML280—Family Plan Inquiries Selection

Use this display to identify your planning warehouse and to select a production family whose base plan, operating plan, and actual performance you want to review and compare.

Note: You must be authorized to the proper level of security in the warehouse you select.

This display appears when you select option 8 on menu AMLM10.

From the Family Plan Inquiries displays, you can:

- Measure the accuracy of the requirements in the base plan against:
 - Projections for sales, production, and inventory by period in the operating plan
 - Actual history of sales, production, and inventory by period.
- Compare the operating plan's production targets with the aggregated plans to ensure that production is meeting the production targets.

```
DATE **/**/**          FAMILY PLAN INQUIRIES          AML280 **
                        SELECTION

PLANNING WAREHOUSE      aA3

ENTER STARTING FAMILY  NUMBER  aaaaaaaaaaA15

SELECT OPTION           n

      1 BASE VS ACTUAL PERFORMANCE
      2 BASE VS OPERATING PLAN
      3 OPERATING PRODUCTION TARGETS VS AGGREGATED PLANS

DISPLAY PLAN IN COSTS OR UNITS <C/U>          A
BASE PLAN COST OR OPERATING PLAN COST <B/O>  A
IF OVERFLOW OCCURS,
CHANGE SIGNIFICANCE FOR THE SESSION <K/M>    A

                                                F24 END OF JOB
```

What to do

- To review the family's base plan, type in the required information, select option 1 or 2 in the **SELECT OPTION** field, and press **Enter**. Go to display AML281.
- To compare the operating plan with the aggregated plans, type in the required information, select option 3 in the **SELECT OPTION** field, and press **Enter**. Go to display AML285.

Note: Selecting option 3 in the **SELECT OPTION** field on this display (AML280) is the only way you can go to the Operating Production Targets vs. Aggregated Plans display (AML285).

- To end the session, use **F24**.

Function keys

F24 END OF JOB ends processing and causes the Production Planning menu (AML10) to appear. The system ignores any information you typed on the display.

Fields

[?] appears next to a field name in the following field definitions to identify a field from which you can begin a master file search.

PLANNING WAREHOUSE [?]. Type the identifier of the warehouse you want to use.

ENTER STARTING FAMILY [?]. Type the number of the production family whose plans you want to review and compare first. Other production families appear in sequential order when you use **F06 NEXT FAMILY** on displays AML281, AML282, AML283, AML284, and AML285.

SELECT OPTION. Type one of the following numbers for the type of comparison:

- 1 Compare the base plan with actual customer sales, actual production receipts, and actual inventory levels.
- 2 Compare the base plan with the projected blended demand, production targets, and inventory levels.
- 3 Compare the family production targets in the operating plan with the aggregated item production plans, trial plans, and master production schedules.

Note: Options 1 and 2 on this display (AML280) determine the type of comparison you see on displays AML282, AML283, or AML284. Option 3 takes you to display AML285 to see a comparison between production targets and aggregated plans.

DISPLAY PLAN IN COSTS OR UNITS <C/U>. Type a **C** (costs) to review the plans in costs or a **U** (units) to review the plans in units. The value you selected when you answered the Questionnaire appears on the display. If you do not type anything in this field, the system uses that value.

BASE PLAN COST OR OPERATING PLAN COST <B/O>. Type a **B** (base plan) for the plans shown in base plan weighted cost or an **O** (operating plan) for the plans shown in the weighted cost calculated in the last aggregation. The value you selected when you answered the Questionnaire appears on the display. If you do not type anything in this field, the system uses that value.

Note: Weighted cost is based on the **STANDARD UNIT COST (STDUC)** field in the Item Balance (ITEMBL) file, and the demand for the item. If STDUC is zero, the system uses the unit cost default (UCDEF) in the Item Master file.

Contents	Index	Exit
--------------------------	-----------------------	----------------------

IF OVERFLOW OCCURS, CHANGE SIGNIFICANCE FOR THIS SESSION

<K/M>. Type in the one-letter code that identifies a new quantity significance to use for this production family for this session. The quantity significance determines how many digits are shown or printed in quantity fields on production planning displays and reports. The codes are:

blank System shows or prints all digits (the full quantity).

K System does not show or print the last three digits (000). Multiply by 1,000 for the actual quantity.

M System does not show or print the last six digits (000,000). Multiply by 1,000,000 for the actual quantity.

For example, if the quantity significance for a production family is (000), the quantity 2,795 is actually 2,795,000. This method of shortening quantities makes them easier to read and adjusts very large quantities that exceed the length of the fields in which they appear.

Note: This field does not show a quantity significance code initially. If you leave the field blank when you enter a new production family number, the significance assigned to the family on display AML361 during file maintenance appears in the **SIGNIFICANCE** field on displays AML281 through AML285. When you return to display AML280 from displays AML281 through AML285, the code for that significance value appears in this field.

The primary purpose of this field is to allow you to recover if message W AM-8571 OVERFLOW HAS OCCURRED ON THIS DISPLAY appears on displays AML281 through AML285. You can then return to this display and temporarily change the significance for this session by entering a new significance code (K or M). In this way, you can look at the quantities in fields where overflow has occurred. The value you type in remains until one of the following happens:

- You change the quantity significance code again.
- You select a different family to review.
- You end the job (**F24**).

Note: To change the quantity significance for the family permanently, use production family maintenance (option 10 on the Production Planning menu, AMLM10). For more information about quantity significance, see "Option 10. Display and Maintain Production Families (AMLM10)".

What to do

- To review another set of periods in the base plan for this family, press **Enter**. More periods exist if CONTINUED appears in the lower left of the display.
- To review the base plan for this family starting at a specific date, type the date into the **PAGING DATE** field and press **Enter**.
- To review the base plan for the next sequential family, use **F06**.

Note: When you use **F06** and the system reaches the last family in the file, the Family Plan Inquiries Selection display (AML280) appears. If this occurs, go to display AML280.

- To change the method (costs or units) in which the base plan is shown, use **F07**.
- To compare the base plan production to the actual production or operating plan production for the family by period, use **F10** and go to display AML282.
- To compare the base plan demand to the actual sales or operating plan demand by period, use **F11** and go to display AML283.
- To compare the base plan inventory to the actual inventory or operating plan inventory by period, use **F12** and go to display AML284.
- To return to the Family Plan Inquiries Selection display (AML280), use **F19** and go to display AML280.
- To end the session, use F24.

Function keys

F06 NEXT FAMILY causes the base plan for the next sequential family to appear.

F07 COSTS/UNITS lets you review the base plan in costs or units. Use this function key to switch between costs and units.

F10 PRODUCTION causes the Base Plan Inquiry Production Plan display (AML282) to appear so you can compare the base plan production to the actual or operating plan production quantities, depending on whether you selected option 1 or option 2 on display AML280.

F11 DEMAND causes the Base Plan Inquiry Demand Plan display (AML283) to appear so you can compare the base plan demand to the actual or operating plan demand quantities, depending on whether you selected option 1 or option 2 on display AML280.

F12 INVENTORY causes the Base Plan Inquiry Inventory display (AML284) to appear so you can compare the base plan projected inventory to the actual or operating plan projected inventory quantities, depending on whether you selected option 1 or option 2 on display AML280.

F19 RETURN TO SELECT causes the Family Plan Inquiries Selection display (AML280) to appear.

F24 END OF JOB ends processing and causes the Production Planning menu (AML10) to appear.

Fields

BASE VS ACTUAL PERFORMANCE or BASE VS OPERATING PLAN. One of two phrases that appears below the title of the display, based on whether you selected option 1 or option 2 on the Family Plan Inquiries Selection display (AML280). If you selected option 1, you can compare the base plan to actual performance and if you selected option 2, you can compare the base plan to the latest projections in the operating plan for the family.

FAMILY (PFNBR). The number of the production family whose base plan you are reviewing.

PLAN DATE. The operating plan date of the family when the base plan was replaced. The system stored this date in the Base Plan (BASEPL) file when you replaced the base plan with the operating plan for the family.

BASE PLAN or OPERATING PLAN. The type of cost (base plan or operating plan), if you selected cost on the Family Plan Inquiries Selection display (AML280). The words BASE PLAN or OPERATING PLAN appear.

COSTS or UNITS. The method (costs or units) in which the plans are shown. The word COSTS or UNITS appears. You can use **F07** to switch between costs and units.

DESC (Description) (ITDSC). The description of the production family whose base plan you want to review.

SIGNIFICANCE (Quantity Significance) (PFSIG). The number of field positions (digits) the quantity fields are shortened on production planning displays and reports.

You see one of the following in this field:

- () System shows all digits (the full quantity).
- (000) System does not show the last three digits (000). Multiply by 1,000 for the actual quantity.
- (000,000) System does not show the last six digits (000,000). Multiply by 1,000,000 for the actual quantity.

For example, if the quantity significance for a production family is (000), the quantity 2,795 is actually 2,795,000.

ON HAND (BPOHD). The total quantity of items in inventory in this family at the beginning of the first period in the base plan.

SAFETY (BPSAF). The aggregated safety stock at the beginning of the first period in the base plan.

HELD (BPHLD). The total quantity of items in this family's inventory set aside for future planned shipments at the beginning of the first period in the base plan.

BALANCE. The quantity of items in this family that is unassigned at the beginning of the first period in the base plan. The production family balance equals family on-hand inventory minus family safety stock minus family held inventory.

PERIOD DATE. The beginning dates of the production planning periods. If you selected option 1 (Base vs. Actual Performance) on the Family Plan Inquiries Selection display (AML280), the dates you see begin with the PLAN DATE. If you selected option 2 (Base vs. Operating Plan), the dates you see begin with the operating plan date.

PRODUCTION. The base plan's total quantity (production targets) of items that management wanted to produce for this family. This quantity was based on expected sales and the desired level of inventory.

BLENDED DEMAND. The base plan's blended demand for the family which is the result of aggregating the blended demand of each item in the family. Blended demand is the greater of forecast or customer orders for each period.

PROJECTED INVENTORY. The quantity of items in this family expected in inventory at the end of a period. The projected inventory is the period's production target plus available inventory (projected inventory from the previous period) minus blended demand. Available inventory for the first period is the on-hand inventory. If the projected inventory is less than the family safety stock anytime during the period, this field is highlighted.

CONTINUED/END. If CONTINUED appears at the lower left of the display, pressing **Enter** shows you base plan information for the next set of periods. If END appears at the lower left, pressing **Enter** shows you the first periods again.

PAGING DATE. If you type a date into this field at the lower left of the display, pressing **Enter** shows you the base plan information for production families beginning with the date you type. If the date you type is not a production period beginning date, the system shows you the plan for the next period.

Note: If the paging date you type is after the last production period, this display (AML281) appears with the detail lines blank. If this occurs, press **Enter**. The base plan appears again, beginning with the first production period.

Contents	Index	Exit
--------------------------	-----------------------	----------------------

AML282—Base Plan Inquiry Production Plan

Use this display to see how much the production quantities set in the base plan vary with actual production or vary with current production quantities in the operating plan for a family. The display shows the amount the quantities vary for each period and the variance amounts and percentages accumulated from period to period.

This display appears when you use **F10** on displays AML281, AML283, or AML284.

Note: To go to the Operating Production Targets vs. Aggregated Plans display (AML285) from displays AML281, AML282, AML283, or AML284, you must use **F19** to return to the Family Plan Inquiries Selection display (AML280).

```

DATE **/**/**                                BASE PLAN INQUIRY                                AML282 **
                                           PRODUCTION PLAN
FAMILY *****                                PLAN DATE **/**/**                                BASE PLAN UNITS
DESC *****                                SIGNIFICANCE (
PERIOD                                     VARIANCE CUMULATIVE
DATE                                     PERCENT VARIANCE
**/**/**                                *,*,*,*
                                           *,*,*,*
                                           *,*,*,*
                                           **
                                           *,*,*,*

*****
PAGING DATE nnnnn  F03 RESUME INQUIRY  F07 COSTS/UNITS  F19 RETURN TO SELECT
                   F06 NEXT FAMILY    F11 DEMAND
                                       F12 INVENTORY    F24 END OF JOB

```

What to do

- To review another set of periods in the production plan for this family, press **Enter**. More periods exist if CONTINUED appears in the lower left of the display.
 - To review the production plan for this family starting at a specific date, type the date into the **PAGING DATE** field and press **Enter**.
 - To return to the Base Plan Inquiry display (AML281), use **F03** and go to display AML281.
 - To review the production plan for the next sequential family, use **F06**.
- Note:** When you use **F06** and the system reaches the last family in the file, the Family Plan Inquiries Selection display (AML280) appears. If this occurs, go to display AML280.
- To change the method (costs or units) in which the production plan is shown, use **F07**.
 - To compare the base plan demand to the actual sales or operating plan demand for the family by period, use **F11** and go to display AML283.
 - To compare the base plan inventory to the actual inventory or operating plan inventory for the family by period, use **F12** and go to display AML284.

- To return to the Family Plan Inquiries Selection display (AML280), use **F19**.
- To end the session, use **F24**.

Function keys

F03 RESUME INQUIRY causes the Base Plan Inquiry display (AML281) to appear.

F06 NEXT FAMILY causes the production plan for the next sequential family to appear.

F07 COSTS/UNITS lets you review the operating plan in costs or units. Use this function key to switch between costs and units.

F11 DEMAND causes the Base Plan Inquiry Demand Plan display (AML283) to appear so you can compare the base plan demand to the actual or operating plan demand quantities, depending on whether you selected option 1 or option 2 on display AML280.

F12 INVENTORY causes the Base Plan Inquiry Inventory display (AML284) to appear so you can compare the base plan projected inventory to the actual or operating plan projected inventory, depending on whether you selected option 1 or option 2 on display AML280.

F19 RETURN TO SELECT causes the Family Plan Inquiries Selection display (AML280) to appear.

F24 END OF JOB ends processing and causes the Production Planning menu (AMLM10) to appear.

Fields

FAMILY (PFNBR). The number of the production family whose base plan you are reviewing.

PLAN DATE. The operating plan date of the family when the base plan was replaced. The system stored this date in the Base Plan (BASEPL) file when you replaced the base plan with the operating plan for the family.

BASE PLAN or OPERATING PLAN. The type of cost (base plan or operating plan), if you selected cost on the Family Plan Inquiries Selection display (AML280). The words BASE PLAN or OPERATING PLAN appear.

COSTS or UNITS. The method in which the plans are shown. The word COSTS or UNITS appears. You can use **F07** to switch between costs and units.

DESC (Description) (ITDSC). The description of the production family whose base plan you want to review.

SIGNIFICANCE (Quantity Significance) (PFSIG). The number of field positions (digits) the quantity fields are shortened on production planning displays and reports.

You see one of the following in this field:

- () System shows all digits (the full quantity).
- (000) System does not show the last three digits (000). Multiply by 1,000 for the actual quantity.
- (000,000) System does not show the last six digits (000,000). Multiply by 1,000,000 for the actual quantity.

For example, if the quantity significance for a production family is (000), the quantity 2,795 is actually 2,795,000.

PERIOD DATE. The beginning dates of the production planning periods. If you selected option 1 (Base vs. Actual Performance) on the Family Base Plan Inquiries Selection display (AML280), the dates you see begin with the PLAN DATE. If you selected option 2 (Base vs. Operating Plan), the dates you see begin with the operating plan date.

BASE PRODUCTION. The base plan's total quantity (production targets) of items that management wanted to produce for this family. This quantity, which is stored in the Base Plan (BASEPL) file, was based on expected sales and the desired level of inventory.

ACTUAL PRODUCTION or OPERATING PRODUCTION. The total quantity of items actually produced for this family and received into inventory, if you selected option 1 on the Family Plan Inquiries Selection display (AML280). If you selected option 2 on display AML280, this field shows you the production target in the family operating plan.

VARIANCE. The amount that the actual production quantities or the production target (based on your choice on display AML280) varies from the quantities set in the base plan. If the actual or operating quantities are greater than the base plan, the variance is positive. If the quantities are less than the base plan, the variance is negative.

VARIANCE PERCENT. The percentage (rounded) that the actual production quantities or the production target (based on your choice on display AML280) varies from the quantities set in the base plan. The variance percent is equal to the variance amount divided by the base plan production quantity. Like the variance, the variance percent can be positive or negative.

CUMULATIVE VARIANCE. The accumulated amount that the actual production quantities or the production target (based on your choice on display AML280) varies from the quantities in the base plan for a period. This amount can be positive or negative.

CONTINUED/END. If CONTINUED appears at the lower left of the display, pressing **Enter** shows you production plan information for the next set of periods. If END appears at the lower left, pressing **Enter** shows you the first periods again.

Contents	Index	Exit
--------------------------	-----------------------	----------------------

PAGING DATE. If you type a date into this field at the lower left of the display, pressing **Enter** shows you the production plan information for production families beginning with the date you type. If the date you type is not a production period beginning date, the system shows you the plan for the next period.

Note: If the paging date you type is after the last production period, this display (AML282) with the last available period of data shown.

AML283—Base Plan Inquiry Demand Plan

Use this display to see how much the demand (forecasted sales) quantities set in the base plan vary with the actual demand or the current demand quantities in the operating plan for a family. The display shows the amount the quantities vary for each period and the variance amounts accumulated from period to period.

This display appears when you use **F11** on displays AML281, AML282 or AML284.

Note: To go to the Operating Production Targets vs. Aggregated Plans display (AML285) from displays AML281, AML282, AML283, or AML284, you must use F19 to return to the Family Plan Inquiries Selection display (AML280).

```

DATE **/**/**                BASE PLAN INQUIRY                AML283 **
                             DEMAND PLAN
FAMILY *****
DESC *****
PERIOD      BASE      OPERATING      VARIANCE      SIGNIFICANCE (
DATE        DEMAND    DEMAND      * , * , *     PERCENT      CUMULATIVE
**/**/**   * , * , *     * , * , *     * , * , *     * , * , *     )
*****
PAGING DATE nnnnnn          F03 RESUME INQUIRY  F07 COSTS/UNITS  F19 RETURN TO SELECT
                             F06 NEXT FAMILY    F10 PRODUCTION   F24 END OF JOB
                             F12 INVENTORY

```

What to do

- To review another set of periods in the demand plan for this family, press **Enter**. More periods exist if CONTINUED appears in the lower left of the display.
 - To review the demand plan for this family starting at a specific date, type the date into the **PAGING DATE** field and press **Enter**.
 - To return to the Base Plan Inquiry display (AML281), use **F03**. Go to display AML281.
 - To review the demand plan for the next sequential family, use **F06**.
- Note:** When you use **F06** and the system reaches the last family in the file, the Family Plan Inquiries Selection display (AML280) appears.
- To change the method (costs or units) in which the demand plan is shown, use **F07**.
 - To compare the base plan production to the actual production or operating plan production for the family by period, use **F10** and go to display AML282.
 - To compare the base plan inventory to the actual inventory or operating plan inventory for the family by period, use **F12** and go to display AML284.
 - To return to the Family Plan Inquiries Selection display (AML280), use **F19**.

- To end the session, use **F24**.

Function keys

F03 RESUME INQUIRY causes the Base Plan Inquiry display (AML281) to appear.

F06 NEXT FAMILY causes the base demand plan for the next sequential family to appear.

F07 COSTS/UNITS lets you review the base plan in costs or units. Use this function key to switch between costs and units.

F10 PRODUCTION causes the Base Plan Inquiry Production Plan display (AML282) to appear so you can compare the base plan production to the actual or operating plan production quantities, depending on whether you selected option 1 or option 2 on display AML280.

F12 INVENTORY causes the Base Plan Inquiry Inventory display (AML284) to appear so you can compare the base plan projected inventory to the actual or operating plan projected inventory quantities, depending on whether you selected option 1 or option 2 on display AML280.

F19 RETURN TO SELECT causes the Family Plan Inquiries Selection display (AML280) to appear.

F24 END OF JOB ends processing and causes the Production Planning menu (AML10) to appear.

Fields

FAMILY (PFNBR). The number of the production family whose base plan you are reviewing.

PLAN DATE. The operating plan date of the family when the base plan was replaced. The system stored this date in the Base Plan (BASEPL) file when you replaced the base plan with the operating plan for the family.

BASE PLAN or OPERATING PLAN. The type of cost (base plan or operating plan), if you selected cost on the Family Plan Inquiries Selection display (AML280). The words BASE PLAN or OPERATING PLAN appear.

COSTS or UNITS. The method in which the plans are shown. The word COSTS or UNITS appears. You can use **F07** to switch between costs and units.

DESC (Description) (ITDSC). The description of the production family whose base plan you want to review or compare.

SIGNIFICANCE (Quantity Significance) (PFSIG). The number of field positions (digits) the quantity fields are shortened on production planning displays and reports.

You see one of the following in this field:

- () System shows all digits (the full quantity).
- (000) System does not show the last three digits (000). Multiply by 1,000 for the actual quantity.
- (000,000) System does not show the last six digits (000,000). Multiply by 1,000,000 for the actual quantity.

For example, if the quantity significance for a production family is (000), the quantity 2,795 is actually 2,795,000.

PERIOD DATE. The beginning dates of the production planning periods. If you selected option 1 (Base vs. Actual Performance) on the Selection display (AML280), the dates you see begin with the PLAN DATE. If you selected option 2 (Base vs. Operating Plan), the dates you see begin with the operating plan date.

BASE DEMAND. The base plan's total blended demand for the family. It is the result of aggregating the blended demand of each item in the family. It shows the demand projected for the family when you accepted this plan as the base plan.

ACTUAL DEMAND or OPERATING DEMAND. The total quantity of items in this family actually sold, if you selected option 1 on the Family Plan Inquiries Selection display (AML280). The word ACTUAL appears.

If you selected option 2 on display AML280, this field shows you the blended demand for the family. The word OPERATING appears.

VARIANCE. The amount that the actual sales quantities or the blended demand in the operating plan (based on your choice on display AML280) varies from the quantities set in the base plan for the family. If the actual or operating quantities are greater than the base plan, the variance is positive. If the quantities are less than the base plan, the variance is negative.

VARIANCE PERCENT. The percentage (rounded) that the actual sales quantities or the blended demand (based on your choice on display AML280) varies from the quantities set in the base plan for the family. The variance percent is equal to the variance amount divided by the base plan demand quantity. Like the variance, the variance percent can be positive or negative.

CUMULATIVE VARIANCE. The accumulated amount that the actual sales quantities or the blended demand (based on your choice on display AML280) varies from the quantities set in the base plan for a period. This amount can be positive or negative.

CONTINUED/END. If CONTINUED appears at the lower left of the display, pressing **Enter** shows you demand plan information for the next set of periods. If END appears at the lower left, pressing **Enter** shows you the first periods again.

Contents	Index	Exit
--------------------------	-----------------------	----------------------

PAGING DATE. If you type a date into this field at the lower left of the display, pressing **Enter** shows you the demand plan information for production families beginning with the date you type. If the date you type is not a production period beginning date, the system shows you the plan for the next period.

Note: If the paging date you type is after the last production period, this display (AML283) appears with the last available period of data shown.

AML284—Base Plan Inquiry Inventory Plan

Use this display to see how much the inventory quantities set in the base plan vary with the actual inventory or the current inventory quantities in the operating plan for a family. The display shows the amount the quantities vary for each period and the variance amounts accumulated from period to period.

This display appears when you use **F12** on displays AML281, AML282, or AML283.

Note: To go to the Operating Production Targets vs. Aggregated Plans display (AML285) from displays AML281, AML282, AML283, or AML284, you must use F19 to return to the Family Plan Inquiries Selection display (AML280).

DATE **/**/**	BASE PLAN INQUIRY INVENTORY PLAN			AML284 **
FAMILY *****	PLAN DATE **/**/**			BASE PLAN UNITS
DESC *****	SIGNIFICANCE ()			CUMULATIVE
PERIOD	BASE INVENTORY	OPERATING INVENTORY	VARIANCE	VARIANCE PERCENT
DATE **/**/**	* , ** , **	* , ** , **	* , ** , **	* , ** , **
<div style="display: flex; justify-content: space-between; font-size: small;"> ***** PAGING DATE nnnnn F03 RESUME INQUIRY F06 NEXT FAMILY F07 COSTS/UNITS F10 PRODUCTION F11 DEMAND F19 RETURN TO SELECT F24 END OF JOB </div>				

What to do

- To review another set of periods in the inventory plan for this family, press **Enter**. More periods exist if CONTINUED appears in the lower left of the display.
 - To review the inventory plan for this family starting at a specific date, type the date into the **PAGING DATE** field and press **Enter**.
 - To return to the Base Plan Inquiry display (AML281), use **F03** and go to display AML281.
 - To review the inventory plan for the next sequential family, use **F06**.
- Note:** When you use **F06** and the system reaches the last family in the file, the Family Plan Inquiries Selection display (AML280) appears.
- To change the method (costs or units) in which the inventory plan is shown, use **F07**.
 - To compare the base plan production to the actual production or operating plan production for the family by period, use **F10** and go to display AML282.
 - To compare the base plan demand to the actual sales or operating plan demand for the family by period, use **F11** and go to display AML283.
 - To return to the Family Plan Inquiries Selection display (AML280), use **F19**.

- To end the session, use **F24**.

Function keys

F03 RESUME INQUIRY causes the Base Plan Inquiry display (AML281) to appear.

F06 NEXT FAMILY causes the inventory plan for the next sequential family to appear.

F07 COSTS/UNITS lets you review the operating plan in costs or units. Use this function key to switch between costs and units.

F10 PRODUCTION causes the Base Plan Inquiry Production Plan display (AML282) to appear so you can compare the base plan production to the actual or operating plan production quantities, depending on whether you selected option 1 or option 2 on display AML280.

F11 DEMAND causes the Base Plan Inquiry Demand display (AML283) to appear so you can compare the base plan demand to the actual or operating plan demand quantities, depending on whether you selected option 1 or option 2 on display AML280.

F19 RETURN TO SELECT causes the Family Plan Inquiries Selection display (AML280) to appear.

F24 END OF JOB ends processing and causes the Production Planning menu (AMLM10) to appear.

Fields

FAMILY (PFNBR). The number of the production family whose base plan you are reviewing.

PLAN DATE. The operating plan date of the family when the base plan was replaced. The system stored this date in the Base Plan (BASEPL) file when you replaced the base plan with the operating plan for the family.

BASE PLAN or OPERATING PLAN. The type of cost (base plan or operating plan), if you selected cost on the Family Plan Inquiries Selection (AML280) display. The words BASE PLAN or OPERATING PLAN appear.

COSTS or UNITS. The method in which the plans are shown. The word COSTS or UNITS appears. You can use **F07** to switch between costs and units.

DESC (Description) (ITDSC). The description of the production family whose base plan you want to review.

SIGNIFICANCE (Quantity Significance) (PFSIG). The number of field positions (digits) the quantity fields are shortened on production planning displays and reports.

You see one of the following in this field:

- () System shows all digits (the full quantity).
- (000) System does not show the last three digits (000). Multiply by 1,000 for the actual quantity.
- (000,000) System does not show the last six digits (000,000). Multiply by 1,000,000 for the actual quantity.

For example, if the quantity significance for a production family is (000), the quantity 2,795 is actually 2,795,000.

PERIOD DATE. The beginning dates of the production planning periods. If you selected option 1 (Base vs. Actual Performance) on the Selection display (AML280), the dates you see begin with the PLAN DATE. If you selected option 2 (Base vs. Operating Plan), the dates you see begin with the operating plan date.

BASE INVENTORY. The total quantity of items projected to be in inventory at the end of a period according to the base plan for the family. The base plan inventory is the base plan target plus available inventory (inventory from the previous period) minus blended demand. Available inventory for the first period is the base plan on-hand inventory.

ACTUAL INVENTORY or OPERATING INVENTORY. The total quantity of items in this family calculated to be in inventory at the end of a period, if you selected option 1 on the Family Plan Inquiries Selection display (AML280). If you selected option 2 on display AML280, this field shows you the ending inventory quantities in the operating plan for the family.

Actual inventory equals the base plan on-hand inventory plus actual receipts minus actual sales. Actual inventory is calculated only for the periods before and including the operating plan date and cannot be calculated beyond the operating plan date.

Operating plan inventory equals available inventory (inventory from the previous period) plus production targets minus blended demand. Available inventory for the first period is the operating plan on-hand inventory.

VARIANCE. The amount that the actual ending inventory or the ending inventory quantities in the operating plan (based on your choice on display AML280) vary from the base plan for the family. If the actual or operating quantities are greater than the base plan, the variance is positive. If the quantities are less than the base plan, the variance is negative.

VARIANCE PERCENT. The percentage (rounded) that the actual ending inventory or the ending inventory quantities in the operating plan (based on your choice on display AML280) vary from the base plan for the family. The variance percent is equal to the variance amount divided by the base plan demand quantity. Like the variance, the variance percent can be positive or negative.

CUMULATIVE VARIANCE. The accumulated amount that the actual ending inventory or the ending inventory quantities in the operating plan vary from the base plan for a period. This amount can be positive or negative.

Contents	Index	Exit
--------------------------	-----------------------	----------------------

CONTINUED/END. If CONTINUED appears at the lower left of the display, pressing **Enter** shows you inventory plan information for the next set of periods. If END appears at the lower left, pressing **Enter** shows you the first periods again.

PAGING DATE. If you type a date into **PAGING DATE** at the lower left of the display, pressing **Enter** shows you the inventory plan information for production families beginning with the date you type. If the date you type is not a production period beginning date, the system shows you the plan for the next period.

Note: If the paging date you type is after the last production period, this display (AML284) appears with the last available period of data shown.

AML285—Operating Production Targets vs. Aggregated Plans

Use this display to compare aggregated item production plans, family trial plans, and master production schedules to the production targets for the family. The display shows the percentage each plan varies from the production target for each period.

This display appears when you select option 3 on the Family Plan Inquiries Selection display (AML280).

```

DATE **/**/**                OPERATING PRODUCTION TARGETS                AML285  **
                               VS AGGREGATED PLANS
FAMILY *****
DESC *****
PERIOD  PRODUCTION  -----AGGREGATED PLAN-----  BASE PLAN UNITS
DATE    TARGET      IPP      TRIAL      MPS      SIGNIFICANCE ( )
**/**/**  *,***,**  *,***,**  *,***,**  *,***,**  IPP  TRIAL  MPS
                               ---VARIANCE PCT---
                               ***  ***  ***

*****
PAGING DATE nnnnnn

F06 NEXT FAMILY  F19 RETURN TO SELECT
F07 COSTS/UNITS  F24 END OF JOB

```

What to do

- To review another set of periods in the operating plan for this family, press **Enter**. More periods exist if CONTINUED appears in the lower left of the display.
- To review the operating plan for this family starting at a specific date, type the date into the **PAGING DATE** field and press **Enter**.
- To review the operating plan for the next sequential family, use **F06**.
Note: When you use **F06** and the system reaches the last family in the file, the Family Plan Inquiries Selection display (AML280) appears.
- To change the method (costs or units) in which the operating plan is shown, use **F07**.
- To return to the Family Plan Inquiries Selection display (AML280), use **F19**.
- To end the session, use **F24**.

Function keys

F06 NEXT FAMILY causes the operating plan for the next sequential family to appear.

F07 COSTS/UNITS lets you review the operating plan in costs or units. Use this function key to switch between costs and units.

F19 RETURN TO SELECT causes the Family Plan Inquiries Selection display (AML280) to appear.

F24 END OF JOB ends processing and causes the Production Planning menu (AMLM10) to appear.

Fields

FAMILY (PFNBR). The number of the production family whose production targets and plans you are reviewing.

PLAN DATE. The beginning date of the first period in your family operating plan. This date is stored during aggregation.

BASE PLAN or OPERATING PLAN. The type of cost (base plan or operating plan) you selected on the Family Plan Inquiries Selection display (AML280). The words BASE PLAN or OPERATING PLAN appear.

COSTS or UNITS. The method in which the plans are shown. The word COSTS or UNITS appears. You can use **F07** to switch between costs and units.

DESC (Description) (ITDSC). The description of the production family whose targets and plans you want to review.

SIGNIFICANCE (Quantity Significance) (PFSIG). The number of field positions (digits) the quantity fields are shortened on production planning displays and reports.

You see one of the following in this field:

- () System shows all digits (the full quantity).
- (000) System does not show the last three digits (000). Multiply by 1,000 for the actual quantity.
- (000,000) System does not show the last six digits (000,000). Multiply by 1,000,000 for the actual quantity.

For example, if the quantity significance for a production family is (000), the quantity 2,795 is actually 2,795,000.

PERIOD DATE. The beginning dates of the production planning periods. The dates you see begin with the operating plan date.

PRODUCTION TARGET. The total quantity of items in this family that management wants to produce for the period. Management sets this number based on expected sales and desired inventory.

Contents	Index	Exit
--------------------------	-----------------------	----------------------

AGGREGATED PLAN. The following fields show quantities (calculated during aggregation) for each plan by period for you to compare to the production target in each period.

IPP (Item Production Plan): The current item production plans used in the master schedule.

TRIAL: The result of the system's adding the family net demand to the family adjustments for this period.

MPS (Master Production Schedule): The open, planned, and firm planned orders for the items in this family for this period. Master production schedules are lot-sized from the item production plans.

VARIANCE PCT (Variance Percent). The following three fields show the percentage (rounded) that each plan varies from the production target in each period. If the percent which the plan varies from the plan is greater than the production target, the variance percent is positive. If the percent which the plan varies from the plan is less than the production target, the variance percent is negative.

IPP (Item Production Plan): The percent that the aggregated item production plans for the family vary from the production target for the period.

TRIAL: The percent that the aggregated net demand plus adjustments for the items in this family vary from the production target in each period.

MPS (Master Production Schedule): The percent that the aggregated master production schedules for the items in this family vary from the production target in each period.

CONTINUED/END. If CONTINUED appears at the lower left of the display, pressing **Enter** shows you production targets and aggregated plans for the next set of periods. If END appears at the lower left, pressing **Enter** shows you the first periods again.

PAGING DATE. If you type a date into this field at the lower left of the display, pressing **Enter** shows you production targets and aggregated plans beginning with the date you type. If the date you type is not a production period beginning date, the system shows you the production targets and aggregated plans for the next period.

Note: If the paging date you type is after the last production period, this display (AML285) appears with the last available period of data shown.

Option 9. Family Operating Plan Report (AMLM10)

Use this option to print, for a selected planning warehouse, the Family Operating Plan Report (AML271) for one or more families for twelve consecutive periods. You can optionally include the item production plans for all items in each family, and the daily production quantities for items and families. You can also print the quantities in costs or units.

What information you need:

- The number of the production family if you want to print the report for only one family and the planning warehouse in which it resides.
- The beginning and ending production family numbers if you want the report printed for a range of families and the planning warehouses in which they reside.
- The period beginning date from which you want the report to be printed.

What reports are printed:

Family Operating Plan Report (AML271).

What forms you need: None.

The basic steps to generate a Family Operating Plan Report follow each display.

AML261—Family Operating Plan Report Options

Use this display to define the contents of the Family Operating Plan Report (AML261) and submit the report to the job queue. You choose the range of families want on the report and optionally whether you want to print item production plans for each family.

Note: You must be authorized to the proper level of security in the warehouse you select.

This display appears when you select option 9 on menu AMLM10.

DATE **/**/**	FAMILY OPERATING PLAN REPORT OPTIONS	AML261 **
PLANNING WAREHOUSE	aA3	
ENTER FAMILY RANGE	aaaaaaaaaaaaA15 aaaaaaaaaaaaA15	
ENTER STARTING PERIOD DATE	nnnnn	
PRINT FAMILY PLAN IN COSTS OR UNITS <C/U>	A	
PRINT ITEM DETAIL <Y/N>	A	
PRINT DAILY RATES <Y/N>	A	
F24 END OF JOB		

What to do

- To request that the report is printed for all families, leave the **ENTER FAMILY RANGE** field blank. Type in the remaining information and press **Enter**. The system submits the job to the job queue.
- To print the report for a range of families, do one of the following:
 - Type in a beginning family number and ending family number in the beginning and ending range of the **ENTER FAMILY RANGE** field. Type in the remaining information and press **Enter**. The system submits the job to the job queue.
 - Type in a family number only in the beginning range of the **ENTER FAMILY RANGE** field. The report is printed for all the production families beginning with that family number. Type in the remaining information and press **Enter**. The system submits the job to the job queue.
- To request that the report is printed for only one family, type the same production family number in the beginning and ending range of the **ENTER FAMILY RANGE** field. Type in the remaining information and press **Enter**. The system submits the job to the job queue.
- To end the job without the report being printed, use **F24**.

Function keys

F24 END OF JOB ends processing and causes the Production Planning menu (AMLM10) to appear. The system ignores any information you typed on the display.

Fields

[\[?\]](#) appears next to a field name in the following field definitions to identify a field from which you can begin a master file search.

PLANNING WAREHOUSE [?]. Type the identifier of the warehouse you want to use.

ENTER FAMILY RANGE [?]. Leave this field blank to print the report for all families. Type in a family number in the field's beginning range to print the report for all families from that number forward. Type in the same family number in both the beginning and ending range of the field to print the report for only one family.

ENTER STARTING PERIOD DATE. Type in the beginning date of the first period to be printed on the report. The report includes information for 12 consecutive periods beginning with the date you enter in this field.

PRINT FAMILY PLAN IN COSTS OR UNITS <C/U>. Type in **C** to print the demand, inventory, and production information in costs, or type in **U** to print the information in units. Both family and item information print in the method you choose. If you do not type anything in this field, the system uses the value you selected when you answered the Questionnaire.

PRINT ITEM DETAIL <Y/N>. Type in **Y** to print the supporting item plans for each family. Type in **N** to not print the plans. If you choose to print the item information, it is printed for all the families you selected in the **ENTER FAMILY RANGE** field. The value you selected when you answered the Questionnaire appears on the display. If you do not type anything in this field, the system uses that value.

PRINT DAILY RATES <Y/N>. Type in **Y** to print the daily production quantities for families and items. Type in **N** if you do not need this information. The **RATE/DAY** field in the heading of the report (the maximum or desired quantity that you can produce in one working day for a family) is always printed even if you type **N** in this field. The value you selected when you answered the Questionnaire appears on the display. If you do not type anything in this field, the system uses that value.

Option 10. Display and Maintain Production Families (AMLM10)

Use this option to:

- Review the items assigned to a production family in a planning warehouse
- Review information about the master scheduled items assigned to a production family in a planning warehouse
- Add a master scheduled item to a production family in a planning warehouse
- Change or delete the master scheduled items assigned to a production family in a planning warehouse
- Delete all members from a production family in a planning warehouse
- Change the rate per day or the quantity significance for a production family in a planning warehouse.
- Set options for including or excluding during aggregation, by production family, or by item in the family, adjusted on-hand inventory, held inventory, and safety stock.

What information you need:

- The number of the production family you want to review or maintain and the planning warehouse in which it resides
- The item number, priority, and scheduling dates for any item you want to add

Note: The items you add must be end items. They should also be master scheduled and should use production plans as their demand source.

- The rate per day and the quantity significance to use for this production family, if you want to change them.

What reports are printed: None.

What forms you need: None.

The basic steps to display and maintain production families follow each display.

AML360—Display/Maintain Production Families Selection

Use this display to select the production family to review, add to, change, or delete.

Note: You must be authorized to the proper level of security in the warehouse you select.

This display appears when you select option 10 on menu AMLM10.

DATE **/**/**	DISPLAY/MAINTAIN PRODUCTION FAMILIES SELECTION	AML360 **
	PLANNING WAREHOUSE	aA3
	ENTER PRODUCTION FAMILY NUMBER	aA3
	AGGREGATION OPTIONS FOR THIS PRODUCTION FAMILY: (1 = INCLUDE, 2 = EXCLUDE)	
	ADJUSTED ON HAND INVENTORY	n
	HELD INVENTORY	n
	SAFETY STOCK	n
		F19 RETURN TO SELECT F24 END OF JOB

What to do

- To review or change a production family, type in the planning warehouse and production family number and press **Enter**. Go to display AML361.
- To specify options for what quantities are to be included when this production family is aggregated, accept the default of 1 to include the value, or type 2 to exclude the value, and press **Enter**. Go to display AML361.
- To assign an item to a production family with no members, type in the production family number and press **Enter**. The Display/Maintain Production Families display (AML361) appears with addition fields at the bottom of the display.
- To select another warehouse and production family number, use **F19**.
- To end the session, use **F24**.

Function keys

F19 RETURN TO SELECT displays the top portion of the display again so you can select another warehouse and production family number.

F24 END OF JOB ends processing and causes the Production Planning menu (AMLM10) to appear. The system ignores any information you typed on the display.

Fields

[\[?\]](#) appears next to a field name in the following field definitions to identify a field from which you can begin a master file search.

PLANNING WAREHOUSE [?]. Type the identifier of the warehouse you want to use.

ENTER PRODUCTION FAMILY NUMBER [?]. Type in the number of the production family to review, add to, change, or delete.

After you enter the production family number, the aggregation options fields appear: so you can change the values, if desired, to determine whether these quantities are to be included when this production family is aggregated, using option 1 on menu AMLM10.

ADJUSTED ON HAND INVENTORY. Accept the default of 1 to include the value, or type 2 to exclude the value in aggregation.

HELD INVENTORY. Accept the default of 1 to include the value, or type 2 to exclude the value in aggregation.

SAFETY STOCK. Accept the default of 1 to include the value, or type 2 to exclude the value in aggregation.

AML361—Display/Maintain Production Families

Use this display to show the master scheduled end items currently assigned to a production family, their percentage of contribution to the family, their priority in the family, and their scheduling dates. The display also lets you change the composition of a family, the quantity significance, and the rate per day. You also can specify override options to be used for an item in the production family.

Note: You must be authorized to the proper level of security in the warehouse you selected.

This display appears when you type in a valid production family number on the Display/Maintain Production Families Selection display (AML360) and press Enter.

```

DATE **/**/**      DISPLAY/MAINTAIN PRODUCTION FAMILIES      AML361 **
PROD FAMILY NUMBER *****      SIGNIFICANCE * *****
DESCRIPTION *****      RATE/DAY * ,***, ***
ITEM
SEQ      NUMBER      DESCRIPTION      PCT P      FROM      TO
** ***** ***** ***** ** * ***** *****

*****      INQUIRY  F05 CHG/DEL      F10 CHG RATE/SIG      F19 RETURN TO SELECT
*****      F08 ADD      F11 DELETE FAMILY      F24 END OF JOB

ITEM aaaaaaaaaaA15 ADDITION
PRIORITY A      SCHED FROM nnnnnn      SCHED TO nnnnnn      F03 RESUME INQ
INCL ON HAND A      HELD INV A      SAFETY STOCK A      F05 CHG/DELETE
Include options: 0=Use family 1=Include 2=Exclude

SEQ nn      SELECTION      F03 RESUME INQ
F08 ADD

ACTION A '1'-CHG '2'-DEL ITEM *****
PRIORITY A      SCHED FROM nnnnnn      SCHED TO nnnnnn      F03 RESUME INQ
INCL ON HAND A      HELD INV A      SAFETY STOCK A      F05 CHG/DELETE
Include options: 0=Use family 1=Include 2=Exclude

RATE/DAY nnnnnn      CHANGE RATE/SIGNIFICANCE
SIGNIFICANCE <K/M> A      F03 RESUME INQ

```

On this display, you can:

- Review all master scheduled end items assigned as members of a production family
- Review and change information about member items, including their scheduling dates and whether or not to include specific quantities for the item when aggregation is performed
- Add new members to a production family
- Delete one or all current members from a production family
- Change the quantity significance level for the family
- Change the production rate per day for the family.

The changes and additions you make on this display are effective as soon as you press Enter or use the appropriate function key. However, the system does not update the display during this session unless you use **F03** to see the Inquiry display again.

What to do

- To review more items assigned to this production family, press **Enter**. More items exist if CONTINUED appears in the lower left of the display.
- To add an item to this production family, use **F08**. Additional fields appear at the bottom of display AML361.
 - To add an item, type in the required information and press **Enter**.
 - To change or delete an item in this family, use **F05**. The **SEQ (Sequence)** field appears at the bottom of display AML361.
 - Type in the required information and press **Enter**. Type in action code 1 (change) and any information you want to change and press **Enter**. Type in action code 2 (delete) and press **Enter**. An informational message appears.
Note: To cancel the addition, change, or deletion, press any function key shown and do not press **Enter**.
 - To start the inquiry again and see any changes you made, use **F03**.
 - To add an item to this family, use **F08**.
 - To start another change or deletion, use **F05**.
- To change the rate per day or the quantity significance for this production family, use **F10**. Additional fields appear at the bottom of the display. Do one of the following:
 - To complete the change, type in the information you want to change and press **Enter**.
 - To start the inquiry again without completing the change, use **F03**.
- To override the aggregation options for an item, use **F05**. Additional fields appear at the bottom of the display. Do one of the following:
 - To complete the change, type in the information you want to change and press **Enter**.
 - To start the inquiry again without completing the change, use **F03**.

- To delete all items from this production family, use **F11**. An advisory message appears at the bottom of display AML361. Do one of the following:
 - To complete the deletion, use **F11**. Go to display AML360.
Note: To cancel the deletion, press any other function key shown or **Enter** and do not use **F11**.
 - To review more members in this family, press **Enter**. More members exist if CONTINUED appears in the lower left of the display.
 - To add an item to this family, use **F08** (refer to previous discussion for details).
 - To change or delete a member in this family, use **F05** (refer to previous discussion for details).
 - To change the rate per day or the quantity significance for this family, use **F10** (refer to previous discussion for details).
 - To review a different family, use **F19** and go to display AML360.
 - To end this session, use **F24**.
- To review the items assigned to another production family, use **F19** and go to display AML360.
- To end the session, use **F24**.

Function keys

F03 RESUME INQ (Resume Inquiry) causes display AML361 to appear again with the body updated to show any changes you made. This function key does not appear when the display is in Inquiry mode.

F05 CHG/DEL (Change/Delete) the **SEQ (Sequence Number)** field to appear at the bottom of the display. Type in the sequence number of the item to change or delete, and press **Enter**. Additional fields appear at the bottom of the display. The number of the item you selected and current information about the item appear in the fields for you to review or change.

F08 ADD causes entry fields to appear at the bottom of the display so that you can assign a master scheduled item to this production family:

F10 CHG RATE/SIG (Change Rate Per Day/Quantity Significance) causes entry fields to appear at the bottom of the display. You can use them to change the rate per day and the quantity significance for this production family.

RATE/DAY (PFCAP). Type in a new production rate per day for this production family. If this family uses quantity significance, you must use that significance when you type in the rate per day quantity.

Note: The quantity significance for the family affects how the system shows the rate per day. If you change the quantity significance for the family, enter the rate per day again using the new significance.

SIGNIFICANCE <K/M> (PFSIG). Type in the one-letter code that identifies the quantity significance to use for this production family. The quantity significance determines how many digits are shown or printed in quantity fields on production planning displays and reports.

The codes are:

blank System shows or prints all digits (the full quantity).

K System does not show or print the last three digits (000). Multiply by 1,000 for the actual quantity.

M System does not show or print the last six digits (000,000). Multiply by 1,000,000 for the actual quantity.

After you press **Enter**, display AML361 appears again in Inquiry mode with all fields updated.

F11 DELETE FAMILY deletes all members from this production family. An informational message appears. Use **F11** again to complete the deletion, or use any other function key or **Enter** to cancel the deletion. If you complete the deletion, the Selection display (AML360) appears. If you cancel the deletion, the function key you use determines which display appears next.

F19 RETURN TO SELECT causes the Display/Maintain Production Families Selection display (AML360) to appear. This function key does not appear when the display is in INQUIRY mode.

F24 END OF JOB ends processing and causes the Production Planning menu (AMLM10) to appear.

Fields

[\[?\]](#) appears next to a field name in the following field definitions to identify a field from which you can begin a master file search.

PROD FAMILY NUMBER (PFNBR). The number of the production family whose members you are reviewing. This is the number you typed in on display AML360.

SIGNIFICANCE (Quantity Significance) (PFSIG). The one-letter quantity significance code you assigned to this production family and the number of field positions (digits) the quantity fields are shortened on production planning displays and reports.

This method of shortening quantities makes them easier to read and adjusts very large quantities that exceed the length of the fields in which they appear.

You see one of the following in this field:

() System shows all digits (the full quantity).

K (000) System does not show the last three digits (000). Multiply by 1,000 for the actual quantity.

M (000,000) System does not show the last six digits (000,000). Multiply by 1,000,000 for the actual quantity.

For example, if the quantity significance for a production family is (000), the quantity 2,795 is actually 2,795,000.

Note: A high quantity significance can cause small quantities not to appear. For example, a quantity of 300 does not appear if the quantity significance code is K (does not show last three digits). If a quantity is too small to appear, the field shows a zero.

You set the quantity significance for each production family. When you enter a quantity for the family's operating plan, you must use the quantity significance you assigned to that family. For consistency, you should use the same quantity significance for as many families as possible.

DESCRIPTION (ITDSC). A description of the production family.

Note: The following two fields appear as display fields. However, you can change them on this display using **F10**.

RATE/DAY (Rate per Day) (PFCAP). The total production per day for this family. This quantity is the total of daily production rates for its member items. The quantity can show maximum production rates or desired rates. It is used to calculate the maximum (or desired) target for the family per period.

Note: The quantity significance for the family affects this field. If you change the quantity significance for the family, enter the rate per day for the family again using the new significance.

If CONTINUED appears in the lower left of the display, more information exists than can appear at one time. Press **Enter** to see the next set.

The fields shown in the body of the display are for information only; you cannot change them by typing over them. To add, change, or delete items in the family or change the rate per day or the significance for the family, you must use the function keys at the bottom of the display.

SEQ (Sequence Number). A system-generated number that you can use to identify an item to change or delete.

ITEM NUMBER (PFITM). The number of a master scheduled item assigned to this production family.

Note: Only master scheduled end items can be assigned to production families.

DESCRIPTION (ITDSC). A description of the master scheduled item.

PCT (Percentage) (PFPCT). The percentage of total blended demand for the family contributed by this item. The system recalculates this percentage each time you aggregate.

P (Priority) (PFPTY). The priority level you assigned to this item based on its importance. The priority level controls which items you see first when you review a production family or review items by family. The value ranges can be numeric (0 to 9) or alphabetic (A to Z), or both (the default is 9).

Note: A is the highest alphabetic priority; 0 is the highest numeric priority. Use those priorities for the items you want to see first. If you use both alphabetic and numeric characters to indicate priority, all alphabetic priorities appear before any numeric priority.

SCHEDULED FROM (PFDFM). The date this item becomes available for production scheduling. From this date the item is included in the family's resource profile and in aggregated family totals.

SCHEDULED TO (PFDTO). The last date for including this item in production schedules. After this date the item is not included in the family's resource profile or in aggregated family totals.

Note: The scheduling dates become effective the next time you generate resource profiles or aggregate. If you are phasing items into and out of production, it is important to generate new resource profiles and to aggregate family information so that resource testing and production planning activities use the new family structures.

ACTION. Type in 1 (change) to change information about an item. Type in 2 (delete) to delete an item from the family. If you type in 1, you can type new information into the **PRIORITY**, **SCHED** and **INCLUDE** fields. If you type in 2, the system ignores any information you type in, and a message tells you to press Enter to delete the item.

ITEM (PFITM). The number of the master scheduled item to change or delete. This number is for information only.

PRIORITY (PFPTY). Type in a new priority number or letter for this item, based on its importance. The priority level controls the items you see first when you review a production family or review items by family. The value ranges can be numeric (0 to 9) or alphabetic (A to Z), or both (the default is 9).

Note: A is the highest alphabetic priority; 0 is the highest numeric priority. Use those priorities for the items you want to see first. If you use both alphabetic characters and numeric digits to indicate priority, all alphabetic priorities appear before any numeric priority.

SCHED FROM (Scheduled From) (PFDFM). Type in a new start date for including this item in production scheduling and in family-level calculations.

SCHED TO (Scheduled To) (PFDTO). Type in a new date after which this item is not scheduled for production or included in family-level calculations.

ITEM (PFITM) [?]. Type in the number of the master scheduled item to assign to this family.

Note: Any item you assign to a production family should be a master scheduled end item and should use production plans as its demand source for master scheduling. If the item you type in does not fit those conditions, an informational message reminds you to code the item as master scheduled (master scheduled item code = M) and as production planned (MPS planning source code = P) in the Item Master file.

PRIORITY (PFPTY). Type in a priority value for this item, based on its importance. The priority level controls the items you see first when you review a production family or review items by family. The value ranges can be numeric (0 to 9) or alphabetical (A to Z), or both (the default is 9).

Note: A is the highest alphabetic priority; 0 is the highest numeric priority. Use those priorities for the items you want to see first. If you use both alphabetic characters and numeric digits to indicate priority, all alphabetic priorities appear before any numeric priority.

INCL (Include) ON HAND. Type one of the following values to specify how aggregation for this item in the production family is to be performed, regardless of the options specified for the production family on display AML360:

- 0** Use the value for the production family as entered on display AML360. This is the default.
- 1** Include this value in aggregation.
- 2** Do not include this value in aggregation.

(Include) HELD INV. Type one of the following values to specify how aggregation for this item in the production family is to be performed, regardless of the options specified for the production family on display AML360:

- 0** Use the value for the production family as entered on display AML360. This is the default.
- 1** Include this value in aggregation.
- 2** Do not include this value in aggregation.

(Include) SAFETY STOCK. Type one of the following values to specify how aggregation for this item in the production family is to be performed, regardless of the options specified for the production family on display AML360:

- 0** Use the value for the production family as entered on display AML360. This is the default.
- 1** Include this value in aggregation.
- 2** Do not include this value in aggregation.

Chapter 4. Master Schedule Planning

When you select option 2 on the Main Menu (AMLM00), the Master Schedule Planning secondary menu (AMLM20) appears.

Option 1. Generate Master Schedules (AMLM20)	4-4
Option 2. Display and Maintain Master Schedule (AMLM20)	4-14
Option 3. Test Master Schedule Resources (AMLM20)	4-46
Option 4. Display Resource Requirements (AMLM20)	4-50
Option 5. Master Schedule Planning Report (AMLM20)	4-58
Option 6. Available to Promise (AMLM20)	4-63
Option 7. Item Requirements Inquiry (AMLM20).....	4-71

If EPDM is activated, a master file search is available to allow you to search for items in the Item Revision Master file.

If you do not use Forecasting (FCST) or Customer Order Management (COM), it is your responsibility to be sure that the forecast and customer order information in the Demand Interface file is accurate and up to date.

```
AML20                Master Production Schedule Planning          *****
                    Master Schedule Planning

Type option or command; press Enter.

  1. Generate Master Schedules
  2. Display and Maintain Master Schedule
  3. Test Master Schedule Resources
  4. Display Resource Requirements
  5. Master Schedule Planning Report
  6. Available to Promise
  7. MRP Item Inquiry

==> _____

F3=Exit      F4=Prompt   F9=Retrieve  F10=Actions
F11=Job status F12=Return  F22=Messages
```

Option 1. Generate Master Schedules. Use this option to plan orders and project inventory balances for all master scheduled items at the product structure levels you specify. This option can be performed for an individual planning warehouse or for a range of planning warehouses. The Planning Run Status display (AML411) lets you run the job from your work station or put it in the job queue.

Generate Master Schedules can run interactively or as a batch process. The processing can take considerable time, depending on such factors as:

- How many product structure levels you plan
- How many master scheduled items you have
- Whether you extract new demand information as part of the generation (planning run).

You should schedule the master schedule generation to minimize your waiting time and to avoid delaying other long-running jobs.

Before you generate master schedules (option 1), be sure that the following information is up to date:

- Forecasts
- Customer orders
- Inventory
- Production plans (if you use them as a source of demand for master scheduling)
- MLI requirements in MRP for the parents of any master-scheduled component items.

Option 2. Display and Maintain Master Schedule. Use this option to review master schedules for one or a series of items within a selected planning warehouse and make any necessary changes. Exception codes identify orders that need special attention. On the Blended Demand display (AML454) you can see by period the forecasts and customer orders contributing to the demand for the item.

Option 3. Test Master Schedule Resources. Use this option to calculate the quantity and value of the critical resources within a selected planning warehouse needed to meet your master production schedules. This process is also called rough-cut capacity planning.

Test Master Schedule Resources is another batch job. Like master schedule generation, it can take considerable processing time. Schedule it to minimize your waiting time and to avoid conflict with other batch processes.

Option 4. Display Resource Requirements. Use this option to review, by planning warehouse and by period, the quantity and value of a critical resource needed to meet your master schedules. You can also see details about the orders that are contributing to the use of that resource in a specific period.

Option 5. Master Schedule Planning Report. Use this option to have the Master Schedule Planning Report printed for the master production schedules for all items, within the planning warehouse range selected, assigned to one or more planners or production families. The report includes brief exception messages for orders that need special attention. It shows current inventory and order status information.

Option 6. Available to Promise. Use this option to show you by period the projected quantities of an item within a selected planning warehouse that are available to sell or use. The calculation uses current inventory and open order information.

Option 7. MRP Item Inquiry. Use this option to use the Item Inquiry displays in MRP to look at peg-to relationships for master scheduled component items for the planning warehouse and planner selected.

Option 1. Generate Master Schedules (AML20)

Use this option to select an individual planning warehouse or range of planning warehouses and to set planning limits for a master schedule generation (planning run) and start the planning run. Before you start the planning run, you can review the dates you set for the planning run and review planning conditions from the last planning run.

Note: You cannot change the dates for the next planning run using this option. To change the dates, you must return to the Main Menu (AML00) and select option 5, Change/Display Horizon Dates.

What information you need:

- The planning warehouses in which you want to generate master schedules
- The product structure levels with master scheduled items for which you want to plan orders
- The product structure levels with master scheduled items for which you want to extract (gather) current demand information for planning orders.

What report is printed:

Planning Run Status Report (AML480).

What forms you need: None.

The basic steps to generate master schedules follow each display.

AMV3HH—Generate Master Schedules

Use this display to select in which planning warehouses master schedules will be generated. You can select a single planning warehouse, or a range of planning warehouses. For each warehouse that falls in the range selected, separate jobs are initiated and separate reports are printed.

Note: You must be authorized to the proper level of security in the warehouses you select.

This display appears when you select option 1 on menu AMLM20.

For the **From** and **To** ranges on this display, the value you type in the **To** field must be greater than or equal to the value you type in the **From** field when both fields are used. The range begins with and includes the value you type in the **From** field; it ends with and includes the value you type in the **To** field.

If you type a value in the **From** field only, the system ends the range with the highest value for that field. If you type a value in the **To** field only, the system begins the range with the lowest value for that field. If you want to select records by a single value instead of a range, use that value in both the **From** and **To** fields.

```
AMV3HH                                Generate Master Schedules

Planning warehouse limits
From warehouse . . . . . aA3
To warehouse . . . . . aA3

F1=Help      F5=Refresh      F24=Cancel
```

What to do

- To proceed, select a range of planning warehouses and press **Enter**. Display AML410 appears.
- To cancel the session, use **F24**. Menu AMLM20 appears again.

Function keys

F5=Refresh restores the display to its status before you made any changes.

F24=Cancel ends processing and any data you typed is ignored. The Master Schedule Planning menu (AMLM20) appears again.

Contents	Index	Exit
--------------------------	-----------------------	----------------------

Fields

[\[?\]](#) appears next to a field name in the following field definitions to identify a field from which you can begin a master file search.

Planning warehouse limits.

From warehouse/To warehouse [?]: The range of warehouses to use for this task.

AML410—Generate Master Schedules Planning Run Options

Use this display to show the horizon dates which are used for this master production schedule generation (planning run), the earliest dates for information in the Demand Interface file and the Item Production Plan file (if you use them), and the planning status of the last planning run. This display also lets you set the planning limits for this planning run for the selected planning warehouses.

This display appears when you press **Enter** on display AMV3HH.

The information appears for the first warehouse in the range of warehouses you selected. After you enter information for that warehouse on this display, a second display (AML411) appears for you to verify the planning limits, select interactive or batch processing, and start the job. When you press **Enter** on that display, a third display (AML413) appears where you can select a specific date and time to start the planning run.

When you press **Enter** on display AML413, this display appears again with the information for the next warehouse in the range of warehouses you selected.

```

DATE **/**/**          GENERATE MASTER SCHEDULES          AML410  **
                        PLANNING RUN OPTIONS

                        PLANNING STATUS

MPS START DATE         **/**/**          LOWEST LEVEL PLANNED      ****
MPS CURRENT DATE       **/**/**          LOWEST LEVEL EXTRACTED   ****
MPS CUTOFF DATE        **/**/**          LAST EXTRACTION DATE     **/**/**
PROD PLAN FILE DATE    **/**/**          NEXT LEVEL TO PLAN       **
DEMAND FILE DATE       **/**/**

                        PLANNING WAREHOUSE          ***

                        PLAN ORDERS TO THIS LEVEL   nn

                        EXTRACT <Y/N>              A
                        EXTRACT TO THIS LEVEL       nn

                        PLAN ORDERS IN CMLT <Y,N>   A

                                                    F24 END OF JOB
    
```

What to do

The dates that the system uses for this planning run and the limits used for the last planning run for the selected warehouse are shown in the upper part of the display. Do one of the following:

- To start a planning run for the selected warehouse, type in the requested information and press **Enter**. Go to display AML411.
- To end the session without starting a planning run, use **F24**.

Function keys

F24 END OF JOB ends processing and causes the Master Schedule Planning menu (AMLM20) to appear. The system ignores any information you typed on the display.

Fields

The fields on the upper half of the display are for review only. They show information for the selected planning warehouse about the planning dates for this planning run, extraction and planning limits used in the last planning run, entries in the Demand Interface and Item Production Plan files (if you use those files), and the product structure level at which planning may begin for this planning run. You cannot change any of these fields on this display.

PLANNING STATUS. The fields on the left show the dates that are used for this planning run if you do not change them on display AML601 before starting the planning run. If you did not change the master scheduling horizon dates after the last planning run, these dates (except for demand file date and production plan file date) are the horizon dates used in the last planning run. If you did change them, the system highlights them and issues an informational message.

Note: If the first three fields (**MPS START DATE**, **MPS CURRENT DATE**, and **MPS CUTOFF DATE**) have changed since the last planning run, they are highlighted.

MPS START DATE (MPST): . The first day of the master scheduling horizon. This date is back-dated from the MPS (master production schedule) Current Date using the number of overdue work days (OVLGH) set in Material Requirements Planning. For example, if the number of overdue days is six, the start date is six work days earlier than the MPS Current Date.

MPS CURRENT DATE (MPCU): . The date that identifies the current period in the master scheduling horizon. The MPS Current Date is also a reference date for coordinating the production schedules in MPSP and MRP. When the MRP Current Date is the same as the MPS Current Date, the component orders planned in MRP align exactly with the master scheduled orders transferred from MPSP.

MPS CUTOFF DATE (MPCO): . The last day in the master scheduling horizon. No orders are planned for periods after this date.

PROD PLAN FILE DATE . is the earliest period beginning date in the Item Production Plan file. This date is set each time you replace all item production plans. The date is a period beginning date.

DEMAND FILE DATE (FDPD): . The date of the first period containing forecasts or customer orders in the Demand Interface file. This date must be the first day of the week for the first week in a period. If you use methods other than MAPICS XA Forecasting to put information into this file, see Appendix B in this manual for more information about loading the file.

LOWEST LEVEL PLANNED (LLPL): . The number of the lowest product structure level for which you planned orders in the previous planning run. If the planning run is interrupted and no orders are planned, the field shows NONE.

Contents	Index	Exit
-----------------	--------------	-------------

LOWEST LEVEL EXTRACTED (EXLL): The number of the lowest level for which you extracted (gathered) current demand information in the previous planning run. If the extraction is interrupted and no information is extracted for any level, the field shows NONE.

Note: If this field shows NONE, you must extract in the next planning run.

LAST EXTRACTION DATE (PXDT): The date when you last extracted (gathered) demand information to use for generating master production schedules.

NEXT LEVEL TO PLAN (LLAC): The number of the product structure level at which the system begins planning orders for master scheduled items in this planning run. Usually, the system begins at the highest product structure level on which you changed a master production schedule. However, if you extract or if certain other conditions occur, the system ignores this level and begins planning at level zero. See "AML411—Generate Master Schedules Planning Run Status" for a list of the special conditions.

PLANNING WAREHOUSE. The first and succeeding planning warehouses you selected on display AMV3HH.

Use the following fields to control the scope and the processing time for this planning run for the selected planning warehouse. You can plan or replan orders for one or more levels at a time. The more levels you plan, the more processing time is needed. You can choose not to extract when you are replanning within a few days after the last extraction or when you know that demand information has not changed significantly. Extracting provides current information but requires more processing time. It also requires that you submit the job to the job queue; you cannot perform the planning run interactively when you extract.

You can plan and maintain your master production schedules level by level. You can plan orders for one level (for example, level zero), review and maintain the schedules at that level, and then plan orders for the next lower level (in this example, level one), so that the orders reflect the changes you made in level zero items.

PLAN ORDERS TO THIS LEVEL. Required. Type in the number of the lowest product structure level of master scheduled items for which you want to plan orders.

Note: If you extract new information for this planning run, be sure that this number is smaller than or equal to the number you type in for **EXTRACT TO THIS LEVEL**. If you do not extract new information, be sure that this number is smaller than or equal to the number shown for **LOWEST LEVEL EXTRACTED**.

EXTRACT <Y/N>. Type **Y** in this field to extract current demand information in this planning run. Type **N** in this field to use previously gathered information to plan orders in this planning run.

Note: If you are generating new master production schedules for all levels, or if customer orders, forecasts, or other demand information has changed significantly since the last planning run, you should extract so that all orders are based on current information.

If Y appears in the field, extraction is suggested or required. See the messages at the bottom of the display to identify the special conditions and decide on your action. If extraction is not required, you can type in **N** and generate orders without extracting.

Contents	Index	Exit
--------------------------	-----------------------	----------------------

EXTRACT TO THIS LEVEL. If you are extracting (EXTRACT = Y), type in the number of the lowest product structure level for which you want to gather current demand information. Usually you want to extract to the lowest level where master scheduled items exist.

You do not need to extract each time you plan orders or extract only for the levels you plan orders for in this planning run. You can extract for all levels at one time; then you can plan and maintain or replan orders one level at a time.

Note: If you type **N** for **EXTRACT**, do not type anything in this field. If you type **Y** or the system puts Y for **EXTRACT**, this field is required. Be sure that the number in this field is as large as the number for **PLAN ORDERS TO THIS LEVEL**. The default for this field is the number of the lowest product structure level where master scheduled items exist.

PLAN ORDERS IN CMLT (Cumulative Material Lead Time) <Y/N>. Type **Y** to have orders planned on the date required. Type **N** to have any order that would be planned within the CMLT to be planned at the CMLT time fence (at the end of the item CMLT), and marked with an exception code of F to indicate that it has been deferred to this date. The default is the option previously selected for this warehouse in the PLNINF file.

AML411—Generate Master Schedules Planning Run Status

Use this display to show the number of product structure levels for which the system extracts new demand information for the selected planning warehouse. It also shows the first and last product structure levels for which the system plans orders. On this display, you can start the planning run as an interactive job at your work station or as a batch job.

This display appears when you press **Enter** on the Generate Master Schedules Planning Run Options display (AML410). The fields on this display are for information only. To change them, you must end the job and select option 1, Generate Master Schedules, again on the Master Schedule Planning menu (AMLM20).

DATE	**/**/**	GENERATE MASTER SCHEDULES PLANNING RUN STATUS	AML411 MA
		PLANNING WAREHOUSE	***
		NUMBER OF LEVELS TO EXTRACT	**
		PLANNING WILL BEGIN AT LEVEL	**
		PLANNING WILL STOP AFTER LEVEL	**
		ORDERS PLANNED WITHIN CMLT	***
			F24 END OF JOB

What to do

- To start this planning run as an interactive job from your work station, use **F09**. An interactive display appears and remains until the interactive run is complete. When the planning run ends, go to menu AMLM20.

Note: If you are extracting during this planning run (EXTRACT=Y on display AML410), or more than one planning warehouse was selected on display AMV3HH, **F09** does not appear on this display. You must start the planning run as a batch job.

- To start this planning run as a batch job and free your work station for other activities, press **Enter**. The system submits the job to the job queue.
- To end the session without starting a planning run, use **F24**.

Function keys

F09 RUN JOB NOW starts the master production schedule generation (planning run) as an interactive job from your work station. You cannot begin another task from your work station until the planning run is complete. When the job ends, the Master Schedule Planning menu (AMLM20) appears.

Note: Use **F09** to run jobs that do not require much processing time. The information on display AML410 and on this display can help you estimate how much time the system needs to complete the planning run with the limits you set. Important factors include:

- The number of levels to be planned
- The number of master scheduled items at each level.

If one of those factors is large, you may prefer to perform the planning run as a batch job. To do that, press **Enter**.

If you are extracting (EXTRACT=Y on display AML410) in this planning run, **F09** does not appear on this display, and you must start the planning run as a batch job.

F24 END OF JOB ends processing and causes the Master Schedule Planning menu (AMLM20) to appear. The system cancels the planning run.

Fields

PLANNING WAREHOUSE. The planning warehouse you selected on the previous display.

NUMBER OF LEVELS TO EXTRACT. The number of product structure levels for which the system extracts new demand information in this planning run. This number results from the extraction level you specify (**EXTRACT TO THIS LEVEL**) on display AML410. If you are not extracting (EXTRACT=N on display AML410), this number is 0.

Note: This number is usually one larger than the lowest level to be extracted because level zero is the first level extracted. For example, if you extract to level two, you extract levels zero, one, and two, and this field shows three levels to extract.

PLANNING WILL BEGIN AT LEVEL. The first product structure level for which the system plans orders in this planning run. This level is the same as **NEXT LEVEL TO PLAN** on display AML410 unless:

- You are extracting (EXTRACT=Y on display AML410). If you extract, planning begins at level zero.
- On display AML410 you entered a number for **PLAN ORDERS TO THIS LEVEL** that was smaller than the number for **NEXT LEVEL TO PLAN**. If you did, the system ignores **NEXT LEVEL TO PLAN**, begins planning at level zero, and stops planning at the level you specified.

PLANNING WILL STOP AFTER LEVEL. The lowest product structure level for which the system plans orders in this planning run. This number is the number you typed for **PLAN ORDERS TO THIS LEVEL** on display AML410. The system deletes planned orders for all levels lower than the one shown.

PLAN ORDERS WITHIN CMLT. Yes or No appears according to your selection on display AML410 to indicate how orders are to be planned in this planning run.

AML413—Generate Master Schedules Planning Run Submit

Use this display to start the master schedule generation for the selected planning warehouse.

This display appears when you press **Enter** on display AML411.

If you selected a range of planning warehouses on the selection display (AMV3HH), when you press **Enter** here display AML410 appears with information for the next planning warehouse in the range.

```
DATE  **/**/**          GENERATE MASTER SCHEDULES          AML413  **
                          PLANNING RUN SUBMIT

You can select a specific date and time
to start the planning run.

To start the planning run now,
press ENTER.

To start the planning run later,
enter a date and time:

          DATE  nnnnnn
          TIME  nnnnnn

                                F18 REFRESH
                                F24 END OF JOB
```

What to do

- To start the master schedule generation, accept the defaults or type in the date and time you want the job to start.
- To end the session without starting a planning run, use **F24**.

Function keys

F18 REFRESH restores the display to its status before you made any changes.

F24 END OF JOB ends processing and causes the Master Schedule Planning menu (AMLM20) to appear. The system cancels the planning run.

Fields

DATE. Accept the default of the current system date or type in the date you want to start the job.

TIME. Accept the default of the current system time or type in the time you want to start the job.

Option 2. Display and Maintain Master Schedule (AMLM20)

Use this option to:

- Review information about a master production schedule
- Add, change, cancel, or firm an order for a master scheduled item
- See detailed information about blended demand for an item.

Note: You must be authorized to the proper level of security in the warehouses you select.

What information you need: The item number for the item you want to review, or, if you want to review items by planner or family, the number of a planner or production family and the planning warehouse in which the item/planner/family exists.

What report is printed: Master Schedule Open Order Maintenance List (AML455).

What forms you need: None.

The basic steps to display and maintain master schedules follow each display.

AML450—Display/Maintain Master Schedule Planner/Family Selection

Use this display to select a sequence and starting point for reviewing master production schedules. It also lets you limit the review to schedules with exception conditions or schedules you have not already reviewed.

This display appears when you select option 2 on the Master Schedule Planning menu (AMLM20). It also appears when you:

- Use **F01 RESTART** on AML451, AML452, or AML453
- Use **F06 NEXT ITEM** or **F10 SET BYPASS** on display AML452 or AML453 and the planner or family number changes. The number can change because:
 - No more planners or families exist in the sequence you selected.
 - No more items exist for the planner or family you were reviewing.

```

DATE  **/**/**          DISPLAY/MAINTAIN MASTER SCHEDULE
                          PLANNER/FAMILY SELECTION          AML450  **

SELECT PLANNER/FAMILY SEQUENCE <P/F>          A
BYPASS ITEMS ALREADY REVIEWED <Y/N>          A
SELECT ITEMS TO INCLUDE                          n
  1 ALL
  2 EXCEPTIONS ONLY
  3 EXCEPTIONS OF EXPEDITE, RESCHEDULE,
    AND DEFER ONLY

F02 RESTART-ITEM
F24 END OF JOB
    
```

What to do

- To review master schedules for items assigned to a planner, type in the required information and press **Enter**. Go to display AML45P.
- To review master schedules for items assigned to a production family, type in the required information and press **Enter**. Go to display AML45F.
- To review the master schedule for a specific item, use **F02** and go to display AML451.
- To end the session, use **F24**.

Function keys

F02 RESTART-ITEM causes the Display/Maintain Master Schedule Item Selection display (AML451) to appear. You can use that display to review the master schedule for a specific item. The system does not process any information you typed on the display.

F24 END OF JOB ends processing and causes the Master Schedule Planning menu (AMLM20) to appear. The system ignores any information you typed on the display. It also prints the Master Schedule Open Orders Maintenance List (AML455) if you changed any open orders.

Fields

[\[?\]](#) appears next to a field name in the following field definitions to identify a field from which you can begin a master file search.

SELECT PLANNER/FAMILY SEQUENCE <P/F>. Type in **P** (planner) in this field to review master schedules for items assigned to the planner you select. Type in **F** (production family) to review master schedules for items assigned to the production family you select.

BYPASS ITEMS ALREADY REVIEWED <Y/N>. Type in **Y** to see schedules only for items that you have not marked with **F10** on displays AML452 or AML453 since the last MPSP planning run. Type in **N** to see schedules for all items, whether marked or not. Y is the default.

SELECT ITEMS TO INCLUDE. Type in the number for the type of item you want to review schedules for:

- 1** ALL. Shows master schedules for all items assigned to the planners or families you specified. 1 is the default.
- 2** EXCEPTIONS ONLY. Shows master schedules for items only if the items have orders with exception messages.
- 3** EXCEPTIONS OF EXPEDITE, RESCHEDULE AND DEFER ONLY. Shows master schedules for items only if the items have orders or requisitions with expedite, reschedule or defer exception messages.

AML45P—Display/Maintain Master Schedule Planner Selection

Use this display to select the planning warehouse and planner whose master schedules you want to review.

This display appears when you select P and press **Enter** on display AML450.

DATE	**/**/**	DISPLAY/MAINTAIN MASTER SCHEDULE PLANNER SELECTION	AML45P MB
PLANNING WAREHOUSE	aA3		
PLANNER NUMBER	nnnn		
STARTING LEVEL	nn		
STARTING ITEM	aaaaaaaaaaaA15		
			F01 RESTART F24 END OF JOB

What to do

- To review master schedules for a specific planning warehouse/planner, type in the required information and press **Enter**. Go to display AML452 or AML453.
Note: For a production planned item, display AML452 appears; for any other item, display AML453 appears. Your actions are the same for either display.
- To end the session, use **F24**.

Function keys

F01 RESTART causes the Display/Maintain Master Schedule Selection display (AML450) to appear. The system does not process any information you typed on the display.

F24 END OF JOB ends processing and causes the Master Schedule Planning menu (AMLM20) to appear. The system ignores any information you typed on the display. It also prints the Master Schedule Open Orders Maintenance List (AML455) if you changed any open orders.

Fields

[\[?\]](#) appears next to a field name in the following field definitions to identify a field from which you can begin a master file search.

PLANNING WAREHOUSE [?]. Required. Type the planning warehouse identifier for which you want to review master schedules.

PLANNER NUMBER. Optional. Type in the number of the first planner whose master schedules you want to review. The default is the lowest-numbered planner.

STARTING LEVEL. Optional. Type in the number of the first product structure level with items you want to review. Master schedules appear for items at this structure level and all lower levels. The default is level zero.

STARTING ITEM [?]. Optional. Type in the number of the first item you want to review for the planning warehouse/planner and at the level you specified. If the item is not master scheduled in the planning warehouse you selected, the system shows you the next higher-numbered item assigned to that planning warehouse/planner on the level you specified.

AML45F—Display/Maintain Master Schedule Family Selection

Use this display to select the starting production family and planning warehouse whose master schedules you want to review.

This display appears when you select F and press **Enter** on display AML450.

DATE	**/**/**	DISPLAY/MAINTAIN MASTER SCHEDULE FAMILY SELECTION	AML45F	**
PLANNING WAREHOUSE		aA3		
STARTING FAMILY NUMBER		aaaaaaaaaaaaA15		
F01 RESTART F24 END OF JOB				

What to do

- To review master schedules for a specific planning warehouse/family, type in the required information and press **Enter**. Go to display AML452 or AML453.

Note: For a production planned item, display AML452 appears; for any other item, display AML453 appears. Your actions are the same for either display.

- To end the session, use **F24**.

Function keys

F01 RESTART causes the Display/Maintain Master Schedule Selection display (AML450) to appear. The system does not process any information you typed on the display.

F24 END OF JOB ends processing and causes the Master Schedule Planning menu (AMLM20) to appear. The system ignores any information you typed on the display. It also prints the Master Schedule Open Orders Maintenance List (AML455) if you changed any open orders.

Fields

[?] appears next to a field name in the following field definitions to identify a field from which you can begin a master file search.

Contents	Index	Exit
--------------------------	-----------------------	----------------------

STARTING FAMILY NUMBER. Optional. Type in the number of the first production family that includes master scheduled items you want to review. The default is the lowest-numbered production family.

PLANNING WAREHOUSE [?]. Required. Type the planning warehouse identifier for which you want to review master schedules.

AML451—Display/Maintain Master Schedule—Item Selection

Use this display to select a planning warehouse and a specific item whose master schedule you want to review.

This display appears when you use **F02 RESTART-ITEM** on the Planner/Family Selection display (AML450) or on the Display/Maintain Master Schedule displays (AML452 and AML453).

```

DATE **/**/**          DISPLAY/MAINTAIN MASTER SCHEDULE          AML451  **
                        ITEM SELECTION

                        PLANNING WAREHOUSE  aA3
                        ENTER ITEM NUMBER   aaaaaaaaaaaaA15

                                                    F01 RESTART
                                                    F24 END OF JOB
    
```

What to do

- Type in the number of the master scheduled item and its planning warehouse you want to review and press **Enter**. Go to display AML452 or AML453.

Note: For a production planned item, display AML452 appears; for any other item, display AML453 appears. Your actions are the same for either display.

- To review master schedules for items assigned to a planner or a production family, use **F01**. Go to display AML450.
- To end the session, use **F24**.

Function keys

F01 RESTART causes the Display/Maintain Master Schedule Planner/Family Selection display to appear. The system does not process any information you typed on the display.

F24 END OF JOB ends processing and causes the Master Schedule Planning menu (AML20) to appear. The system ignores any information you typed on the display. It also prints the Master Schedule Open Orders Maintenance List (AML455) if you changed any open orders.

Contents	Index	Exit
--------------------------	-----------------------	----------------------

Fields

[\[?\]](#) appears next to a field name in the following field definitions to identify a field from which you can begin a master file search.

ENTER ITEM NUMBER [?]. Type in the number of the master scheduled item whose master production schedule you want to review.

PLANNING WAREHOUSE [?]. Type in the number of the planning warehouse in which you want to review the selected item's master schedule.

Contents	Index	Exit
--------------------------	-----------------------	----------------------

AML452—Display/Maintain Master Schedule—Production Plan

Use this display to show all manufacturing orders, purchase orders, schedules, and requisitions within a planning warehouse for a master scheduled item that is production planned. It also shows supporting information about demand, inventory levels, order policies, and manufacturing time limits. This display lets you change the orders you see or add new ones.

Note: You must be authorized to the proper level of security in the warehouse you select.

This display appears when the item you are reviewing uses a production plan as its demand source. If the item uses any other demand source, display AML453 appears.

This display, with AML453, lets you review and adjust the order schedule for a master scheduled item before MRP uses those orders to plan orders for components. While you are reviewing, informational messages appear if the next item exists on a lower product structure level or was not planned during the last planning run.

Depending on the function keys or action codes you select, additional footers appear at the bottom of the display.

On this display, you can:

- Review open, firm planned, and planned orders for a master scheduled item
- Add firm planned orders to cover unexpected demand
- Change due dates, quantities, start dates, and order types for open, firm planned, and planned orders
- Cancel open, firm planned, and planned orders

Note: To change or cancel an open order, you must repeat the changes that you made in MPSP using open order maintenance. You can maintain open orders through Inventory Management, or through Purchasing, if installed and interfacing. The application prints the Master Schedule Open Order Maintenance List (AML455) to help you make the changes.

- Change planned orders to firm planned orders
- Compare scheduled orders with current demand patterns and inventory projections
- See the relation of orders to Demand and CMLT time limits for the item
- Return to a Selection display to change the sequence of items (AML450) or the specific item (AML451) you are reviewing
- Look at a supporting display (Blended Demand, AML454) for details about the BLEND DMD column
- Identify items to not review again before the next master schedule generation.

Contents	Index	Exit
--------------------------	-----------------------	----------------------

```

ADDITION *****
ALT BOM ID ***** REV ***** ROUTING ID ***** VERSION
                                           F13 SELECT PROCESS

CHANGE ORIG-DUE ***** QTY ***** START ***** TYPE * F03 RESUME INQ
NEW          nnnnnn   nnnnnnn.nnn  nnnnnn   A   F05 CHG/CNL
                                           F08 ADD

CHANGE *****
ALT BOM ID ***** REV ***** ROUTING ID ***** VERSION
*****
                                           F13 SELECT PRO
    
```

What to do

For a production planned item, display AML452 appears; for any other item, display AML453 appears. Your actions are the same for either display.

Do one of the following:

- To review more orders for this item, press **Enter**. More orders exist if CONTINUED appears in the lower left of the display.
- To review orders for this item starting at a specific date, type the date into the **PAGING DATE** field and press **Enter**.
- To add a firm planned order for this item, use **F08**. Additional fields appear at the bottom of the display. Do one of the following:
 - To add a firm planned order, type in the required information and press **Enter**.

Note: To cancel the addition, press any function key shown and do not press **Enter**.

- To start the review (inquiry) again and see any changes you made, use **F03**.
- To change, cancel, or firm an order for this item, use **F05**.

Selection fields appear at the bottom of the display. Do one of the following:

- a. To change an order, type in the information requested and press **Enter**. Additional fields appear at the bottom of the display. Do one of the following:

Note: Changing a planned order firms the order.

- To complete the change, type in any information you want to change and press **Enter**.

Note: To cancel the change, press any function key shown and do not press **Enter**.

- To start the review (inquiry) again, use **F03** and go to display AML452 or AML453.
- To start another change, use **F05**.
- To add a firm planned order for this item, use **F08**.

Contents	Index	Exit
--------------------------	-----------------------	----------------------

- b. To cancel an order, type in the information requested and press Enter. Additional fields appear at the bottom of the display for information only. An informational message also appears. Do one of the following:
 - To complete the cancellation, press **Enter**.
 - Note:** To cancel the action, press any function key shown and do not press **Enter**.
 - To start the review (inquiry) again, use **F03** and go to display AML452 or AML453.
 - To change, cancel, or firm another order, use **F05**.
 - To add a firm planned order for this item, use **F08**.
- c. To firm an order, type in the information requested and press **Enter**. Additional fields appear at the bottom of the display. Do one of the following:
 - To complete the firming of the order, type in any information you want to change and press **Enter**.
 - Note:** To cancel the firming, press any function key shown and do not press **Enter**.
 - To start the review (inquiry) again, use **F03** and go to display AML452 or AML453.
 - To start firming another order, use **F05**.
 - To add a firm planned order for this item, use **F08**.
- d. To add a firm planned order for this item, use **F08**.
- e. To start the review (inquiry) again, use **F03** and go to display AML452 or AML453.

- To review the master schedule for the next item assigned to this planner or family, use **F06**.

Note: If you are reviewing in sequence and this item is the last for this planner or family, display AML450 appears when you use **F06**. Go to display AML450. If you are reviewing a specific item and use **F06**. Go to display AML451.

- To review the master schedules for items assigned to another planner or family, use **F01**. Go to display AML450.
- To review the master schedule for a specific item, use **F02**. Go to display AML451.
- To see more detail about blended demand for each period, use **F07**. Go to display AML454.
- To identify an item you want to skip in later reviews, use **F10**. Go back to the beginning of this step if you are reviewing in sequence. Go to display AML451 if you are reviewing a specific item.

Note: If you are reviewing in sequence and this item is the last for this planner or family, **F10** causes the same action as **F06**. See the previous note about **F06**.

- To change the smoothing date and smoothing code, use **F22**. To start the review (inquiry) again, use **F03**. Go to display AML452 or AML453.

Note: **F22** and the smoothing information appear on display AML452 and AML453 only if Repetitive Production Management (REP) is installed and interfacing with MRP and the item you are reviewing is schedule controlled.

Contents	Index	Exit
--------------------------	-----------------------	----------------------

- To end the session, use **F24**.

Function keys

F01 RESTART causes the Planner/Family Selection display (AML450) to appear. On it you can select a different sequence for review, start the review again at a different point in the sequence, and change the types of items for which you want to see master production schedules.

F02 RESTART-ITEM causes the Item Selection display (AML451) to appear. On it you can review the master production schedule for a specific item.

F03 RESUME INQ (Resume Inquiry) causes display AML452 to appear again with the body updated to show any changes you made. This function key does not appear when the display is in Inquiry mode.

Notes:

1. The following two function keys let you add, change, cancel, or firm orders in this master schedule. Entry fields appear at the bottom of the display so that you can select orders for action, select the kind of action, and type in new or changed information. For the system to accept anything you type in, you must press **Enter** before you press another function key. If you do not, the system ignores what is typed on the display and begins the new action, canceling the previous action. When you change an order, MPSP immediately updates any generated demand from that order for master scheduled component or option items.
2. When you add an order, MPSP does not calculate its generated demand; you must generate master schedules again to see the effects of the additional generated demand.

F05 CHG/CNL (Change/Cancel) causes entry fields to appear at the bottom of the display so that you can select an action and the order you want to affect.

The ORIG (Original) fields show the existing information about the order you selected.

The **NEW** fields are the entry fields. Type over any information shown to change it.

Note: If the order has an exception condition, the **NEW** fields show the recommended changes in date or quantity.

If the order is an open order that you changed previously, your changes appear in the **NEW** fields. To reverse the change, type the information appearing in the ORIG fields into the **NEW** fields.

You must press **Enter** to complete the action. Then the selection fields appear again for you to select another order and action. If you are canceling an order, an informational message appears with the order information. You must press **Enter** again to complete the cancellation. Then the selection fields appear.

F06 NEXT ITEM lets you see the master production schedule of the next item in the sequence you selected (planner or family). If the next item is a production planned item, display AML452 appears again; if it is not, display AML453 appears.

If the current item is the last in the sequence you selected, or the next item begins a new family, **F06** returns you to the Planner/Family Selection display (AML450) so you can select another sequence or change to review by specific item. F06 also returns you to the Selection display (AML450) if the next item is not available.

When you use **F06**, informational messages appear if:

- The next item was not planned during the last planning run
- The next item is at a lower product structure level.

F07 DISPLAY BLEND (Display Blended Demand) causes the Blended Demand display (AML454) to appear so you can see more information about blended demand for each period.

F08 ADD causes entry fields to appear at the bottom of the display so you can add a firm planned order to the master schedule. The word ADDITION appears above the entry fields.

After you press **Enter**, the entry fields appear again so that you can add another order.

F10 SET BYPASS identifies this item as reviewed and maintained. The system does not show you this master schedule again if you type Y for **BYPASS ITEMS ALREADY REVIEWED** on the Planner/Family Selection display (AML450). This function key also works like **F06 NEXT ITEM**, showing you the next item in the sequence you selected or returning you to a Selection display.

F13 SELECT PROCESS causes the Select Item Process display (AMVTIPOD) to appear where you can select a process which will override the Alternate BOM ID, Revision, Routing ID, and Routing version fields if the order is a planned or firm planned order. You cannot change an item process for a scheduled receipt. This function key is active only if EPDM is activated.

F24 END OF JOB ends processing and causes the Master Schedule Planning menu (AMLM20) to appear. The system ignores any information you typed on the display. It also prints the Master Schedule Open Orders Maintenance List (AML455) if you changed any open orders.

Fields

ITEM (ITNBR). The number of the item whose master production schedule appears in the body of the display.

WH (Warehouse). The identifier of the planning warehouse where this item resides.

PRODUCTION PLAN. The source of demand used to plan orders for this item. The MPS planning source code (MSSR) for this item in the Item Master file determines the demand source. If the code is not P (production plan), the master schedule for the item appears on display AML453.

DESC (Description) (ITDSC). A description of the item.

U/M (Unit of Measure) (UNMSR). The unit of measure used for stocking and releasing this item in inventory.

Contents	Index	Exit
--------------------------	-----------------------	----------------------

ORDP (Order Policy Code). A code that identifies the guidelines for ordering this item. For a production planned item, the order policy code must be G. The code appears beside the field name.

Additional information appears below the ORDP field name and code:

NO-OF-PER (Number of Periods of Supply) (NODS): Appears if the ORDP code is G. For a production planned item, this field shows a numeric code for the frequency of planned orders within each period:

- 1 One time per week
- 2 Two times per period
- 3 One time per period
- 4 One time per work day

MIN (Minimum Quantity) (MINQ). The minimum quantity of this item to specify in an order.

MUL (Multiple Quantity) (MULQ). A factor for rounding off order amounts. You should plan orders for this item in multiples of the quantity shown.

MAX (Maximum Quantity) (MAXQ). The maximum quantity of this item to specify in an order.

AVAIL (Available Inventory) (MOHTQ). The quantity of this item currently on hand in inventory. If the available quantity is negative, this field is highlighted.

Note: On display AML453, if the item you are reviewing is a component item, available inventory is the on-hand inventory (MOHTQ) minus current allocations.

SAFTY (Safety Stock) (SAFTY). The quantity of this item reserved as protection against unexpected increases in demand within the item's lead time.

RECDV (Received) (RCPLA or RCPLB). The quantity of this item that has been received into inventory since the beginning of the first production period shown. The system adds this quantity to the sum of all the order quantities for the first period shown to determine the period variance.

SHFC (Shrinkage Factor) (SHFC). A percentage that the system uses to increase order sizes to compensate for scrap or lost material.

LDTIME (Lead Time). The minimum amount of time in work days required:

- To manufacture this item from its components (LTMAN). The number includes the manufacturing lead time adjustment (LTADM).
- To purchase this item from a vendor (LTPUR). The number includes the purchase lead time adjustment (LTADP).

Note: If you specified a standard lot size (LOTSZ) and a variable lead time (LTVAR) for this item, the system uses a quantity-based lead time in this calculation instead of the lead time adjustment (LTADM or LTADP).

The following fields make up the body of the display. Orders appear in chronological order by due date, and time fences appear if you completed the related fields in the Item Master and Item Balance files.

Contents	Index	Exit
-----------------	--------------	-------------

If CONTINUED appears in the lower left of the display, more information exists than can appear at one time. Press **Enter** to see the next set, or use the **PAGING DATE** field to see the orders beginning at the date you specify.

The information shown in the body of the display is for review only; you cannot change it by typing over it. To add, change, cancel, or firm orders, you must use the function keys at the bottom of the display.

SQ (Sequence Number). A system-generated number you can use to identify an order to change, cancel, or firm.

DUE DATE. The date for the information appearing on the line with the date. This field is highlighted if the dates are before today (system date) or after the MPS Cutoff Date.

If the line shows:	the date is:
An order (any type) or requisition	the due date for the order or requisition
Blended demand	the beginning date of the period in which the demand occurs
Item production plan demand	the beginning date of the period in the production plan
A time fence	the date of that time fence
Variance	the beginning date of the production planning period or the date of the last order in the production planning period

ORDER. One of the following appears to identify the type of order:

Sxxxxxxx	An open schedule
Mxxxxxxx	An open manufacturing order
Pxxxxxxx	An open purchase order
Rxxxxxxx	An open requisition
Uxxxxxxx	An unreleased schedule
M-FIRM	Firm planned manufacturing order
P-FIRM	Firm planned purchase order
M-PLAN	Planned manufacturing order
P-PLAN	Planned purchase order

STAT (Order Status). The following three fields are grouped under the STATUS heading to show the current status of the order.

First Status Field: Blanket Orders: This field shows a B if the order is a blanket purchase order. It shows an R if the order is a blanket order release. The field is blank for all other orders.

Note: Blanket orders appear for information only. The system does not use them in any calculations. For calculations, the system uses the blanket order releases as separate orders.

Second Status Field: Order Status (OSTAT or PSTAT): This field shows the order status code for any released manufacturing or purchase order. The field is blank if the order is firm planned or planned.

Contents	Index	Exit
--------------------------	-----------------------	----------------------

The order status codes that can appear for a manufacturing order are:

- 10** Order released, not started
- 40** Order started—material, outside operations, labor, machine, or miscellaneous charges transactions processed
- 50** Production Control and Costing (outside operations, labor, machine, and miscellaneous charges) complete; Inventory Management receipt to stock not reported complete

The order status codes that can appear for a purchase order (including a blanket purchase order release) are:

- 10** Purchase order released
- 20** Purchase receipt to dock
- 30** Purchase receipt to inspection
- 40** Purchase receipt to stock

Third Status Field: Exception Codes (MSOCC): The code in this field identifies a special condition requiring the planner's attention.

Note: No explanations for the codes appear on the display. To see a brief explanation for each code, use the HELP key.

The exception codes are:

- F** Firming required for planned order inside CMLT or order required but planned on this date (CMLT time fence) (planned orders only)
- H** High due date for order or requisition (firm planned order, open order, or requisition)
- L** Low start date for order or requisition (firm planned order, open order, or requisition) or Low due date for order or requisition (firm planned order, open order, or requisition)
- M** Maximum order quantity exceeded (planned orders only)
- P** Pending change (open orders or requisitions)
- X** Exception order created at date of last FPO (planned orders only) to cover all shortages before the date of the last FPO

QUANTITY (ORQTY or POQTY). The quantity of the order (open, firm planned, or planned) or requisition identified in the **ORDER** field of the line.

PROD PLAN (Item Production Plan). The production plan for this item for each period. The date shown for the item production plan quantity is the beginning date of the period.

This field can also show:

- The difference (variance) between the production plan for the period and all orders due during the period. This variance appears on the same day as the last order in the period.

Note: If the variance exceeds one multiple order quantity of the item, this field is highlighted. The ideal variance is zero.

- A shrinkage quantity that is expected for an order.

Contents	Index	Exit
--------------------------	-----------------------	----------------------

RF (Reference). An abbreviation that identifies the quantity in the **PROD PLAN** field. The abbreviations are:

- PL** Item production plan quantity for the period
- SH** Shrinkage quantity expected for the order
- VA** Difference (variance) between the item production plan and all orders due during the period. The variance is highlighted if it exceeds MULT for the item. For details about variance, see Section 2 of this manual.

BLEND (Blended Demand). The greater of forecast or customer/expected customer orders for the period. If customer orders are greater than the forecasted demand for the period, the quantity is highlighted. Blended demand appears on the date of the forecast. If a DEMAND TF appears, blended demand does not include forecasts in the periods before the time fence.

Notes:

1. If customer backlog exists before the beginning of the current period, the display lists daily totals to reflect the distribution of the overdue backlog.
2. If you use the Demand Interface file for loading forecast or customer backlog, or if you use the Customer Order Management (COM) application, information can appear in the Blended Demand field regardless of the planning source for the item. This information may help you to adjust your production plans or forecast.
3. If ISL/MISL is installed, demand from planned intersite orders is added to both the forecast and the customer orders, so it is included in the blended demand.

EXPCT INV (Expected Inventory). A running total of the inventory level for this item. Starting with the quantity available (AVAIL), the system increases inventory by item orders and decreases it by the item's demand. Expected inventory should always be positive. If it becomes negative, the quantity is highlighted.

Note: Any shrinkage quantities shown are for information only. They do not affect the calculation of expected inventory quantities.

DEMAND TF (Demand Time Fence). The end of the frozen period of the master production schedule. Any changes to the production schedule before the Demand Time Fence can affect production schedules seriously and should be resisted. This time fence can mark the limit of the FALT (final assembly lead time) for this item.

If a Demand Time Fence appears, blended demand for this item does not include forecasts in the periods before the fence date. The Demand Time Fence does not appear if the DEMAND TF (time fence) (DMDFN) field is zero or blank in the Item Plan file record for this item.

CMLT TF (Cumulative Material Lead Time, Time Fence). The end of the firm period of the master production schedule. The CMLT Time Fence identifies the total lead time required to produce this item, including time to purchase materials and parts. Production changes between the Demand Time Fence and the CMLT Time Fence should be made only after you consider the impact on production schedules, such as whether components are available to support an increase.

This time fence does not appear if the CMLT (CMTLT) field is zero in the Item Balance file record for this item. If the CMLT is equal to the days specified for the Demand Time Fence, a combined DMD/CMLT Time Fence is printed.

For more information about how time fences affect order planning and about the related exception codes, see Chapter 2, "Managing Master Production Schedule Planning"

CONTINUED/END. If CONTINUED appears at the lower left of the display, pressing **Enter** shows you more of the master production schedule for this item. If END appears at the lower left, pressing **Enter** shows you the first orders again.

PAGING DATE. If you type a date into **PAGING DATE** at the lower left of the display, pressing **Enter** shows you the master schedule beginning with the date you typed in.

ACTION. Type in the code for the kind of action to take. The codes are:

- 1 Change the due date, quantity, start date, or order type for the order
- 2 Cancel an order
- 3 Firm a planned order
- 4 Display item process. (Appears if EPDM is activated, and allows you to select an alternate item process.)

Note: Changing a planned order firms the order.

SEQUENCE NUMBER. Type in the sequence number shown below (SQ) for the order to change, cancel, or firm.

If you type in the sequence number for an order you deleted earlier in the session or that another application (such as Inventory Management) deleted after you started this session, informational messages appear.

After you press **Enter**, the system shows the action you selected and the existing (ORIG) information about the order you selected. Below the **ORIG (Original)** fields are entry fields (**NEW**) so that you can change information. The entry fields also show the existing information so that you can make changes by typing over specific letters or numbers. If you are canceling an order, you cannot type into the entry fields.

Notes:

1. You can't change a schedule.
2. When you cancel an open order, you create a pending (P) change that sets the order quantity to 0. The change remains pending until you cancel the order using open order maintenance. You can maintain open orders through Inventory Management, or through Purchasing, if installed and interfacing. When you cancel a firm planned or planned order, the system deletes the order from the MPSP files immediately.
3. If you change an open order, you must make those changes in IM the next time you select that order for maintenance. After you select an order for IM maintenance, the system deletes all changes made to the order in MPSP. Then MPSP and MRP use the values (start date, due date, and quantity) in IM's files for any further planning or inquiry.

If EPDM is activated and you select **F13**, the following fields appear:

ALT BOM ID. The identifier of the alternate bill of material associated with this item process. This field appears only if EPDM is activated.

Contents	Index	Exit
--------------------------	-----------------------	----------------------

REV (Item revision). The revision identifier associated with this item. This field appears only if EPDM is activated.

ROUTING ID. The identifier of the routing associated with this alternate bill of material. This field appears only if EPDM is activated.

VERSION (Routing version). The version of the routing associated with this alternate bill of material. This field appears only if EPDM is activated.

AML452—Display/Maintain Master Schedule—Production Plan—Schedule Controlled Item

Use this display to show all manufacturing and purchase orders for a schedule controlled item, if Repetitive Production Management (REP) is installed and interfacing with MRP. This display shows the REP schedule and order type, the smoothing date and smoothing code and an additional function key which allows you to change the smoothing date and smoothing code. See the previous description of display AML452 for an explanation of the other fields and function keys.

```

DATE **/**/**          DISPLAY/MAINTAIN MASTER SCHEDULE          AML452 **
ITEM *****          WH ***  PRODUCTION PLAN                   MIN ***** **
DESC *****          U/M **  ORDPC *                          MUL ***** **
AVAIL ***** **     SAFTY ***** **                          ***** **
RECVD ***** **     SHRFC **** LDTIME ***.*  SMDATE **/**/**  SMCODE *
SQ DUE DATE SCH/ORD  STAT  QUANTITY  PROD PLAN  RF  BLEND  EXPCT INV
** **/**/** ***** * ** * ***** ** ***** **_* ** ***** **_* **_*
**/**/** ----- ***** TF -----

```



```

*****
PAGING DATE nnnnn  F01 RESTART-PLANNER  F06 NEXT ITEM  F10 SET BYPASS
                   F02 RESTART-ITEM    F07 DISP BLEND F22 CHG SMOOTHING
                   F05 CHG/CNL         F08 ADD        F24 END OF JOB

```



```

CHANGE SMOOTHING
SMOOTHING DATE nnnnnn  SMOOTHING CODE A
                                     F03 RESUME INQ

```

What to do

See "AML452—Display/Maintain Master Schedule—Production Plan".

Function keys

F22 CHG SMOOTHING lets you change the smoothing date and smoothing code.

Fields

SCH/ORD (Schedule/Order). The REP schedule and order type.

SMDATE (Smoothing Date). A specific date you want smoothing to begin. It is used as an override to the smoothing code. This date is used if it is greater than the system date.

Contents	Index	Exit
--------------------------	-----------------------	----------------------

SMCODE (Smoothing Code). The code specifies if and how smoothing is applied to an item in production. The field can be overridden by the smoothing start date.

Blank No smoothing

- 1** System date plus one workday used to begin smoothing
- 2** First date of demand used to begin smoothing

Contents	Index	Exit
--------------------------	-----------------------	----------------------

AML453—Display/Maintain Master Schedule

Use this display to show all manufacturing and purchase orders for a master scheduled item if the item does not have item production plans as its source of demand. It also shows supporting information about demand, inventory levels, order policies, and manufacturing time limits. This display lets you change the orders you see or add new ones.

This display appears when the item you are reviewing uses one of the following sources of demand:

- Forecasted demand only
- Customer orders only
- Blended demand (the greater of forecasts or customer/expected customer orders for each period)
- Manual (firm planned orders entered by the planner).

Different footers appear at the bottom of the display depending on the function keys and action codes you select. See “AML452—Display/Maintain Master Schedule–Production Plan” for a description of the footers.

Note: If Repetitive Production Management (REP) is installed and interfacing with MRP and the item you are reviewing is schedule controlled, this display shows the REP schedule and order type, the smoothing code and smoothing date, and an additional function key which allows you to change the smoothing date and smoothing code. See “AML452—Display/Maintain Master Schedule–Production Plan–Schedule Controlled Item” on page 4-35 for a description of those fields and function key.

You see this display:

- When the sequence you selected on the Planner Selection display (AML45P) or the Family Selection display (AML45F) shows you an item that is not production planned.
- When you enter the number of an item that is not production planned on the Display/Maintain Master Schedule Item Selection display (AML451).
- When you use **F06 NEXT ITEM** or **F10 SET BYPASS** on display AML452 and the next item is not production planned.

This display, with AML452, lets you review and adjust the order schedule for a master scheduled item before MRP uses those orders to plan orders for components.

Note: Display AML453 is identical to display AML452 in structure and function and almost identical in content. For information about how to use AML453 and descriptions of most fields, see the description of AML452. The following text describes only those fields that differ from the fields on AML452.

```

DATE **/**/**          DISPLAY/MAINTAIN MASTER SCHEDULE          AML453 **
ITEM *****          WH ***   SOURCE *****          MIN ***** **
DESC *****          U/M **   ORDPC *          MUL ***** **
AVAIL ***** **     SAFTY ***** **          *****          MAX ***** **
PLANNING LEVEL **   SHRFC ****  LDTIME *** *
SQ DUE DATE  ORDER  STAT  QUANTITY  DEP DMD  RF  BLEND  EXPCT INV
** **/**/** ***** * ** * ***** ** ***** ** ** ***** ** ***** **
**/**/** ----- ***** TF -----
    
```



```

*****
PAGING DATE nnnnn  F01 RESTART          F05 CHG/CNL      F08 ADD
                   F02 RESTART-ITEM     F06 NEXT ITEM   F10 SET BYPASS
                   F07 DISP BLEND       F24 END OF JOB
    
```

What to do

See “AML452—Display/Maintain Master Schedule–Production Plan”.

Function keys

See “AML452—Display/Maintain Master Schedule–Production Plan”.

Fields

The following fields appear in the heading of display AML453 only. For other fields, see the description of display AML452.

- SOURCE (MSSR).** The demand source the system used to plan orders for this item:
- BLENDED** The greater of forecasts or customer orders for each period
- CUST ONLY** Customer orders only
- FCST ONLY** Forecasts only
- MANUAL** Manually entered firm planned orders

ORDPC (Order Policy Code). A code that identifies the guidelines for ordering this item. The possible codes are:

- A** Discrete order quantity
- B** Order point, order quantity
- C** Order point, order up to level
- D** Fixed quantity
- F** Part period balancing (standard cost)
- G** Time periods of supply
- H** Discrete above a minimum quantity
- I** Part period balancing (current cost)
- Z** User option

Contents	Index	Exit
--------------------------	-----------------------	----------------------

The code appears beside the field name. If the code is D, G, or H, one of the following kinds of information appears below the field name and code:

FOQ (Fixed Order Quantity) (FXORQ): The standard order quantity for this item. Appears if the code is D or H.

NO-OF-PER (Number of Periods of Supply) (NODS): The number many days' supply of this item each order must cover. Appears if the code is G.

PLANNING LEVEL (POLEV). The product structure level at which the system planned this item. The system plans all master scheduled end items at level zero. This field is highlighted if you did not plan this item.

The following fields appear in the body of display AML453 only. For other fields, see "AML452—Display/Maintain Master Schedule—Production Plan".

DUE DATE. The date for the information appearing on the line with the date. This field is highlighted if the dates are before today (system date) or after the MPS cutoff date.

If the line shows:	the date is:
An order (any type) or requisition	the due date for the order or requisition
Blended demand	the beginning date of the period in which the demand occurs
A safety stock requirement	the earliest date the system can plan an order to meet the requirement
A time fence	the date of that time fence
Variance	the beginning date of the production planning period or the date of the last order in the production planning period

Contents	Index	Exit
--------------------------	-----------------------	----------------------

STAT (Order Status).

Note: The STAT (Order Status) heading covers three status fields. The first two fields, **Blanket Orders** and **Open Order Status**, are identical to the fields on display AML452. The third field, **Exception Codes**, can show additional exception codes on display AML453 that do not appear on display AML452 and are not included in that display description. Those codes are included in the list below.

Third Status Field: Exception Codes (MSOCC): The code in this field identifies a special condition requiring the planner's attention.

Note: No explanations for the codes appear on the display. To see a brief explanation for each code, use the **HELP** key. For additional information about the meaning of each code, see "Exception codes for maintaining orders and requisitions".

The exception codes are:

- C** Cancel order (firm planned order, open order, or requisition)
- D** Defer order (firm planned order, open order, or requisition)
- E** Expedite order (firm planned order, open order, or requisition)
- F** Firming required for planned order inside CMLT (planned orders only)
- H** High due date for order (firm planned order, open order, or requisition). The due date is after the end of the MPS cutoff date. If you need this order or requisition, set the due date earlier.
- L** Low start date for order or requisition or Low due date for order or requisition (firm planned order, open order, or requisition). Either the start date for this order or requisition is earlier than the MPS current date, or the due date for this order or requisition is earlier than the MPS current date. This order or requisition is overdue and needs to be completed immediately.
- M** Maximum order quantity exceeded (planned orders only)
- P** Pending change (open orders or requisitions)
- R** Reschedule order (firm planned order, open order, or requisition)
- X** Exception order created at date of last FPO to cover all shortages before the date of the last FPO (planned orders only)

DEP DMD (Dependent Demand) (DMQTY). The demand quantities for this item not based on independent demand. These quantities result from system calculations in the last planning run. The RF field identifies the kind of demand shown.

If the field shows generated demand, the generated demand quantity includes demand calculated in the last planning run. The quantity reflects any changes made to planned orders for the parent item since the last run, but does not reflect planned orders added for the parent. A new planning run is necessary for generated demand to reflect planned orders added for the parent.

Contents	Index	Exit
--------------------------	-----------------------	----------------------

If the field shows an option forecast (FC), it is actually showing demand generated from planned orders for each end item where this option is used. This generated demand is considered and treated like a forecast. Option backlog (OB) from customer orders is accumulated within FC dates generated from the same end item. The option backlog (OB) that satisfies an option forecast (FC) is shown on the same date and immediately below the option forecast it satisfies. When the option backlog (OB) for an interval is greater than the option forecast (FC), the difference is subtracted from the projected inventory.

RF (Reference). An abbreviation that describes the quantity in the DEP DMD field:

- AL** Future allocations of the item
- FC** Generated forecasts for an option resulting from planned orders for a model line
- GE** Demand caused by orders for higher-level items
- OB** Option backlog from customer orders for an option in a model line
- SF** A safety stock requirement
- SH** A shrinkage quantity expected for this order

Note: For more information about option forecasts and how customer orders consume option forecasts, see Chapter 2 "Managing Master Production Schedule Planning".

AML454—Blended Demand

Use this display to show the period sales forecasts and daily customer order/expected customer order totals used to calculate blended demand for master scheduled items. The display provides additional detail for the Display/Maintain Master Schedule displays (AML452 and AML453).

This display appears when you use **F07 DISPLAY BLEND** on either of the Display/Maintain Master Schedule displays (AML452 or AML453). Using F03 returns you to the display from which you started.

On this display, you can see the daily customer backlog and the forecast for each period for the item you are reviewing. You can also see the cumulative backlog per day within each period. This information is available regardless of the demand source you specified for the item.

```

DATE **/**/**          BLENDED DEMAND  SOURCE *****  AML454  **
ITEM *****          DESC *****
PLANNING WAREHOUSE ***  SHIPPED *,**,***
DUE DATE      BLEND DMD  FORECAST    BACKLOG      CUM BACKLOG
**/**/**     *,**,***.***  *,**,***    *,**,***.***  **
**/**/**     -----***** TF -----

*****
PAGING DATE  nnnnnn                                F03 RESUME INQ
                                                    F24 END OF JOB
    
```

What to do

- To review more details about blended demand for this item, press **Enter**. More details exist if CONTINUED appears in the lower left of the display.
- To review details about blended demand for this item starting at a specific date, type the date into the **PAGING DATE** field and press **Enter**.
- To start the review (inquiry) again, use **F03**. Go to display AML452 or AML453.
- To end the session, use **F24**.

Function keys

F03 RESUME INQ (Resume Inquiry) causes the display you came from (AML452 or AML453) to appear so you can review or change more orders.

Contents	Index	Exit
--------------------------	-----------------------	----------------------

F24 END OF JOB ends processing and causes the Master Schedule Planning menu (AMLM20) to appear. The system ignores any information you typed on the display. It also prints the Master Schedule Open Orders Maintenance List (AML455) if you changed any open orders.

Fields

Display AML454 has three sections:

- The heading, which shows reference information about the item
- The body, which shows day-by-day details about the blended demand for the item
- The lower part of the display, which shows function keys, application and system messages, and an entry field for selecting a specific date to start looking at demand details.

The following fields appear in the heading:

SOURCE (Planning Source) (MSSR). The demand source the system used to plan orders for the item you are reviewing:

BLENDED	The greater of forecasts or customer/expected customer orders for each period
CUST ONLY	Customer/expected customer orders only
FCST ONLY	Forecasts only
MANUAL	Manually entered firm planned orders
PROD PLAN	Item production plan

ITEM (ITNBR). The number of the item whose master production schedule you were reviewing on AML452 or AML453.

DESC (Description) (ITDSC). A description of the item.

PLANNING WAREHOUSE. The identifier of the planning warehouse in which the item resides.

SHIPPED (CRPLA or CRPLB). The quantity of this item already shipped from inventory during the first forecast period shown. The system reduces the forecast for that period by the quantity shipped.

The following fields make up the body of the display. All of the fields are for information only. Information appears in chronological order by day, beginning with the date on the first line of the body of the maintenance display you came from (AML452 or AML453).

If CONTINUED appears in the lower left of the display, more details exist than can appear at one time. Press **Enter** to see the next set of details.

Contents	Index	Exit
--------------------------	-----------------------	----------------------

DUE DATE. The date for information appearing on the line with the date. Any date before today (system date) or after the MPS Cutoff Date is highlighted.

If the line shows: the date is:

Blended demand	the beginning date of the period in which the demand occurs
Forecast	the beginning date of the period covered by the forecast
Customer backlog	the due date for the orders
Cumulative backlog	the date of the backlog total shown on the same line
A time fence	the date of that time fence

BLEND DMD (Blended Demand). The greater of forecast or customer/expected customer orders/intersite orders for the period. If customer orders are greater than the forecasted demand, the quantity is highlighted. Blended demand appears on the date of the forecast, or on the beginning date of the period if there is no forecast.

If a Demand Time Fence appears, blended demand includes only customer orders in periods before the time fence.

If the demand source for this item is C (customer orders only), the system blends the customer orders with forecasts of zero even if forecasts exist. However, if a forecast exists and the customer orders for the period exceed the forecast, this field is highlighted.

If customer backlog exists before the beginning of the first period shown, the display lists the daily totals to reflect the distribution of the backlog.

FORECAST. The forecasted demand for each period, shown on the beginning date of the period. The system reduces (consumes) the forecast for the first period shown by subtracting the quantity shipped since the beginning of the period.

If the demand source for this item is F (forecasts only), the system blends demand and shows it. However, the system uses only the forecasts for planning orders for the item.

If a Demand Time Fence appears, forecasts do not affect blended demand in periods before the time fence.

BACKLOG. Total customer orders or expected customer orders per day. If an order is due before today, the **DUE DATE** field on that line is highlighted.

CUM BACKLOG (Cumulative Backlog). A running total of customer orders, expected customer orders, and intersite orders within each period.

DEMAND TF (Demand Time Fence). The end of the frozen period of the master production schedule. This time fence can mark the limit of the FALT (final assembly lead time) for this item.

If a Demand Time Fence appears, blended demand for this item does not include forecasts in the periods before the fence date. The Demand Time Fence does not appear if the DEMAND TF (time fence) (DTFD) field is 0 or blank in the Item Master file record for this item.

Contents	Index	Exit
--------------------------	-----------------------	----------------------

CMLT TF (Cumulative Material Lead Time, Time Fence). The end of the firm period of the master production schedule. The CMLT Time Fence identifies the total lead time required to produce this item, including time to purchase materials and parts.

This time fence does not appear if the CMLT (CMTLT) field is zero in the Item Balance file record for this item. If the CMLT is equal to the days specified for the Demand Time Fence, a combined DMD/CMLT Time Fence is printed.

PAGING DATE. If CONTINUED appears at the lower left of the display, pressing **Enter** shows you more of the blended demand details for this item. If END appears at the lower left, pressing **Enter** shows you the first details again.

If you type a date into this field at the lower left of the display, pressing **Enter** shows you the blended demand beginning at the date you typed in.

Option 3. Test Master Schedule Resources (AML20)

Use this option to calculate (test) for selected planning warehouses the production resources needed to meet the combined master production schedules within the master scheduling horizon.

Note: You must be authorized to the proper level of security in the warehouse you select.

What information you need:

The planning warehouses in which you want to test master schedule resources.

What reports are printed: None.

What forms you need: None.

AMV3HQ—Test Master Schedule Resources

Use this display to select in which planning warehouses to calculate the production resources needed to meet the combined master schedules within the combined master scheduling horizon. You can select a single planning warehouse, or a range of planning warehouses. For each warehouse that falls in the range selected, separate jobs are initiated and separate reports are printed.

Note: You must be authorized to the proper level of security in the warehouses you select.

This display appears when you select option 3 on menu AMLM20.

For the **From** and **To** ranges on this display, the value you type in the **To** field must be greater than or equal to the value you type in the **From** field when both fields are used. The range begins with and includes the value you type in the **From** field; it ends with and includes the value you type in the **To** field.

If you type a value in the **From** field only, the system ends the range with the highest value for that field. If you type a value in the **To** field only, the system begins the range with the lowest value for that field. If you want to select records by a single value instead of a range, use that value in both the **From** and **To** fields.

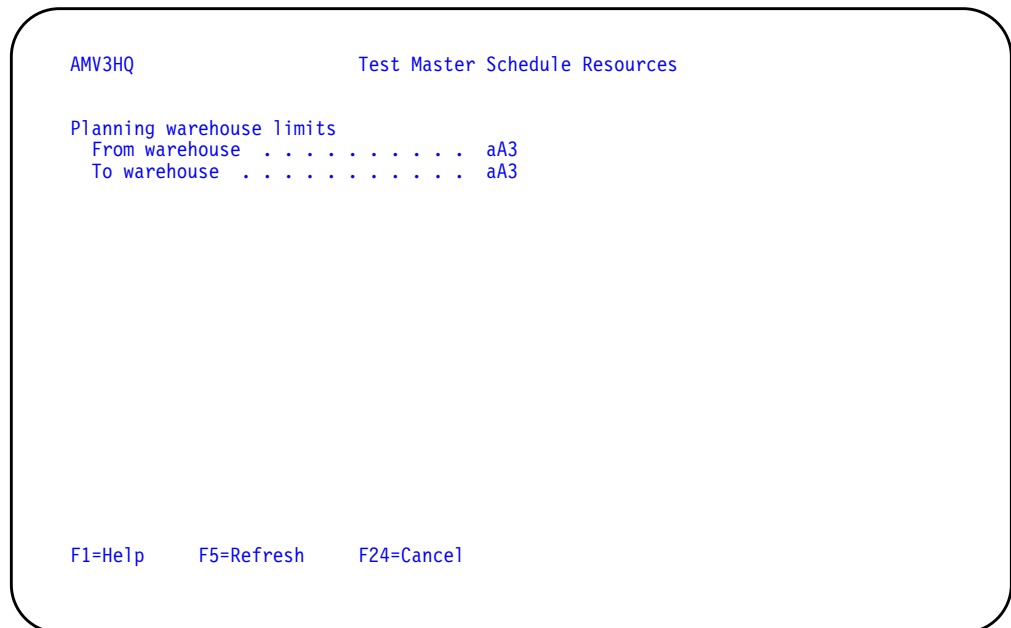

What to do

- To proceed, select a range of planning warehouses and press **Enter**. Display AML180 appears.
- To cancel the session, use **F24**. Menu AMLM20 appears again.

Function keys

F1=Help shows information about this display. Pressing **F1** or pressing the **help** key shows you the same information.

F5=Refresh resets the display as it was before you typed in any values.

Contents	Index	Exit
--------------------------	-----------------------	----------------------

F24=Cancel ends processing and any data you typed is ignored. The Master Schedule Planning menu (AMLM20) appears again.

Fields

[?] appears next to a field name in the following field definitions to identify a field from which you can begin a master file search.

Planning warehouse limits.

From warehouse/To warehouse [?]: The range of warehouses to use for this task.

AML180—Test Master Schedule Resources

Use this display to confirm the planning warehouse selected for resources testing and to initiate the calculations.

The resource tests may be incomplete if master scheduled items at all levels were not planned using Option 1, Generate Master Schedules, on menu AMLM20.

This display appears when you press **Enter** on display AMV3HQ. The display shows the lowest level planned by the master schedule run and the lowest level at which master schedule items exist.

Note: To see the results of this testing, wait until the system finishes the job. Then select option 4, Display Resource Requirements, on menu AMLM20.

```

AML180                                Test Master Schedule Resources

RESOURCE INFORMATION FROM THIS TEST MAY BE
INCOMPLETE IF YOU DID NOT PLAN MASTER SCHEDULED
ITEMS AT ALL LEVELS

PLANNING WAREHOUSE                      ***
LOWEST LEVEL PLANNED                     **
LOWEST LEVEL WHERE
MASTER SCHEDULED ITEMS EXIST           **

                                           F24 END OF JOB
    
```

What to do

- To test master schedule resources, press **Enter**. If you selected a range of planning warehouses on display AMV3HQ, when you press **Enter**, the system submits the job to the job queue and the display appears again with information for the next warehouse in the range. If you selected a single planning warehouse on display AMV3HQ, the system submits the job to the job queue and menu AMLM20 appears.
- To cancel the test, use **F24**. Menu AMLM20 appears again.

Function keys

F24 END OF JOB ends processing and any data you typed is ignored. The Master Schedule Planning menu (AMLM20) appears again.

Option 4. Display Resource Requirements (AMLM20)

Use this option to:

- Review information about the quantities and value of a critical resource needed to meet your combined master production schedules
- Identify the item orders requiring a critical resource during a specific period.

Note: The information on the Resource Requirements displays (AML531, AML532, and AML533) comes from the last time you tested master production schedule resources. A field below the display title shows you that the resource requirements you see come from master scheduled orders.

What information you need:

The number of the critical resource whose uses you want to review and the planning warehouse in which it resides.

What reports are printed: None.

What forms you need: None.

The basic steps to display resource requirements follow each display.

AML531—Resource Requirements Selection

Use this display to identify your planning warehouse selection and to select the critical resource for which you want to see usage requirements and other information by period.

This display appears when you:

- Select option 4 on menu AMLM10 or AMLM20.
- Use **F06** on the Resource Requirements Analysis display (AML532) and no more resources exist in the sequence you started
- Use **F19** on the Resource Requirements Analysis display (AML532).

From this display, you can go to a series of displays that show you for each period how much of the resource is needed, the value of that quantity, and how much of the resource is expected to be available in that period. You can also see details about the families that use the resource in a specific period.

Note: The same series of Resource Requirements displays (AML531, AML532, and AML533) appears when you select option 4 on the Production Planning menu (AMLM10) or option 4 on the Master Schedule Planning menu (AMLM20). However, the information shown depends on the menu option you used.

The field below the display title shows you whether the resource requirements you see come from family operating plans or from master scheduled orders. To see the resource requirements for family operating plans, select option 4 on the Production Planning menu (AMLM10). To see the resource requirements for master scheduled orders, select option 4 on the Master Schedule Planning menu (AMLM20).

You can review a specific resource, all resources, or only the resources with exception conditions. When you review all resources or resources with exception conditions, the resources appear in numeric sequence, beginning with the resource number you type in.

DATE	**/**/**	RESOURCE REQUIREMENTS SELECTION	AML531 MB

PLANNING WAREHOUSE		aA3	
ENTER STARTING RESOURCE NUMBER		aaaA5	
DISPLAY EXCEPTION RESOURCES ONLY <Y/N>		A	
F24 END OF JOB			

Contents	Index	Exit
--------------------------	-----------------------	----------------------

What to do

- To review information about the quantities and the periods when a resource is used, type in the information requested and press **Enter**. Go to display AML532.
- To end the session, use **F24**.

Function keys

F24 END OF JOB ends processing and causes the menu to appear. The system ignores any information you typed on the display.

Fields

[\[?\]](#) appears next to a field name in the following field definitions to identify a field from which you can begin a master file search.

*****. The kind of plans that generated these resource needs: operating plans or master schedule.

PLANNING WAREHOUSE. Type the identifier of the warehouse you want to use.

ENTER STARTING RESOURCE NUMBER [?]. Required. Type in the number identifying the first resource for which you want to see the production requirements by period. You can use **F06 NEXT RESOURCE** on display AML532 to review resources sequentially. Each time you press **F06**, you see resource information for the next higher resource number.

Note: You must have tested your family operating plans (option 3 on the Production Planning menu, AMLM10) before the system can show you any resource requirements. The information you see is the result of the last time you tested family operating plan resources.

DISPLAY EXCEPTION RESOURCES ONLY <Y/N>. Type in **Y** (to see only the resources that use more than the available quantity in one or more periods. Type in **N** to see all resources in sequence. To see a specific resource that does not have an exception condition, you must type N in this field.

AML532—Resource Requirements Analysis

Use this display to show information by period about a critical resource needed to meet the production targets set in your family operating plans.

This display appears when you type in a valid resource number and press **Enter** on the Resource Requirements Selection display (AML531) or when you use **F03** on the Resource Requirements Detail display (AML533).

On this display, you can:

- See the quantity and value of this resource needed for each period, along with the quantity of the resource expected to be available in that period
- See the cumulative difference between resource quantities needed and resource quantities available
- Select a specific period to see details about the families that use the resource in that period.

The system uses the following information to calculate resource usage:

- Resource profiles for the families, based on lead times and other information in the Item Balance, Production Facility, Product Structure, and Routing files
- Current family operating plans
- Resource definitions from the Resource Master file.

If any of that information is incorrect or out of date, the resource calculations are inaccurate.

The number of periods of information you see depends on the length of your family plans. Periods for family operating plans continue to the end of the plans, giving you information for longer-range resource planning at the family level.

Note: The information you see on this display is the result of the last time you tested family operating plan resources.

```

DATE **/**/**          RESOURCE REQUIREMENTS ANALYSIS          AML532 **
RESOURCE NUMBER ***** PRODUCTION PLAN                      U/M ***
DESCRIPTION ***** RESOURCE/DAY *** , *** , ***
PERIOD                RESOURCE          RESOURCE          RESOURCE          CUMULATIVE
DATE                 VALUE             QUANTITY          AVAILABLE          VARIANCE
**/**/**            * , *** , *** , *** . ***  *** , *** , ***  *** , *** , ***  ** , *** , *** , ***

ENTER DATE FOR DETAIL nnnnnn          F06 NEXT RESOURCE  F19 RETURN TO SELECT
*****                                F24 END OF JOB
    
```

What to do

- To review more uses of this resource, press **Enter**. More uses exist if CONTINUED appears in the lower left of the display.
- To review the uses of the next critical resource in the sequence you selected, use **F06**.
- To review the uses of another specific resource, or to begin another sequence of resources, use **F19** and go to display AML531.
- To see details about the production families and production targets using this resource in a specific period, type the date of the period you want to review into the field at the bottom of the display and press **Enter**. Go to display AML533.
- To end the session, use **F24**.

Function keys

F06 NEXT RESOURCE causes this display (AML532) to appear again with information about the next resource in the sequence you are using. If you are at the last resource in the sequence you are using (all resources or only resources with exceptions), **F06** causes the Resource Requirements Selection display (AML531) to appear so you can begin another sequence or start with another resource number.

F19 RETURN TO SELECT causes the Resource Requirements Selection display (AML531) to appear. The system ignores any information you typed on the display.

F24 END OF JOB ends processing and causes the menu to appear. The system ignores any information you typed on the display.

Fields

RESOURCE NUMBER (RMRSC). The number identifying the critical resource whose requirements you are reviewing. You typed this number on the Resource Requirements Selection display (AML531).

OPERATING PLAN. The kind of plans that generated these resource needs.

U/M (Unit of measure) (RMUOM). A code for the unit of measure used in measuring this resource. This code is taken from the Resource Master file.

DESCRIPTION (RMDES). A description that helps to identify the resource. This description is taken from the Resource Master file.

RESOURCE/DAY (RMMAX). The quantity of this resource available for use in one work day. The quantity may reflect average use, a maximum rate of replenishment, or a maximum capacity. This quantity is taken from the Resource Master file.

If CONTINUED appears in the lower left of the display, more periods exist than can appear at one time. Press **Enter** to see the next set of periods.

PERIOD DATE. The beginning date of a production planning period in which this resource is needed. However, the system does not show usage for periods or the part of a period before the system date (today's date): that usage is considered as already expended.

Note: If any quantity or value is too large to appear in the field, the system shows all 9s for that field.

RESOURCE VALUE. The total value (cost) of the resource quantity needed during the period.

RESOURCE QUANTITY. The total quantity of this resource needed during this period. This quantity is the total of all uses of this resource in family member production in the period. If the quantity needed for the period exceeds the quantity available, this field is highlighted.

RESOURCE AVAILABLE. The total quantity of this resource that can be available during this period. This quantity is the resource per day (RMMAX) multiplied by the number of work days in this period.

CUMULATIVE VARIANCE. The cumulative difference, by period, between the total resource quantity available and the total quantity needed. If the cumulative need exceeds the cumulative quantity available, this field becomes negative.

ENTER DATE FOR DETAIL. Type in the beginning date of the period for which you want to see detailed information and press **Enter**. If there are no errors, the Resource Requirement Detail display (AML533) appears with a list of production targets using the resource during that period, the resource quantity for each use, and other supporting information. If there are errors, display AML532 appears again with error messages. The fields in error are highlighted. Correct the errors and press **Enter** to continue processing.

CONTINUED/END. If CONTINUED appears at the lower left of the display and you do not type a date into **ENTER DATE FOR DETAIL**, pressing **Enter** shows you information about resource needs in the next set of periods. If END appears, pressing **Enter** shows you the first periods again.

AML533—Resource Requirements Detail

Use this display to show details about the production families that use a critical resource during a specific period.

This display appears when you type in a valid period date on the Resource Requirements Analysis display (AML532) and press **Enter**.

On this display, you can see the production families that need this resource during this period to meet their family operating plan production targets. You can also see the production targets to change if you want to affect resource use during a specific period.

This display shows the total use of this resource in this period for a family production target. For example, if a resource is a work center and an order requires two operations at this work center during the period, the system adds the two uses and shows one entry for the order with a quantity equal to the two uses combined. If consumption or use of a resource extends across more than one period, the resource need appears in the period when consumption or use ends.

The display includes an entry for a family if the family needs the resource in this period to meet a production goal (production target) in its family operating plan. If the production goals for several periods cause use of this resource during this period, a separate family entry and usage quantity appears for each production goal that generates a need. **ORDER DATE** shows the period date for each production goal.

```

DATE **/**/**          RESOURCE REQUIREMENTS DETAIL          AML533 **
RESOURCE NUMBER ***** PRODUCTION PLAN                    U/M ***
DESC *****          RSC/DAY ***,***,*** PERIOD DATE **/**/**
ITEM          RESOURCE          RESOURCE          ORDER
NUMBER          VALUE          QUANTITY          DATE
*****          * , ** , ** , ** , ** . **          ** , ** , ** . ***** **/**/**
*****
*****
F03 RESUME INQ
F12 ADDL FIELDS
    
```

What to do

- To review more family uses of this resource in this period, press **Enter**. More uses exist if CONTINUED appears in the lower left of the display.
- To start the inquiry again and look at information about other periods, use **F03** and go to display AML532.
- To display or not display the resource description, use **F12**.

Function keys

F03 RESUME INQ (Resume Inquiry) causes the Resource Requirements Analysis display (AML532) to appear. The periods shown are the same as when you last saw the display.

F12 ADDL FIELDS (Additional Fields) causes the item description to display or not display.

Fields

RESOURCE NUMBER (RMRSC). The number identifying the critical resource whose requirements you are reviewing. You typed this number on the Selection display (AML531).

OPERATING PLAN. The kind of plans that generated these resource needs.

U/M (Unit of Measure) (RMUOM). A code for the unit of measure used in measuring this resource. This code is taken from the Resource Master file.

DESC (Description) (RMDES). A description that helps to identify the resource. This description is taken from the Resource Master file.

RSC/DAY (Resource per Day) (RMMAX). The quantity of this resource available for use in one work day. The quantity may reflect average use, a maximum rate of replenishment, or a maximum capacity. This quantity is taken from the Resource Master file.

PERIOD DATE. The beginning date of the period for which this display shows detailed resource usage. You typed this date into **ENTER DATE FOR DETAIL** on display AML532. The entries appear in family number sequence and by target date within the family.

If CONTINUED appears in the lower left of the display, more family operating plan details exist than can appear at one time. Press **Enter** to see the next set of details.

ITEM NUMBER (ITNBR). The Item Master file number of a production family that uses this resource.

Description (ITDSC). A description of the production family.

Note: If any quantity or value is too large to appear in the field, the system shows all 9s for that field.

RESOURCE QUANTITY. The quantity of this resource required to meet the family production target for this period.

RESOURCE VALUE. The cost of the resource quantity needed for this family production target.

ORDER DATE (RTORG). The date of the production target that generated this use.

CONTINUED/END. If CONTINUED appears at the lower left of the display, pressing Enter shows you the next set of targets that need this resource within this period. If END appears, pressing Enter shows you the first targets again.

Option 5. Master Schedule Planning Report (AML20)

Use this option to print the Master Schedule Planning Report (AML471).

What information you need:

- The planning warehouses for which you want master production schedules to be printed
- The lowest-numbered planner or production family for whose items you want master production schedules to be printed
- The highest-numbered planner or production family for whose items you want master production schedules to be printed.

What report is printed:

Master Schedule Planning Report (AML471).

What forms you need: None.

The basic steps to generate a Master Schedule Planning Report follow each display.

AMV3HK—Master Schedule Planning Report

Use this display to select in which planning warehouses to print master production schedules. You can select a single planning warehouse, or a range of planning warehouses. For each warehouse that falls in the range selected, separate jobs are initiated and separate reports are printed.

Note: You must be authorized to the proper level of security in the warehouses you select.

This display appears when you select option 5 on menu AMLM20.

For the **From** and **To** ranges on this display, the value you type in the **To** field must be greater than or equal to the value you type in the **From** field when both fields are used. The range begins with and includes the value you type in the **From** field; it ends with and includes the value you type in the **To** field.

If you type a value in the **From** field only, the system ends the range with the highest value for that field. If you type a value in the **To** field only, the system begins the range with the lowest value for that field. If you want to select records by a single value instead of a range, use that value in both the **From** and **To** fields.

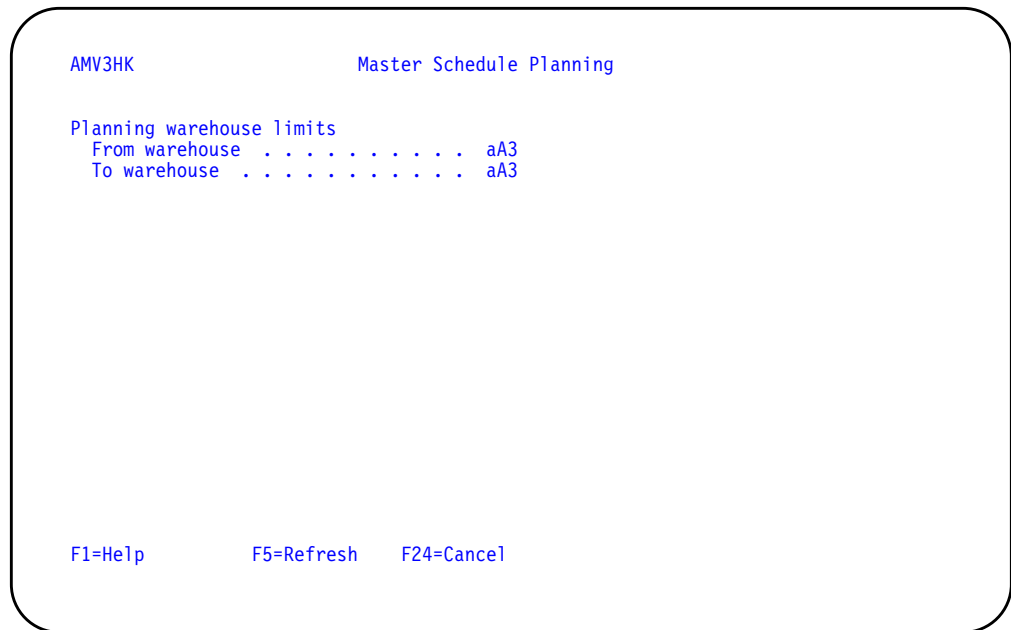

What to do

- To proceed, select a range of planning warehouses and press **Enter**. Display AML180 appears.
- To cancel the session, use **F24**. Menu AMLM20 appears again.

Function keys

F1=Help shows information about this display. Pressing **F1** or pressing the **help** key shows you the same information.

F5=Refresh resets the display as it was before you typed in any values.

Contents	Index	Exit
--------------------------	-----------------------	----------------------

F24=Cancel ends processing and any data you typed is ignored. The Master Schedule Planning menu (AMLM20) appears again.

Fields

[?] appears next to a field name in the following field definitions to identify a field from which you can begin a master file search.

Planning warehouse limits.

From warehouse/To warehouse [?]: The range of warehouses to use for this task.

AML460—Master Schedule Planning Report Options

Use this display to confirm the planning warehouse selected and to define the contents of the Master Schedule Planning Report and start it. You choose the sequence and range of items for which you want to print master production schedules. You can also limit the report to include only items with exception conditions.

This display appears when you press **Enter** on display AMV3HK.

DATE **/**/**	MASTER SCHEDULE PLANNING REPORT OPTIONS	AML460 **
PLANNING WAREHOUSE	***	
SELECT SEQUENCE	n	
1 BY PLANNER		
2 BY FAMILY		
ENTER PLANNER/FAMILY NO.	aaaaaaaaaaaaA15	
UPPER LIMIT (OPTIONAL)	aaaaaaaaaaaaA15	
SELECT ITEMS TO INCLUDE	n	
1 ALL		
2 EXCEPTIONS ONLY		
F24 END OF JOB		

What to do

- To print the Master Schedule Planning Report, type in the requested information and press **Enter**. If you selected a range of planning warehouses on display AMV3HK, the system submits the job to the job queue and the display appears again with information for the next warehouse in the range. If you selected a single planning warehouse on display AMV3HK, the system submits the job to the job queue and menu AMLM20 appears.
- To end the job without printing the report, use **F24**.

Function keys

F24 END OF JOB ends processing and causes the Master Schedule Planning menu (AML20) to appear. The system ignores any information you typed on the display.

Fields

[?] appears next to a field name in the following field definitions to identify a field from which you can begin a master file search.

PLANNING WAREHOUSE. The planning warehouse selected on the previous display AMV3HK. If you selected a range of planning warehouses, the next consecutive identifier appears when you press **Enter**.

Contents	Index	Exit
--------------------------	-----------------------	----------------------

SELECT SEQUENCE. Type in the number of the sequence you want to use for printing the master production schedules.

- 1** BY PLANNER. Prints schedules for all master scheduled items assigned to a planner, beginning with the lowest-numbered planner you specify.
- 2** BY FAMILY. Prints schedules for all master scheduled items assigned to a production family, beginning with the lowest-numbered family you specify.

Note: For each planner, the master schedules appear by product structure level, and by item number within each level. For each family, the master schedules appear according to the priority you assigned to each item when you added it to the family. If you did not assign priorities, items appear in the order they were assigned to the family.

ENTER PLANNER/FAMILY NO. [?]. Optional. Type in the number of the first planner or production family for which you want to print the master production schedules. The report includes items assigned to this and all higher-numbered planners or families, up to the limit you specify.

If you leave this field blank, the report starts with the lowest-numbered planner or family. To print the schedules for all items assigned to planners or families, leave this field and the next field (**UPPER LIMIT**) blank.

UPPER LIMIT (OPTIONAL) [?]. Optional. Type the number of the last planner or production family for which you want to print the master production schedules. The report does not include schedules for items assigned to planners or families with numbers higher than the one you type in.

SELECT ITEMS TO INCLUDE. Type in the number that corresponds to the type of item you want to print schedules for:

- 1** ALL. Schedules are printed for all master scheduled items assigned to the planners or families you specified.
- 2** EXCEPTIONS ONLY. Schedules are printed for items in specified planner or family ranges only if the schedules include exception messages.

Option 6. Available to Promise (AML20)

Use this option to look at the uncommitted quantities of any items that are available to promise.

What information you need:

- The number of the item for which you want to see Available to Promise information.
- Whether to include generated demand from MRP or not.
- The warehouse ID for the item.

What reports are printed: None.

What forms you need: None.

The basic steps to review Available to Promise information follow each display.

AML490—Available to Promise Item Selection

Use this display to select the item, the warehouse, and, optionally, generated demand from Materials Requirement Planning for which you want to see the uncommitted inventory quantities projected for each period within the available to promise horizon.

This display appears when you select option 4 on the Master Production Schedule Planning Main Menu (AMLM00) or option 6 on the Master Schedule Planning menu (AMLM20). It also appears when you use **F12=Cancel** on the Available to Promise display (AMVATP03).

DATE **/**/**	AVAILABLE TO PROMISE ITEM SELECTION	AML490 **
	PLANNING WAREHOUSE	aA3
	ITEM	aaaaaaaaaaaaA15
	INCLUDE GENERATED DEMAND <Y/N>	a
		F24 END OF JOB

What to do

- To see available to promise information, do the following:
 - Either accept the default warehouse ID or replace it with another.
 - Type **Y** to include generated demand from MRP in the calculations or type **N** to exclude the generated demand from MRP.
 - Enter the item number for which you want to see available to promise information and press **Enter**. Go to display AMVATP03 or AMVATP05.
- If there are no errors, pressing **Enter** causes the system to calculate available to promise quantities. Then the appropriate Available to Promise display (AMVATP03 or AMVATP05) appears:
 - AMVATP03 appears if you enter an item number.
 - AMVATP05 appears if you enter a kit number.
- To end the review, use **F24**.

Function keys

F24 END OF JOB ends processing and causes the menu you selected this option from to appear. The system ignores any information you typed on the display.

Fields

[\[?\]](#) appears next to a field name in the following field definitions to identify a field from which you can begin a master file search.

PLANNING WAREHOUSE [?]. Type in the code of the warehouse from which you issue components and to which you receive finished items. The default is the primary planning warehouse. This is the only warehouse used by MPSP. The run sequence shown in this manual is selected from MPSP.

ITEM [?]. Type in the number of the item or kit for which you want to see the quantities in each period that are available for meeting additional demand.

Note: You can enter the number for any item or kit planned in MPSP or in MRP except for the following:

- The number of a production family (master scheduled item code = P)
- The number of a feature (item type code = F).

INCLUDE GENERATED DEMAND <Y/N>. Type **Y** to see generated demand from Material Requirements Planning and Master Production Schedule Planning with customer orders and manufacturing allocations.

AMVATP03—Display Available to Promise

Use this display to review the inventory quantities available to meet additional demand.

This display appears after you enter an item number and additional information on the Available to Promise–Item Selection display (AML490).

```

AMVTAP03                Display Available to Promise
Warehouse . . . . . aA3 *****
Item . . . . . aaaaaaaaaA15 *****
Paging Date . . . . . nnnnN6 On hand quantity . : ***** **n-
                                     MORE: - +
Date      Available      Expected      Demand      Projected      Future
**/**/** to promise    receipts    **/**/**    inventory    unmet demand
**/**/** ****,**n-    ****,**n-    ****,**n-    ****,**n-    ****,**n-
**/**/** ****,**n-    ****,**n-    ****,**n-    ****,**n-    ****,**n-
**/**/** ****,**n-    ****,**n-    ****,**n-    ****,**n-    ****,**n-
**/**/** ****,**n-    ****,**n-    ****,**n-    ****,**n-    ****,**n-
**/**/** ****,**n-    ****,**n-    ****,**n-    ****,**n-    ****,**n-
**/**/** ****,**n-    ****,**n-    ****,**n-    ****,**n-    ****,**n-
**/**/** ----- TF -----
**/**/** ****,**n-    ****,**n-    ****,**n-    ****,**n-    ****,**n-
**/**/** ****,**n-    ****,**n-    ****,**n-    ****,**n-    ****,**n-
**/**/** ****,**n-    ****,**n-    ****,**n-    ****,**n-    ****,**n-
**/**/** ****,**n-    ****,**n-    ****,**n-    ****,**n-    ****,**n-
**/**/** ****,**n-    ****,**n-    ****,**n-    ****,**n-    ****,**n-
**/**/** ****,**n-    ****,**n-    ****,**n-    ****,**n-    ****,**n-
F3=Exit  F7=Backward  F8=Forward  F11=Job Status  F12=Cancel
    
```

What to do

- Enter a paging date to position the data to the date with which you want to work and press **Enter**.
- Use the **Page Up**, **Page Down**, roll keys, **F7** or **F8** to scroll through the data.

Note: The MORE field on the display shows which way the data can be scrolled. If the minus (-) appears, you can scroll backward. If the plus (+) appears, you can scroll forward.
- To see information for a different item or kit, do the following:
 - Enter the item or kit number. this field initially contains the item or kit number entered on display AML490. Press **Enter**.
 - Enter the warehouse ID. This field initially contains the warehouse ID entered on display AML490.
 - Use **F3** to end the job.
 - Use **F11** to see the job status.
 - Use **F12** to return to display AML490.

Function keys

F3=Exit returns you to the previous menu.

F7=Backward scrolls the Available To Promise display backward.

F8=Forward scrolls the Available To Promise display forward.

F11=Job status shows the current job status.

F12=Cancel exits this display and returns you to the Available To Promise–Item Selection display (AML490).

Fields

[\[?\]](#) appears next to a field name in the following field definitions to identify a field from which you can begin a master file search.

Warehouse [?]. This field contains any value entered in **PLANNING WAREHOUSE** on the Available to Promise–Item Selection display (AML490). Type in the desired warehouse code from which the components are issued and the finished items received.

Item [?]. This field contains the value entered in **ITEM** on the Available To Promise–Item Selection display (AML490). Type in the desired item or kit number to see uncommitted inventory.

Paging date. Type in the date you want to review:

- If the entered date is not found, the system uses the next earlier date.
- If the entered date is before the beginning date of the data, the system uses the first available date.
- If the entered date is after the end date of the data, the system uses the last available date.

Warehouse description. A description of the warehouse as defined in the Warehouse Master file.

Item description. A description of the item as defined in the Item Master file.

On hand. This field shows the quantity of this item in inventory.

More. This field is used with **F7=Backward** and **F8=Forward** to show uncommitted inventory.

- The minus sign (-) means you can use **F7** to see previous data on another display.
- The plus sign (+) means you can use **F8** to see more data on another display.

Date. This field shows each day that any demand or receipt activity was found during the Available To Promise calculations. If any overdue demand or receipts are found, the message PAST DUE appears with the overdue demand/receipts, instead of the date.

Available to promise. This field shows the inventory quantity remaining for the date after any future unmet demand is subtracted from projected inventory.

Expected receipts. This field shows the total of all orders (manufacturing, purchase, firm planned, planned, schedules, and requisitions) expected into inventory for the date.

Contents	Index	Exit
--------------------------	-----------------------	----------------------

Demand. This field shows the total number of customer orders, manufacturing allocations, and optionally dependent demand for the item due on the date. This total does not include forecasted demand.

Projected inventory. This field shows the quantity of the item expected in inventory for the date. Expected receipts increase the balance, and demand decreases it.

Future unmet demand. This field shows demand not covered by receipts. Future unmet demand is calculated working backward from the last period, subtracting accumulated receipts from accumulated demand. If the result is zero or negative, the field is blank.

AMVATP05—Display Available to Promise

Use this display to review the inventory quantities for a kit that are available to meet additional demand in each period.

This display appears after you enter a kit number and additional information on the Available to Promise–Item Selection display (AML490).

```

AMVATP05                               Display Available to Promise
Warehouse . . . . . aA3                 *****
Item . . . . . aaaaaaaaaA15           *****
Paging date . . . . . nnnnN6

Date      Kit component      Available      Quantity      More: - +
**/**/** *****a      * ** * ** *n- * ** * ** *n * ** * ** *n-
**/**/** *****a      * ** * ** *n- * ** * ** *n * ** * ** *n-
**/**/** *****a      * ** * ** *n- * ** * ** *n * ** * ** *n-
**/**/** *****a      * ** * ** *n- * ** * ** *n * ** * ** *n-
**/**/** *****a      * ** * ** *n- * ** * ** *n * ** * ** *n-
**/**/** *****a      * ** * ** *n- * ** * ** *n * ** * ** *n-
**/**/** *****a      * ** * ** *n- * ** * ** *n * ** * ** *n-
**/**/** *****a      * ** * ** *n- * ** * ** *n * ** * ** *n-
**/**/** *****a      * ** * ** *n- * ** * ** *n * ** * ** *n-
**/**/** *****a      * ** * ** *n- * ** * ** *n * ** * ** *n-
**/**/** *****a      * ** * ** *n- * ** * ** *n * ** * ** *n-
**/**/** *****a      * ** * ** *n- * ** * ** *n * ** * ** *n-
**/**/** *****a      * ** * ** *n- * ** * ** *n * ** * ** *n-
**/**/** *****a      * ** * ** *n- * ** * ** *n * ** * ** *n-

F3=Exit  F7=Backward  F8=Forward  F11=Job Status  F12=Cancel
    
```

What to do

- Enter a paging date to position the data to the date with which you want to work and press **Enter**.
- Use the **Page Up**, **Page Down**, roll keys, **F7**, or **F8** to scroll through the data.

Note: The **MORE** field on the display shows which way the data can be scrolled. If the minus (-) appears, you can scroll backward. If the plus (+) appears, you can scroll forward.
- To see information for a different item or kit, do the following:
 - Enter the warehouse ID. This field initially contains the warehouse ID entered on display AML490.
 - Enter the item or kit number. this field initially contains the item or kit number entered on display AML490. Press **Enter**.
 - Use **F3** to end the job.
 - Use **F11** to see the job status.
 - Use **F12** to return to display AML490.

Function keys

F3=Exit returns you to the previous menu.

F7=Backward scrolls the Available To Promise display backward.

F8=Forward scrolls the Available To Promise display forward.

F11=Forward displays the current job status.

F12=Cancel exits this display and returns you to the Available To Promise–Item Selection display (AML490).

Fields

[\[?\]](#) appears next to a field name in the following field definitions to identify a field from which you can begin a master file search.

Warehouse [?]. This field contains any value entered in **PLANNING WAREHOUSE** on the Available To Promise–Item Selection display (AML490). Type in the warehouse code from which the components are issued and the finished items received.

Item [?]. This field contains any value entered in **ITEM** on the Available To Promise–Item Selection display (AML490). Type in the desired item/kit number to display uncommitted inventory.

Paging date. Type in the date you want to review:

- If the entered date is not found, the system uses the next earlier date.
- If the entered date is before the beginning date of the data, the system uses the first available date.
- If the entered date is after the end date of the data, the system uses the last available date.

Warehouse description. A unique description of the warehouse.

Item description. A unique description of the item.

More. This field is used with **F7=Backward** and **F8=Forward**.

- The minus sign (-) means you can use **F7** to see previous data on another display.
- The plus sign (+) means you can use **F8** to see more data on another display.

Date. This field shows the latest date that available to promise was calculated for the kit component. The dates are in descending order.

Kit component. This field contains the item number of the kit component in ascending order.

Available to promise. This field shows the inventory quantity remaining in each period after any future unmet demand is subtracted from projected inventory for the date.

Quantity required. This field shows the quantity of component items needed for one kit.

Projected inventory. This field shows the quantity of the item expected in inventory for the date. Expected receipts increase the balance, and demand decreases it.

Option 7. Item Requirements Inquiry (AMLM20)

Use this option to inquire into the requirements plan for items.

Note: To perform tasks in this menu option, you must be authorized to the proper level of security in the warehouse you select.

The item requirements inquiry shows an item's requirements plan: the needs (requirements) for the item and replenishment orders, both released and planned, to fill those needs. Subordinate displays are available to show the source of the requirements (where the requirements are generated from higher-level planned orders) and the planning parameters set up for the item (lot sizing policies, lead time, safety stock).

Note: Planning data for master scheduled items may be incomplete in MRP because MPSP, not MRP, plans these items.

If ISL/MISL is installed, requirements from planned and released intersite orders against this warehouse are included. Intersite orders against another warehouse are included as scheduled receipts.

You can use MRP's inquiry to check on the requirements for an order that is held up because tools or machines are not available. You can inquire about items when you want to release orders that are short of components. You can access these inquiry displays while you are forecasting, scheduling master level items, or releasing orders when you use MRP's inquiry by alternate work session. You can also use these displays to review the results of a planning run. Item requirements inquiry has the same information as the Requirements Planning Report.

The item requirements inquiry can be used in two ways:

- First, you can access a specific item's information directly. To do this, enter a specific planning warehouse and specific item number, and the plan for that item appears. This form of access is normally prompted by some other event (quite often a problem), and fast access is essential.
- Second, you can initiate a systematic review of many items, with the ability to control the search in various ways. This form of access is valuable in anticipating problems and in reviewing the results of a planning run. It is initiated by option 4 on the Demand Management (AMMM10) or by selecting to restart the planner whenever the inquiry is operating. The Item Requirements Inquiry—Select a planner's items display (AMM510) appears, allowing you to enter search criteria or search parameters.

When you enter a planner number, and no items exist assigned to that planner, the next higher planner number in sequence is displayed. The first warehouse assigned to that planner appears in the Planning Warehouse field and the first item number assigned to that warehouse appears in the Item number field. A message appears informing you that the planner number has changed.

If you are not authorized to a warehouse, a message appears informing you of that. When you press Enter the next warehouse in sequence is displayed. The process continues until the search finds a warehouse for which you have proper security authorization or until the end of the file is reached.

Contents	Index	Exit
--------------------------	-----------------------	----------------------

The information that appears on these MRP inquiry displays comes from MRP files. The information coordinates most closely with MPSP information immediately after an MRP planning run in which:

- You transferred master scheduled orders from MPSP
- The MRP Current Date was the same as the MPS Current date.

After that time, activity in MPSP and in MRP makes the information you see on MRP displays increasingly different from MPSP information for the same item.

If you want to review all the items for which a planner is responsible, enter the planner number and press Enter. The application shows the first item assigned to the planner on the Item Requirements Inquiry–Item overview display (AMM511), and you can move from item to item (as you finish with each one) by using F6 or F7 on that display.

You may want to limit your review to only those items that had planning exceptions in the last planning run or only those items that were active in the last planning run. In either case, enter the planner number and the appropriate Items to include value, and press Enter to view the first such item.

You might be responsible for manufactured and purchased items. To review the purchased items first, type in A in the Vendor field (or enter the first vendor number of the vendor with whom the planner is dealing). The application shows the first item with a vendor number present in the vendor field in the Item Balance file.

If you are interrupted before finishing the review and must exit this function, make a note of the item number, vendor number (if the item had one), planning warehouse and the planner number. When you are able to return to the work station (assuming it was used for other purposes while you were gone), enter the item number you were reviewing, vendor number (if applicable), planning warehouse, and the planner number you were last working on. The application repositions you to the place in the file where the interruption occurred, and you can resume your review.

You can review the items you select (in the Items to include field) in sequence by item number within vendor number within warehouse within planner number and you can begin the review at any point you want by entering planning warehouse, planner number, vendor number, and item number as optional starting values. Any field not entered (other than Items to include, which must contain one of the allowed values) defaults to zero (planner) or blank (planning warehouse, vendor, item), and the search begins with those values.

What information you need:

- Planner numbers
- Planning warehouses
- Vendor numbers
- Item numbers
- Items to include.

What reports are printed: None.

What forms you need: None.

The basic steps to an inquire about item requirements follow each display.

AMM510—Item Requirements Inquiry—Select a planner’s items

Use this display to establish search parameters and initiate a sequential review of all items that satisfy those parameters.

This display appears when you use **F1** on any of the other Inquiry displays (AMM511, AMM512, or AMM516) or, in MRP, when you select option 4 on the Demand Management menu (AMMM10). Display AMM510 shows the last planner number, planning warehouse, vendor number, and item number that were shown by planner sequencing, if any. This allows you to press **Enter** to resume planner-sequenced inquiry after an explicit inquiry (see display AMM516), without having to enter the startup information again.

```

AMM510                               Item Requirements Inquiry

Select a planner's items
Planner number . . . . . nnnnn
Planning warehouse . . . . . aA3

Select starting positions
Vendor number . . . . . aaaaA6
Item number . . . . . aaaaaaaaaA15

Enter selection criteria
Items to include . . . . . A  1=All
                               2=With detail
                               3=With any exception
                               4=With an order exception of
                               expedite, reschedule or defer
                               5=Items planned on last generation

Select items where order exception
days are greater than . . . . . nnn

F2=Select by item  F24=Exit
    
```

What to do

- To see the requirements, type the information requested and press **Enter**, or just press **Enter**. If you do not type any information and press **Enter**, the first item for the first planner appears. Go to display AMM511.
- To see a specific item, use **F2**.
- To exit this session, use **F24**.

Function keys

F2=Select by item causes the Item Requirements Inquiry—Select a planner’s items display (AMM516) to appear. This display allows you to access an item by item number alone.

F24=Exit ends processing and any data you may have typed in is ignored. The application menu from which you requested this program appears again.

Contents	Index	Exit
--------------------------	-----------------------	----------------------

Fields

[?] appears next to a field name in the following field definitions to identify a field from which you can begin a master file search.

Select a planner's items.

Planner number. Type in the number of the planner who is primarily responsible for planning the replenishment strategy for the item (or group of items). If no items are found for this planner or the last item for this planner has been shown, a message stating planner has changed appears. When this happens, the application shows the next planner number in this field to permit you to continue.

If you press **Enter** without typing in a planner number, the application assumes zero for the planner number and shows the first master level item, if any, for planner zero.

Planning warehouse [?]. The planning warehouse for the associated data. Type in the name of the warehouse code you would like to use as a starting point for your review. If no items are found for this warehouse, or the last item for this warehouse has been shown, a message stating the warehouse has changed is displayed. When this happens, the application shows the first item for this planner that appears in the lowest (ascending warehouse ID) warehouse.

If you do not have the proper security authorization for a warehouse, a message is displayed informing you of that. When you press **Enter** the next warehouse is displayed. The process continues until a warehouse is found for which you do have the proper authorization or until it reaches the end of the file.

Select starting positions.

Vendor number (from Item Balance file) [?]. Type in the number of the vendor (or supplier) that you want to review. If you handle many items supplied by different vendors and want to review all items supplied by one vendor, type in that vendor number to begin sequenced review with the first item for that vendor.

If you press **Enter** without typing in a vendor number, the application shows the first item for this planner that does not have a vendor number assigned in the Item Balance file. If all items for this planner have vendor numbers assigned, the application shows the first item for the first vendor.

Item number [?]. Type in the number of the first item that you want to review.

If you press **Enter** without typing in an item number, the application shows the first item satisfying the other parameters entered.

Enter selection criteria

Items to include. Type in the number that corresponds to the type of items that you want to review:

- 1 All. Allows you to review all items.
- 2 With detail. Limits the review to those items for which detail information exists.
- 3 With any exception. Limits the review to those items that were identified as having a planning exception in the last MRP planning run.

Contents	Index	Exit
--------------------------	-----------------------	----------------------

- 4** With an order exception of expedite, reschedule or defer. Limits the review to those items which contain an expedite, reschedule or defer exception. When this option is selected, an additional input field becomes available to allow the severity of the exception to be qualified.
- 5** Items planned on last generation. Limits the review to those items that were planned in the last MRP planning run. In a generation run, all items are active, but in a net change run, only items with inventory activity or file maintenance since the previous planning run are planned.

Select items where order exception days are greater than. This field is only applicable for option 4 (With an order exception of expedite, reschedule, or defer) on the items to include selection. If option 4 is not selected, this field is not available for input. This field allows you to select the magnitude of the exception being reviewed. If you enter 10, only orders that have an expedite, reschedule, or defer of greater than 10 days are included in the review.

AMM511–Item Requirements Inquiry–Item overview display

Use this display to review the time-phased material plan for an item: its beginning available balance, the requirements for the item in date sequence, the released and planned replenishment orders sequenced by due date, and the running projected inventory balance.

Note: This and related MRP inquiry displays are especially useful for exploring the peg-to relationships of master scheduled component items.

This display appears when you make valid entries and press **Enter** on display AMM510 or AMM516, or when you use **F3 Resume inquiry**, on display AMM512.

```

AMM511                               Item Requirements Inquiry

Item . : *****                      *****                      Item types . : *****
Planning WHS . : ***                Start date : **/**/**          Current date : **/**/**
Planner number : ****              Vendor . . : *****          Available . : *,**,***,***
Position to date . . . . nnnnnn          *****                      *****
                                          More: - +

-----Requirements-----            -----Orders-----            Projected
Due Date      Quantity  TYP Start DT      Quantity  REFER      Balance      Exception
**/**/**      *****  *** **/**/**      *****  ***          *****  *****  *** ** *****
**/**/**      *****  *** **/**/**      *****  ***          *****  *****  *** ** *****
**/**/**      *****  *** **/**/**      *****  ***          *****  *****  *** ** *****
**/**/**      *****  *** **/**/**      *****  ***          *****  *****  *** ** *****
**/**/**      *****  *** **/**/**      *****  ***          *****  *****  *** ** *****
**/**/**      *****  *** **/**/**      *****  ***          *****  *****  *** ** *****
**/**/**      *****  *** **/**/**      *****  ***          *****  *****  *** ** *****
**/**/**      *****  *** **/**/**      *****  ***          *****  *****  *** ** *****
**/**/**      *****  *** **/**/**      *****  ***          *****  *****  *** ** *****
**/**/**      *****  *** **/**/**      *****  ***          *****  *****  *** ** *****
**/**/**      *****  *** **/**/**      *****  ***          *****  *****  *** ** *****
**/**/**      *****  *** **/**/**      *****  ***          *****  *****  *** ** *****

F1=Select by planner  F2=Select by item  F4=Peg to      F6=Next item
F7=Previous item      F18=Refresh        F21=Item detail F24=Exit
    
```

What to do

- To see the items assigned to a planner, use **F1**. Go to display AMM512.
- To see a specific item, use **F2**. Go to display AMM516. (If you arrived at this display from a specific item inquiry, **F6** does the same action.)
- To see the “Peg to” (or PG) requirements generated for this item and the higher-level item that generated the requirements, use **F4**. Go to display AMM512.
- To see the next item for the current planner and you are now reviewing items sequenced by planner, use **F6**. Go back to the beginning of this step.
- To see the previous item for the current planner and you are now reviewing items sequenced by planner, use **F7**. Go back to the beginning of this step.

Note: If the Item Requirements Inquiry—Select a planner’s items display (AMM510) appears, no more items exist for this planner. A message is generated stating that the planner number has changed. Press **Enter** to continue.

- To rebuild the body portion of the AMM511 display with the most current information, use **F18**.
- To show additional detail about the item, such as order policy, lead time, lot-sizing quantities, and costs, use **F21**.

- To exit this session, use **F24**.

Function keys

F1=Select by planner causes the Item Requirements Inquiry—Select a planner's items display (AMM510) to appear, so you can restart sequenced inquiry at a different position in the file, or to set different search parameters.

F2=Select by item causes Item Requirements Inquiry—Select a planner's items display (AMM516) to appear, so you can go directly to another item by typing in only its item number.

F4=Peg to causes the Item Requirements Inquiry—Peg to display (AMM512) to appear, showing only the generated requirements and time-phased material plan for this item identified as PG or *PG and, for each one, the parent item that generated each requirement if you do not combine requirements in the back log.

F6=Next item causes one of the following to occur:

- If you were using explicit item inquiry, the Item Requirements Inquiry—Select a planner's items display (AMM516) appears again to allow you to enter the next item for inquiry.
- If you were using planner-sequenced item inquiry, the Item Requirements Inquiry display (AMM511) appears again with the next item for the current planner. If no more items exist for this planner, the Item Requirements Inquiry—Select a planner's items display (AMM510) appears again. A message is generated stating that the planner number has changed. Press **Enter** to continue.

F7=Previous item causes one of the following to occur:

- If you were using explicit item inquiry, the Item Requirements Inquiry—Select a planner's items display (AMM516) appears again to allow you to enter the previous item for inquiry.
- If you were using planner-sequenced item inquiry, the Item Requirements Inquiry—Item overview display (AMM511) appears again with the previous item for the current planner. If no more items exist for this planner, the Item Requirements Inquiry—Select a planner's items display (AMM510) appears again. A message is generated stating that the planner number has changed. Press **Enter** to continue.

Note: If display AMM510 appears, it is positioned to the last plannable item for the previous planner or warehouse. Because display AMM450 only processes in a forward direction, if the last plannable item for the planner or warehouse does not fit the selection criteria, pressing **Enter** will move forward the next planner or warehouse (a result of viewing the same item you were reviewing when you pressed **F7=Previous item**).

F18=Refresh rebuilds the body portion of the Item Requirements Inquiry display (AMM511) with the most current information.

F21=Item detail causes the Item Detail displays (AMM171 through AMM176) to appear, showing additional detail about the item, such as lead time factors, order sizing factors, inventory status, item characteristics, and requirements management factors.

Contents	Index	Exit
--------------------------	-----------------------	----------------------

F24=Exit ends the job and any information you typed is ignored. The application menu from which you requested this program appears again.

Fields

Item. The number and description of the item.

Item types. If you are using sequenced inquiry, the words ALL, DETAIL, (3)EXCEPTIONS, (4)EXCEPTIONS or PLANNED appears in this field and indicates the Items to include you selected on display AMM510. If you entered an item number on display AMM516, this field contains EXPLICIT.

Planning WHS (HOUSE). The planning warehouse for the associated data.

Start date (STDT). The planning start date is the earliest date the application allows the planner requirements to exist, and then only if they are "held." This date is also the starting point for the report period intervals, used to summarize generated requirements for printing. The date is set using option 1, Maintain Horizon Values, on the Planning Run s menu (AMMM20).

Current date (CU DT). This date used by the planning run programs as the current date. The date is usually changed just before a planning run, so the date shown is the date used in the last planning run. This date is the earliest date for which a forecast record can exist.

No forecast or planner requirements can exist earlier than this date, except in the case of a "held" requirement, which can be held until the start date.

Propagated forecasts and requirements are prorated as they pass this date, and manual forecasts and requirements are dropped entirely. Held requirements are dropped entirely as they pass the start date. Usually, this date is changed just before a planning run, so the date shown is the date used in the last planning run. This is the date to which the Available field Cumulative Material Lead Time (CMLT) is adjusted.

Planner number. The number of the planner for this item.

Vendor (VNDNR). The vendor number assigned to this item and recorded in the item's Item Balance record. This is usually the primary supplier of the item. See "Accessing information" in the *MRP User's Guide*.

Available. The item's available inventory, adjusted back to the last planning run. The field is calculated as follows: on-hand inventory, minus the difference of the receipts since the last planning run and the shipments since the last planning run, minus the manufacturing allocation quantity adjusted by the future allocation quantity. This field serves as the starting point for the Projected Balance column on the display and represents the starting available balance (on-hand minus allocated to manufacturing) for the last planning run. (MOHTQ minus (RECPL minus CURPL)) minus (MALQT minus FALQT)

The body of the display shows the requirements for the item, the released production and/or purchase orders scheduled to replenish the item, the planned orders created by the application (including any firmed by the planner) to cover the requirements, and the resulting projected inventory balance.

Position to date. If you enter a date in this field and press **Enter**, the application shows you the records beginning at that date.

Contents	Index	Exit
--------------------------	-----------------------	----------------------

Requirements. The first three columns establish the date of the display line and give the quantity and type of the requirements for the item.

Due Date (RQDUD or PODUD). For a requirement, this is the date required; for an order, this is the date due. Therefore, in the simple case where one requirement results in one planned order, the planned order due date equals the requirement date.

Quantity (RQPTY). The quantity of the requirement.

TYP (derived from RQSOR or SAFTY or SHRFC). The type of the requirement. The main categories are planner requirements, and generated requirements.

Planner requirements.

MNL (manual requirement). A requirement manually entered by the planner in maintain master level item schedule. (The Forecasting (FCST) application may generate manual requirements also).

If EC is installed and manual requirements have been created for expected customer orders, they are identified by **ET MANUAL**, where T is one of the following order types:

- A** Make. Customer authorizes you to build the product, but not to ship it.
- B** Buy. Customer authorizes you to buy materials, but not build the product.
- C** Firm. Customer "firm" forecast - no authorization.
- D** Plan. Customer "planning" forecast - no authorization.
- E** Expected orders of multiple types have been combined.

CMN (customer order manual requirement). A requirement automatically entered by the extract independent demand function. Customer order manual requirements may be maintained (through the maintain master level item schedule) if they are in the frozen zone. Customer order manual requirements in the free zone may not be maintained because they will be discarded and regenerated on the next execution of the extract independent demand function.

CMH (customer order manual held requirement). A requirement automatically entered by the extract independent demand function for items with a Plan Customer Order Code (CTPO) = 5, or a customer order manual requirement that has been held in maintain master level item schedule. Being held requirements, they will be retained until the planning Start Date. You can maintain customer order manual held requirements (through the maintain master level item schedule) if they are in the frozen zone. You cannot maintain customer order manual held requirements in the free zone because they are discarded and regenerated on the next execution of the extract independent demand function.

If ISL is installed and interfacing, InterSite orders from other planning warehouses are included as CMH requirements.

HLD (held manual requirement). A manual requirement which has been held in maintain master level item schedule. Normally, requirements are dropped by the application during planning run when they become past due (become earlier than the Current Date, because the Current Date advanced past them). However, requirements can be retained until the planning Start Date by holding them.

FCR (forecast requirement). A forecast requirement propagated by the application in a planning run from forecast generation fields entered in the Item

Contents	Index	Exit
--------------------------	-----------------------	----------------------

Balance and Item Plan records prior to the run. This information is considered a requirement in the planning process. (The master level forecast code (MLFC) for this item is 2).

XXX (intersite requirement). A requirement automatically entered during planning for demand from planned intersite orders on this warehouse. XXX is the transfer warehouse associated with the requesting warehouse for the planned order.

Generated requirements.

PG (Peg to). A requirement generated by a parent item requiring this item as a component.

AL (time-phased allocations). A requirement that is a future time-phased allocation to a released manufacturing order.

SM (structure maintenance). A generated requirement that may be inaccurate due to product structure maintenance in the Product Data Management (PDM) application. A planning run will correct this requirement.

CB (combine). A generated requirement that has been combined according to combine codes in order to show the total requirement needed by this date. Pegging is not possible for this type of generated requirement.

SFY (safety stock requirement). A requirement for the designated safety stock quantity needed on the current date plus the item's lead time.

SHR (Shrinkage Requirement). A requirement for the quantity planned for scrap and other losses expected before the order is received into stock. The application plans orders taking shrinkage into account. As a result, the quantity planned (or released for open orders) is more than the quantity actually required.

Some of the values which may display in the **Type** field may be preceded by an asterisk. If a requirement is preceded by an asterisk, it is not included in the Projected Balance calculation.

Note: If a generated requirement (other than safety stock) is preceded by an asterisk, then the generated requirement is for an MLI type S item. An MLI type S item is planned by the planner, and only manual requirements are planned by the application in a planning run for these items. The generated requirements for these items are therefore not included in the Projected Balance calculation. The planner is responsible for entering manual requirements to satisfy any generated requirements for S type items.

Orders/Schedules. The next three columns on the display give the quantity and type of orders that exist to cover the requirements for the item.

Start DT (Order Start Date) (POSTD). For released orders with activity reported, this is the actual start date. For released orders with no activity reported, and for planned and firm planned orders, this is the planned, or scheduled start date. For planned and firm planned manufacturing orders, this is the required date for the components (unless component lead time adjustment is present). For planned and firm planned orders recommended for release, this date is highlighted.

Contents	Index	Exit
--------------------------	-----------------------	----------------------

Quantity (Order Quantity) (POQTY). For released orders with no activity reported, and for planned and firm planned orders, this is the quantity released, or planned to be released. For released orders with activity reported, this is the quantity remaining open on the order.

REFER (Order Reference) (PORID). The following prefixes identify the type of order:

- M** Manufacturing Order
- P** Purchase Order
- R** Requisition
- S** Schedule
- U** Unreleased schedule
- *B** Blanket purchase order
- X** InterSite order (if ISL is installed and interfacing).

Note: The asterisk signifies that this value is not included in the Project Balance calculation. (Blanket purchase orders are stored for informational purposes only. The releases against a blanket order not the blanket header are actually used in calculations).

For planned and firm planned orders, this field contains the following, where xxxx is PLAN for a planned order or FIRM for a firm planned order.

- M-xxxx** Manufacturing Order
- P-xxxx** Purchase Order
- S-xxxx** Schedule
- R-xxxxxx** Requisition

Projected Balance. The calculated inventory balance for each date on the display. The calculation is: previous balance (the first line uses Available) minus requirement quantity plus order quantity for this date.

Two types of requirements are not subtracted from projected balance. Generated requirements for master level type S items (those identified as either *PG or *CB) are not subtracted, because they are not used by the planning programs. Manual requirements entered by the planner should represent these requirements. Safety stock requirement is not subtracted because of its inherent nature: it is planned to handle unforeseen demand, so it is shown as available inventory.

Exception (RQERC or POERC). The planning exception noted by the application the last time this item was planned. A planning exception can be thought of as an action message in most cases, since the application has detected and is informing you of an out-of-balance condition in the plan. The most typical examples are: release this order (51 RELEASE), expedite this released order (33 EXPDTE), and defer this released order (62 DEFER).

AMM512–Item Requirements Inquiry–Peg To

Use this display to review the generated requirements for the item. It shows the parent items whose planned and firm planned orders generated those requirements.

The information that appears on these MRP inquiry displays comes from MRP files. The information coordinates most closely with MPSP information immediately after an MRP planning run in which:

- You transferred master scheduled orders from MPSP
- The MRP Current Date was the same as the MPS Current Date.

After that time, activity in MPSP and in MRP makes the information you see on MRP displays increasingly different from MPSP information for the same item.

This display appears when you use **F4 Peg to** on display AMM511. From this display you can:

- Restart sequenced inquiry (**F1**)
- Select another item for review (**F2**)
- Review the material plan for the item (**F3**)
- Rebuild the body portion of the display with the most current information (**F18**)
- Review the Item Detailed information displays (AMM171 through AMM175), showing additional detail about the item, such as order policy, lead time, lot-sizing quantities, and costs (**F21**)
- Exit (**F24**).

Use this display to request the time-phased materials plan of any of the listed parent items that generated the requirements for the item you are reviewing. This display serves as the link (or peg) between the item being reviewed and the items generating its requirements. It shows you the parent items responsible for generated requirements, lets you select a parent item, and lets you see its materials plan to determine what requirements it covered with the planned order or how the planned order was lot-sized.

Usually, you are looking at the parent item because you have a problem supplying the original item. Looking at the parent may allow you to change its plan to require fewer of the original item. If not, you may have to peg another level and look at the parent of the parent item, and so forth, until you determine where, if any, some slack or buffer exists in the plan. If no slack or buffer exists, you must decide which products are going to be affected. In any case, you can trace the source of requirements for an item.

```

AMM512                Item Requirements Inquiry - Peg To

Item . : *****      *****      Item types . : *****
Planning WHS . : ***      Start date : **/**/**      Current date : **/**/**
Planner number : *****      Vendor . . : *****      Available . . : *,***,***,***
Position to date . . . . nnnnnn
Enter sequence number . . nn

                                                    More: - +
-----
SEQNO  Generated Requirements  -----Parent Items-----
      Due Date      Quantity  Item Number  Description  Lo Level
**   **/**/**      ***** **      *****
**   **/**/**      ***** **      *****
**   **/**/**      ***** **      *****
**   **/**/**      ***** **      *****
**   **/**/**      ***** **      *****
**   **/**/**      ***** **      *****
**   **/**/**      ***** **      *****
**   **/**/**      ***** **      *****
**   **/**/**      ***** **      *****
**   **/**/**      ***** **      *****
**   **/**/**      ***** **      *****
**   **/**/**      ***** **      *****
**   **/**/**      ***** **      *****
**   **/**/**      ***** **      *****
**   **/**/**      ***** **      *****
**   **/**/**      ***** **      *****
**   **/**/**      ***** **      *****
**   **/**/**      ***** **      *****

F1=Select by planner   F2=Select by item   F3=Resume inquiry   F18=Refresh
F21=Item detail       F24=Exit
    
```

What to do

- To see the requirements for a selected parent item, type in a sequence number and press **Enter**. Go to display AMM511.
- To end the pegging and see the items in planner sequence starting with the current item, use **F1**. Go to display AMM510.
- To end the pegging and see a specific item, use **F2**. Go to display AMM516.
- To resume the inquiry or to review the materials plan for the item identified in the heading of this display, use **F3**. Go to display AMM511.
- To rebuild the body portion of the AMM511 display with the most current information, use **F18**.
- To show additional detail about the item, such as order policy, lead time, lot-sizing quantities, and costs, use **F21**.
- To exit this session, use **F24**.

Function keys

F1=Select by planner causes the Item Requirements Inquiry—Select a planner's items display (AMM510) to appear, allowing you to restart sequenced inquiry at a different position in the file, or to set different search parameters.

F2=Select by item causes the Item Requirements Inquiry—Select a planner's items display (AMM516) to appear, allowing you to go directly to another item for review by typing in its item number.

F3=Resume Inquiry causes the Item Requirements Inquiry—Item overview display (AMM511) to appear with the materials plan for the item identified in the heading of this display.

F18=Refresh rebuilds the body portion of the display with the most current information.

Contents	Index	Exit
--------------------------	-----------------------	----------------------

F21=Item detail causes the Item Detail information displays (AMM171 through AMM176) to be invoked, showing additional detail about the item such as, lead time factors, order sizing factors, inventory status, item characteristics, and requirements management factors.

F24=Exit ends processing and ignores any data that you typed in. The application menu from which you requested this program appears again.

Fields

The header information for this display is the same as that described for the previous display AMM511; it identifies the item being reviewed. Of the remaining fields on this display, only two are available for entry: **Enter sequence number** and **Position to date**. The rest of the fields show the generated requirements for the item and the parent items that generated those requirements as of the last planning run.

Position to date. If you enter a date in this field and press **Enter**, the application shows you the item requirements inquiry records beginning at that date.

Enter sequence number. Type the sequence number of the generated requirement for which you want additional detail information and press **Enter**.

Generated Requirements. The first three columns establish the sequence number of the display line and give the due date and quantity of the requirements for the item:

SEQNO (Sequence Number). An application-assigned field that you can use in selecting a specific requirement for review (see "Enter sequence number" for further detail).

Due Date (RQDUD) The due date of the generated requirement, or the date the item is required for use in manufacturing the parent item.

Quantity (RQQTY) The quantity of the generated requirement.

Parent Items. The next three columns give the item number, description and low level code of the parent item:

Item Number (ITNBR). The number of the parent item generating the requirement.

Description (ITDSC). The description of the parent item generating the requirement.

Lo Level (LOLEV). The low-level code of the parent item generating the requirement. This code is shown to help you determine which parent, if multiple parents appear on the display, you want to review. The lower the number, the closer the parent item is to the end-item.

Contents	Index	Exit
--------------------------	-----------------------	----------------------

AMM516–Item Requirements Inquiry–Select a planner’s items

Use this display to make a direct inquiry by planning warehouse and item number. If you do not know the item number or planning warehouse, use F1 Select by planner to get to Item Requirement Inquiry–Select a planner’s items (AMM510). You can then use display AMM510 to search through the file, starting at the desired point, and use **F6** or **F7** to step from item to item on the Item Requirements Inquiry–Item overview display (AMM511) once the first item appears.

Note: This display is generated by the Material Requirements Planning (MRP) application. This and related MRP inquiry displays are useful for exploring the peg-to relationships of master scheduled component items.

The information that appears on these MRP inquiry displays comes from MRP files. The information coordinates most closely with MPSP information immediately after an MRP planning run in which:

- You transferred master scheduled orders from MPSP
- The MRP Current Date was the same as the MPS Current Date.

After that time, activity in MPSP and in MRP makes the information you see on MRP displays increasingly different from MPSP information for the same item.

This display appears when you use **F2** on any of the other Item Requirements Inquiry displays (AMM510, AMM511 or AMM512). When display AMM516 appears after you use **F2**, it shows the item number and planning warehouse, if any, that were entered the last time this display was used during this inquiry run. This display permits you to compare an item retrieved by planner sequencing to an explicit item, and switch back and forth between them rather than having to remember and type all of the startup information again. (Refer to “AMM510–Item Requirements Inquiry–Select a planner’s items”.)

```

AMM516                               Item Requirements Inquiry
Select a planner's items
Planning warehouse . . . . . aA3
Item number . . . . . aaaaaaaaaA15

F1=Select by planner  F24=Exit
    
```

What to do

- To review an item, type the planning warehouse and the item number. Press **Enter**. Go to display AMM511.

- To see the items assigned to a planner, use **F1**. Go to display AMM510.
- To exit this session, use **F24**. Go to menu.

Function keys

F1=Select by planner causes Item Requirements Inquiry—Select a planner's items display (AMM510) to appear.

F24=Exit causes any data you entered to be ignored. The application menu from which you requested this program appears again.

Fields

[?] appears next to a field name in the following field definitions to identify a field from which you can begin a master file search.

Select a planner's items.

Planning warehouse [?]. Type the planning warehouse for the item you want to review.

Item number [?]. Required. Type the number of the item that you want to review.

AMM171—Item Detail Information—Lead time factors

Use this display to review lead time factors for an item.

The same header information shown on displays AMM172, AMM173, AMM174, AMM175, and AMM176 is also shown here.

```

AMM171                               Item Detail Information
Item . . : *****                               Revision
Warehouse : ***                               Eff From **/**/**
                                           Eff To  **/**/**
                                           Page n of 6

Lead time factors
Lead time code . . . . . : *
Standard manufacturing lead time . . . . . : ***.*
Variable manufacturing lead time . . . . . : ***.*
Manufacturing lead time adjustment . . . . . : **.*
Average manufacturing lead time . . . . . : ***.*
Cumulative manufacturing lead time . . . . . : ***.*
Review lead time . . . . . : ***.*
Vendor lead time . . . . . : ***.*
Safety lead time . . . . . : ***.*
Standard purchase lead time . . . . . : ***.*
Purchase lead time adjustment . . . . . : **.*
Average purchase lead time . . . . . : ***.*
Cumulative material lead time . . . . . : ***.*

F12=Cancel

```

What to do

Review the information on this display. To return to the previous display, use **F24**.

Function keys

F12=Cancel causes the display from which you requested this program to appear again.

Fields

Item. The item number and item description for the item being displayed.

Warehouse. The planning warehouse and warehouse description for the item being displayed.

Site. The identifier of the site that this warehouse is associated with.

Revision. The revision identifier associated with this item. This field appears only if EPDM is activated.

Page n of 6. You may enter the desired page number directly in the field in the upper right portion of the display or you may roll from one page to another using the roll keys.

Contents	Index	Exit
--------------------------	-----------------------	----------------------

Lead time factors.

Lead time code (LTCOD). A code used to indicate whether manufacturing or purchase lead times and adjustments are to be used in calculating lead time for this item.

- M** Manufacture
- P** Purchase

These are the lead times for a standard lot of an item expressed in working days, as follows:

Standard manufacturing lead time (LTMAN). The number of days between order release and its completed receipt to stock. It is the time required to produce an item, assuming all components are available for a single level bill of material.

Variable manufacturing lead time (LTVAM). The portion of STD MFG that is dependent on the quantity produced. It is the run time for all operations that do not have a fixed length of time per standard lot.

Manufacturing lead time adjustment (LTADM). The number of days required for quantity-independent administrative activities such as review and requisition processing time prior to order release.

Average manufacturing lead time (LTMAV). The weighted average number of days between the order release and the order completed receipt to stock.

Cumulative manufacturing lead time (CMFLT). The total number of days to produce an item, assuming all purchased items at every level of the bill of material are in stock.

Review lead time (LTREV). The number of days between creation of the requisition and release of the order to the vendor.

Vendor lead time (LTVEN). The vendor-quoted number of days between the vendor's receipt of your order and delivery to your dock.

Safety lead time (LTSAF). The number of days allocated for unexpected delays.

Standard purchase lead time (LTPUR). The number of days between creation of a requisition and receipt of the item at the dock. It is the sum of Review lead time, Vendor lead time, and Safety lead time.

Purchase lead time adjustment (LTADP). The number of days between receipt of the item at the dock and receipt to stock.

Average purchased lead time (LTPAV). The weighted average number of days between purchase order release and receipt of the item to stock.

Cumulative material lead time (CMTLT). The total number of days to produce an item, assuming no material is on hand. It is the sum of the longest standard purchasing or standard manufacturing lead time at each level rolled up through the bill of material.

AMM172—Item Detail Information—Order/Schedule sizing factors

Use this display to show review order/schedule sizing factors for the item you were reviewing.

Note: Fields that have an asterisk to the left of their description are consolidated fields. These fields have values from demand warehouses accumulated in them. If, for example, planning warehouse A had two demand warehouses associated with it (B and C), the safety stock shown on AMM172 would be the sum of the safety stock from warehouses A, B, and C.

```

AMM172                               Item Detail Information
Item . . : *****                               Revision
Warehouse : ***                               Site ***   Eff From **/**/**
                                                Eff To  **/**/**
                                                Page n of 6

Order/Schedule sizing factors
Order policy code . . . . . : *
Fixed order quantity . . . . . : *,***,***,***
Number days supply to be ordered . . . . . : ***
Minimum lot size . . . . . : *,***,***,***
Maximum lot size . . . . . : *,***,***,***
Multiple lot size . . . . . : *,***,***,***
* Safety stock . . . . . : *,***,***,***
Shrinkage factor . . . . . : ***
Standard lot size . . . . . : *,***,***,***
Standard batch quantity . . . . . : **,***,***,***
Schedule control code . . . . . : (Repetitive not installed)
Smoothing code . . . . . : (Repetitive not installed)
Smoothing date . . . . . : (Repetitive not installed)

F12=Cancel
    
```

What to do

Review the information on this display. To return to the previous display, use **F24**.

Function keys

F12=Cancel causes the display from which you requested this program to appear again.

Fields

See “AMM171—Item Detail Information—Lead time factors” for a description of the header information.

Contents	Index	Exit
--------------------------	-----------------------	----------------------

Order/Schedule sizing factors.

Order policy code (ORDP). One of the following codes that describes the order policy to be used when ordering this item:

- A** Discrete order quantity
- D** Fixed quantity
- F** Part period balancing—standard cost
- G** Time periods of supply (default)
- H** Discrete above a minimum quantity
- I** Part period balancing—current cost
- Z** User option.

Note: Order policy codes B (order point, order quantity) or C (order point, order up to level) never appears on this display, because the MRP application does not deal with order point items.

Fixed order quantity (FXORQ). When the order policy code in the Item Plan file is B, you can leave this field blank if you want the system to dynamically calculate order quantity. Otherwise, when the order policy code is B or D, the quantity of the item that is to be reordered when the quantity available falls below the order point is displayed.

When the order policy code is C, the quantity representing the level that the quantity available should be brought up to whenever the item is reordered is displayed.

When the order policy code is H, the minimum reorder quantity for which an order can be released (defined by your company) is displayed.

Quantity is in terms of the stocking unit of measure.

Number of days supply to be ordered (NODS). The number of days of requirements that should be covered in one order planned by the planning run.

Minimum lot size (MINQ). The minimum order quantity of the item. Any planned order calculated as required by MRP that is for a quantity less than the minimum indicated is increased to this minimum number.

Maximum lot size (MAXQ). The maximum planned order quantity of the item. If the planned order quantity generated by MRP exceeds this maximum, an exception is created to notify the planner that it may be necessary to adjust the order quantity.

Multiple lot size (MULQ). This factor is used in increasing a planned order of the item to a multiple of this quantity. For example, if the planned order was calculated for a quantity of 16 and the multiple was 20, the planned order would be increased to 20. If the original quantity was 35, the planned order would be increased to 40.

***Safety stock (SAFTY).** The quantity of the item carried to guard against unexpected increases in demand or late delivery of replenishment orders.

Shrinkage factor (SHFC). The value used by the planning run to adjust gross requirements not covered by on-hand inventory to account for losses due to expected scrap and other causes.

Contents	Index	Exit
--------------------------	-----------------------	----------------------

Standard lot size (LOTSZ). The standard lot size of the item that is normally ordered. This quantity is used to apportion the setup cost per unit for the item. This field may not be 0 (zero) if the item's Cost Technique code equals R. MRP (if installed and interfacing) can use this field to determine a quantity-based lead time. MPSP can use this field to calculate resource profiles.

Standard batch quantity (SBQTY). This field shows the quantity of the parent item relative to the quantity of each component item. The product structure (recipe or formulation) is expressed in relation to a batch quantity of the parent item as opposed to a quantity of one stocking unit.

Schedule control code (SCHCD) <Y,N>. The item schedule control code. The code tells whether demand for the item is brought into REP when the requirements extract option is selected.

- N** The item is not schedule-controlled. This is the default.
- Y** The item is schedule-controlled.

Note: If Repetitive is not installed, the message Repetitive not installed will appear; otherwise, the schedule control code date will appear.

Smoothing code (SMHCD). The smoothing date is the specific date you want smoothing to begin. It is used as an override to the smoothing code. This date is used if it is greater than the system date.

Note: If Repetitive is not installed, the message Repetitive not installed will appear; otherwise, the schedule control code date will appear.

Smoothing date (SMHDT). The smoothing code specifies if and how smoothing is applied to an item in production. The field can be overridden by the smoothing start date and will only appear for schedule controlled items.

- Blank** No smoothing
- 1** REP schedule release horizon plus one work day
- 2** First date of demand used to begin smoothing.

Note: If Repetitive is not installed, the message Repetitive not installed will appear; otherwise, the smoothing date will appear.

AMM173—Item Detail Information—Inventory status summary

Use this display to review the inventory status of the item you are reviewing.

```

AMM173                               Item Detail Information
Item . . : ***** Revision
Warehouse : *** ***** Site *** Eff From **/**/**
                                           Eff To **/**/**
                                           Page n of 6

Inventory status summary
* On hand . . . . . : * ** ** **
* On order production . . . . . : * ** ** **
* On order purchase . . . . . : * ** ** **
* Manufacturing allocations . . . . . : * ** ** **
* Future allocations . . . . . : * ** ** **
* Pick list requirements . . . . . : * ** ** **
* Activity . . . . . : * ** **
* Shipments since last plan . . . . . : * ** ** **
* Receipts since last plan . . . . . : * ** **
* Issue . . . . . : * ** ** **
* Receipt . . . . . : * ** **
* Adjustments . . . . . : * ** ** **
* Warehouse stock location . . . . . : *****
* Inventory carrying rate . . . . . : .**

F12=Cancel
    
```

What to do

Review the information on this display. To return to the previous display, use **F12**.

Function keys

F12=Cancel causes the display from which you requested this program to appear again.

Fields

See “AMM171—Item Detail Information—Lead time factors” for a description of the header information.

Inventory status summary.

***On hand (MOHTQ).** The quantity of the item presently in stock. This field cannot be changed if the transaction history option was selected during application tailoring. If transaction history is supported, you must use an inventory transaction to change the on hand quantity for this item.

On order production (MPRPQ). The total quantity of the item that is currently on order.

On order purchase (MPUPQ). The total quantity of the item currently on order through purchasing.

Manufacturing allocations (MALQT). The total quantity of this item allocated (reserved) for manufacturing requirements.

Future allocations (FALQT). The total of all manufacturing allocations that have a due date greater than the time-phased allocation fence.

***Pick list requirements (PLREQ).** The total quantity of this item reserved for customer order requirements.

***Activity.** The difference between current shipments and current receipts since the last planning run (RECPL minus CURPL).

***Shipments since last plan (CURPL).** The quantity of the item shipped since the last planning run (in which the item was replanned).

***Receipts since last plan (RECPL).** The quantity of the item received since the last planning run (in which the item was replanned).

Issue (ISSMO). The quantity of the item issued this period or month-to-date.

Receipt (RECMO). The quantity of the item received this period or month-to-date.

Adjustments (ADJMO). The sum of the adjustments (changes) made to the quantity of the item this period or month-to-date.

Warehouse stock location (WHS LC). The code that identifies the location of this item in the warehouse.

Inventory carrying rate. The cost of carrying inventory for one year, expressed as a percentage of the item cost. For items with an order policy of part period balancing (Order Policy codes of F or I), this rate is used to override the standard carrying rate entered during application tailoring of the Inventory Management application.

AMM174—Item Detail Information—Item characteristics

Use this display to review the item characteristics for the item you were reviewing.

```

AMM174                               Item Detail Information
Item . . : *****                               Revision
Warehouse : ***                               Site ***   Eff From **/**/**
                                                Eff To  **/**/**
                                                Page n of 6

Item characteristics
Planner . . . . . : *****
Buyer . . . . . : (Purchasing not installed)
Primary vendor . . . . . : *****
Item type code . . . . . : *
Item class . . . . . : *****
Shelf life . . . . . : *****
Stocking unit of measure . . . . . : **
Purchase unit of measure . . . . . : **
Auto release code . . . . . : *
Floor stock code . . . . . : *
Backflush code . . . . . : *
Value class . . . . . : *
Unit weight . . . . . : * , ** , **
Engineering drawing number . . . . . : *****
Inventory code . . . . . : **
Contract required for auto release code . . . . : *

F12=Cancel
    
```

What to do

Review the information on this display. To return to the previous display, use **F12**.

Function keys

F12=Cancel causes the display from which you requested this program to appear again.

Fields

See “AMM171—Item Detail Information—Lead time factors” for a description of the header information.

Item characteristics.

Planner (PLANIB). The user-assigned code that identifies the person responsible for planning the replenishment strategy for this item.

Buyer (BUYNO). The user-assigned number that identifies the person responsible for buying this item.

Note: If Purchasing is not installed, the message Purchasing not installed will appear.

Primary vendor (VNDNR). The number of the primary vendor supplying this item.

Item type (ITYP).

Code that best describes the type of item:

0	Phantom
1	Assembly or subassembly
2	Fabricated item
3	Raw material
4	Purchased item
9	User option (Special)
F	Feature
K	Kit

Item class (ITCLS). The user-defined code identifying the class or group to which this item belongs. For example, ST might indicate this item is classified with that group of items made of steel.

Note: Uses of item class include the following:

- Sales Analysis can be performed using item class.
- Item Master file maintenance allows percentage change of material (cost) for all items having a specific item class.
- PDM/EPDM cost simulation can be run based on percentage change of material (cost) for all items having a specific item class.
- Several IM reports allow limits to be set using item class and can also be sequenced using item class.

Shelf life (Shelf Life in Days) (QCDAY). The number of days from 1 to 9999 that represents the shelf life for this item. At the end of the number of days shown, this item needs to be inspected again. If the QC CONTROL field is 0, the default is 0.

Stocking unit of measure. The code (user assigned) that defines the measurement basis of on hand quantity and issue quantity for this item. For example, EA (each), KG (kilogram), or CM (centimeter).

Purchase unit of measure (PURUM). The purchase unit of measure for the item if it is different from the stocking unit of measure. For example, wire can be purchased by the coil but issued by the meter.

Contents	Index	Exit
--------------------------	-----------------------	----------------------

Auto release code (ATRL). A code used to define the conditions under which purchase orders or requisitions for this item can be automatically released.

- 0** Do not automatically release requisitions or purchase orders.
- 1** Automatically release requisitions without generating a purchase order.
- 2** Create purchase orders for held single purchase orders not requiring manual release.
- 3** Automatically release single purchase orders requiring manual release.
- 4** Create purchase orders for held blanket purchase orders requiring manual release.
- 5** Automatically release blanket purchase orders not requiring manual release.
- 6** Automatically release held fixed blanket purchase orders.
- 7** Automatically release fixed blanket purchase orders.

Floor stock code (FLSTK). A code that indicates if the floor stock is controlled.

- blank** Not floor stock
- C** Controlled floor stock
- U** Uncontrolled floor stock

Refer to "Floor Stock Considerations" in the *Inventory Management User's Guide* for further information on floor stock components.

Backflush code.

The code that identifies whether component backflushing for controlled floor stock items is done using the component quantity per adjusted for yield or the standard component quantity per.

- 0** Use the value of the backflush code for the warehouse.
- 1** Use adjusted quantity per to backflush (default).
- 2** Use standard quantity per to backflush.

Value class (VALUC). The user-assigned code that identifies the importance of the item. For example, the classes may be A, B, C. FCST (if installed and interfacing) can use this field to classify items that have been coded as master level items (MLI codes M and S).

Unit weight (WEGHT). The item's stocking unit of measure.

Engineering drawing number (ENGNO). The engineering drawing number of the item.

Inventory code (INVFG). One of the following codes is used to classify the item in inventory:

- 1** Inventory item
- 2** Miscellaneous item
- 3** Service item.

Contents	Index	Exit
--------------------------	-----------------------	----------------------

Contract required for auto release code. One of the following codes to indicate how auto release of the item is handled during auto release and the planning run:

- 0** (Default) Use the value for this warehouse in Planning Run Execution Options.
- 1** Yes, a contract is required for auto release to Purchasing.
- 2** No, a contract is not required for auto release to Purchasing. However, the purchase order is not released if an expired contract exists for an item.
- 3** No, a contract is not required for auto release to Purchasing. The purchase order is released with a warning message if an expired contract is encountered.
- 4** No, a contract is not required for auto release to Purchasing. Any contracts are ignored.

AMM175—Item Detail Information—Requirements management factors

Use this display to review the requirements management factors for the item you are reviewing.

```

AMM175                               Item Detail Information
Item . . : *****                               Revision
Warehouse : ***                               Site ***   Eff From **/**/**
                                                Eff To  **/**/**/**
                                                Page n of 6

Requirements management factors
Master level item code . . . . . : *
Master level forecast code . . . . . : *
Forecast quantity per time period . . . . . : *,***,***
Number of forecast periods . . . . . : **
Days per forecast period . . . . . : **
Plan customer order code . . . . . : *
Plan expected customer order code . . . . . : *
Combine requirements code . . . . . : *
Price break conversion factor . . . . . : .****
Period interval code . . . . . : *
Include inventory balance . . . . . : *
Master level print code . . . . . : *
* Requirements planning activity code . . . . . : *
Item reschedule code . . . . . : *
Minimum days to reschedule . . . . . : *****
Reschedule frozen zone . . . . . : *****

F12=Cancel
    
```

What to do

Review the information on this display. To return to the previous display, use **F12**.

Function keys

F12=Cancel causes the display from which you requested this program to appear again.

Fields

The header information is explained on display AMM171

Contents	Index	Exit
--------------------------	-----------------------	----------------------

Requirements management factors.

Master level item code (MLIC). The code used by MRP to indicate if this item is a master level item and, if so, which requirements to use when planning orders.

blank Not a master level item (MLI).

M Multiple source MLI. Both planner-entered (manual, held, and propagated) and generated requirements cause planned orders to be created for this item.

S Single source MLI. Only planner-entered requirements cause planned orders to be created.

Master level forecast code (MLFC). The code used by MRP (if installed and interfacing) to indicate if the master level item is to be forecasted. This code applies only to forecasts propagated in MRP. The available codes are:

0 Do not propagate forecast for this item.

1 Propagate forecast for this item.

2 Propagate requirements equal to forecast for this item.

Note: The following fields (also defined on this display) must contain nonzero values for propagation to occur:

- **Number of Forecast Periods** (FRPD)
- **Days per Forecast Period** (PDDY)
- **Forecast Quantity** (FRQTY).

Forecast quantity per time period (FRQTIB). This field is only used if MRP is installed and interfacing. If FCST is installed and interfacing, this field should be 0 (zero).

Number of forecast periods (FRPD). The number of periods over which this item is to be forecasted in MRP.

Days per forecast period (PDDY). The number of days to be contained in each MRP forecast period.

Plan customer order code (CTPO). This field contains one of the following codes:

- 1** Create requirements equal to all customer orders after the MRP Current Date
- 2** Create requirements for all orders that fall after the release date
- 3** Create requirements for all orders that fall after the review date
- 4** Do not create any requirements
- 5** Create requirements equal to all customer orders, including past due, after the MRP Start Date

Contents	Index	Exit
--------------------------	-----------------------	----------------------

Plan expected customer order code (ETPO) This field contains one of the following codes:

- blank** Default. Use the value in the Warehouse Master record.
- 0** Do not use expected customer orders in planning.
- A** Use only type A (Make) expected customer orders in planning.
- B** Use type A (Make) and type B (Buy) expected customer orders in planning.
- C** Use type A (Make), type B (Buy), and type C (Firm) expected customer orders in planning.
- D** Use type A (Make), type B (Buy), type C (Firm), and type D (Plan) expected customer orders in planning.

Combine requirements code (CMRQ). The code used to indicate if requirements for this item are to be combined during the MRP Requirements Planning run.

Note: You are not able to use the pegged-to-requirements function for any items that have combined requirements.

The four combine interval sizes and the five price break literals are defined on MRP Period Interval display, AMM120. Codes 5 through 9 (price break literals) combine requirements according to the fourth period interval.

The price break literals refer to the price break unit of measure constants printed on the MRP Purchase Planning report. The available codes are:

- 0** Do not combine requirements
- 1** Combine interval 1
- 2** Combine interval 2
- 3** Combine interval 3
- 4** Combine interval 4
- 5** Price break literal 5
- 6** Price break literal 6
- 7** Price break literal 7
- 8** Price break literal 8
- 9** Price break literal 9.

Price break conversion factor (PBCF). The factor used by MRP to convert planning units to purchase units. The factor is described by the price break literal assigned to this item (see Combine requirements code field).

Period interval code (PDIN). The code used by MRP to indicate how requirements detail is presented on the Requirements Planning report. The available codes are:

- 0** Print full detail.
- 1** Summarize according to the first set of print intervals.
- 2** Summarize according to the second set of print intervals.
- 3** Summarize according to the third set of print intervals.

Note: This code corresponds to the print intervals defined on MRP Period Interval display, AMM120.

Contents	Index	Exit
--------------------------	-----------------------	----------------------

Include inventory balance. This field contains one of the following codes:

- 1** Yes. Include inventory balance of this item/warehouse in MRP planning runs.
- 0** No. Do not include inventory balance of this item/warehouse in MRP planning runs. This is the default.

Master level print code (MLPC). The code used by MRP to indicate if this item is printed on MRP MLI reports during master level planning runs. The available codes are:

- blank** Always printed.
- L** Printed only if this item's level was planned.
- S** Service usage. Is not printed on MRP MLI reports.

***Requirements planning activity code (RPFLG).** This field is used to indicate if any activity (such as issues or receipts) has occurred to this item since the last planning run through COM, EC, IM, PDM/EPDM, MRP, PM&C, MPSP, REP, PUR, FCST, or PC&C, as a signal for planning this item again. Possible values are:

- 0** No activity. This item does not need to be planned again in a net change planning.
- 1** Replan. This item has had activity since the last planning run.

Item reschedule code. Code used to indicate whether or not orders for the item (by item/warehouse) can be rescheduled automatically by the system.

- 0** Default to warehouse reschedule code. This is the default.
- 1** Cannot be rescheduled automatically.
- 2** Can be scheduled out.
- 3** Can be scheduled in.
- 4** Can be scheduled both out and in.

Minimum days to reschedule. Specifies the minimum number of days before an order can move for it to be rescheduled automatically by the system.

Reschedule frozen zone. Number of days within which a scheduled receipt or firm planned order will not be rescheduled, by item/warehouse.

AMM176—Item Detail Information—Master scheduling factors

Use this display to review the master scheduling factors for the item you are reviewing.

```

AMM176                               Item Detail Information
Item . . : *****                               Revision
Warehouse : ***                               Site ***  Eff From **/**/**
                                                Eff To  **/**/**
                                                Page n of 6

Master scheduling
Forecasting code . . . . . : *
Master schedule item code . . . . . : *
MPS planning source code . . . . . : *
Demand time fence . . . . . : ***
Resource number . . . . . : *****
Resource number build code . . . . . : *
Production family planner . . . . . : *****

F12=Cancel
    
```

What to do

Review the information on this display. To return to the previous display, use **F12**.

Function keys

F12=Cancel causes the display from which you requested this program to appear again.

Fields

See “AMM171—Item Detail Information—Lead time factors” for a description of the header information.

Contents	Index	Exit
--------------------------	-----------------------	----------------------

Master scheduling.

Forecasting code (FCSC). The code that controls forecasting for this item in this warehouse. The available codes are:

- 0** Do not forecast this item.
- 1** Forecast, but do not pass to MRP/MPSP.
- 2** Pass forecast only to MRP/MPSP.
- 3** Pass both forecast and requirement to MRP/MPSP.

Master schedule item code (MSCOD). The code used by MPSP to indicate if this item is a master scheduled item. If you type in M, MPSP plans orders for the item and ignores any requirements generated or entered for it in MRP. MRP uses the orders created by MPSP during the MRP planning run, based on a run-time option in MRP. The available codes are:

- blank** Not a master scheduled item
- M** Master scheduled item
- P** Production family.

If the master scheduled item (MSI) code is P, the only valid master level item code is blank and the only valid item type code is 0 (Phantom). If the MSI code is M, all item type codes are valid, except for F (Feature) and 0 (Phantom). Refer to display AMVT02 in the *PDM User's Guide* for a definition of the item type codes.

If the MSI code is blank, FCST (if installed and interfacing) uses the forecasting code to determine whether the item is forecast and whether the forecast is passed to MPSP.

Note: To change a master scheduled item code of M or P to blank, you must first delete the family or family member from the MPSP Production Family Relationship file.

MPS planning source code (MSSR). The code used by MPSP to indicate the kind of demand used for generating the master production schedule for this item. The available codes are:

- blank** Not used in MPS planning
- B** Blended demand; the greater of forecasts or customer orders for the period
- C** Customer orders only
- D** Blended demand, planned orders created for each customer order
- E** Forecasts ignored, planned orders created for each customer order
- F** Forecasts only
- M** Manually entered firm planned orders
- P** Item production plan.

If the master scheduled item code is M, this field cannot be blank.

Contents	Index	Exit
--------------------------	-----------------------	----------------------

Demand time fence (DMDFN). The number of days that are used by MPSP as a “frozen” planning zone in the MPSP master production schedules for this item. During this period, blended demand does not include forecasts until the periods after the fence date, and only customer orders are considered as demand. Any changes to the production schedule during the “frozen” period can seriously affect production schedules and should be avoided. This number of days can equal the final assembly lead time (FALT) for this item. The system uses this number to calculate the Demand Time Fence Date in the master production schedule for this item.

Resource number (RSNO). The unique number, assigned by your company, and used by MPSP to identify this item as a critical resource. This field appears if EPDM is activated.

Resource number build code (RSBF). The code used by MPSP to indicate which items or production families can have resource profiles generated. This field appears if EPDM is activated.

Y Build profile
N Do not build profile

Production family planner (PFPL). The identifier of the person responsible for planning the replenishment strategy for this production family. This field appears if EPDM is activated.

Chapter 5. Resource Profile Management

When you select option 3 on the Main Menu (AMLM00), the Resource Profile Management menu (AMLM30) appears.

Option 1. Maintain Resource Master File (AMLM30)	5-3
Option 2. Resource Master File List (AMLM30)	5-14
Option 3. Generate Resource Profiles (AMLM30)	5-17
Option 4. Display and Maintain Resource Profiles	5-31
Option 5. Item Resource Report (AMLM30)	5-40

Before you can test resource needs for your family operating plans (option 3 on menu AMLM10) or for your master production schedules (option 3 on menu AMLM20), you must use options from this menu. You must:

- Define your critical resources (option 1).
- Set up resource profiles for the families or items you want to test. You can generate the profiles automatically (option 3) or construct the profiles yourself (option 4).

You also must have resource profiles before you can print the Item Resource Report (option 5). The Item Resource Report can help you decide how to assign items to production families on the basis of common resources that the items use.

Note: If EPDM is activated, a master file search is available in options 3, 4 and 5 to allow you to search for items in the Item Revision Master file.

```

AMLM30                               Master Production Schedule Planning          *****
                                     Resource Profile Management

Type option or command; press Enter.

  1. Maintain Resource Master File
  2. Resource Master File List
  3. Generate Resource Profiles
  4. Display and Maintain Resource Profiles
  5. Item Resource Report

==> _____

F3=Exit      F4=Prompt  F9=Retrieve  F10=Actions
F11=Job status  F12=Return  F22=Messages

```

Option 1. Maintain Resource Master File. Use this option to define the critical resources to use for resource planning within a selected planning warehouse. The resources can be items, machine time, labor, warehouse space, or any other factors that might limit production.

Note: If the resource is an item or material in the Item Plan file or involves a work center, defining the resource includes making appropriate entries in the Item Plan and Production Facility files. See "AML592—Resource Master File Maintenance (Add)" for more information.

Option 2. Resource Master File List. Use this option to print the Resource Master File List, which contains the information in the Resource Master file for all the critical resources you have defined.

Option 3. Generate Resource Profiles. Use this option to automatically create resource profiles for one production family or master scheduled items, a range of families or items, or all families or items assigned to a planner within a selected planning warehouse. A selection display lets you choose which profiles to generate and set other conditions for the generation.

Notes:

1. To generate profiles for a family or item, you must code the record for that family or item in the Item Plan file with Y in the **RESOURCE PROFILE BUILD CODE** field.
2. Generate Resource Profiles is a batch process. Depending on such factors as the number of critical resources you have defined and the number of items or production families you are generating profiles for, the process can take considerable time. You should schedule the profile generation to minimize your waiting time and to avoid delaying other batch jobs.

Option 4. Display and Maintain Resource Profiles. Use this option to change or delete existing resource profiles (generated or user-created) within a selected planning warehouse. You can also construct resource profiles for items or production families that do not have generated profiles.

Option 5. Item Resource Report. Use this option to print the Item Resource Report (AML321) for all master scheduled end items or only for those not assigned to production families. This option can be performed for an individual planning warehouse or for a range of planning warehouses. The report lists the top five resources used by each item.

Option 1. Maintain Resource Master File (AMLM30)

Use this option to add a new critical resource to the Resource Master file, change the information about a resource in the file, and delete a resource from the file.

What information you need:

- The planning warehouse in which you want to add, change, or delete a resource master.
- A unique number, a description, a unit of measure, and the quantity available per day (optional) for any resource you want to add
- A new description, a new unit of measure, or a new quantity available per day for any resource you want to change
- Whether the resource number must be added to or deleted from a record in the Item Plan file or the Production Facility file.

What report is printed:

Resource Master File Maintenance Edit List (AML599).

Note: This report is optional. This report is printed automatically if you selected it on the questionnaire.

What forms you need: MS-01.

The basic steps to maintain resource master files follow each display.

AML591—Resource Master File Maintenance (Select)

Use this display to begin Resource Master file maintenance by selecting the planning warehouse and resource to maintain, and the kind of action to be performed.

Note: You must be authorized to the proper level of security in the warehouse you select.

This display appears when you select option 1 on the Resource Profile Management menu (AML30). It also appears when you use **F19 RETURN TO SELECT** or press **Enter** on displays AML592, AML593, and AML594.

From this display, you can:

- Add, change, or delete a record in the Resource Master file
- Review the status (number of records active, deleted, and available) of the Resource Master file.

Note: To review your current critical resources or see which numbers are available to use, you can list all of the resources in the Resource Master file and the information you entered about them. Use option 2, Resource Master File List, on menu AML30.

```

DATE **/**/**                RESOURCE MASTER          SELECT  AML591  **
                             FILE MAINTENANCE

                             ENTER--
                             PLANNING WAREHOUSE    aA3
                             RESOURCE NUMBER       aaaA5
                             ACTION CODE          n

SELECT ONE OF THESE ACTIONS
1  ADD
2  CHANGE
3  DELETE

                                     F23 DISPLAY STATUS
                                     F24 END OF JOB
    
```

What to do

- To add a resource, type in the information requested, type **1** in the **ACTION CODE** field, and press **Enter**. Go to display AML592.
- To change a resource, type in the information requested, type **2** in the **ACTION CODE** field, and press **Enter**. Go to display AML593.
- To delete a resource, type in the information requested, type **3** in the **ACTION CODE** field, and press **Enter**. Go to display AML594.
- To review the session status, use **F23** and go to display AML595.

Contents	Index	Exit
--------------------------	-----------------------	----------------------

- To end the session, use **F24**.

Function keys

F23 DISPLAY STATUS ignores any information you typed on this display and causes the Resource Profile File Maintenance (Status) display (AML595) to appear.

F24 END OF JOB ends processing and causes the Resource Profile Management menu (AML30) to appear. The system ignores any information you typed on this display.

Fields

[\[?\]](#) appears next to a field name in the following field definitions to identify a field from which you can begin a master file search.

PLANNING WAREHOUSE [?]. Required. Type in the planning warehouse number containing the resource you want to add, change, or delete.

RESOURCE NUMBER (RMRSC) [?]. Required. Type in the number identifying the critical resource to be added or maintained. If you are adding a resource, the number should be one that you are not already using for another resource.

ACTION CODE. Required. Type in one of the following action codes:

- | | |
|----------|-------------------|
| 1 | Add a resource |
| 2 | Change a resource |
| 3 | Delete a resource |

Contents	Index	Exit
--------------------------	-----------------------	----------------------

AML592—Resource Master File Maintenance (Add)

Use this display to add a critical resource for the selected planning warehouse to the Resource Master file.

This display appears when you select action code 1 on the Resource Master File Maintenance (Select) display (AML591). When you add a resource, the system can use it for:

- Generating resource profiles (option 2, Generate Resource Profiles, on menu AMLM30)
- Testing resource requirements for Family Operating Plans (option 3, Test Family Operating Plan Resources, on menu AMLM10)
- Testing resource requirements for master production schedules (option 3, Test Master Schedule Resources, on menu AMLM20).

After you add a resource and add the resource number to the Item Plan or Production Facility file (see below), you should consider generating resource profiles again for production families and items which use that resource. If you do not generate new profiles, the results of resource testing may be inaccurate.

If the critical resource you are adding is an item or material in the Item Plan file, labor at a work center, or machine time at a work center, you must do the following before the system can include the resource in resource profiles or use it in resource testing:

- For a resource item, add the resource number for the item to the Item Plan file record for that item.
- For a labor or machine resource, add the labor resource number (LABRN) or the machine resource number (MACRN) to the Production Facility file record for the work center which supplies that resource.
- Regenerate resource profiles for items or production families that use the new resource.

```

DATE **/**/**                RESOURCE MASTER      ADD      AML592  **
                              FILE MAINTENANCE

RESOURCE NUMBER  *****  WAREHOUSE  ***
DESCRIPTION      aaaaaaaaaaaaaaaaaaaaaA25
UNIT OF MEASURE  aA3
RESOURCE PER DAY nnnnnnnnn

F18 REFRESH
F19 RETURN TO SELECT
    
```

Contents	Index	Exit
--------------------------	-----------------------	----------------------

What to do

- To add the resource, type in the information requested, and press **Enter**. Go to display AML591.
- To see the display as it was before you typed anything in the fields, use **F18**.
- To cancel what you have done on this display and add another resource, use **F19**. Display AML591 will appear.

Function keys

F18 REFRESH erases all information that you typed on the display. The display appears again as it was before you typed in any information.

F19 RETURN TO SELECT causes the Resource Master File Maintenance (Select) display (AML591) to appear. The system ignores any information you typed on display AML592.

Fields

RESOURCE NUMBER (RES#). The number identifying the resource to be added. This is the resource number that you typed on display AML591. To change the resource number, you must use **F19** to return to display AML591.

WAREHOUSE. The identifier of the planning warehouse containing the resource to be added. This is the warehouse identifier that you typed on display AML591. To change the planning warehouse, you must use **F19** to return to display AML591.

DESCRIPTION (RMDES). Required. Type in a description that helps to identify the resource.

UNIT OF MEASURE (RMUOM). Required. Type in a code for the unit to be used in measuring this resource. Your company defines this code.

RESOURCE PER DAY (RMMAX). Type in the quantity of this resource available for use in one work day. This figure may reflect average use, a maximum rate of replenishment, or a maximum capacity. The system uses this figure to calculate the quantity of this resource that could be available in each period to support family operating plans or master production schedules.

AML593—Resource Master File Maintenance (Change)

Use this option to change the information about a resource for the selected planning warehouse in the Resource Master file.

This display appears when you select action code 2 on the Resource Master File Maintenance (Select) display (AML591).

```

DATE **/**/**              RESOURCE MASTER      CHANGE  AML593  **
                           FILE MAINTENANCE

RESOURCE NUMBER  *****  WAREHOUSE  ***
DESCRIPTION      aaaaaaaaaaaaaaaaaaaaaA25
UNIT OF MEASURE  aA3
RESOURCE PER DAY nnnnnnnn

                                     F18 REFRESH
                                     F19 RETURN TO SELECT
    
```

What to do

- To change the resource, type in the information you need to change. Press **Enter** and go to display AML591.
- To see the display as it was before you changed anything in the fields, use **F18**.
- To cancel what you have done on this display, use **F19** and go to display AML591.
- To change or look at another resource, go to display AML591.

Function keys

F18 REFRESH erases all information that you typed on the display. The display appears again as it was before you typed in any information.

F19 RETURN TO SELECT causes the Resource Master File Maintenance (Select) display (AML591) to appear. The system ignores any information you typed on display AML593.

Fields

RESOURCE NUMBER (RMRSC). The number identifying the resource to be changed. This is the number that you typed on display AML591. To change information about another resource, you must use **F19** to return to display AML591.

Contents	Index	Exit
--------------------------	-----------------------	----------------------

WAREHOUSE. The identifier of the planning warehouse containing the resource to be changed. This is the warehouse identifier that you typed on display AML591. To change the planning warehouse, you must use **F19** to return to display AML591.

DESCRIPTION (RMDES). Type in any change to the description of the resource. This field cannot be blank.

UNIT OF MEASURE (RMUOM). Type in any change to the code for the unit used in measuring this resource. Your company defines this code. This field cannot be blank.

RESOURCE PER DAY (RMMAX). Type in any change to the quantity of this resource available for use in one work day. This figure may reflect average use, a maximum rate of replenishment, or a maximum capacity. The system uses this figure to calculate the quantity of this resource that could be available in each period to support family operating plans or master production schedules.

AML594—Resource Master File Maintenance (Delete)

Use this display to delete all information about a resource for the selected planning warehouse from the Resource Master file.

This display appears when you select action code 3 on the Resource Master File Maintenance (Select) display (AML591).

After you delete a resource and delete the resource number from the Item Plan file or the Production Facility file (see below), you should consider generating resource profiles again for production families and items which used that resource. If you do not generate new profiles, the results of resource testing may be inaccurate.

If the critical resource you are deleting is an item or material in the Item Plan file, labor at a work center, or machine time at a work center, you must do the following to ensure that false resource uses do not appear if you use the resource number again later:

- For a resource item, delete the resource number (RSCNO) for the item from the Item Plan file record for that item.
- For a labor or machine resource, delete the labor resource number (LABRN) or the machine resource number (MACRN) from the Production Facility file record for the work center which supplied that resource.

```

DATE **/**/**                RESOURCE MASTER          DELETE  AML594  **
                             FILE MAINTENANCE

RESOURCE NUMBER  *****  WAREHOUSE   ***
DESCRIPTION      *****
UNIT OF MEASURE  ***
RESOURCE PER DAY *****

                        ***** PRESS ENTER TO DELETE *****

                                           F19 RETURN TO SELECT
    
```

What to do

- To delete the resource, check the resource number to make sure that this is the resource you want to delete. Press **Enter** and go to display AML591.
- To bypass the deletion of this resource, use **F19** and go to display AML591.

Function keys

F19 RETURN TO SELECT causes the Resource Master File Maintenance (Select) display (AML591) to appear. The system does not delete the resource.

Contents	Index	Exit
--------------------------	-----------------------	----------------------

Fields

All of the fields on this display are for information only. You cannot change them from this display. Use the information shown to verify that this is the resource you want to delete.

RESOURCE NUMBER. The number identifying the resource you want to delete. This is the number you typed in on display AML591.

WAREHOUSE. The identifier of the planning warehouse containing the resource to be deleted. This is the warehouse identifier that you typed on display AML591.

DESCRIPTION. The description of the resource.

UNIT OF MEASURE. The code for the unit used in measuring this resource.

RESOURCE PER DAY. The quantity of this resource available for use in one work day.

AML595—Resource Master File Maintenance (Status)

Use this display to show the summary statistics for this file maintenance session and information about the status of the file when you used **F23**.

This display appears when you use **F23 DISPLAY STATUS** on the Resource Master File Maintenance (Select) display (AML591). Much of the information on the Resource Master File Maintenance (Status) display (AML595) is also printed at the end of the Resource Master File Maintenance Edit List (AML599) if you selected that report when you answered the Questionnaire.

```

DATE **/**/**                RESOURCE MASTER          STATUS   AML595  **
                             FILE MAINTENANCE

                             SESSION STATUS
RECORDS ADDED                *****
RECORDS CHANGED              *****
RECORDS DELETED               *****
TOTAL TRANSACTIONS           *****

                                     F24 END OF JOB
    
```

What to do

To return to the Resource Master File Maintenance (Select) display (AML591), press **Enter**.

Function keys

F24 END OF JOB ends processing and causes the Resource Profile Management menu (AML30) to appear.

Fields

All of the fields on this display are for information only. You cannot enter or change any information on this display.

Contents	Index	Exit
--------------------------	-----------------------	----------------------

SESSION STATUS. A summary of maintenance transactions in this session.

RECORDS ADDED: The total number of resources added in this session.

RECORDS CHANGED: The total number of resources changed in this session.

RECORDS DELETED: The total number of resources deleted from the file in this session.

TOTAL TRANSACTIONS: The total number of additions, changes, and deletions performed in this file maintenance session.

[Contents](#)[Index](#)[Exit](#)

Option 2. Resource Master File List (AML30)

Use this option to print the Resource Master File List for a selected range of planning warehouses. This list shows you all the critical resources in the file.

The system submits the job to the job queue after you have selected the range of planning warehouses to use.

What information you need:

The planning warehouse range for which you want to generate the resource master list.

What report is printed:

Resource Master File List (AML581).

What forms you need: None.

AMV3HJ—Resource Master File List

Use this display to select for which planning warehouses the resource master list will be generated. You can select a single planning warehouse, or a range of planning warehouses. For each warehouse that falls in the range selected, separate jobs are initiated and separate reports are printed.

Note: You must be authorized to the proper level of security in the warehouses you select.

This display appears when you select option 2 on menu AMLM30.

For the **From** and **To** ranges on this display, the value you type in the **To** field must be greater than or equal to the value you type in the **From** field when both fields are used. The range begins with and includes the value you type in the **From** field; it ends with and includes the value you type in the **To** field.

If you type a value in the **From** field only, the system ends the range with the highest value for that field. If you type a value in the **To** field only, the system begins the range with the lowest value for that field. If you want to select records by a single value instead of a range, use that value in both the **From** and **To** fields.

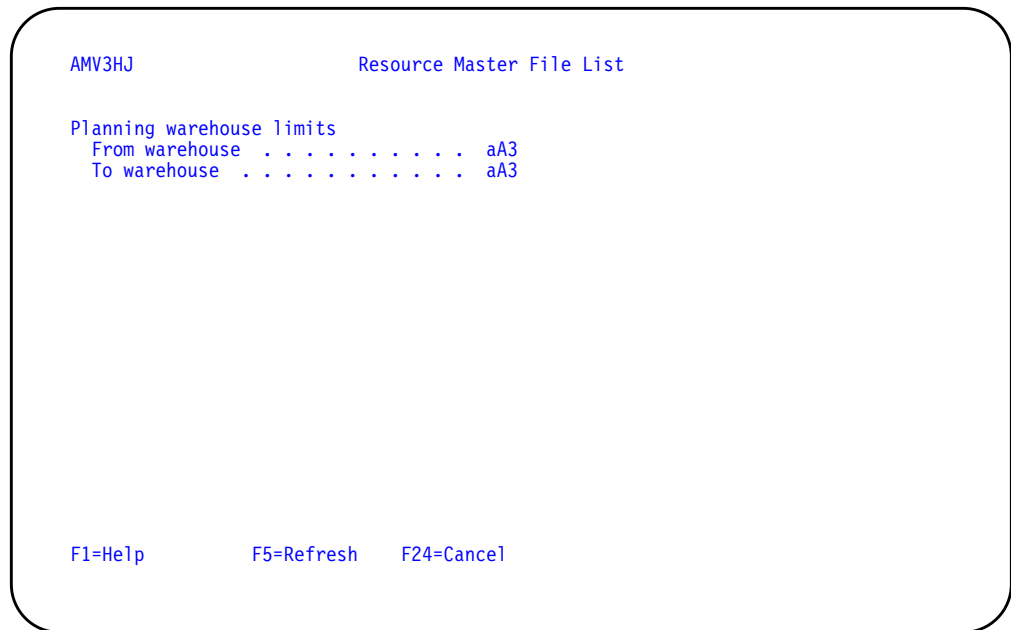

What to do

- To proceed, select a range of planning warehouses and press **Enter**. The system submits the job to the job queue. Menu AMLM30 appears again.
- To cancel the session, use **F24**. Menu AMLM30 appears again.

Function keys

F1=Help shows information about this display. Pressing **F1** or pressing the **help** key shows you the same information.

F5=Refresh restores the display to its status before you made any changes.

Contents	Index	Exit
--------------------------	-----------------------	----------------------

F24=Cancel ends processing and any data you typed is ignored. The Master Schedule Planning menu (AMLM20) appears again.

Fields

[?] appears next to a field name in the following field definitions to identify a field from which you can begin a master file search.

Planning warehouse limits.

From warehouse/To warehouse [?]: The range of warehouses to use for this task.

Option 3. Generate Resource Profiles (AMLM30)

Use this option to calculate new resource profiles for your master scheduled items or production families for a selected range of planning warehouses.

What information you need:

- The range of planning warehouses for which you want to generate resource profiles
- The minimum percent of lead time deviation you want to use for items on the Resource Profile Exception Report (AML559) to be printed
- The effective date that determines whether items are included in their families' resource profiles.

Note: For the system to generate a resource profile for an item or production family, the item or family must have Y in the **RESOURCE PROFILE BUILD CODE** field of its Item Plan file record.

What report is printed:

Resource Profile Exception Report (AML559).

What forms you need: None.

The basic steps to generate resource profiles follow each display.

AMV3HI—Generate Resource Profiles

Use this display to select the kinds of resource profiles you want to generate within the range of planning warehouses you choose. You can select a single planning warehouse, or a range of planning warehouses. For each warehouse that falls in the range selected, separate jobs are initiated and separate reports are printed.

This display appears when you select option 3 on menu AMLM30.

Note: You must be authorized to the proper level of security in the warehouses you select.

For the **From** and **To** ranges on this display, the value you type in the **To** field must be greater than or equal to the value you type in the **From** field when both fields are used. The range begins with and includes the value you type in the **From** field; it ends with and includes the value you type in the **To** field.

If you type a value in the **From** field only, the system ends the range with the highest value for that field. If you type a value in the **To** field only, the system begins the range with the lowest value for that field. If you want to select records by a single value instead of a range, use that value in both the **From** and **To** fields.

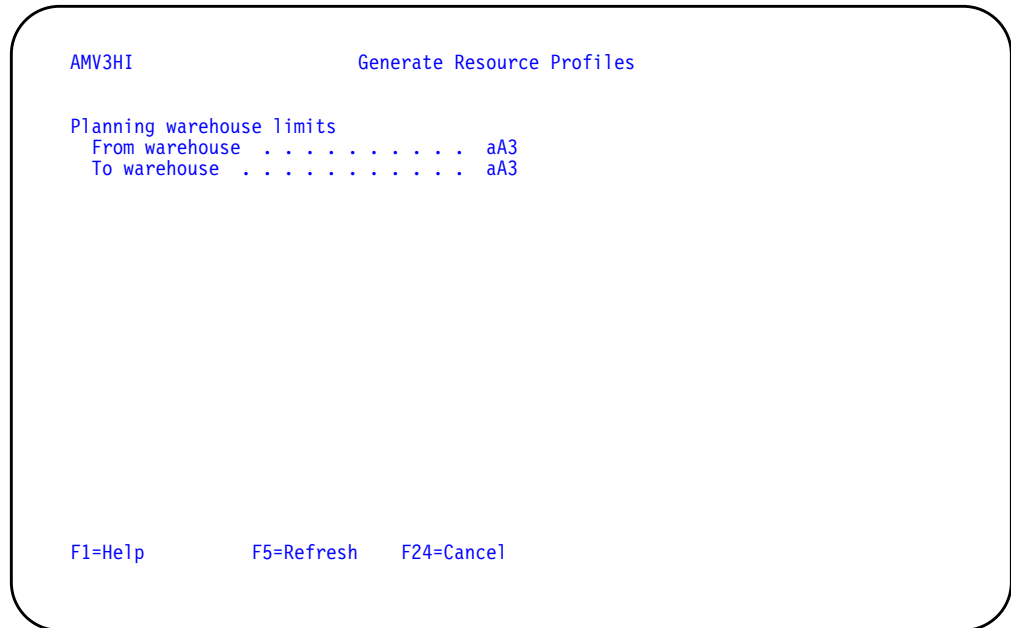

What to do

- To proceed, select a range of planning warehouses and press **Enter**. Display AML501 appears so you can select other options you want to use.
- To cancel the session, use **F24**. Menu AMLM30 appears again.

Function keys

F1=Help shows information about this display. Pressing **F1** or pressing the **help** key shows you the same information.

F5=Refresh restores the display to its status before you made any changes.

Contents	Index	Exit
--------------------------	-----------------------	----------------------

F24=Cancel ends processing and any data you typed is ignored. The Master Schedule Planning menu (AMLM20) appears again.

Fields

[?] appears next to a field name in the following field definitions to identify a field from which you can begin a master file search.

Planning warehouse limits.

From warehouse/To warehouse [?]: The range of warehouses to use for this task.

AML501—Generate Resource Profiles Selection

Use this display to select the kinds of resource profiles you want to generate within a planning warehouse. The display lets you change the minimum you set for identifying excessive lead time deviations. It also lets you change the date that determines the items the system includes when it calculates production family resource profiles.

This display appears when you press **Enter** on display AMV3HI.

Note: You must be authorized to the proper level of security in the warehouses you select.

Before you generate resource profiles, you must:

- Define the critical resources that the system uses to create item or production family resource profiles (option 1, Maintain Resource Master File, on the Resource Profile Management menu, AMLM30).
- Enter the assigned resource number into the Item Plan file record for any item (for example, a purchased item) identified as a critical resource.
- Enter the assigned machine or labor resource numbers into the Production Facility file record for any work center that includes those resources.
- Identify the items or production families that are eligible for resource profiles by entering **Y** in the **RESOURCE PROFILE BUILD CODE** field of the Item Plan file record for each eligible item or family.
- Aggregate item information to the family level (option 1 on the Production Planning menu, AMLM10) if you intend to generate profiles for production families. During aggregation the system calculates the percentage of contribution each item makes to the family's total demand. That percentage is necessary for calculating resource needs for the family.

You can generate new profiles when you:

- Complete an aggregation in which the demand for one or more items changed significantly. The change in demand changes the percent of contribution of an item to its family, making any previous resource profile for that family obsolete.
- Define new critical resources whose numbers you enter into the Item Plan file or the Production Facility file.
- Change the composition of production families.
- Add master scheduled items or production families.

After you have generated profiles, you may want to review item or family profiles and change them, or add special resources that were not calculated in the generation. To do that, use option 4, Display and Maintain Resource Profiles, on the Resource Profile Management menu (AMLM30).

The sequence you select for generating profiles determines whether other displays appear asking you to set further limits.

- If you generate profiles by production family, the Generate Resource Profiles Family Selection display (AML502) appears.
- If you generate profiles by item, the Generate Resource Profiles Item Selection display (AML503) appears.

- If you generate profiles for both items and families, no further displays appear. You begin the generation from this display (AML501).

When resource profile generation is complete, the Resource Profile Exception Report (AML559) for each planning warehouse selected is printed automatically.

```

DATE **/**/**          GENERATE RESOURCE PROFILES          AML501  **
                        SELECTION

PLANNING WAREHOUSE          ***

GENERATE ALL PROFILES <Y/N>          A
KEEP USER CREATED/MAINTAINED PROFILES <Y/N>          A

ENTER LEAD TIME DEVIATION PERCENT          nn

GENERATE RESOURCE PROFILES FOR          n
1 MASTER SCHEDULED ITEMS
2 PRODUCTION FAMILIES
3 BOTH

PROFILES EFFECTIVE AS OF          nnnnnn

                                     F24 END OF JOB
    
```

What to do

- To generate resource profiles for all master scheduled items, for all production families, or for all items and families, type in **Y** for **GENERATE ALL PROFILES <Y/N>** and **1**, **2**, or **3** for **GENERATE RESOURCE PROFILES FOR**. Type in the other information requested and press **Enter**. Go to display AML508.
- To generate one resource profile or a range of profiles for master scheduled items only, type in **N** for **GENERATE ALL PROFILES <Y/N>** and **1** for **GENERATE RESOURCE PROFILES FOR**. Type in the other information requested and press Enter. Go to display AML503.
- To generate one resource profile or a range of profiles for production families only, type in **N** for **GENERATE ALL PROFILES <Y/N>** and **2** for **GENERATE RESOURCE PROFILES FOR**. Type in the other information requested and press Enter. Go to display AML502.
- To end the session, use **F24**.

Function keys

F24 END OF JOB ends processing and causes the Resource Profile Management menu (AMLM30) to appear. The system ignores any information you typed on the display.

Fields

PLANNING WAREHOUSE. The first and succeeding warehouse identifiers in the range of planning warehouses you typed on display AMV3HI.

Contents	Index	Exit
--------------------------	-----------------------	----------------------

GENERATE ALL PROFILES <Y/N>. Type in **Y** to generate resource profiles for all master scheduled items, all production families, or both. Type in **N** to generate resource profiles only within range limits that you set.

Note: The system generates profiles only for master scheduled items and production families that are eligible to have profiles (RESOURCE PROFILE BUILD CODE = Y).

This field controls whether you generate all profiles or only selected profiles for the category (master scheduled items, production families, or both) you select at **GENERATE RESOURCE PROFILES FOR**.

KEEP USER CREATED/MAINTAINED PROFILES <Y/N>. Type in **Y** if you want this profile generation to save any changes you have made to resource profiles. If you type in **Y**, the system retains any changes to profiles and any profiles that you created using Resource Profile file maintenance (option 4 on the Resource Profile Management menu, AMLM30).

Type in **N** if you want the system to completely recalculate the resource profiles, deleting any changes you made or new profiles you created. If you type in **N** and you have made any changes to profiles, an informational message appears so that you must press **Enter** to continue processing.

Note: If you create a profile for an item or family and do not enter **Y** for **RESOURCE PROFILE BUILD CODE** in the item's Item Plan record, the system uses the profile for testing resources but ignores it whenever you generate profiles. No information about the profile appears in generation-related reports.

ENTER LEAD TIME DEVIATION PERCENT. Type in the lowest percent of difference between an item's calculated lead time and user-entered lead time that causes the item to print on the Resource Profile Exception Report (AML559). If you leave this field blank or type in zeros, the report contains lead times for each component item in every profile generated for a master scheduled item.

For a production family, leave this field blank. The system does not compare or print lead times or extended quantities for production families.

Note: When generating the resource profile for an item, the system calculates offsets for all of the component items, using routing and work center information. The offset is the number of days before the master scheduled end or component item is needed that its components or raw materials must be available or a necessary resource must be consumed if the item is to be completed and available on schedule.

The system compares this offset with the manufacturing lead time (LTMAN) for the component item in the Item Balance file. If the two values differ by the percent you specify on this display (AML501) or more, the item number and the two values print on the Resource Profile Exception Report (AML559).

Contents	Index	Exit
--------------------------	-----------------------	----------------------

GENERATE RESOURCE PROFILES FOR. Type in the number that identifies the kind of resource profiles you want to generate:

- 1** MASTER SCHEDULED ITEMS. Generates profiles for a single master scheduled item, a range of items, or all items assigned to a planner.
- 2** PRODUCTION FAMILIES. Generates profiles for a single production family, for a range of families, or for all families assigned to a planner.
- 3** BOTH. Generates all resource profiles for all eligible items and production families. If you select this method, you must type in Y for **GENERATE ALL PROFILES**. The system generates profiles for all items in the Item Plan file that have Y for **RESOURCE PROFILE BUILD CODE**.

PROFILES EFFECTIVE AS OF. Type in the effective date for including items in the calculation of family and item resource profiles. The system includes an item in the resource profile for its family if the date you enter here is between the schedule (PFD FM) and schedule to (PFD TO) dates you entered for the item during production family maintenance. The system includes a component item in the resource profile for its parent item's resource profile if the date you enter here is between the effective date from (EDAT M) and the effective date to (EDAT O) entered for the component in the Product Structure file. The default for this field is the system date (today's date).

AML502—Generate Resource Profiles Family Selection

Use this display to specify the range and limits for the production family resource profiles you want to generate, within the selected range of planning warehouses.

This display appears when you select method 2 (production families) for generating resource profiles on the Generate Resource Profiles Selection display (AML501).

When you select a range of production families and press **Enter**, additional fields appear at the bottom of the display so that you can specify limits.

```

DATE **/**/**          GENERATE RESOURCE PROFILES          AML502 **
                        FAMILY SELECTION

GENERATE RESOURCE PROFILES FOR
1 ONE PRODUCTION FAMILY
2 A RANGE OF PRODUCTION FAMILIES
3 ALL PRODUCTION FAMILIES FOR ONE PLANNER

SELECTION  n

F19 RETURN TO SELECT
F24 END OF JOB

NUMBER  aaaaaaaaaA15

F19 RETURN TO SELECT

RANGE  aaaaaaaaaA15
       aaaaaaaaaA15

F19 RETURN TO SELECT

PLANNER  nnnn

F19 RETURN TO SELECT
    
```

What to do

- To generate resource profiles by family, type in the information requested and press **Enter**. One or more additional fields appear at the bottom of the display to let you specify limits. Type in the additional information and press **Enter** again Go to display AML508.
- To change your selections for this profile generation, use **F19** and go to display AML501.

Contents	Index	Exit
--------------------------	-----------------------	----------------------

Function keys

F19 RETURN TO SELECT causes the Generate Resource Profiles Selection display (AML501) to appear if **SELECTION** appears at the bottom of the display. **F19** causes **SELECTION** to appear again if NUMBER, RANGE, or PLANNER appears at the bottom of the display. The system ignores any information you typed on the display.

F24 END OF JOB ends processing and causes the Resource Profile Management menu (AMLM30) to appear. The system ignores any information you typed on the display.

Fields

[\[?\]](#) appears next to a field name in the following field definitions to identify a field from which you can begin a master file search.

GENERATE RESOURCE PROFILES FOR. These fields list the ranges you can use for generating profiles:

- 1 ONE PRODUCTION FAMILY. Profiles are generated for a single production family. If you type in 1 and press Enter, you can also type in the number of the family.
- 2 A RANGE OF PRODUCTION FAMILIES. Profiles are generated for all production families with numbers within the limits you set. If you type in 2 and press Enter, you can also type in the range limits.
- 3 ALL PRODUCTION FAMILIES FOR ONE PLANNER. Profiles are generated for all production families assigned to a specific planner. If you type in 3 and press Enter, you can also type in the number of the planner.

SELECTION. Type in the number that identifies the range you want to use for generating resource profiles.

NUMBER. This field appears if you typed in 1 (one production family) for **SELECTION**. Type in the number of the production family for which you want to generate a resource profile, and press **Enter** again.

RANGE. This field appears if you typed in 2 (a range of production families) for **SELECTION**. Type in the beginning and ending numbers of the range of production families for which you want to generate profiles, and press Enter again.

Notes:

1. If you leave **NUMBER** and **RANGE** fields blank, the system generates profiles for all production families.
2. If you type a number into the first field only, the system generates profiles for that family and all families with higher numbers.
3. If you type a number into the second field only, the system generates profiles for that family and all families with lower numbers.

Contents	Index	Exit
--------------------------	-----------------------	----------------------

PLANNER. This field appears if you typed in 3 (all production families for one planner) for **SELECTION**. Type in the number of the planner for whose families you want to generate profiles, and press **Enter** again.

If there are no errors, pressing **Enter** again causes display AML508 to appear so you can submit the job to the job queue. The Resource Profile Management menu (AMLM30) appears.

AML503—Generate Resource Profiles Item Selection

Use this display to specify the range and limits for the item resource profiles you want to generate within the selected range of planning warehouses.

This display appears when you select method 1 (Master Scheduled Items) for generating resource profiles on the Generate Resource Profiles Selection display (AML501).

When you select a range of items and press **Enter**, additional fields appear at the bottom of the display so that you can specify limits.

```

DATE **/**/**          GENERATE RESOURCE PROFILES          AML503 **
                        ITEM SELECTION

GENERATE RESOURCE PROFILES FOR
1 ONE ITEM
2 A RANGE OF ITEMS
3 ALL ITEMS FOR ONE PLANNER

SELECTION n

F19 RETURN TO SELECT
F24 END OF JOB

NUMBER aaaaaaaaaA15

F19 RETURN TO SELECT

RANGE aaaaaaaaaA15
      aaaaaaaaaA15

F19 RETURN TO SELECT

PLANNER nnnn

F19 RETURN TO SELECT
    
```

What to do

- To generate resource profiles by item, type in the information requested and press **Enter**. One or more additional fields appear at the bottom of the display to let you specify limits. Type in the additional information and press **Enter** again. Go to display AML508.
- To change your selections for this profile generation, use **F19** and go to display AML501.

Contents	Index	Exit
--------------------------	-----------------------	----------------------

Function keys

F19 RETURN TO SELECT causes the Generate Resource Profiles Selection display (AML501) to appear if **SELECTION** appears at the bottom of the display. **F19** causes **SELECTION** to appear again if NUMBER, RANGE, or PLANNER appears at the bottom of the display. The system ignores any information you typed on the display.

F24 END OF JOB ends processing and causes the Resource Profile Management menu (AMLM30) to appear. The system ignores any information you typed on the display.

Fields

[\[?\]](#) appears next to a field name in the following field definitions to identify a field from which you can begin a master file search.

GENERATE RESOURCE PROFILES FOR. These fields list the ranges you can use for generating profiles:

- 1 ONE ITEM. Profiles are generated for a single master scheduled item. If you type in 1 and press **Enter**, you can also type in the number of the item.
- 2 A RANGE OF ITEMS. Profiles are generated for all master scheduled items with numbers within the limits you set. If you type in 2 and press **Enter**, you can type in the range limits.
- 3 ALL ITEMS FOR ONE PLANNER. Profiles are generated for all master scheduled items assigned to a specific planner. If you type in 3 and press **Enter**, you can also type in the number of the planner.

Note: You can generate a profile for a single item even if you did not enter Y for **RESOURCE PROFILE BUILD CODE** in the item's Item Plan file record. However, if you generate profiles for a range of items, the system generates profiles only for items that have Y for **RESOURCE PROFILE BUILD CODE**.

SELECTION. Type in the number that identifies the range you want to use for generating resource profiles.

If there are no errors, pressing **Enter** causes one or more entry fields to appear at the bottom of the display so that you can define the ranges further:

NUMBER. This field appears if you typed in 1 (one item) for **SELECTION**. Type in the number of the master scheduled item for which you want to generate a resource profile, and press Enter again.

RANGE. This field appears if you typed in 2 (a range of items) for **SELECTION**. Type in the beginning and ending numbers of the range of master scheduled items for which you want to generate profiles, and press Enter again.

Notes:

1. If you leave the **NUMBER** and **RANGE** fields blank, the system generates profiles for all master scheduled items.
2. If you type a number into the first field only, the system generates profiles for that item and all items with higher numbers.
3. If you type a number into the second field only, the system generates profiles for that item and all items with lower numbers.

Contents	Index	Exit
--------------------------	-----------------------	----------------------

PLANNER. This field appears if you typed in 3 (all items for one planner) for **SELECTION.** Type in the number of the planner for whose items you want to generate profiles, and press **Enter** again.

If there are no errors, pressing **Enter** again causes display AML508 to appear so you can submit the job to the job queue. The Resource Profile Management menu (AMLM30) appears.

If there are errors, this display (AML503) appears again with error messages. The fields in error are highlighted. Correct the errors and press **Enter** to submit the job to the job queue.

AML508—Resource Profile Generation Submit

Use this display to start the resource profile generation for the selected planning warehouse.

This display appears when you press **Enter** on display AML501 (if all resource profiles are generated), AML502, or AML503.

```

DATE  **/**/**          GENERATE RESOURCE PROFILES          AML508  **
                        RESOURCE PROFILE GENERATION SUBMIT

You can select a specific date and time
to start the resource profile generation.

To start the generation now,
press ENTER.

To start the generation later,
enter a date and time:

DATE  nnnnnn
TIME  nnnnnn

F18 REFRESH
F24 END OF JOB
    
```

What to do

- To start the resource profile generation, accept the defaults or type in the date and time you want the job to start. The system submits the job to the job queue. When generation is complete, a Resource Profile Report (AML559) for each planning warehouse selected is printed.
- To end the session without starting a resource profile generation, use **F24**.

Function keys

F18 REFRESH restores the display to its status before you made any changes.

F24 END OF JOB ends processing and causes the Resource Profile Management menu (AMLM30) to appear. The system cancels the resource profile generation.

Fields

DATE. Accept the default of the current system date or type in the date you want to start the job.

TIME. Accept the default of the current system time or type in the time you want to start the job.

Option 4. Display and Maintain Resource Profiles

Use this option to:

- Review information about the resources included in a resource profile
- Add a resource to a resource profile
- Change or delete a resource in a resource profile
- Create a resource profile that was not generated
- Delete all resources for a resource profile.

What information you need:

- The identifier of the planning warehouse in which the item or production family resides
- The number of the item or production family whose resource you want to review
- The resource number, offset, quantity used, and quantity value for any resource you want to add

Note: Any resource you add must also exist in the Resource Master file. Use Resource Master file maintenance, option 1 on the Resource Profile Management menu (AMLM30).

- The offset, quantity used, and quantity value for any resource you want to change.

What reports are printed: None.

What forms you need: None.

The basic steps to display and maintain resource profiles follow each display.

AML511—Display/Maintain Resource Profiles Selection

Use this display to select the production family or master scheduled item and the planning warehouse in which it resides for which you want to review, change, delete, or create a resource profile.

Note: You must be authorized to the proper level of security in the warehouse you select.

This display appears when you:

- Select option 4 on the Resource Profile Management menu (AMLM30)
- Use **F02 RESTART** on the Display/Maintain Resource Profiles display (AML512)
- Use **F11 DEL (Delete) PROFILE** on display AML512.

DATE **/**/**	DISPLAY/MAINTAIN RESOURCE PROFILES SELECTION	AML511 **
	PLANNING WAREHOUSE	aA3
	PRODUCTION FAMILY NUMBER OR MASTER SCHEDULED ITEM NUMBER	aaaaaaaaaaaaA15 aaaaaaaaaaaaA15
F24 END OF JOB		

What to do

- To review or change a resource profile, type in the number of the item or production family whose profile you want to see and press **Enter**. Go to display AML512.
- To create a resource profile, type in the number of the item or production family whose profile you want to create and press **Enter**. The Display/Maintain Resource Profiles display (AML512) appears, with addition fields at the bottom of the display. Do one of the following:
 - To add a resource, type in the required information and press **Enter**.
Note: To cancel the addition, press any function key shown and do not press **Enter**.
 - To start the inquiry again, use **F03** and go to display AML512.
 - To change or delete a resource for this profile, use **F05**.

Contents	Index	Exit
--------------------------	-----------------------	----------------------

Function keys

F24 END OF JOB ends processing and causes the Resource Profile Management menu (AML30) to appear. The system ignores any information you typed on the display.

Fields

[\[?\]](#) appears next to a field name in the following field definitions to identify a field from which you can begin a master file search.

PLANNING WAREHOUSE [?]. Type in the identifier of the planning warehouse you want to use.

PRODUCTION FAMILY NUMBER [?] OR MASTER SCHEDULED ITEM NUMBER [?]. Type in the number of the production family or master scheduled item for which you want to review, change, delete, or create a resource profile. You can make an entry in only one field.

Contents	Index	Exit
--------------------------	-----------------------	----------------------

AML512—Display/Maintain Resource Profiles

Use this display to show the current resource profile for the family or item you selected. If the profile is generated, it is for a standard batch quantity or standard lot size of an item; it is for a calculated composite lot size for a production family. The display lets you review, change, or delete an existing profile, or create a new one.

This display appears when you select option 4 on the Resource Profile Management menu (AML30) and enter a valid production family number or master scheduled item number on display AML511.

On this display, you can:

- Review the current resource profile for the item or family
- Change the offset, resource identification number, quantity, or value for any resource in the profile
- Add resources to the profile, or delete resources from it
- Create a resource profile by adding resources
- Delete the complete profile.

The system uses resource profiles to calculate the quantity, timing, and value of critical resources required to meet the production goals for one or more families or to meet your combined master production schedules. If you typed in Y for **RESOURCE PROFILE BUILD CODE** in the Item Plan file record for the item or family, the system can generate a profile for it. If you typed in N, you can still create your own profile for the item or family by adding the resources yourself.

You can use this display to adjust a generated profile or to create a profile if no generated one exists. The system can save your changes and special profiles when it generates profiles again, or it can erase them if you choose.

Note: You can create a resource profile for an item or family that is not coded for a generated resource profile (RESOURCE PROFILE BUILD CODE = N). You can also generate a profile for a single master scheduled item that is not coded for generation. The system ignores those profiles during later generations; it does not change or delete them. However, if you later request a generated profile for that family or item and do not specify keeping all user changes (KEEP USER CREATED/MAINTAINED PROFILES = N), the system deletes the existing profile, including any changes or additions you made.

Only a resource that you entered in the Resource Master file can appear in a resource profile. If you identify a new resource that you want the system to include in generated profiles, or if you want a resource deleted from all generated profiles, you must:

- Add or delete the resource in the Resource Master file
- Add or delete the resource number in the Item Plan file or the Production Facility file if the resource is an item or a work center
- Generate resource profiles again for all items or families that use the resource.

```

DATE **/**/**          DISPLAY/MAINTAIN RESOURCE PROFILES          AML512 **
MASTER SCHEDULED ITEM *****          EFFECTIVE DATE **/**/**
DESCRIPTION *****          STD BATCH **,**,**,**
OFF -----RESOURCE-----
SQ  SET  ID  U/M  QUANTITY  VALUE  SOURCE  MAINT/
**  **.* ***** ** ** ** ** ** ** ** ** ** ** ** ** ** ** ** ** ** ** ** ** ** ** ** ** ** **   ** **/**/**
*****

*****          INQUIRY          F02 RESTART          F11 DEL PROFILE
          F05 CHG/DELETE          F12 ADDL FIELDS
          F08 ADD          F24 END OF JOB

          ADDITION
OFFSET nnn.n ID nnnnn QTY nnnnnnnn.nnnnn VAL nnnnnnnnnn.nnn F03 RESUME INQ
          F05 CHG/DELETE

          ACTION A 'C'-CHANGE 'D'-DELETE          F03 RESUME INQ
OFFSET nnn.n ID nnnnn QTY nnnnnnnn.nnnnn VAL nnnnnnnnnn.nnn F05 CHG/DELETE
          F08 ADD

          SELECTION
ENTER SQ nn          F03 RESUME INQ
          F08 ADD
    
```

What to do

- To review more resources for this profile, press **Enter**. More resources exist if CONTINUED appears in the lower left of the display.
- To add a resource to this profile or create the profile by adding a resource, use **F08**. Additional fields appear at the bottom of the display. Do one of the following:
 - To add a resource, type in the required information and press **Enter**. To cancel the addition, press any function key shown and do not press **Enter**.
 - To start the inquiry again, use **F03**.
 - To change or delete a resource for this profile, use **F05**.

Contents	Index	Exit
--------------------------	-----------------------	----------------------

- The ENTER SQ (Sequence Number) prompt appears at the bottom of the display. Do one of the following:
 - To change or delete a resource, type in the information requested and press **Enter**.
 - Additional fields appear at the bottom of the display. Type in **1** (change) for ACTION, and type in any information you want to change. Type in **2** (delete) for **ACTION** and press **Enter**. An informational message appears. Changing **OFFSET** for a usage in a generated profile can result in duplicate records. See the display description for display AML512 for a full explanation. Then do one of the following:
 - To complete the change or deletion, press **Enter** and return to discussion on changing or deleting a resource.

Note: To cancel the change or deletion, press any function key shown and do not press **Enter**.
 - To start the inquiry again, use **F03** and go to display AML512.
 - To start another change or deletion, use **F05** and return to previous discussion on changing or deleting a resource.
 - To add a resource to this profile, use **F08** and return to discussion on adding a resource.
- To review the resources in another profile, use **F02** and go to display AML511.
- To delete all resources from this profile, use **F11**. An informational message appears at the bottom of the display. Do one of the following:
 - To complete the deletion, use **F11**. Go to display AML511. To cancel the deletion, press **Enter** or any function key shown except **F11**.
 - To review more resources for this profile, press **Enter**. More resources exist if CONTINUED appears in the lower left of the display. Go to display AML512.
 - To add a resource to this profile, use **F08** and return to discussion on adding a resource.
 - To change or delete a resource for this profile, use **F05** and return to discussion on changing or deleting a resource.
 - To review a different profile, use **F02** and go to display AML511.
 - To end this session, use **F24**.
- To display or not display the resource description, use **F12**.
- To end the session, use **F24**.

Function keys

F02 RESTART causes the Display/Maintain Resource Profiles Selection display (AML511) to appear so that you can select another item or family profile to review. This function key appears only when the display is in Inquiry mode.

Contents	Index	Exit
--------------------------	-----------------------	----------------------

F03 RESUME INQ causes display AML512 to appear again with the body updated to show any changes you made. This function key does not appear when the display is in Inquiry mode.

Note: The following two function keys let you add, change, or delete resources for this profile. Entry fields appear at the bottom of the display so that you can select a resource, select the kind of action, and type in new or changed information. For the system to accept anything you type in, you must press **Enter** before you press another function key. If you do not, the system ignores what you typed on the display and begins the new action, canceling the previous action.

F05 CHG/DELETE causes the **SQ** (Sequence Number) field to appear at the bottom of the display. Type in the sequence number of the resource you want to change or delete and press Enter. Additional fields appear at the bottom of the display. Current information about the item you selected appears in the fields for you to review or change.

F08 ADD causes entry fields to appear at the bottom of the display so that you can add a resource to this profile:

After you press **Enter**, the entry fields appear again so that you can add another resource.

F11 DEL PROFILE deletes the profile from the Resource Profile file. An informational message appears. Use **F11** again to complete the deletion, or use any other function key shown or **Enter** to cancel the deletion. If you complete the deletion, the Selection display (AML511) appears. If you cancel the deletion, the action you use (function key or Enter) determines which display appears next. This function key appears only when the display is in Inquiry mode.

F12 ADDL FIELDS (Additional Fields) causes the resource descriptions to display or not display.

F24 END OF JOB ends processing and causes the Resource Profile Management menu (AMLM30) to appear. The system ignores any information you typed on the display.

Fields

[\[?\]](#) appears next to a field name in the following field definitions to identify a field from which you can begin a master file search.

MASTER SCHEDULED ITEM (ITNBR). The number that you entered on the Display/Maintain Resource Profiles Selection display (AML511). The number appears on the right side of the field. The left side of the field shows MASTER SCHEDULED ITEM if you entered an item number, or PRODUCTION FAMILY if you entered a family number.

EFFECTIVE DATE (RPDTE). The date that determined whether end items could be included in their family's resource profile or whether component items could be included in their parent's resource profile. To be included, an end item's from and to dates for assignment to its family must include this date, and a component item's product structure effectivity dates must include this date. This is the date you typed in for **PROFILE EFFECTIVE AS OF** on display AML501, Generate Resource Profiles Selection. If you added this profile or maintained all the resources in a generated profile, USER appears instead of a date.

Contents	Index	Exit
--------------------------	-----------------------	----------------------

DESCRIPTION (ITDSC). A description of the master scheduled item or production family.

STD BATCH (Standard Batch Quantity) (SBQTY). The amount of this item that the system uses to calculate the required quantities for components. This heading appears for a master scheduled item that uses a standard batch quantity. LOT SIZE (LOTSZ) appears for an item that uses a standard lot size. COMPOSITE appears for a production family. The system calculates a composite lot-size quantity to use in testing for family-level resource needs. If a production family does not have a generated profile, the composite lot size is one.

The following fields appear in the body of the display. Resources appear in order by offset, starting with the largest negative offset, and by resource number within offset.

If CONTINUED appears in the lower left of the display, more resources exist than can appear at one time. Press **Enter** to see the next set.

The fields shown in the body of the display are for information only; you cannot change them by typing over them. To add, change, or delete a resource, you must use the function keys at the bottom of the display.

SQ (Sequence Number). A system-generated number that you can use to identify a resource you want to change or delete.

OFF SET (RPOFS). The number of days before or after the due date or production period date that a resource is needed (available or consumed). For a generated profile the system calculates the offsets using a forward scheduling technique similar to those in the Production Control and Costing (PC&C) worklist generation program.

A negative offset appears when:

- The system calculates a lead time for the item greater than the user-entered lead time (LTMAN) stored in the Item Balance file
- You enter a negative offset to show that the resource is consumed or becomes available after the item is produced (for example, money received from the sale of a product).

Large negative offsets calculated by the system may signal inaccurate or unrealistic item lead times in your master files. Inaccurate lead times cause inaccurate resource profiles and may cause unrealistic order scheduling when you generate master schedules.

RESOURCE ID (Resource Number) (RMRSC). The unique identifying number you assigned to this resource.

RESOURCE U/M (Unit of Measure) (RMUOM). The code for the unit used in measuring this resource. Your company establishes this code.

RESOURCE QUANTITY (RPQTY). The quantity of the resource to be used for a standard batch or lot of this item at the offset shown. If the quantity is too large to appear in this field, the system shows all 9s for the quantity.

RESOURCE VALUE (RPVAL). The cost of the resource quantity to be used. If the quantity is too large to appear in this field, the system shows all 9s for the quantity.

Contents	Index	Exit
--------------------------	-----------------------	----------------------

SOURCE (Profile Source) (RPSRC). The source of each resource usage shown in the profile. G appears if the system generated the resource; U appears if a user entered or changed the resource.

MAINT/CREATED (RPDTE). The date when you last maintained the resource usage or when you added it. If the system generated the profile and you have not changed it, this field shows the generation date.

Resource Description (RMDES). A description of this resource. This description is the description you entered using Resource Master file maintenance.

CONTINUED/END. If CONTINUED appears at the lower left of the display, pressing **Enter** shows you more resources for this profile. If END appears at the lower left, pressing **Enter** shows you the first resources again.

ACTION. Type in **1** (change) to change information about a resource. Type in **2** (delete) to delete a resource from the profile. If you type in 1 you can type new information into the other entry fields. If you type in 2, the system ignores any information you type in. When you press **Enter**, a message tells you to press **Enter** again to complete the deletion.

OFFSET. Type in the number of days before or after the due date that this resource is needed or is becoming available. Enter a negative offset if the resource is used or becomes available after the due date.

ID (Resource Number) (RPRSC) [?]. Type in the number identifying the resource you want to add. You assigned this number to the resource when you entered it in the Resource Master file.

QTY (Quantity). Type in the changed quantity of this resource needed or available at the offset shown.

VAL (Value) (RPVAL). Type in the cost of the resource quantity you typed for the previous field.

ENTER SQ. Type in the sequence number.

Contents	Index	Exit
--------------------------	-----------------------	----------------------

Option 5. Item Resource Report (AML30)

Use this option to print the Item Resource Report (AML321 for a selected range of planning warehouses.

What information you need:

The planning warehouses for which you want to print the report

What report is printed:

Item Resource Report (AML321).

What forms you need: None.

The basic steps to print the Item Resource Report are listed for each display.

AMV3HM—Item Resource Report Options

Use this display to select for which planning warehouses the item resource report will be generated. You can select a single planning warehouse, or a range of planning warehouses. For each warehouse that falls in the range selected, separate jobs are initiated and separate reports are printed.

Note: You must be authorized to the proper level of security in the warehouses you select.

This display appears when you select option 5 on menu AMLM30.

For the **From** and **To** ranges on this display, the value you type in the **To** field must be greater than or equal to the value you type in the **From** field when both fields are used. The range begins with and includes the value you type in the **From** field; it ends with and includes the value you type in the **To** field.

If you type a value in the **From** field only, the system ends the range with the highest value for that field. If you type a value in the **To** field only, the system begins the range with the lowest value for that field. If you want to select records by a single value instead of a range, use that value in both the **From** and **To** fields.

AMV3HM Item Resource Report Options

Planning warehouse limits

From warehouse aA3

To warehouse aA3

F1=Help F5=Refresh F24=Cancel

What to do

- To proceed, select a range of planning warehouses and press **Enter**. Display AMV3A1 appears for you to limit the items that appear on the report.
- To cancel the session, use **F24**. Menu AMLM30 appears again.

Function keys

F1=Help shows information about this display. Pressing **F1** or pressing the **help** key shows you the same information.

F5=Refresh restores the display to its status before you made any changes.

Contents	Index	Exit
--------------------------	-----------------------	----------------------

F24=Cancel ends processing and any data you typed is ignored. The Master Schedule Planning menu (AMLM20) appears again.

Fields

[?] appears next to a field name in the following field definitions to identify a field from which you can begin a master file search.

Planning warehouse limits.

From warehouse/To warehouse [?]: The range of warehouses to use for this task.

AMV3A1—Item Resource Report Options

Use this display to limit the Item Resource Report (AML321) to include only items that are not already assigned to a production family or to include both assigned and unassigned items in the range of warehouses you selected. You also use this display to begin printing the report.

This display appears when you press **Enter** on display AMV3HM. When you type in an acceptable response and press **Enter**, the system submits the print job for the Item Resource Report (AML321) to the job queue.

The Item Resource Report can include only end items with resource profiles. For each item included, the report prints the five highest-valued critical resources the item uses, listed in descending order.

Note: The values shown are for a standard lot size or standard batch quantity of the item. Value (resource quantity multiplied by its cost) provides a common unit of measure for resources that have more than one unit of measure, such as pounds and ounces, based on where they are used.

DATE **/**/** ITEM RESOURCE REPORT OPTIONS AMV3A1 **

DO YOU WANT TO BYPASS ITEMS THAT ARE
ALREADY ASSIGNED TO A PRODUCTION FAMILY? <Y/N> A

F24 END OF JOB

What to do

- For the Item Resource Report to be printed, type in the requested information and press **Enter**. The system submits the job to the job queue.
- To end the job without the report being printed, use **F24**.

Function keys

F24 END OF JOB ends processing and causes the Resource Profile Management menu (AMLM30) to appear. The system ignores any information you typed on the display.

Contents	Index	Exit
--------------------------	-----------------------	----------------------

Fields

DO YOU WANT TO BYPASS ITEMS THAT ARE ALREADY ASSIGNED TO A PRODUCTION FAMILY? <Y/N>. Type in **Y** to include in the report only master scheduled items that are not already assigned to a production family. Type in **N** to include all master scheduled items in the report.

Note: To be included in the report, an item must be an end item and must have a resource profile.

Chapter 6. Available to Promise

Use this option on the Main Menu (AMLM00) to see the uncommitted quantities for an item that is available in inventory for each period. A selection display (AML490) lets you select the item to review; then an inquiry display shows you the available to promise quantities and supporting information. The system calculates the quantities at the time of inquiry.

Option 4. Available to Promise (AMLM00) 6-2

These displays also appear when you select option 6 on the Master Schedule Planning menu (AMLM20).

Option 4. Available to Promise (AML00)

Use this option to look at the uncommitted quantities of an item that are available to promise.

What information you need:

- The number of the item for which you want to see available to promise information.
- Whether to include generated demand from MRP or not.
- The warehouse ID for the desired item.

What reports are printed: None.

What forms you need: None.

The displays used in this option are described in Chapter 4, "Master Schedule Planning". See "AML490—Available to Promise Item Selection", "AMVATP03—Display Available to Promise", and "AMVATP05—Display Available to Promise" for field descriptions.

Contents	Index	Exit
--------------------------	-----------------------	----------------------

Chapter 7. Change/Display Horizon Dates

Use this menu option on the Main Menu (AMLM00) to review the horizon dates, by planning warehouse, used for the last master schedule planning run, set new dates for the next planning run, review reference dates for your production plans, and set a new period beginning date for your family operating plans and item production plans.

Option 5. Change/Display Horizon Dates (AMLM00) 7-1

Option 5. Change/Display Horizon Dates (AMLM00)

Use this menu option to:

- Review the horizon dates used for the last master schedule planning run
- Set new dates for the next planning run
- Review reference dates for your production plans
- Set a new period beginning date for your family-level production plans.

What information you need:

- The planning warehouse in which you want to change or display horizon dates
- A new current date for the master production schedules
- A new number of cutoff weeks for master scheduling
- A new Operating Plan Date for the next production planning aggregation.

What reports are printed: None.

What forms you need: None.

The basic steps to change and display horizon dates follow each display.

Contents	Index	Exit
--------------------------	-----------------------	----------------------

AMV36F—Change/Display Horizon Dates

Use this display to select the planning warehouse in which you want to change or display horizon dates.

Note: You must be authorized to the proper level of security in the warehouse you select.

This display appears when you select option 5 on the main menu AMLM00.

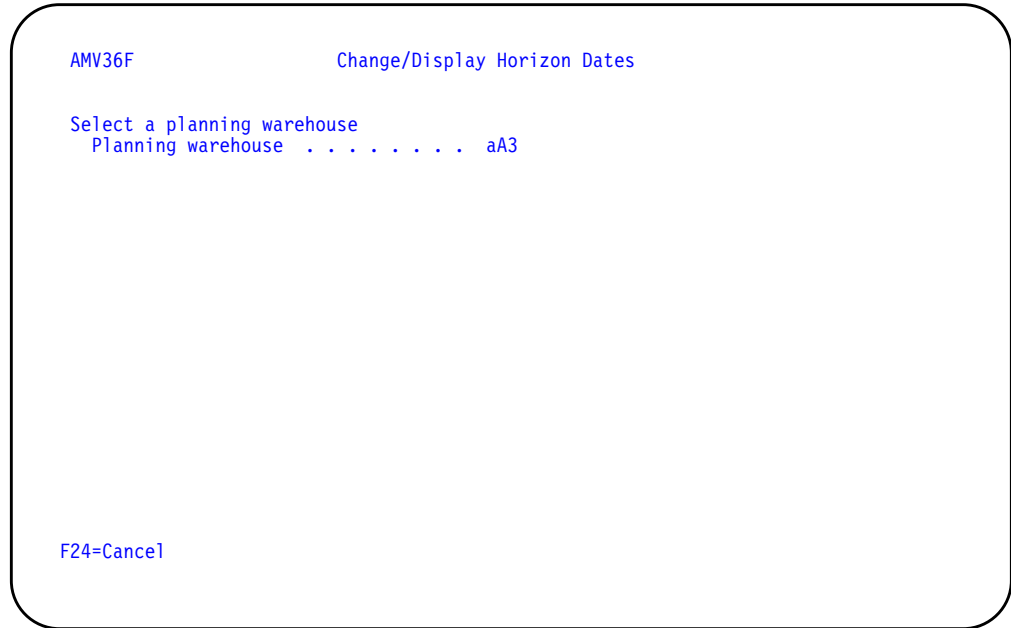

What to do

- To proceed to the change/display horizon dates display, type the planning warehouse number and press **Enter**. Display AML601 appears.
- To cancel the session, use **F24**. Menu AMLM00 appears again.

Function keys

F24=Cancel ends processing and any data you typed is ignored. The Main Menu (AMLM00) appears again.

Fields

[?] appears next to a field name in the following field definitions to identify a field from which you can begin a master file search.

Planning warehouse [?]. Type the number of the planning warehouse you want to use.

AML601—Change/Display Horizon Dates

Use this display to show, for the selected planning warehouse, the planning dates and the number of weeks you included in the previous master schedule generation, along with the dates you used for setting up your production plans. The display lets you set new dates for the next master schedule generation and set a new starting date for your family-level production plans.

This display appears when you press **Enter** on display AMV36F.

On this display, you can:

- Review the planning dates used for the last master production schedule generation (planning run)
- Enter new planning dates for the next master schedule planning run (New MPS Current Date and Number of Cutoff Weeks) and accept the new dates
- Review reference dates used in production planning
- Enter a new starting date for family-level production planning (New Operating Plan Date) and accept the new date
- End the job (**F24**) without accepting the new master scheduling dates or the new production planning date.

```

DATE **/**/**          CHANGE DISPLAY HORIZON DATES          AML601  **

MPS PLANNING DATES          PRODUCTION PLANNING DATES
MPS CURRENT DATE          **/**/**          ITEM PRODUCTION PLAN DATE  **/**/**
CUTOFF DATE                **/**/**          DEMAND FILE DATE          **/**/**
NEW MPS CURRENT DATE      **/**/**          BASE PLAN DATE            **/**/**
NEW CUTOFF DATE           **/**/**          OPERATING PLAN DATE       **/**/**
NEW OPERATING PLAN DATE   **/**/**

DISPLACEMENT
CUTOFF WEEKS              ***

                          WAREHOUSE ***

ENTER NEW MPS CURRENT DATE          nnnnnn
ENTER NUMBER OF CUTOFF WEEKS        nnn
ENTER NEW OPERATING PLAN DATE       nnnnnn

F17 ACCEPT FOR UPDATE
F24 END OF JOB
    
```

Contents	Index	Exit
--------------------------	-----------------------	----------------------

What to do

The fields in the upper part of the display show the current horizon dates and production planning dates. Entry fields are at the bottom of the display. Do one of the following:

- To change the master schedule horizon dates, type in the information requested in the first two entry fields at the bottom of the display and press **Enter**. The Change/Display Horizon Dates display (AML601) appears again. Some fields at the top of the display show new information based on the information you typed in, and **F17** appears at the bottom of the display. Do one of the following:
 - To accept the new dates you typed on the display, use **F17**.
 - To change the information again, type new information into the fields at the bottom of the display and press **Enter**.
- To change the operating plan date for the next aggregation, type in the information requested in the third entry field at the bottom of the display and press **Enter**. The Change/Display Horizon Dates display (AML601) appears again. Some fields at the top of the display show new information based on the information you typed in, and **F17** appears at the bottom of the display. Do one of the following:
 - To accept the new dates you typed on the display, use **F17**.
 - To change the information again, type new information into the fields at the bottom of the display and press **Enter**.

Function keys

F17 ACCEPT FOR UPDATE (appears only after you press **Enter**) updates the System Control file with any new information you entered on the display. The system uses the new information for the next master schedule generation or the next aggregation. The Main Menu (AMLM00) appears.

F24 END OF JOB ends processing and causes the Main Menu (AMLM00) to appear. The system ignores any information you typed on the display and does not record the changes.

Fields

The fields on the upper half of the display are for information only. The fields on the left show information about your master production schedules; the fields on the right show information about your production plans.

Some of the fields do not change until you generate master schedules, replace production plans, update demand files, or aggregate. Other fields change if you type in new information at the bottom of the display. You can use those fields to see the results of new scheduling dates that you enter; then you can change the dates if they are not acceptable.

Contents	Index	Exit
--------------------------	-----------------------	----------------------

MPS (Master Production Schedule) PLANNING DATES.

MPS CURRENT DATE (MPCU): The MPS Current Date used in generating your present master production schedules. This field changes when you generate master schedules using a new current date.

CUTOFF DATE (MPCO): The last day in your present master scheduling horizon. The system did not plan periods after that date. This field changes when you generate master schedules using a new current date.

NEW MPS CURRENT DATE (MPPU): The date which identifies the current period in your next master production schedules if you use **F17** to accept the date. If you type an acceptable new current date into the entry field at the bottom of the display and press **Enter**, the date appears here.

NEW CUTOFF DATE: The date when master scheduling ends in your new master production schedules if you use **F17** to accept the date. The system does not plan periods after the cutoff date.

You set this date by the number of cutoff weeks you enter below: the cutoff date is that many weeks after the current date. The system recalculates this field each time you type in a new number of cutoff weeks or a new current date in the entry fields at the bottom of the display and press **Enter**.

DISPLACEMENT.

CUTOFF WEEKS (MPCW): The number of weeks between the master schedule current date and the end of the planning horizon. When the display appears, this field shows the number of weeks in your current master production schedules. This field changes when you type in a new number in **ENTER NUMBER OF CUTOFF WEEKS** at the bottom of the display.

PRODUCTION PLANNING DATES.

ITEM PRODUCTION PLAN DATE (FPPD): The beginning date of the first period in the Item Production Plan file. You set this date each time you replace all item production plans (option 7 on the Production Planning menu, AMLM10).

DEMAND FILE DATE (FDPD): The beginning date of the first period containing forecasts or customer orders in the Demand Interface file. You set this date each time you load forecasts or backlog into the file.

BASE PLAN DATE (BPDT): The beginning date of the first period in your family base plans. This date was the Operating Plan Date when you replaced all family base plans with current family operating plans.

OPERATING PLAN DATE (OPDT): The beginning date of the first period in the current family operating plans. The system resets this date during aggregation. It becomes the beginning date for item production plans when you replace all item plans. This date was the New Operating Plan Date you typed in for the last aggregation.

Contents	Index	Exit
--------------------------	-----------------------	----------------------

NEW OPERATING PLAN DATE (PPDE): The beginning date for family-level production plans when you aggregate again if you use **F17** to accept this date. This field changes when you enter a new date in the **ENTER NEW OPERATING PLAN DATE** field at the bottom of the display. If you have not changed this date since the last aggregation, the date is the same as the **OPERATING PLAN DATE** field.

WAREHOUSE. The planning warehouse you selected on the previous display.

ENTER NEW MPS CURRENT DATE. Type in a date in the period you want as the current period in the new master production schedules. This date should be the first day of the next scheduling week.

The MPS current date serves as a reference date for coordinating the production schedules in MPSP and MRP. When the MRP current date is the same as the MPS current date, the component orders planned in MRP align exactly with the master scheduled orders transferred from MPSP.

Note: MPSP calculates the horizon start date for master scheduling the same way MRP calculates its start date. If you entered a value in the **OVERDUE DAYS (OVDP)** field in MRP, MPSP uses that number also. The system sets the start date for master scheduling to be that number of working days before the current date you enter on this display.

The dates you set on this display depend on your company's products and manufacturing practices. Some general guidelines are:

- The new MPS current date you set should be the same as the current date you set for the first MRP planning run that uses the master schedules from this generation.
- The number of cutoff weeks you set should be large enough to let you respond to significant changes in demand before they can disrupt the normal manufacturing schedule for your products.
- If you use production plans for scheduling some items, the item production plan date must be before or the same as the new MPS current date.
- If you use forecasts, customer orders (without having Order Entry and Invoicing installed and interfacing), or blended demand scheduling some items, the demand file date must be before or the same as the new MPS current date.
- The MPSP application lets you generate master schedules when you want, but it considers one week to be the normal interval. If you specify an interval greater or less than one week, an informational message appears. You must confirm the unexpected interval by pressing **Enter** to continue processing.
- For production planning, the item production plan date and the demand file date should be the same as or later than the base plan date.
- The new operating plan date you enter should be the same as or later than the item production plan date.

The dates that you change on this display are temporary unless you approve and accept the changes. When you press **Enter**, you see new dates in some fields. However, the system does not record those dates and does not use them unless you confirm them by using **F17**, which appears only after you press **Enter**.

Contents	Index	Exit
--------------------------	-----------------------	----------------------

ENTER NUMBER OF CUTOFF WEEKS. Type in the number of weeks to include in the master production schedules. This number should at least equal the number of weeks in the longest CMLT (cumulative material lead time) of any master scheduled item plus the number of weeks between your regular master schedule planning runs.

The system uses this number to calculate the cutoff date (horizon end date) for the master production schedules. The new cutoff date is this number of weeks after the new MPS current date you entered in the field above. When you press **Enter**, the calculated end date appears in the **NEW CUTOFF DATE** field at the top of the display.

Setting the cutoff date for master production scheduling lets you separate short-term materials and capacity planning from intermediate and long-term resource planning. The system does not plan periods after the cutoff date, but forecasts and other demand information can extend up to three years. You can use actual demand or demand projections after the cutoff date to do long-term production planning and resource testing.

ENTER NEW OPERATING PLAN DATE. Type in the beginning date of the first period to be included in the family-level production plans. If you replace all item production plans, they also begin at this date. The operating plan date used in the last aggregation appears as a default.

The date you enter must be a period beginning date. It should also be equal to or later than the following:

- The last Operating Plan Date
- The Item Production Plan Date
- The Demand File Date
- The Base Plan Date.

Note: The New Operating Plan Date should be the beginning date of the period in which you aggregate, and you should aggregate in the current period. If you enter the beginning date of any other period, informational messages appear before the system accepts the date.

When you type in a date and press **Enter**, the changed date appears in the **NEW OPERATING PLAN DATE** field in the heading.

Contents	Index	Exit
--------------------------	-----------------------	----------------------

Chapter 8. Report descriptions

This chapter contains samples of reports the MPSP application produces. Depending on decisions you make when you answer the questionnaire, some of the optional reports may not print. Your answers also affect the contents of some reports.

MPSP provides a variety of reports to help you create and manage your item production plans and master production schedules. Although most of the reports contain information you can see online using inquiry displays, the reports provide supporting information and a printed record that may be helpful for historical and comparative analysis.

Each report has a unique identification number in the upper right corner. The list below shows the identification number with the report name. You can use either the number or the name to identify a report. The report descriptions in this chapter are arranged in alphabetic order by report name.

If you selected a range of planning warehouses at run time, a separate report is printed for each warehouse that falls within that range. The warehouse identifier also appears on the report.

If EPDM is activated, the headings on the reports will use the EPDM Item Revision Master for the item description.

Table 8-1. MPSP reports sorted by report name

Report	ID	See page
Aggregation Error List	AML340	8-3
Family Operating Plan Report	AML271	8-4
Item Resource Report	AML321	8-8
Master Schedule Open Order Maintenance List	AML455	8-10
Master Schedule Planning Report	AML471	8-12
Planning Run Status Report	AML480	8-23
Replace Family Base Plans Error List	AML221	8-25
Replace Item Production Plans Error List	AML250	8-26
Resource Master File List	AML581	8-28
Resource Master File Maintenance Edit List	AML599	8-29
Resource Profile Exception Report	AML559	8-30

Table 8-2. MPSP reports sorted by report ID

ID	Report	See page
AML340	Aggregation Error List	8-3
AML271	Family Operating Plan Report	8-4
AML321	Item Resource Report	8-8
AML455	Master Schedule Open Order Maintenance List	8-10
AML471	Master Schedule Planning Report	8-12
AML480	Planning Run Status Report	8-23
AML221	Replace Family Base Plans Error List	8-25
AML250	Replace Item Production Plans Error List	8-26
AML581	Resource Master File List	8-28
AML599	Resource Master File Maintenance Edit List	8-29
AML559	Resource Profile Exception Report	8-30

Aggregation Error List (AML340)

NORTHCREEK IND. NO. 01 AGGREGATION ERROR LIST DATE 8/04/** TIME 16.59.08 PAGE 0001 AML340

WAREHOUSE ATL

FAMILY NO.	ITEM NO.	MESSAGES
COMPACT-PF	COMPACT2	W AM-8527 HELD INVENTORY NEGATIVE WITHIN HORIZON
COMPACT-PF	COMPACT3	W AM-8527 HELD INVENTORY NEGATIVE WITHIN HORIZON
COMPACT-PF	COMPACT1	W AM-8527 HELD INVENTORY NEGATIVE WITHIN HORIZON
COMPACT-PF		W AM-8536 NET DEMAND EXCEEDS PRODUCTION TARGETS
COMPACT-PF		W AM-8537 SAFETY STOCK EXCEEDS PROJECTED INVENTORY
SEDAN-PF	SEDAN3	W AM-8527 HELD INVENTORY NEGATIVE WITHIN HORIZON
SEDAN-PF	SEDAN2	W AM-8527 HELD INVENTORY NEGATIVE WITHIN HORIZON
SEDAN-PF	SEDAN1	W AM-8527 HELD INVENTORY NEGATIVE WITHIN HORIZON
SEDAN-PF		W AM-8536 NET DEMAND EXCEEDS PRODUCTION TARGETS
SEDAN-PF		W AM-8537 SAFETY STOCK EXCEEDS PROJECTED INVENTORY

This report identifies errors that occur when you choose option 1, Aggregate to Production Families, on the Production Planning menu (AMLM10). Aggregation accumulates your current inventory, demand, and production information at the item level into family-level totals.

This report is printed at the end of the aggregation process. Use it to review family, item, or file errors you may need to correct.

If you selected a range of planning warehouses, a separate report is printed for each warehouse that falls within that range. The warehouse identifier appears on the report.

Fields

WAREHOUSE. The identifier of the planning warehouse.

FAMILY NO. The number of each production family in which the system found an error during aggregation.

ITEM NO. The number of the item the system found in error during aggregation.

MESSAGES. Message number and text describing the error condition that occurred.

Date in error. The actual date and a description of the date that the system found in error during aggregation. This field is printed only if a date is in error.

FILE. The name of the file from which the system was attempting to retrieve information when the error occurred. This field appears only if the error requires the additional information.

KEY. The key field of the index file that the system uses at the time of the error. This field appears only if the error requires the additional information.

NO ERRORS WERE FOUND. Indicates that no errors occurred during aggregation; appears only if no error messages are printed on the report.

Family Operating Plan Report (AML271)

NORTHCREEK IND. NO. 01 FAMILY OPERATING PLAN REPORT UNITS DATE 8/04/** TIME 14.41.43 PAGE 2 AML271

WAREHOUSE ATL

FAMILY ON HAND PERIODS	SEDAN-PF 12- 8/04/**	DESC SAFETY 9/01/**	SEDAN AUTO 10/06/**	PROD 11/03/**	FAMILY HELD 12/01/**	0 1/05/**	BALANCE 2/02/**	3/02/**	4/06/**	12- 5/04/**	SIGNIFICANCE (RATE/DAY) 6/01/**	2,000 7/06/**
BUILD +/-	199	221	82-	156-	136-	216-	191-	191-	181-	301-	126-	151-
DAILY RATE	10	10	10	10	10	10	10	10	10	10	10	10
PROD TARGET	199	239	199	179	219	199	199	249	199	189	249	189
DEMAND	5		282	335	355	415	390	440	380	490	375	340
PROJ INV	182	421	338	182	46							
CUM CHECK	176	415	338	182	46	170-	361-	552-	733-	1,034-	1,160-	1,311-

ITEM	SEDAN3	DESC	SEDAN AUTO (END ITEM)	ON HAND	6	SAFETY	0	HELD	0	BAL	6
IPP +/-											
DAILY RATE			3 6	5	7	7	5	7	9	5	6
PROD PLAN			66 100	115	140	145	130	140	170	115	110
NET DEMAND			66 100	115	140	145	130	140	170	115	110
ADJUSTMENTS											
HELD INV											

ITEM	SEDAN2	DESC	CM SEDAN AUTO (END ITEM)	ON HAND	8-	SAFETY	0	HELD	0	BAL	8-
IPP +/-											
DAILY RATE			5 6	5	7	6	5	7	7	5	5
PROD PLAN			8 95 110	105	140	110	135	130	135	120	100
NET DEMAND	8		95 110	105	140	110	135	130	135	120	100
ADJUSTMENTS	8-		8								
HELD INV	8-										

ITEM	SEDAN1	DESC	CM SEDAN AUTO (END ITEM)	ON HAND	10-	SAFETY	0	HELD	0	BAL	10-
IPP +/-											
DAILY RATE			6 7	6	7	7	7	6	10	6	7
PROD PLAN			10 120 125	135	135	135	175	110	185	140	130
NET DEMAND	15		115 125	135	135	135	175	110	185	140	130
ADJUSTMENTS	15-		10 5								
HELD INV	15-		5-								

This report shows the demand, inventory, and production levels for any twelve consecutive periods of a family operating plan and reflects the totals from the last aggregation. You can print this information for all families, a range of families, or only one family. You can optionally print the item production plans for each item in the families you selected, and the daily production quantities for families and items. You can also print the report in costs or units.

The report provides you with a worksheet copy of your family operating plans. As an option, it can also include demand, production, and inventory quantities for each item in the family.

Note: You can produce a printed copy of your family base plans if you print the Family Operating Plan Report before you replace family base plans with family operating plans.

The report is printed when you select option 9 on the Production Planning menu (AMLM10). A display appears for you to select what information you want included in the report.

The following fields make up the heading information for each production family on the report. The warehouse identifier also appears on the report. If the report for a family requires more than one page, this information is printed at the top of each new page.

Fields

UNITS/COSTS. The method in which the production quantities are printed. The word UNITS or the word COSTS is printed based on your selection on the Family Operating Plan Report Options display (AML261).

WAREHOUSE. The identifier of the planning warehouse.

FAMILY. The number of the production family whose family operating plan is printed below.

DESC (Description). The description of the production family whose family operating plan is printed below.

SIGNIFICANCE. Shows the number of zeros to use on the right of each quantity field to know what the full quantity is. If the field shows (), all quantities are printed in full. If the field shows (000), multiply all quantities by 1,000. If the field shows (000,000), multiply all quantities by 1,000,000. For example, if you see that the quantity significance for a family is (000), you know that a quantity that is printed as 2,795 is actually 2,795,000. This method of printing quantities makes them easier to read and adjusts very large quantities that exceed the length of the fields in which they are printed.

ON HAND. The total quantity of items in this family in inventory at the beginning of the first period in the family operating plan.

SAFETY (Safety stock). The sum of all item safety stock quantities in the family. They were added together during the last aggregation.

HELD. The total quantity of items in this family's inventory set aside for future planned shipments.

BALANCE. The inventory quantity for this family that is not assigned and is available for calculating the net demand. The production family balance equals family on-hand inventory, minus family safety stock, minus family held inventory.

RATE/DAY. The maximum or desired quantity of items in this family that can be produced in one working day. You entered this amount on the Display/Maintain Production Families display (AML361). This field is printed even if you typed N for PRINT DAILY RATES on the Family Operating Plan Report Options display (AML261).

PERIODS. Optional. The beginning dates of the production planning periods. You entered the first period you wanted printed on this report on the Family Operating Plan Report s display (AML261).

The following fields show the family's demand, inventory, and production levels you should maintain for each period.

BUILD +/- (Build more or build less). The amount the family's item trial plans must be adjusted (increased or decreased) to meet the production target for the family.

DAILY RATE. The total quantities of items in this family you need to produce daily to meet the family production target. This field is printed only if you typed Y for PRINT DAILY RATES on the Family Operating Plan Report Options display (AML261).

PROD TARGET (Production target). The total quantity of items in this family that management wants to produce in this period. This quantity is based on expected sales and the desired level of inventory.

DEMAND (Blended demand). The family forecast or customer orders, whichever is greater in a period. The family blended demand is the result of aggregating the blended demand of the items that make up this family.

PROJ INV (Projected inventory). The quantities of items in this family expected in inventory at the end of a period. The projected inventory for the first period is equal to the production family on-hand inventory plus the family production target, minus the family blended demand. For the following periods, projected inventory equals the projected inventory from the previous period, plus the family production target, minus the family blended demand.

Note: Projected inventory does not print for periods in which cumulative is negative.

CUM CHECK (Cumulative check). The result of the system checking to make sure that the cumulative production targets for a family are greater than or equal to the family's cumulative net demand. A negative amount in a period means that you need to increase production in or before that period to meet demand.

The following fields make up the heading information for each item in a family. This information and the item production plans that follow print only if you typed Y for **PRINT ITEM DETAIL** on the Family Operating Plan Report Options display (AML261).

Note: Item quantities appear in full. They are not affected by the quantity significance for the family.

ITEM. The number of the item whose item production plan is printed below.

DESC (Description). The description of the item whose item production plan is printed below. This description is taken from the Item Master file.

ON HAND. The total quantity of this item's on-hand inventory as of the first production planning period.

SAFETY (Safety stock). The total quantity of this item's on-hand inventory set aside for unplanned sales shipments.

HELD (Held inventory). The total quantity of this item's on-hand inventory set aside for future planned shipments. The held inventory you see below is a by-period amount.

BAL (Balance). The remaining quantity of this item in inventory. The item's balance equals the on-hand inventory, minus the safety stock, minus the held inventory.

The following fields show the item production plans by period for the items in a family.

IPP +/- (Item production plan build more or build less). The amount that the item's production quantities set in the trial plan vary from the item's production plan currently used in master scheduling.

DAILY RATE. The total quantity of this item you need to produce daily to meet the family production target. This field is printed only if you typed Y to **PRINT DAILY RATES** on AML261.

PROD PLAN (Production plan). The quantity of this item that should be produced by period. This is the current item production plan used for master scheduling.

NET DEMAND. The quantity of this item that should be produced according to the last aggregation. This amount is based on the item's blended demand minus its inventory balance.

ADJUSTMENTS. The changes made to an item's projected level of production in response to changes in demand. An item's production is increased or decreased with adjustments.

HELD INV (Held inventory). For each period, the quantity of this item in inventory set aside for future planned shipments.

Reference codes. General reference codes that indicate scheduling information about an item:

- CM** The item's Cumulative Material Lead Time (CMLT) falls within this period. This indicates that sometime within this period you could produce additional quantities without expediting even if materials are not currently on-hand.
- PS** Production for this item begins in this period. Production should not be scheduled before this period.
- PE** Production for this item ends in this period. Production should not be scheduled after this period.

Item Resource Report (AML321)

NORTHCREEK IND.	NO. 01	ITEM RESOURCE REPORT	DATE 8/04/**	TIME 10.08.23	PAGE 1	AML321
WAREHOUSE ATL						
FAMILY COMPACT-PF	DESCRIPTION	COMPACT AUTO PROD FAMILY				
ITEM NUMBER	-----RESOURCE-----	-----RESOURCE-----	-----RESOURCE-----	-----RESOURCE-----	-----RESOURCE-----	-----RESOURCE-----
	NUMBER VALUE	NUMBER VALUE	NUMBER VALUE	NUMBER VALUE	NUMBER VALUE	NUMBER VALUE
COMPACT1	00005 50,000	00006 10,900	00001 4,838	00003 3,300	00002 648	
COMPACT2	00005 48,000	00006 10,000	00001 4,837	00002 327		
COMPACT3	00005 50,000	00003 11,000	00001 6,037	00006 3,000	00002 1,331	
COMPACT4	00005 50,000	00002 176	00001 10			

NORTHCREEK IND.	NO. 01	ITEM RESOURCE REPORT	DATE 8/04/**	TIME 10.08.23	PAGE 2	AML321
FAMILY SEDAN-PF						
DESCRIPTION	SEDAN AUTO PROD FAMILY					
ITEM NUMBER	-----RESOURCE-----	-----RESOURCE-----	-----RESOURCE-----	-----RESOURCE-----	-----RESOURCE-----	-----RESOURCE-----
	NUMBER VALUE	NUMBER VALUE	NUMBER VALUE	NUMBER VALUE	NUMBER VALUE	NUMBER VALUE
SEDAN1	00005 60,000	00006 7,000	00001 4,838	00002 648		
SEDAN2	00005 70,000	00006 1,400	00002 568	00001 38		
SEDAN3	00005 60,000	00001 6,037	00002 1,331			

This report shows the five resources with highest values used by each master scheduled end item. The report is printed when you select option 5 on the Resource Profile Management menu (AMLM30).

If you selected a range of planning warehouses, a separate report is printed for each warehouse that falls within that range. The warehouse identifier appears on the report.

On this report the items not assigned to any production family are printed first, in item number sequence. Then items are printed by production family, beginning with the lowest-numbered production family.

For the list of items not in a production family, the words ITEMS NOT ASSIGNED TO A PRODUCTION FAMILY are printed in place of the family number and family description fields described below. If you typed Y on display AML310 to bypass items already assigned to production families, only these unassigned items are printed on the report. If you typed in N, the report also contains, by family, the items now in production families.

Note: To be included on this report, an item must be an end item and must have a resource profile.

Fields

WAREHOUSE. The identifier of the planning warehouse.

FAMILY. The number of the production family whose member items appear on the list below. This field does not appear when the report contains items not assigned to a family.

DESCRIPTION. A description of the production family. This field does not appear when the report contains items not assigned to a family.

ITEM NUMBER. The number of a master scheduled end item assigned to the production family identified above.

RESOURCE NUMBER. The unique identifying number of a critical resource that this item uses. The report lists up to five resources for each item. The resources print in descending order based on the total value of each resource needed for that item.

RESOURCE VALUE. The cost of the total quantity of this resource needed to produce one standard lot or batch of the item. The system totals the quantity from the item's resource profile and multiplies it by the cost of the resource. For more information about this calculation, see "Calculating resource values" on page 2-98.

Master Schedule Open Order Maintenance List (AML455)

NORTHCREEK IND.		NO. 01		MASTER SCHEDULE OPEN ORDER MAINTENANCE LIST			DATE	8/04/**	TIME	17:15:06	PAGE	1	AML455
USER ID TRONIE													
W/H	ORDER NUMBER	ITEM	ACTION	START DATE	DUE DATE	ORDER QUANTITY	COMMENTS						
ATL	M053220	COMPACT1	CHANGE										
		ORIGINAL VALUES	-	7/17/**	8/06/**	40.000							
		CHANGED TO	-	7/17/**	8/06/**	50.000							
MPA	M052990	COMPACT1	CANCEL										
		ORIGINAL VALUES	-	8/04/**	7/29/**	30.000							
		CHANGED TO	-	8/04/**	7/29/**	.000							

Note: If Repetitive Production Management (REP) is installed and interfacing with MRP and the item is schedule controlled, ORDER is changed to SCHED/ORDER in the name of the report.

This list shows any changes you made to open orders while reviewing and updating master production schedules on the Display/Maintain Master Schedule displays, AML452 and AML453. The list is printed automatically at the end of a master schedule maintenance session (option 2, Display/Maintain Master Schedule, on menu AMLM20) if you made any changes to open orders. The identifier of the planning warehouse you selected also appears on the report.

This list is printed to help you change your open orders through another application, such as Inventory Management or Purchasing if installed, so you can complete the changes you made in MPSP. Any changes you make to open orders in MPSP remain incomplete (pending) until you change the orders directly.

When you change the quantity or due date of an open order, the order receives an exception code of P (pending); that exception code remains until you change the order itself using another application. The system uses the MPSP pending changes when planning orders; but if other exception conditions apply to those orders, the system cannot show you the other exception codes until you remove the Pending condition and replan.

Note: The changes you make during MPSP master production schedule maintenance do not appear in MRP until you change the open orders using another application and perform a new MRP planning run.

The list shows the previous (Original) version and the changed version of each open order you maintained. The list also provides space on each page for any comments or reminders you want to write.

Fields

W/H (Warehouse). The identifier of the planning warehouse.

ORDER, REQUISITION, or ORD/SCH NUMBER. The number of the open order or requisition you changed. If REP is installed and interfacing with MRP and the item is schedule controlled, the field is titled ORD/SCH NUMBER and the REP schedule number is printed.

ITEM . The number of the master scheduled item in the order or requisition you changed.

ACTION. The kind of change you made (change or cancel). You cannot add or firm an open order through master production schedule maintenance.

START DATE. The date when work began on this order or when work is scheduled to begin. If you did not specify a start date and work on the order had not started, the system calculated the date using the item's lead time and due date. For requisition this is the start date of requisitions.

Note: If you have specified a standard lot size (LOTSZ) and a variable lead time (LTVAR) for this item, the system may calculate the start date using the quantity-based lead time defined in MRP.

DUE DATE. The date when this order or requisition must be completed.

ORDER, ORD/SCH, or REQUISITION QUANTITY. The quantity of this item needed in inventory by the due date. If REP is installed and interfacing with MRP and the item is schedule controlled, the field is titled ORD/SCH QUANTITY.

COMMENTS. A space you can use for comments or notes.

Master Schedule Planning Report (AML471)

NORTHCREEK IND.		NO. 01	MASTER SCHEDULE PLANNING REPORT				DATE 8/04/**	TIME 17.17.13	PAGE 5	AML471
WAREHOUSE ATL	FAMILY SEDAN-PF	PLANNER 1	EXCEPTIONS ONLY	START DATE 7/28/**	CURRENT DATE 8/18/**	CUTOFF DATE 8/17/**				
ITEM SEDAN3	DESC SEDAN AUTO (END ITEM)									
ON HAND 6.000	ALLOC .000	AVAIL 6.000	ON ORDER 720.000	SMOOTH DATE 6/01/**	SMOOTH CODE 3					
--- ITEM CODES ---										
TYPE MAXLN A	MIN .000	TYPE M	UNIT 6,000.0000	LOC *****	SAFETY .000					
ORDPOL G	MAX 30.000	PUR 0.0	SETUP .050	CLASS ****	WEIGHT .000					
LOT 10.000	MULT 20.000	MFG 17.0	PRICE / **	PUR UM **	CARRY .000					
SBQ 1.000	FOQ .000	VAR 0.0	UNIT 7,000.000	STK UM **	SHRINKAGE .000					
SOURCE PROD PLAN	PER OF SUP 3	CMLT 30.0		PLN LVL **	ENG/DRAW *****					

PERIOD BALANCES - ISSUES	.000	RECEIPTS .000	ADJUSTMENTS .000	PRODUCTION RCVD .000						

DUE DATE	ORDER	STATUS	ORD QTY	START DATE	PROD PLAN	REF	BLENDED DMD	EXPECTED INV	EXCEPTION CONDITIONS	
7/29/**	M052970	10	10.000	8/02/**						
7/29/**	M053210	10	40.000	7/15/**						
8/04/**					.000	PLAN				
8/06/**	M053030	10	35.000	7/26/**				91.000		
8/06/**	M053090	10	15.000	8/01/**				106.000		
8/06/**	M053150	10	20.000	7/26/**	120.000	VAR		126.000	VARIANCE EXCEEDS LIMITS	
9/01/**					.000	PLAN				
9/20/**	M053280	10	100.000	8/23/**	100.000	VAR		226.000	VARIANCE EXCEEDS LIMITS	

9/30/**					CMLT TF					
10/06/**					119,934.000	PLAN	35.000	191.000		
10/13/**							15.000	176.000		

10/14/**					DEMAND TF					
10/20/**							60.000	116.000		
10/22/**	M053290	10	20.000	9/27/**				136.000		
11/01/**	M053300	10	20.000	10/09/**	119,894.000-	VAR		156.000	VARIANCE EXCEEDS LIMITS	
11/03/**					100,000.000	PLAN	100.000	56.000		
11/05/**	M053310	10	100.000	10/11/**	99,900.000-	VAR		156.000	VARIANCE EXCEEDS LIMITS	
12/01/**					115,000.000	PLAN				
12/01/**	PLANNED	M	120.000	11/04/**	114,880.000-	VAR	115.000	161.000	VARIANCE EXCEEDS LIMITS	
1/05/**					140,000.000	PLAN				
1/05/**	PLANNED	M	140.000	12/08/**	139,860.000-	VAR	140.000	161.000	VARIANCE EXCEEDS LIMITS	
2/02/**					145,000.000	PLAN				
2/02/**	PLANNED	M	140.000	1/08/**	144,860.000-	VAR	145.000	156.000	VARIANCE EXCEEDS LIMITS	
3/02/**					130,000.000	PLAN				
3/02/**	PLANNED	M	140.000	2/05/**	129,860.000-	VAR	130.000	166.000	VARIANCE EXCEEDS LIMITS	
4/06/**					140,000.000	PLAN				
4/06/**	PLANNED	M	140.000	3/12/**	139,860.000-	VAR	140.000	166.000	VARIANCE EXCEEDS LIMITS	
5/04/**					170,000.000	PLAN				
5/04/**	PLANNED	M	160.000	4/09/**	169,840.000-	VAR	170.000	156.000	VARIANCE EXCEEDS LIMITS	
6/01/**					115,000.000	PLAN				
6/01/**	PLANNED	M	120.000	5/06/**	114,880.000-	VAR	115.000	161.000	VARIANCE EXCEEDS LIMITS	
7/06/**					110,000.000	PLAN				
7/06/**	PLANNED	M	120.000	6/10/**	109,880.000-	VAR	110.000	171.000	VARIANCE EXCEEDS LIMITS	
8/03/**					120,000.000	PLAN				
8/03/**	PLANNED	M	120.000	7/09/**	119,880.000-	VAR	120.000	171.000	VARIANCE EXCEEDS LIMITS	

This report provides a printed record of the master production schedule for one or more master scheduled items. It includes all open and planned orders for the item, current demand, calculated future inventory levels, and exception messages to identify conditions requiring the planner's attention. The system gets current information for the report at the time of printing.

The report is printed when you select option 5 on the Master Schedule Planning menu (AMLM20).

If you selected a range of planning warehouses, a separate report is printed for each warehouse that falls within that range. The warehouse identifier appears on the report.

Fields

WAREHOUSE. The identifier of the planning warehouse.

Sequence selected. The sequence of items you selected for the report on AML460.

- FAMILY and the family number appear if you chose to print the report by production family. The report prints schedules for end items assigned to one or a range of production families. The number shown identifies the family of the item whose schedule is on that page.
- REPORT BY PLANNER appears if you chose to print the report by planner. The report is printed schedules for items assigned to one or a range of planners.

PLANNER. The number of the planner for the item whose schedule is on the page.

Items included. The type of item you selected on AML460 for inclusion in the report.

ALL ITEMS SHOWN: The report is printed with schedules for all items within the sequence and range you specified.

EXCEPTIONS ONLY: The report contains the schedules with exception conditions, within the sequence and range you specified.

START DATE. The first day of the master production schedule horizon. The system calculates this date by subtracting the number of overdue days (OVDP) set in Material Requirements Planning from the master schedule current date used in the last planning run.

CURRENT DATE (MPS Current Date). The date that defines the current period in the master scheduling horizon. The MRP Current Date for the next MRP planning run in which you use new master scheduled orders should be the same as this date.

CUTOFF DATE. The last day of the master production schedule horizon. The system does not plan periods after this date.

ITEM. The number of the master scheduled item whose schedule is on this page.

DESC (Description). A brief description of the master scheduled item.

ON HAND. The quantity of this item now in inventory.

ALLOC (Current Allocations). The amount of this item committed or assigned to released manufacturing orders within the item's lead time or the allocation date (ALDT), whichever is less. Current allocations are total manufacturing allocations (MALQT) minus future allocations at the time the report is printed.

Note: Future allocations are inventory amounts assigned for use after the item's lead time date (current date plus the item's lead time) or after the current allocation period for the item, whichever is less. The system calculates the current allocation period by adding the allocation days (ALDP) to the current date.

If the item is an end item, this field is zero.

AVAIL (Available Inventory). The amount of this item not committed to other uses. Available inventory is the on-hand inventory minus current allocations.

Note: This calculation does not include an adjustment for activity in the period (as MRP does) because the system gets current information at the time of printing.

ON ORDER. The sum of the open manufacturing and purchase orders for this item.

The following fields appear if Repetitive Production Management (REP) is installed and interfacing with MRP and the item is schedule controlled:

SMOOTH DATE. A specific date you want smoothing to begin. It is used as an override to the smoothing code. This date is used if it is greater than the system date.

SMOOTH CODE. The code specifies if and how smoothing is applied to an item in production. The field can be overridden by the smoothing start date.

Item Codes.

TYPE (Item type code): A code that identifies the item type for this master scheduled item:

- | | |
|----------|-------------------------|
| 1 | Assembly or subassembly |
| 2 | Fabricated item |
| 3 | Raw material |
| 4 | Purchased item |
| 9 | User option |

MAXLN (Maximum lines): The maximum number of report pages to be printed for this item:

- | | |
|--------------|-----------|
| A | All pages |
| blank | One page |

ORDPOL (Order policy code): A code that identifies the guidelines for ordering this item:

- | | |
|----------|---------------------------------------|
| A | Discrete order quantity |
| B | Order point, order quantity |
| C | Order point, order up to level |
| D | Fixed quantity |
| F | Part period balancing (standard cost) |
| G | Time periods of supply |
| H | Discrete above a minimum quantity |
| I | Part period balancing (current cost) |
| Z | User option |

For a production planned item, the order policy code is always G. Order policy codes B and C should not appear for master scheduled items.

LOT (Standard lot size): The amount of this item that is produced in one manufacturing run. This figure is used in Product Data Management for product costing.

Standard lot size is also used to calculate variable lead times based on the quantity of the order. The system calculates a lead time for each planned order if:

- A variable lead time (LTVAR) for the item exists in the Item Balance file.
- A lot size (LOTSZ) for the item exists in the Item Master file (ITEMASB).
- The planned order quantity differs from the standard lot size.

SBQ (Standard batch quantity): The amount of this item that is used to calculate the required quantities for components. The quantity can represent the normal output or a production goal. It can also serve as a multiplier to reduce the level of precision required for components that are used in very small quantities relative to one unit of the end item.

Standard batch quantity can provide the basis for a bill of material for an item with a quantity other than one. For example, if a parent item is produced in batches of five gallons, the quantity requirements for components (quantity per) are based on producing five gallons of the parent instead of one gallon.

SOURCE (Source of demand): The type of demand used for generating this master production schedule. The types are:

BLENDED	Blended demand
CUST ONLY	Customer/Expected customer orders only
FCST ONLY	Forecasts only
MANUAL	Manually entered firm planned orders only
PROD PLAN	Item production plan

Note: The following four quantity fields describe the guidelines used by the system in planning orders for master production schedules. These quantities also guide you in entering manual orders or maintaining orders.

Lotsize.

MIN (Minimum quantity): The minimum amount of this item to specify in an order.

MAX (Maximum quantity): The maximum amount of this item to specify in an order.

MULT (Multiple quantity): A factor for rounding off order amounts. You should plan orders for this item in multiples of the quantity shown.

FOQ (Fixed order quantity): The set amount of this item that you should specify in an order. Order policy codes D and H use a fixed order quantity.

PER OF SUP (Period of supply): The number of days of demand that an order should cover.

For a production planned item, this field shows a numeric code indicating how often within each planning period the system schedules orders for the item. The codes are:

- 1 One time per week
- 2 Two times per period
- 3 One time per period
- 4 One time per work day

Leadtime.

TYPE (Lead time code): Indicates whether the system uses manufacturing or purchasing lead times and adjustments in planning orders for this item.

- M Manufacturing lead times
- P Purchasing lead times

PUR (Purchasing lead time): The vendor's quoted lead time (in work days) for supplying this item (LTPUR) plus the purchasing lead time adjustment (LTADP).

MFG (Manufacturing lead time): The minimum amount of time (in work days) required to manufacture this item from the next lower level of components (LTMAN) plus the manufacturing lead time adjustment (LTADM).

VAR (Variable manufacturing lead time): The portion of total manufacturing lead time that is dependent on the quantity produced.

CMLT (Cumulative material lead time): The longest length of time required to produce this item if materials are not available in the plant when the order is released. This amount includes purchase and manufacturing lead times.

Cost.

UNIT (Unit cost): The cost of one stocking unit of this item, based on either standard costs or current costs.

This field shows current cost if the order policy code is I (part-period balancing, current cost). If the order policy code is I, the system uses the first cost value it can retrieve from the sequence of fields listed here:

SEQ	TYPE	COST USED	FILE USED
1	current	Current unit cost (CURUC)	Item Master
2	current	Last unit cost (LCOST)	Item Balance
3	standard	Unit cost default (UCDEF)	Item Master

If the order policy is not I, this field shows standard cost. The system uses the first cost value it can retrieve from the sequence of fields listed below:

SEQ	TYPE	COST USED	FILE USED
1	standard	Standard unit cost (STDUC)	Item Master
2	standard	Standard unit cost (STDUC)	Item Balance
3	standard	Unit cost default (UCDEF)	Item Master

SETUP (Setup cost): The setup cost for manufacturing this item. The field shows current cost only when the order policy code for this item is I (part-period balancing, current cost) or when the code is F (part-period balancing, standard cost) and the standard setup cost (STDSU) is not available.

PRICE (Base unit price): A user-entered price for one stocking unit of the item. The price appears on the next line. If pricing is based on a unit other than the stocking unit, an abbreviation for the pricing unit appears to the right of PRICE. If the price is based on the stocking unit, the word UNIT appears instead on the next line with the price.

Item Characteristics.

LOC (Warehouse stock location): The location of this item in the MRP planning warehouse.

CLASS (Item class): A user-entered code that groups this item with others that are like it in some way. Some functions in PDM/EPDM and Inventory Management (IM) allow the user to include items by class.

PUR UM (Purchase unit of measure): Identifies the unit of measure used for purchasing this item.

STK UM (Stocking unit of measure): The unit of measure used for stocking and releasing this item in inventory.

PLN LVL (Planning level): The number of the product structure level at which this item was planned. For a master schedule component item, this number shows the lowest level at which the item is used.

SAFETY (Safety stock): A set quantity of this item that you reserve as protection against unexpected increases in demand within the item's lead time.

WEIGHT (Unit weight): The weight of one unit of this item (WEGHT).

CARRY (Carrying rate): Used to calculate the cost of carrying this item in inventory. The rate is expressed as a percentage of the item's total annual cost or value. If the value for CARRY in the Item Master file is zero, the system uses the company carrying rate (carrying cost percent factor) entered from the Inventory Management Questionnaire.

SHRINKAGE (Shrinkage factor): The percentage of an order for this item that normally is lost or cannot be used. The system uses this factor to increase order sizes to compensate for the unusable amounts.

ENG/DRAW (Engineering drawing number): A unique, user-entered number that identifies the engineering drawing of this item.

Period Balances.

ISSUE (Issues this period): The amount of this item issued without charge for internal use since the last period closing, and the unused quantity returned to inventory. If this quantity is negative, inventory received more material as returns than it issued for use.

RECEIPTS (Receipts this period): The amount of this item received into inventory since the last period closing.

ADJUSTMENTS (Adjustments this period): The sum of all adjustments to inventory for this item since the last period closing.

PRODUCTION RCVD (Production received): The quantity of the item received during the current period (the period that includes the system date). This field is printed only for a production planned item. The system adds this quantity to the sum of all orders in the first production planning period shown and compares the total to the item production plan for the period to calculate the variance.

The following lines make up the body of the report. Information appears in chronological order by period, and time fences appear if you completed the related fields in the Item Master and Item Balance files.

The specific content of each line varies, depending on the kind of information printed. That is, information may not appear in all of the fields on a line.

The planned orders and any generated demand (GE) shown for the item are the result of the most recent planning run and any master production schedule maintenance since the run. Other information shown, including demand and projected inventory, is current as of the time the report is printed.

DUE DATE. The due date for the information printed on each line.

- If the line shows an order, this date is the due date for the order.
- If the line shows generated demand, this date is the date when the item is needed.
- If the line shows a safety stock requirement, this date is the earliest date that an order released in the current period can replenish safety stock. The system calculates this date by adding the item's lead time to the master production schedule current date.
- If the line shows blended demand, this date is the beginning date of the period in which the demand occurs.
- If the line shows demand from an item production plan or forecasts, this date is the beginning date of the period in which the demand occurs.
- If the line shows a time fence, this date is the date of that time fence.

ORDER, SCH/ORD, or REQUISITION. The order number for any open order or requisition. The following words can appear:

M-FIRM	Firm planned manufacturing order
P-FIRM	Firm planned purchase order
M-PLAN	Planned manufacturing order
P-PLAN	Planned purchase order
S-PLAN	Planned schedule

Note: If Repetitive Production Management (REP) is installed and interfacing with MRP and the item is schedule controlled, ORDER is changed to SCH/ORD and the REP schedule is printed.

STATUS (Planning status). Three fields that describe the current status of an order and how it relates to the master production schedule.

First status field: blanket orders: This field shows a B if the order is a blanket purchase order. The field shows R if the order is blanket purchase order release.

Second status field: order status: This field shows the order status code for any released manufacturing or purchase order. The field is blank if the order is firm planned or planned.

The order status codes that can appear for a manufacturing order are:

- 10** Order released, no activity reported
- 40** Order started—material, outside operations, labor, machine, or miscellaneous charges transaction processed
- 50** Production Control and Costing (outside operations, labor, machine, and miscellaneous charges) complete; Inventory Management receipt to stock not reported complete

The order status codes that can appear for a purchase order (including a blanket purchase order release) are:

- 10** Purchase order released
- 20** Purchase receipt to dock
- 30** Purchase receipt to inspection
- 40** Purchase receipt to stock

Third status field: exception codes: The code in this field identifies a special condition requiring the planner's attention. The report explains each code with a printed message on the right side of the report. The exception codes are:

- C** Cancel order (firm planned order, open order, or requisition)
- D** Defer order (firm planned order, open order, or requisition)
- E** Expedite order (firm planned order, open order, or requisition)
- F** Planned order inside CMLT (planned orders only)
- H** Order date past cutoff (firm planned order, open order, or requisition)
- L** Order start date low (firm planned order, open order, or requisition) or Order due date low (firm planned order, open order, or requisition)
- M** Maximum order quantity exceeded (planned orders only)
- P** Pending change (open order or requisition)
- R** Reschedule order or requisition (firm planned order, open order, or requisition)
- X** Exception order (planned orders only)

For more information about exception codes and related conditions, see Chapter 2 "Managing Master Production Schedule Planning".

ORD QTY (Order quantity) or QUANTITY. The quantity of the order (open, firm planned, or planned) identified in the ORDER field of the line.

Note: If Repetitive Production Management (REP) is installed and interfacing with MRP and the item is schedule controlled, ORD QTY is changed to QUANTITY.

START DATE. The date when work on this item must begin to complete it by the due date shown. This date is:

- The date when work started on an open order or requisition
- The start date you entered during master production schedule maintenance, if you entered a date
- A calculated start date based on the item's lead time, if you did not enter a start date for the item.

Note: If you specified a standard lot size (LOTSZ) and a variable lead time (LTVAR) for this item, the system may calculate the start date using the quantity-based lead time defined in MRP.

Demand. This field shows quantities of planned or generated demand. If the item is an end item that is production planned, the heading is PROD PLAN. If the item is an end item using another source of demand or is a component item, the heading is DEP DMD.

PROD PLAN (Item Production Plan): The production goal for this item for this period. This field can show other quantities. The REF (Reference) field to the right identifies the quantity you see. This field heading appears only for a production planned item. For a non-production planned item, DEP DMD (dependent demand) heading appears.

DEP DMD (Dependent demand): The dependent demand generated for this item for this period. The field shows specific kinds of dependent demand. The REF (Reference) field to the right identifies each kind. This heading appears only for a non-production planned item (end item or component item). For a production planned item, the PROD PLAN heading appears.

REF (Reference). Describes the quantities shown in the PROD PLAN or DEP DMD field. The reference abbreviations that describe the PROD PLAN field are:

PLAN Item production plan

VAR Difference (variance) between the item production plan and the planned receipts (receipts plus orders) for the period

SHRK Shrinkage requirements for the item

The reference abbreviations that describe the DEP DMD column are:

ALOC Future allocations of the item

OBKL Option backlog from customer orders for an option in a model line

OPFC Forecasts for an option in a model line

GEN Generated demand caused by higher level items

SFTY A safety stock requirement for the item

SHRK A shrinkage quantity expected for this order

BLENDDED DMD (Blended demand). The greater of forecasted demand or customer/expected customer orders for this period. The system calculates blended demand if the item's MPS planning source code in the Item Master file is anything other than C (customer orders only).

If the MPS planning source code is C (customer orders only), total customer/expected customer orders for each period appear. If customer backlog exists before the date of the report, the orders are listed and totalled by day to reflect the distribution of the backlog.

If you use the Demand Interface file for loading forecasts or customer backlog, or if you use the Customer Order Management application, information can appear in the BLENDED DEMAND field regardless of the planning source for the item. If demand for the item comes from an item production plan, the **BLENDDED DEMAND** field allows you to compare planned production to forecasts or customer orders. The information may help you to adjust your item production plans.

EXPECTED INV (Expected inventory). A running total of the inventory level for this item by period. Starting with the available amount (AVAIL), the inventory is increased by item orders and decreased by the blended demand for each period. For component items, the inventory is decreased by generated demand, allocations, option backlog, and unconsumed option forecasts if positive.

Expected inventory should always be positive. If it becomes negative, the message PROJECTED SHORTAGE is printed in the **EXCEPTION CONDITIONS** field.

EXCEPTION CONDITIONS. Brief messages identifying schedule problems that require the planner's attention. Exception messages explain symbols in the third **STATUS** field.

Only one message can appear per line, even if more than one exception condition exists for the information on that line. For example, if a PROJECTED SHORTAGE condition exists and an EXPEDITE TO **/**/** message also exists, the PROJECTED SHORTAGE message does not appear.

The exception messages that can appear are:

CANCEL ORDER
DEFER TO **/**/**
EXCEPTION ORDER
EXPEDITE TO **/**/**
MAX ORDER QTY EXCEEDED
ORDER DATE PAST CUTOFF
ORDER DUE DATE LOW
ORDER START DATE LOW
PENDING CHANGE
PLANNED ORDER INSIDE CMLT
PROJECTED SHORTAGE
RESCHEDULE TO **/**/**
VARIANCE EXCEEDS LIMIT

The DEFER, RESCHEDULE, and EXPEDITE messages include the new recommended date to help you make the appropriate change. These exception messages and the related schedule conditions are explained in Section 3.

CMLT TF (Cumulative Material Lead Time, Time Fence). The end of the firm period of the master production schedule. The CMLT Time Fence identifies the total lead time required to produce this item, including time to purchase materials and parts. Production changes between the Demand Time Fence and the CMLT Time Fence should be made only after you consider the impact on production schedules, such as whether components are available to support an increase.

This time fence does not appear if the CMLT (CMTLT) field is zero in the Item Balance file record for this item. If the CMLT is equal to the days specified for the Demand Time Fence, a combined DMD/CMLT Time Fence is printed.

DEMAND TF (Demand Time Fence). Marks the end of the frozen period of the master production schedule. Any changes to the production schedule before the Demand Time Fence can affect production schedules seriously and should be resisted. This time fence can mark the limit of the final assembly lead time (FALT) for this item.

If a Demand Time Fence appears, blended demand for this item does not include forecasts until the periods after the time fence. The Demand Time Fence is not printed on the report if the **DEMAND TIME FENCE (DTFD)** field is zero in the Item Plan file record for this item.

Planning Run Status Report (AML480)

```

NORTHCREEK IND. NO. 01          PLANNING RUN STATUS REPORT          DATE 8/04/** TIME 17.51.45 PAGE 1 AML480
WAREHOUSE ATL

----- HORIZON -----          ----- EXTRACTION -----          ----- PLANNING RUN -----
MPS START DATE      7/28/**          EXTRACT OPTION              NO          PLAN TO LEVEL REQUESTED    00
MPS ALLOCATION DATE  8/26/**          LOWEST LEVEL EXTRACTED      04          INITIAL PLANNING LEVEL     00
MPS CURRENT DATE    8/18/**          LAST EXTRACTION DATE        8/18/**     LOWEST LEVEL PLANNED       00
MPS CUTOFF DATE     8/17/**          DEMAND FILE DATE            8/04/**     PROD PLAN FILE DATE        8/04/**

                                NO ERRORS DETECTED
  
```

This report shows reference information about a master production schedule generation (planning run) and lists any processing file errors that occurred. The report is printed at the end of each master production schedule generation (option 1, Generate Master Schedules, on menu AMLM20).

If you selected a range of planning warehouses, a separate report is printed for each warehouse that falls within that range. The warehouse identifier appears on the report.

This report contains reference information first, showing the dates, conditions, and options that applied to this run. If any errors occurred, the report lists them next, with file and record information where it is needed. The reference information is printed under three headings: HORIZON, EXTRACTION, and PLANNING RUN.

Fields

WAREHOUSE. The identifier of the planning warehouse.

MPS (Master Production Schedule) START DATE. The first day of the master scheduling horizon. This date is backdated from the MPS CURRENT DATE using the number of overdue work days (OVDP) set in MRP.

MPS ALLOCATION DATE (ALDT). After this date or the item's lead time, whichever is nearer, allocations of master scheduled component items become future allocations. The system calculates this date by adding the number of allocation days set in MRP (ALDP) to the MPS CURRENT DATE (MPCUR).

MPS CURRENT DATE. The date that identifies the current period in the master scheduling horizon. Safety stock requirements and inventory projections are shown starting from this period. Demand or inventory receipts due before this period are overdue. The system uses this date to calculate the horizon cutoff date.

MPS CUTOFF DATE. The last day in the master scheduling horizon. No orders are planned for periods after this date.

The following fields identify the demand information that the system gathered or used for this planning run.

EXTRACT OPTION. The option (Y or N) that controlled whether the system gathered current forecast and customer demand information to plan orders for this run, or used information gathered previously. You set this option when you typed Y or N for **EXTRACT <Y/N>** on the Generate Master Schedules Planning Run Options display (AML410).

LOWEST LEVEL EXTRACTED. The number of the lowest product structure level for which the system gathered forecast and customer demand information. If the extraction was interrupted and no information was extracted for any level, the field shows NONE.

LAST EXTRACTION DATE. The date when you last gathered forecast and customer demand information to use for generating master production schedules. If demand has changed significantly since this date, you should start the planning run again and extract current information.

DEMAND FILE DATE. The date of the first period in the Demand Interface file that contains forecasts or user-entered customer orders.

The following fields describe the limits the system used in planning orders during this master production schedule generation.

PLAN TO LEVEL REQUESTED. The lowest product structure level of master scheduled items that you included in this planning run. You entered this number in the **PLAN ORDERS TO THIS LEVEL** field on the Generate Master Schedules Planning Run Options display (AML410).

INITIAL PLANNING LEVEL. The highest product structure level of master scheduled items for which the system planned orders in this planning run. This number appeared in the **PLANNING WILL BEGIN AT LEVEL** field on the Generate Master Schedules Planning Run Status display (AML411).

LOWEST LEVEL PLANNED. The number of the lowest product structure level for which the system planned orders in this planning run. This number is usually the same as **PLAN TO LEVEL REQUESTED**. If the planning run was interrupted and no orders were planned, the field shows NONE.

PROD (Production) PLAN FILE DATE. The beginning date of the earliest period in the Item Production Plan file. You set this date each time you replace all item production plans.

ERRORS DETECTED. A title identifying the part of the report where error messages are printed. If the system found no errors during this planning run, NO ERRORS DETECTED is printed.

Replace Family Base Plans Error List (AML221)

```

NORTHCREEK IND.  NO. 01          REPLACE FAMILY BASE PLANS ERROR LIST    DATE  8/04/**  TIME 14.57.26  PAGE   1  AML221
WAREHOUSE  ATL
FAMILY SELECTED ALL FAMILIES

FAMILY          MESSAGE
COMPACT-PF      W AM-8536 NET DEMAND EXCEEDS PRODUCTION TARGETS
SEDAN-PF        W AM-8536 NET DEMAND EXCEEDS PRODUCTION TARGETS
  
```

```

BASE PLANS REPLACED    2
  
```

This report identifies errors that occur when you choose option 6, Replace Family Base Plans, on the Production Planning menu (AMLM10) to replace family base plans with family operating plans for one or all production families.

If you selected a range of planning warehouses, a separate report is printed for each warehouse that falls within that range. The warehouse identifier appears on the report.

This report is printed automatically when you replace family base plans. Use it to review family or file errors you may need to correct.

Fields

WAREHOUSE. The identifier of the planning warehouse.

FAMILY SELECTED. The number of the production family if you replaced the family base plans for only one family. The phrase ALL FAMILIES is printed if you replaced the family base plans with family operating plans for all production families.

FAMILY. The number of each production family in which the system found a processing error during replacement.

MESSAGE. Message number and text describing the error condition that occurred.

FILE. The name of the file from which the system was attempting to retrieve information when the error occurred. This field appears only if the error requires the additional information.

NO ERRORS WERE FOUND. Indicates that no errors occurred during replacement; appears only if no error messages are printed on the report.

BASE PLANS REPLACED. The number of family base plans replaced with family operating plans.

Replace Item Production Plans Error List (AML250)

NORTHCREEK IND. NO. 01 REPLACE ITEM PRODUCTION PLANS ERROR LIST DATE 8/04/** TIME 15.52.44 PAGE 1 AML250

WAREHOUSE ATL

FAMILY SELECTED ALL FAMILIES

FAMILY NO.	ITEM NO.	MESSAGES
COMPACT-PF	COMPACT2	W AM-8554 ITEM HELD INVENTORY IS NEGATIVE
COMPACT-PF	COMPACT3	W AM-8554 ITEM HELD INVENTORY IS NEGATIVE
COMPACT-PF	COMPACT1	W AM-8554 ITEM HELD INVENTORY IS NEGATIVE
COMPACT-PF	COMPACT4	W AM-8554 ITEM HELD INVENTORY IS NEGATIVE
SEDAN-PF	SEDAN3	W AM-8554 ITEM HELD INVENTORY IS NEGATIVE
SEDAN-PF	SEDAN2	W AM-8554 ITEM HELD INVENTORY IS NEGATIVE
SEDAN-PF	SEDAN1	W AM-8554 ITEM HELD INVENTORY IS NEGATIVE

FAMILY PLANS REPLACED

ITEM PLANS REPLACED

This report identifies errors that occur when you choose option 7, Replace Item Production Plans, on the Production Planning menu (AMLM10) to replace item production plans with item trial plans for one or all production families.

If you selected a range of planning warehouses, a separate report is printed for each warehouse that falls within that range. The warehouse identifier appears on the report.

This report is printed automatically when you replace item production plans. Use it to review family, item, or file errors you may need to correct.

Fields

WAREHOUSE. The identifier of the planning warehouse.

FAMILY SELECTED. The number of the production family if you replaced the item production plans for only one family. The phrase ALL FAMILIES is printed if you replaced item production plans with item trial plans for all production families.

FAMILY NO. The number of each production family in which the system found an error during replacement.

ITEM NO. The number of the item the system found in error during replacement.

MESSAGES. Message number and text describing the error condition that occurred.

NO ERRORS WERE FOUND. Indicates that no errors occurred during replacement; appears only if no error messages are printed on the report.

FAMILY PLANS REPLACED. The number of families whose item production plans were replaced with item trial plans.

ITEM PLANS REPLACED. The total number of item production plans replaced with item trial plans for the families selected.

Resource Master File List (AML581)

NORTHCREEK IND. WAREHOUSE ATL	NO. 01	RESOURCE MASTER FILE LIST	DATE 8/04/**	TIME 10:09:30	PAGE 1	AML581
----------------------------------	--------	---------------------------	--------------	---------------	--------	--------

RESOURCE NUMBER	DESCRIPTION	UNIT OF MEASURE	RESOURCE PER DAY
CARB	FOUR BARRELL CARBURETOR	EA	450
LABOR	WORK CENTER #1	HRS	15
MACH1	MILLING MACHINE #2 TIME	HRS	16
00001	MACHINE HOURS	HRS	122
00002	LABOR HOURS	HRS	45
00003	PURCHASING UNIT COST	DLR	121
00004	MANUFACTURING UNIT COST	EA	75
00005	UNITS OF MANUFACTURE	EA	55
00006	UNITS OF PROCUREMENT	EA	130

9 RESOURCES LISTED

This report shows all of the critical resources you described and assigned a unique number to using Resource Master file maintenance. The report is printed when you select option 2, Resource Master File List, on the Resource Profile Management menu (AMLM30).

If you selected a range of planning warehouses, a separate report is printed for each warehouse that falls within that range. The warehouse identifier appears on the report.

Use this report to review all of the critical resources in the Resource Master file. With this report, you can:

- Verify the resources you have described
- Find the number of a specific resource
- Identify unassigned resource numbers that are available when you describe other critical resources.

Fields

WAREHOUSE. The identifier of the planning warehouse.

RESOURCE NUMBER. The unique identifying number you assigned to this resource.

DESCRIPTION. A description that helps to identify this resource.

UNIT OF MEASURE. The code for the unit used in measuring this resource. Your company establishes this code.

RESOURCE PER DAY. The quantity of this resource available for use in one work day. The quantity may reflect average use, a maximum rate of replenishment, or a maximum capacity.

RESOURCES LISTED. Number of resources listed. The total number of resources listed on this report.

Resource Master File Maintenance Edit List (AML599)

NORTHCREEK IND.	NO. 01	RESOURCE MASTER FILE MAINTENANCE EDIT LIST	DATE 8/04/**	TIME 15:41:19	PAGE 1	AML599
				USER ID TRONIE		
	WAREHOUSE	RESOURCE NUMBER	DESCRIPTION	UNIT OF MEASURE	RESOURCE	PER DAY
RECORD ADDED	ATL	CARB	FOUR BARREL CARBURETOR	EA		150
CHANGE - OLD VALUE	ATL	00001	MACHINE HOURS	HRS		123-
CHANGE - NEW VALUE	ATL	00001	MACHINE HOURS	HRS		125
RECORD DELETED	ATL	CARB	FOUR BARREL CARBURETOR	EA		150

NORTHCREEK IND.	NO. 01	RESOURCE MASTER FILE MAINTENANCE EDIT LIST	DATE 8/04/**	TIME 15:41:19	PAGE 2	AML599
				USER ID TRONIE		

----- SESSION STATISTICS -----		
ADDITIONS	CHANGES	DELETIONS
1	1	1

This report shows changes made to the Resource Master file through file maintenance. The report is optional. It is printed automatically at the end of each Resource Master file maintenance session (option 1, Maintain Resource Master File, on menu AMLM30) if you selected the report as an option when you answered the questionnaire. The identifier of the planning warehouse you selected appears on the report.

Fields

WAREHOUSE. The identifier of the planning warehouse.

USER ID. The user ID of the operator who made the changes.

Type of maintenance. The kind of maintenance performed (add, change, or delete). If you changed a record, the report shows the information for that resource before and after the change.

RESOURCE NUMBER. The unique identifying number of the resource you maintained.

DESCRIPTION. A description of the resource you maintained.

UNIT OF MEASURE. The code for the unit used in measuring this resource. Your company establishes this code.

RESOURCE PER DAY. The quantity of this resource available for use during one work day. This figure may reflect average use, a maximum rate of replenishment, or a maximum capacity.

SESSION STATISTICS. A summary of the maintenance activity in this session. The figures show the total number of resources added (ADDITIONS), resources changed (CHANGES), and resources deleted (DELETED).

Resource Profile Exception Report (AML559)

NORTHCREEK IND. NO. 01		RESOURCE PROFILE EXCEPTION REPORT	DATE 8/04/**	TIME 22.34.23	PAGE 0001	AML559	
WAREHOUSE ATL PROFILES GENERATED FOR ALL ITEMS			LEAD TIME DEVIATION PERCENT				
END ITEM NUMBER	ITEM NUMBER	DESCRIPTION	-LEAD MFG	TIMES- CALC	EXTENDED QUANTITY	----- LOTSIZE	COMPONENT STD BATCH QTY
COMPACT1	COMPACT1	COMPACT AUTO (END ITEM)	17.0	2.5			
COMPACT1	AIRKIT	AIRCONDITIONER KIT (OPTION)	1.0	0.5			
COMPACT1	HOSES	AIRCOND HOSES (PHANTOM)	1.0	0.5			
COMPACT1	2D3	DOOR (2 DOOR/TYPE 3) OPT	1.0	0.5			
COMPACT1	4D3	DOOR (4 DOOR/TYPE 3) OPT	1.0	0.5			
COMPACT1	5D3	DOOR (5 DOOR/TYPE 3) OPT	1.0	0.5			
COMPACT1	INTERIOR2	BODY INTERIOR (TYPE 2)	1.0	0.3			
COMPACT1	4CYL	4 CYL ENGINE OPT	10.0	0.1			
COMPACT1	ENG4	4 CYL ENGINE ASSEMBLY	2.0	0.4			
COMPACT1	6CYL	6 CYL ENGINE OPT	10.0	0.7			
COMPACT1	ENG6	6 CYL ENGINE ASSEMBLY	2.0	1.5			
COMPACT1	TIREPKG	TIRE PKG (PHANTOM)	9.0	1.5			
COMPACT2	COMPACT2	COMPACT AUTO (END ITEM)	17.0	2.1			
COMPACT2	AIRKIT	AIRCONDITIONER KIT (OPTION)	1.0	0.5			
COMPACT2	HOSES	AIRCOND HOSES (PHANTOM)	1.0	0.5			
COMPACT2	2D4	DOOR (2 DOOR/TYPE 4) OPT	1.0	0.7			
COMPACT2	5D4	DOOR (5 DOOR/TYPE 4) OPT	1.0	0.3			
COMPACT2	INTERIOR2	BODY INTERIOR (TYPE 2)	1.0	0.8			
COMPACT2	4CYL	4 CYL ENGINE OPT	10.0	0.5			
COMPACT2	ENG4	4 CYL ENGINE ASSEMBLY	2.0	0.5			
COMPACT2	6CYL	6 CYL ENGINE OPT	10.0	0.1			
COMPACT2	ENG6	6 CYL ENGINE ASSEMBLY	2.0	1.5			
COMPACT2	TIREPKG	TIRE PKG (PHANTOM)	9.0	1.4			
COMPACT3	COMPACT3	COMPACT AUTO (END ITEM)	17.0	2.8			
COMPACT3	INTERIOR2	BODY INTERIOR (TYPE 2)	1.0	0.5			
COMPACT3	TIREPKG	TIRE PKG (PHANTOM)	9.0	1.5			
COMPACT3	4CYL	4 CYL ENGINE OPT	10.0	0.4			
COMPACT3	ENG4	4 CYL ENGINE ASSEMBLY	2.0	1.3			
COMPACT3	4D3	DOOR (4 DOOR/TYPE 3) OPT	1.0	0.2			
COMPACT4	COMPACT4	COMPACT AUTO (END ITEM)	17.0	2.1			
ENG8	ENG8	8 CYL ENGINE ASSEMBLY	2.0	1.5			
SEDAN1	SEDAN1	SEDAN AUTO (END ITEM)	17.0	2.7			
SEDAN1	AIRKIT	AIRCONDITIONER KIT (OPTION)	1.0	0.5			
SEDAN1	HOSES	AIRCOND HOSES (PHANTOM)	1.0	0.5			
SEDAN1	2D1	DOOR (2 DOOR/TYPE 1) OPT	1.0	0.5			
SEDAN1	4D1	DOOR (4 DOOR/TYPE 1) OPT	1.0	0.5			
SEDAN1	5D1	DOOR (5 DOOR/TYPE 1) OPT	1.0	0.4			
SEDAN1	INTERIOR1	BODY INTERIOR (TYPE 1)	1.0	0.5			
SEDAN1	4CYL	4 CYL ENGINE OPT	10.0	0.5			
SEDAN1	ENG4	4 CYL ENGINE ASSEMBLY	2.0	0.5			
SEDAN1	6CYL	6 CYL ENGINE OPT	10.0	0.8			
SEDAN1	ENG6	6 CYL ENGINE ASSEMBLY	2.0	1.4			
SEDAN1	TIREPKG	TIRE PKG (PHANTOM)	9.0	1.1			
SEDAN2	SEDAN2	SEDAN AUTO (END ITEM)	17.0	1.7			
SEDAN2	AIRKIT	AIRCONDITIONER KIT (OPTION)	1.0	0.5			
SEDAN2	HOSES	AIRCOND HOSES (PHANTOM)	1.0	0.4			
SEDAN2	2D2	DOOR (2 DOOR/TYPE 2) OPT	1.0	0.5			
SEDAN2	4D2	DOOR (4 DOOR/TYPE 2) OPT	1.0	0.9			
SEDAN2	5D2	DOOR (5 DOOR/TYPE 2) OPT	1.0	0.5			
SEDAN2	INTERIOR1	BODY INTERIOR (TYPE 1)	1.0	0.5			
SEDAN2	6CYL	6 CYL ENGINE OPT	10.0	0.5			
SEDAN2	ENG6	6 CYL ENGINE ASSEMBLY	2.0	0.5			
SEDAN2	TIREPKG	TIRE PKG (PHANTOM)	9.0	1.4			
SEDAN3	SEDAN3	SEDAN AUTO (END ITEM)	17.0	2.7			
SEDAN3	INTERIOR1	BODY INTERIOR (TYPE 1)	1.0	0.5			
SEDAN3	TIREPKG	TIRE PKG (PHANTOM)	9.0	1.1			
SEDAN3	4CYL	4 CYL ENGINE OPT	10.0	0.5			
SEDAN3	ENG4	4 CYL ENGINE ASSEMBLY	2.0	1.8			
SEDAN3	4D1	DOOR (4 DOOR/TYPE 1) OPT	1.0	0.5			
4D4	4D4	DOOR (4 DOOR/TYPE 4) OPT	1.0	0.5			
8CYL	8CYL	8 CYL ENGINE OPT	10.0	1.3			

21 RESOURCE PROFILE(S) GENERATED FOR DATE 8/04/**

This report informs you when:

- The manufacturing lead time calculated by the system for an item differs from the user-entered lead time by more than a specified percent
- The required quantity calculated by the system for a component item is larger than the user-entered lot size or standard batch quantity.

The report is printed whenever you generate resource profiles (option 3, Generate Resource Profiles, on menu AMLM30).

If you selected a range of planning warehouses, a separate report is printed for each warehouse that falls within that range. The warehouse identifier appears on the report.

This report helps you identify inaccuracies in the lead times and lot sizes (or batch sizes) of master scheduled item components. The report can contain information about any components of the items for which you generate resource profiles; the components do not have to use critical resources.

Note: The system may not generate a resource profile for an item or family if:

- A processing error occurs. See the errors and related information printed on this report to identify the problem.
- The item or family does not have Y (yes) for RESOURCE PROFILE BUILD FLAG in its Item Master file record.

Fields

PLANNING WAREHOUSE. The identifier of the planning warehouse.

Sequence and range used. A variable field that shows:

- The sequence you selected for generating resource profiles
- The range of numbers if you entered a range on display AML502 or AML503
- The item or production family number if you generated a profile for a single item or family.

The exact content of this field varies with the selection decisions you made on the Generate Resource Selection displays.

LEAD TIME DEVIATION PERCENT. The minimum difference between an item's calculated lead time and the user-entered lead time that causes the lead time and offset for an item to be printed on this report. This is the percent that you entered on the Generate Resource Profiles Selection display (AML501).

Note: If the Lead Time Deviation Percent is zero, lead times are printed for all items.

END ITEM NUMBER. The number of the master scheduled item or production family for which the system generated a resource profile.

ITEM NUMBER. The number of an item with a lead time deviation beyond a specified limit, a difference between the calculated requirement and the lot size, or any file condition that generated an error message. If the system is generating a profile for a master scheduled item, the item identified in this field may be the end item or any component of the end item. If the profile is for a production family, the item identified may be an end item assigned to the family or any component of an end item in the family.

DESCRIPTION. A description of the item identified in the **ITEM NUMBER** field.

LEAD TIMES MFG (Manufacturing lead time). The amount of time (in work days) required to manufacture this item from the next lower level of components. This is the user-entered amount (LTMAN) from the Item Balance file. It does not include the manufacturing lead time adjustment (LTADM).

LEAD TIMES CALC (Calculated lead time). The calculated amount of time (in work days) required to manufacture this item from the next lower level of components.

To calculate this lead time, the system uses the item's routing operations from the Routing file. For each work center operation in the routing, the system calculates the work center time (based on the extended quantity) and adds queue time and move time. It adds together the total processing times for all work centers in routings for the item. If the total is greater than the user-entered lead time by an amount equal to or greater than the deviation percent, the item number and the two lead times print.

Note: If the Lead Time Deviation Percent is zero, lead times are printed for all items.

EXTENDED QUANTITY. The quantity or amount of this component item needed to produce one standard lot or batch of the end item. For each level of components the system multiplies the lot size of the parent item by the quantity of the component needed per parent (QTYPR). That total becomes the basis for extending the quantity to the next level of components.

Note: This field can show up to three decimal positions.

LOTSIZE (Component lot size). The user-entered standard lot size (LOTSZ) for this component item, taken from the Item Master file. If this quantity is smaller than the Extended Quantity for the item, the item number and both quantities are printed on the report.

STD BATCH QTY (Component standard batch quantity). The user-entered standard batch quantity (SBQTY) for this component item, taken from the Item Master file. If this quantity is smaller than the Extended Quantity for the item, the item number and both quantities are printed on the report.

Note: This field can show up to three decimal positions.

The following information is printed as part of a comment line at the end of the report:

Number of profiles generated. The total number of resource profiles created or regenerated in this profile generation.

Effective date of generated profiles. The date that controls the Product Structure components that are included in a profile and the member items included in a production family. This date is the effective date of profiles you entered on the Generate Resource Profiles Selection display (AML501).

Chapter 9. Forms

The Resource Master file contains records for the critical resources you define. The system uses these records for generating resource profiles. If you add a resource use to a generated profile, or if you create a resource profile for an item or production family, each resource you include must have a record in the Resource Master file.

To maintain the Resource Master file, use option 1, Resource Master File Maintenance, on the Resource Profile Management menu, AMLM30.

You can use form MS-01 to define a critical resource before you enter it in the Resource Master file. The fields on this form correspond to the fields on displays "AML591—Resource Master File Maintenance (Select)", "AML592—Resource Master File Maintenance (Add)", and "AML593—Resource Master File Maintenance (Change)".

Note: The following form is not copyrighted. You may reproduce it without permission.

Resource Master File Maintenance form (MS-01)

(Display AML591, AML592 or AML593)

Resource number (N5.0) - - - - -

Planning warehouse (A3) - - -

Resource description (A25) - - - - -

Unit of measure (A3) - - -

Resource per day (N9.0) - - - - -

Appendix A. Controlling and monitoring MPSP

Master Production Schedule Planning is designed to help you meet long-range business goals, use your production resources efficiently, and generate workable, stable master production schedules. You can increase the effectiveness and value of MPSP by taking the actions outlined in this appendix.

Maintain your files carefully	A-2
Coordinate the processing dates used by MPSP activities	A-4
Monitor the operation and effects of MPSP regularly	A-5

Maintain your files carefully

Keep your MAPICS XA master files usable and complete

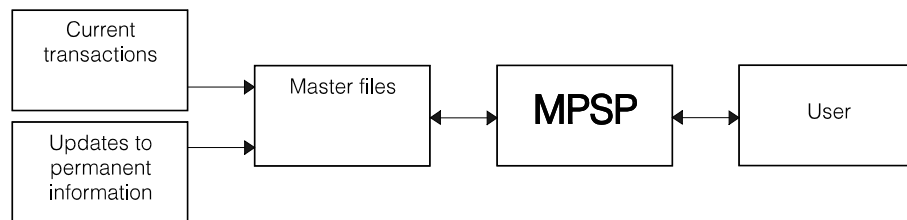

Figure A-1. Reliance of MPSP on MAPICS XA master files

As the figure above shows, MPSP depends on information from the MAPICS XA master files for most of its activities. If those master files have internal problems, such as incomplete or conflicting information, MPSP cannot be fully effective. Most MPSP activities generate error messages to identify file problems encountered. When you see those messages, identify the exact causes and correct them.

Be sure that you have entered correct information for those fields for your production families, master scheduled items, and critical resources. Lead times, lot sizes, and other planning information help determine the accuracy of your results. For MPSP, information in the Item Master, Item Balance, Product Structure, Routing, and Production Facility files is very important.

MPSP can indicate some master file information that needs attention. For example:

- The Resource Profile Exception Report (AML559) shows you when the item lead times in the Item Balance file are inconsistent with the times required by the routings and work center standards for an item. It can also show you when the lot sizes for component items are too small to support the lot size (or standard batch quantity) of the end item they contribute to. You can set a level of acceptable deviation for the difference between file lead times and calculated lead times, lowering the acceptable level of difference as you resolve the inconsistencies.
- Error Lists and activities that do on line calculations, such as available to promise, warn you when they find needed information is not in the files or when file errors make further calculations questionable.

This information can help you locate and solve problems in the master files.

You can also enhance the accuracy of the master files by:

- Using control totals and other accuracy checks in the applications that provide information for the master files
- Backing up master files regularly
- Labeling offline backup devices and archived reports carefully and consistently.

Keep the information used by MPSP up to date

Most of MPSP's activities use current information retrieved at the time the job runs. To get accurate results, you must be sure that the information MPSP retrieves is up to date.

- Enter transactions in IM, REP, PDM/EPDM, ISL/MISL (if installed), and COM (if it is installed and interfacing) carefully and process them regularly. In IM, ISL/MISL, and COM, inventory transactions and customer orders should be entered promptly so that master file information about inventory levels and customer backlog does not lag behind actual conditions. Regular period closings, though not required for MPSP's calculations, encourage prompt and regular data entry and processing. In PDM/EPDM, make changes to product structures, routings, and work center standards promptly. You may need to review your engineering change process to ensure that the data base reflects changes enacted on the production floor.
- If ISL/MISL is installed, verify when order release is run, either through MRP or ISL/MISL, that the COM offline load of intersite orders was successful. If any orders are rejected, correct the problem and re-run order release. This will assure that the requesting warehouse and the supplying warehouse are seeing accurate and timely information.
- Keep forecasts current by reloading them as soon as changes in demand cause changes in the forecasts.
- If you use the Demand Interface file for forecasts or customer backlog, reload the file regularly to keep demand information current and to support MPSP inquiries such as available to promise. If your business is volatile, a program for immediate updating from your order entry application may be more efficient than a batch-load program.
- If you use item production plans as a demand source for master scheduling, perform aggregation, family operating plan maintenance, and item trial plan maintenance regularly. You should aggregate one time per production planning period and then maintain family and item plans using the new demand and inventory information from aggregation.
- Review master production schedules for important or volatile items frequently. Between master production schedule generations, maintenance inquiries show new demand conditions that may require changes before the next schedule generation.
- Be sure that MRP uses updated master scheduled orders as often as possible. The usual frequency is one time per week. Net change runs usually do not use updated master scheduled orders because:
 - The master production schedule changes may cause too much nervousness in the MRP schedules
 - The total processing time with extensive MPSP changes may be greater than a full MRP generation.

However, if you maintain your master production schedules heavily and frequently, your MRP runs should reflect those changes as soon as possible.

Coordinate the processing dates used by MPSP activities

MPSP is date-sensitive; that is, certain dates that exist in the master files or that you enter during MPSP activities control how the application processes information. You must coordinate the various dates to get consistent, dependable scheduling results.

MPSP shows you some essential dates on the displays or reports for major activities so that you can verify them before you begin the activity or accept its results. For example, major dates appear on:

- The Planning Run Status Report (AML480), which prints after each master production schedule generation
- The Generate Master Schedules Planning Run Options display (AML410), the display on which you set conditions for the next planning run
- The Change/Display Horizon Dates display (AML601), on which you define the master scheduling horizon and specify the next period in which you aggregate.

When MPSP is installed and interfacing and you begin an MRP planning run, important reference dates appear with the confirmation prompts to help you decide whether to continue the MRP run.

Some of the most important dates you see are:

- MPS Current Date
- MPS Start Date
- MPS Cutoff Date
- Item Production Plan Date (also shown as Production Plan File Date)
- Demand File Date
- Operating Plan Date.

The relationship of these dates to each other must be correct for MPSP to function accurately. For explanations of these dates and their relationships, see the display descriptions for displays AML410 and AML601.

Monitor the operation and effects of MPSP regularly

The application provides information in a variety of forms to help you evaluate performance and identify situations that need attention:

- Error lists and error messages
- Special reports
- Lists of essential dates
- Exception codes and messages for master production schedules
- Inquiry displays.

Error lists and error messages

MPSP produces printed lists of processing and file errors after many of its activities. Error messages can print on the following reports:

- Replace Family Base Plans Error List (AML221)
- Family Operating Plan Report (AML241)
- Replace Item Production Plans Error List (AML250)
- Aggregation Error List (AML340)
- Planning Run Status Report (AML480)
- Resource Profile Exception Report (AML559)
- Job Cancellation Message Log (AXZ10RP).

In addition to the message text, the reports often print other related information, such as and file names, to help you identify and understand the problem.

Special reports

MPSP reports print information to help you monitor the application.

- The Resource Profile Exception Report (AML559), described above, identifies problems with item lead times and lot sizes.
- The Master Schedule Open Order Maintenance List (AML455) lists all changes made to open orders so that you can recreate them exactly in IM to implement the changes.
- The Resource Master File List (AML581) lets you review all of your critical resources.
- The Resource Master File Maintenance Edit List (AML599) records any changes made to your critical resources.
- The Item Resource Report (AML321) shows you whether the items you have grouped in families still use the same critical resources, and whether other items could be added to certain families on the basis of their resource use.

Watching the contents of these reports can help you confirm changes or recognize the need for changes.

Lists of essential dates

See the dates listed for "Coordinate the processing dates used by MPSP activities".

Inquiry displays

Regular use of the MPSP inquiry displays can give you much information about the status of application activities. For example:

- Display/Maintain Family Operating Plans (AML202) shows whether your cumulative production goals are equal to cumulative demand.
- Display/Maintain Item Trial Plans (AML232) shows you how far your current item production plan for an item differs from current demand levels.
- Family Plan Inquiries (AML281, AML282, AML283, AML284, AML285) show you how current family operating plans compare with previous expectations, how item production plans compare to family plan targets, and how master production schedules compare to item plans and family plans.
- Display/Maintain Master Schedule (AML452, AML453) uses exception codes to identify scheduling problems that need attention.
- Display Available to Promise (AMVATP03) shows whether you have uncommitted inventory in future periods to meet additional demand.
- Resource Requirements Analysis (AML532) shows whether the projected use of a critical resource for family operating plans or master scheduled orders is greater than the quantity of the resource available in the period.

Using the inquiry displays gives you the most current information available about balances and imbalances in your MPSP planning activities.

Other information to monitor

You can also use external information to help you evaluate how effectively you are using MPSP.

- Inventory levels. Ideally, MPSP can help you lower your inventory levels without jeopardizing production or lowering customer service. If you have set inventory goals, either in quantity or value, inventory figures help you gauge your progress.
- Production problems related to foreseeable overloads. Effective resource planning should reduce or eliminate production delays or disruptions caused by overloading critical work centers or the supplies of critical item resources. If the level of such disruptions remains high, you may need to give more attention to resource testing and resource planning.
- Number of changes to the master production schedule. Effective use of resource planning and master production scheduling should produce a relatively stable set of master scheduled orders to send to MRP. Apart from such factors as unforeseen demand changes or upper-management intervention, you should see few changes to the master production schedule after the initial generation and review. If the level of change remains high, you may need to reexamine your approach to master scheduling (for example, the demand sources used for planning). You may also need to reconsider the amount of authority given to the master scheduler to resist changes to the schedule within certain time limits (time fences).

Appendix B. Data entry in MPSP

MPSP is a planning application and, like MRP, does not require extensive data entry. Online tasks such as creating and changing plans or testing and analyzing resource needs are the major work station activities.

MPSP uses only one entry form: form "Resource Master File Maintenance form (MS-01)". You can use the form to define a critical resource before you enter the resource into the Resource Master file (option 1 on the Resource Profile Management menu, AMLM30).

MPSP uses special fields in the Item Balance, Item Plan, and Production Facility files. This section lists and describes those fields under the heading "Fields MPSP uses to support MPSP activities." You can maintain information in the Item Balance/Item Plan file using the Inventory Management application (IM). You can use PDM/EPDM to maintain information in the Production Facility file. You cannot maintain either of those files from MPSP.

Fields MPSP uses to support MPSP activities

The following paragraphs summarize the maintainable fields in the Item Plan file and the Production Facility file that have special importance for MPSP. You can enter the necessary information into both of these files to complete the records for each master scheduled item and production family.

The codes and other information you enter in these fields affect such activities as how MPSP plans orders for the item and whether you can generate a resource profile for the item. For more information about how MPSP uses these fields, see Chapter 2 of this manual.

Item Plan file: ITMPLN

Demand Time Fence (DTFD)

Use this field to define the number of days you want MPSP to use as a frozen planning zone in the master production schedule for this item. The system uses this number to calculate the Demand Time Fence Date for the item.

Master Schedule Item Code (MSIC)

Use this field to indicate whether an item is a master scheduled item or a production family. The default value is blank. The possible codes are:

- blank—not a master scheduled item. MPSP does not plan this item.
- M—Master scheduled item. MPSP plans orders for this item based on the demand source you specify in the **MPSP PLANNING SOURCE** field. The system ignores any requirements generated or entered for the item in MRP.
- P—Production family. This item is a production family. You can assign end items to this family for item production planning and for reviewing related items in family sequence.

If the master scheduled item code is P, the only valid item type code is 0 (phantom).

MPS planning source code (MSSR)

Use this code to indicate the kind of independent demand you want MPSP to use for generating the master production schedule for this item. There is no default value.

The available codes are:

- blank** Not used in MPS planning
- B** Blended demand (the greater of forecasts or customer orders/expected customer orders for the period)
- C** Customer orders/expected customer orders only
- D** Blended demand, planned orders created for each customer order
- E** Forecasts ignored, planned orders created for each customer order
- F** Forecasts only
- M** Manually entered firm planned orders
- P** Item production plan

If the master scheduled item code is M, you must enter a code in this field.

Price Break Conversion Factor (PBCF)

Use this field from Material Requirements Planning to define a critical resource in a unit other than the stocking unit of measure or to define a critical resource that is actually a group of related items with different units of measure. You can use this conversion factor to reduce the number of critical resources you must define to determine resource needs for a material that comes in different shapes and sizes. For more information, see "Using the resource conversion factor" on page 2-99.

Production Family Planner (PFPL)

Use this field to define the identifier for the person responsible for planning the replenishment strategy for the production families.

Resource Number (RSNO)

Use this field to show the unique number MPSP uses to identify this item as a critical resource. This is the number you assigned to this item when you defined it as a critical resource in the Resource Master file. The default value is blank.

Resource Profile Build Code (RSBF)

Use this field to indicate whether an item or a production family can have a resource profile generated. The default value is N. The available codes are:

- Y** Generate profile
- N** Do not generate profile

Production Facility file: WRKCTR

Labor Resource Number (LABRN) . Use this field to identify the labor hours in a work center as a critical resource. This is the number you assigned to this critical labor resource when you defined it in the Resource Master file. If you do not enter a number, the system does not process the work center as a critical labor resource.

Machine Resource Number (MACRN) . Use this field to identify the machine hours in a work center as a critical resource. This is the number you assigned to this critical machine resource when you defined it in the Resource Master file. If you do not enter a number, the system does not process the work center as a critical machine resource.

Contents	Index	Exit
--------------------------	-----------------------	----------------------

Appendix C. Creating and using the Demand Interface file

This appendix explains what the Demand Interface (DMDIFF) file is, how it is organized, and how FCST loads it for use by MPSP. If you load forecasts or customer backlog in the Demand Interface file using a non-MAPICS XA application or your own program, you must use the same format and dating techniques that FCST uses, in order for MPSP to retrieve the information accurately.

Description of the Demand Interface file.....	C-1
Demand Interface file layout	C-2
How MPSP uses the Demand Interface file.....	C-4
How Forecasting (FCST) uses the Demand Interface file	C-5
Creating the Demand Interface file	C-11
Customer backlog in the Demand Interface file.....	C-10
Loading the Demand Interface file.....	C-12
Updating the Demand Interface file	C-13

Description of the Demand Interface file

The Demand Interface file is a holding or catcher file that enables MPSP to receive forecast information for master scheduled items. It also enables MPSP to receive customer order information (customer backlog) when Customer Order Management (COM) is not installed and interfacing.

Demand Interface file layout

The table below shows the physical layout of the records in the Demand Interface file. Each record contains data fields and arrays of up to 91 quantities per record. These arrays contain the forecast or backlog quantity per period through a maximum time span of three years.

The table below also identifies the kinds of information FCST puts into the fields and arrays. If you load customer backlog in the file, you must follow the same format and the same dating principles that FCST uses for forecasts. Later explanations tell how FCST distributes the forecasts and how it assigns dates to the arrays in each record.

Record length: 404
 Key length: 191
 Key start: 1

Field description	From	To	Dec pos	FMI	Field name
Item number	1	15		A	ITNBR
Warehouse	16	18		A	HOUSE
Demand type code	19	19		A	DMTYP
Weekly demand (52 periods, 7 bytes each)	20	227	O	P	WKYDM
Year 2 and 3 (26 periods, 7 bytes each)	228	331	O	P	YR2DM
Year 1 demand (13 periods, 7 bytes each)	332	383	O	P	YR1DM
Overdue backlog quantity	384	387	O	P	ODUEQ
Option item's parent's lead time	388	389	O	P	OPTLT
End item number	390	404		A	ENDIT

Fields

Item number. The number of this item in the Item Master file.

Warehouse. The MRP planning warehouse for this item.

Demand type code. The type of demand in this record.

Note: This field is part of the key, which is item number (ITNBR) + warehouse (HOUSE) + demand type (DMTYP).

Use one of the following codes:

- blank** Customer backlog from direct sales of this item
- F** Forecast demand for direct sales of this item
- G** First option backlog record from the direct sales of a model that requires this option item
- H - Z** Additional option backlog records for the same option used
- 0 - 9** with a different parent

Weekly demand. An array of 52 elements containing the demand in the YR1DM array converted into weekly quantities. MPSP uses this weekly demand in master scheduling.

Years 2 and 3 demand. An array of 26 elements containing the demand for each production planning period in years two and three of the production planning horizon.

Year 1 demand. An array of 13 elements containing the demand for each production planning period in the first year of the production planning horizon. When FCST loads forecasts, it begins with this array. Some or all of the demand in this array is restated in weekly quantities in the WKYDM array, based on the number of periods you specify for conversion when you answer the FCST questionnaire.

Overdue backlog quantity. The total quantity of customer backlog due before the beginning date of the first element in the WKYDM (weekly demand) array. This beginning date is the First Demand Period Date, sometimes also shown as the Demand File Date. FCST sets this date each time it loads the Demand Interface file.

The last two fields apply only to options for which you are entering backlog:

Option item's parent's lead time. The lead time in days for this option item relative to its parent (a model). The lead time is equal to the option item's Lead Time Adjustment (LTADJ) in the Product Structure file. If LTADJ is zero, use the lead time for the model (LTMAN + LTADM).

End item number. The number of the end item (model) for which this item is an option.

How MPSP uses the Demand Interface file

If FCST is installed and interfacing, it creates and loads the Demand Interface file with forecast records for each master scheduled item that has a forecast code of 2 or 3 and a master scheduled item code of M. MPSP then can get forecasts for the item from this file. If COM is not installed and interfacing, MPSP also looks for customer backlog information in the Demand Interface file. If COM is installed and interfacing, MPSP retrieves customer backlog data directly from the MAPICS XA data base.

The demand arrays (WKYDM, YR2DM, and YR1DM) can contain forecast or backlog information. The demand type code in each record determines whether MPSP uses the information in that record as forecasts, customer backlog, or option backlog.

The production planning functions of MPSP use forecasts and customer backlog information during the aggregation of production family members. MPSP blends the aggregated demand information for each production planning period. If forecast or customer backlog information for an item is not available, MPSP assumes the forecast or backlog for that item to be zero.

However, the master scheduling functions of MPSP retrieve forecast data only for master scheduled items that require forecast data. Similarly, MPSP looks for customer backlog in the Demand Interface file only if COM is not installed and interfacing and master scheduled items require customer backlog information. The MPS planning source code in the Item Planning (ITMPLN) file record for each item determines the kind of demand information it requires:

- An item requires forecasts if its code is F (forecasts only), B (blended), or D (blended demand, planned order created for each customer order).
- An item requires customer backlog information if its code is C (customer orders only), B (blended), or E (forecast ignored, planned order created for each customer order).

You need to load forecasts into the Demand Interface file if FCST is not installed and interfacing and you want to use forecasted demand. You need to load customer backlog into the Demand Interface file if COM is not installed and interfacing and you want to use customer backlog for demand. If you need to load either forecasts or backlog into the Demand Interface file, read all of this appendix.

If you are loading forecasts into the Demand Interface file, the forecasts should not include intersite orders, as MPSP adds the current projected demand for intersite orders to any forecast you load or that is loaded by FCST. MPSP gets its projected demand directly from the planning system of the requesting warehouse, and lots it into MPSP as both forecast demand and order demand, so it is always included in blended demand.

Note: You need to update the Demand Interface file on a timely basis to ensure the validity of the FIRST DEMAND PERIOD DATE field in the Planning Information file. This field is important for scheduling and planning, but is used only if the Demand Interface file exists. If you stop using this file for some period of time, you should remove it from the system to remove the invalid First Demand Period Date in the Planning Information file.

How Forecasting (FCST) uses the Demand Interface file

For each master scheduled item that receives a forecast, FCST creates a record with item identification, a demand type code of F (forecasts), and three arrays. Two of these arrays (YR1DM and YR2DM) support production planning and hold forecasts for up to 39 production planning periods. Two of the arrays (YR1DM and WKYDM) support master scheduling. The Weekly Demand array (WKYDM) is loaded with up to 52 weekly quantities derived from the period forecasts in the First Year Demand array (YR1DM).

The elements in these arrays do not include dates. MPSP and FCST use implied dates for the elements based on an anchor date (FDPD) in the Warehouse record in the Planning Information file.

Because the dates do not appear, you must understand:

- How FCST loads forecasts into the array elements
- How FCST associates dates with array elements
- How the dates for WKYDM array elements can change.

The production planning arrays (YR1DM and YR2DM)

Based on the number of years you forecast, FCST loads the YR1DM and the YR2DM arrays with forecasts for up to three years. It loads the first year's forecasts into YR1DM array, and the remaining forecasts into YR2DM array. The type of production planning period you use determines how many elements FCST can load in each array:

- If you use 13 periods per year, FCST loads 13 elements in YR1DM and up to 26 elements in YR2DM. MPSP checks all 39 elements when it retrieves information from the file.
- If you use 12 user-defined periods or monthly periods, FCST loads 12 elements in YR1DM and up to 24 elements in YR2DM. The last element in YR1DM and the last two elements in YR2DM remain empty. MPSP ignores those elements when retrieving information from the file.

Production planning periods (multi-week periods)

MPSP provides three types of multi-week periods for use in forecasting and in production planning. The type you choose affects the length and the specific starting date of each forecasting (and each production planning) period. The three types of forecasting and production planning periods are:

- Thirteen periods per year

The year is divided into thirteen 4-week periods. Each period begins on the first day of a planning week; every fifth week begins a new period.

- Twelve periods (user-defined) year

The year is divided into twelve periods of four or five weeks each. When you answer the MPSP or FCST questionnaire, you determine how many weeks are in each period by entering a sequence of two four-week periods and one five-week period per quarter. For example, entering 4-5-4 for the first quarter means that the first period has four weeks, the second period has five weeks, and the third period has four weeks.

Each period begins on the first day of the planning week. All three years in the production planning horizon use the sequence you specify in the questionnaire.

- Twelve monthly periods per year

The year is divided into twelve monthly periods. Each period is a calendar month, beginning on the first day of the month and ending on the last day of the month. The monthly period beginning date is not based on the first day of the planning week.

Planning Information and Calendar date records

MPSP and FCST need many period beginning dates and week beginning dates. A system function creates these dates and stores them in files when you perform calendar file maintenance by selecting Work With Calendars in IM or MRP.

Four files hold the period beginning dates, week beginning dates, work days per period, and work days per week records for each calendar that is associated with a planning warehouse or a production line.

The exact beginning date for each period depends on the type of production planning period you use and the first day (week beginning day) of your planning week. You choose the type of production planning period and the beginning day of the scheduling week when you answer the MPSP or the FCST questionnaire.

The table below list the files where this information is recorded. These records help determine the dates associated with all the arrays in the Demand Interface file:

Physical file	Logical file	Type of data in file (For entire MAPICS XA 5-year calendar)
PBDATE	PBDATELO	Period beginning dates (60 to 65 dates)
WORKPP	WORKPPL0	Work days per period (60 to 65 periods)
WBDATE	WBDATELO	Week beginning dates (260 dates)
WORKPW	WORKPWLO	Work days per week (260 weeks)

Demand File Date (FDPD)

The Demand File Date (FDPD) is located in the Warehouse record of the Planning Information file. MPSP and FCST use this date, with the other Calendar record dates described above, to determine the dates to associate with the arrays in the Demand Interface file. The Demand File Date is the anchor date for all dates related to the demand arrays. FCST sets the First Demand Period Date each time it loads forecasts into the DMDIFF.

FCST resets this date each time you use FCST to load forecasts (option 5, Forecast Load to Master Schedule, on the FCST Period Update menu, AM2M20). This date is

the first day (week beginning day) of the first planning week in the first period for which forecasts are loaded.

YR1DM and YR2DM array dates

Period beginning dates for the YR1DM and YR2DM arrays start from the first period to be forecasted and continue with the sequential period beginning dates as defined in the Calendar record. Every array element in YR1DM and YR2DM has an implied date regardless of whether FCST loads a forecast quantity into it.

Note: A forecast quantity of zero is treated as zero for that period and does not change the forecast interval.

WKYDM (weekly demand array) dates

After FCST has loaded the YR1DM and YR2DM arrays, it must convert the forecast quantities in the YR1DM array into weekly quantities and load them into the Weekly Demand array (WKYDM). The date for the first element in the WKYDM array is the Demand File Date (FDPD), which is the first weekly beginning day for the first period that FCST loaded in the YR1DM array. FCST assumes dates for all the other elements based on week beginning dates as defined in the Calendar record. Every array element in WKYDM has an implied date regardless of whether FCST loads a forecast quantity into it.

Note: If you use monthly forecasts, read “Converting forecasts to weekly forecasts with the first year” later in this appendix for information about array dates that may change in the WKYDM array.

Converting forecasts to weekly forecasts within the first year

Not all forecasts in the first year demand array (YR1DM) have to be converted to weekly forecasts. FCST lets you specify the number of forecast periods that you want restated as weekly quantities and loaded into the WKYDM array. You set that limit by answering questionnaire question on the number of first year period forecasts to be converted to weekly forecasts. If you do not specify a number of production planning periods to convert, FCST loads all 52 elements with weekly quantities.

If you specify less than a full year for conversion to weekly quantities, FCST stops loading weekly quantities at the end of the period you specify and must transfer the remaining forecast quantities in the YR1DM array into the WKYDM array for the remainder of the first year. This conversion of forecasts from the YR1DM array to the WKYDM array is not complex if you use 13 periods or 12 user-defined periods per year. However, if you use monthly periods, the conversion can cause dates for some elements of the WKYDM array to change; and the calculation of weekly forecasts becomes complex.

Monthly periods begin on the first day of each calendar month, and the first days are not necessarily week beginning days. When a week extends across monthly boundaries, the forecast for the week actually contains a portion of the forecast from each month. It is not necessary to understand the calculation that FCST uses to convert the monthly forecasts (see “Loading the forecast to the master schedule” in the Forecasting User’s Guide for more information about the calculation). What is important is to understand how the dates associated with the WKYDM array change.

Conversion for 12 or 13 periods per year

If you do not use monthly periods, the dates for the WKYDM array are not ever modified. Each forecast period in the YR1DM array has a WKYDM period beginning date associated with it, and both periods begin on the same period beginning day.

Figure C-1 shows the conversion of YR1DM forecasts for loading to weekly periods in WKYDM. The First Demand Period date (FDPD) for the example is 1/7, the forecasting periods are four weeks each (13 periods per year), the week beginning day is Monday, and the user has specified converting the first three forecasting periods into weekly forecasts.

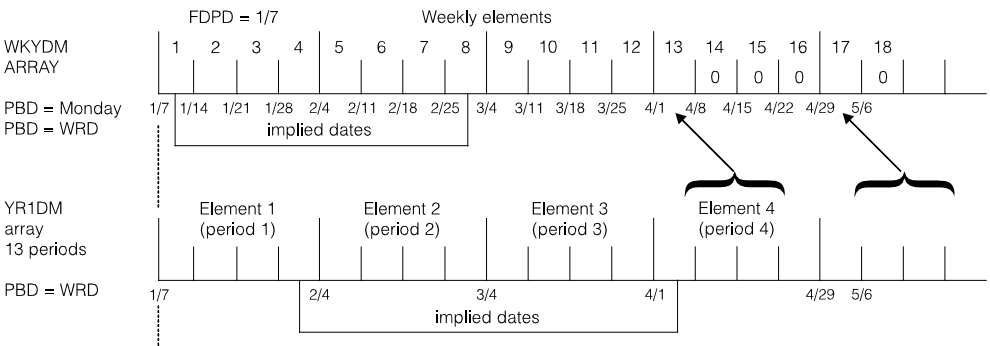

Figure C-1. Converting YR1DM forecasts to weekly forecasts for non-monthly periods

The transition occurs at element 13 in the WKYDM array. In element 13 of WKYDM, FCST loads a forecast quantity equal to the forecast for period 4 of YR1DM. It is due on 4/1, the beginning date for weekly period 13 and for production planning period 4. FCST loads zeros into the remaining weeks in the period (WKYDM elements 14, 15, and 16). The next WKYDM element to get a forecast quantity is element 17, the first weekly element in the next production planning period. FCST loads element 17 with the total demand for period 5 in the YR1DM array and loads zeros in all other weekly elements in that production planning period. This method continues until the end of the YR1DM array.

Conversion for monthly periods

FCST loads the first period's forecast into the first element of the YR1DM array. The forecast covers the entire month (from the first to the last day of the calendar month). However, the monthly array date and the weekly array dates may not match. For example, if the first week beginning date for the month is on the fifth of the month, the second WKYDM element would be dated the twelfth of the month, and so on. However, the forecast associated with the first four days of the month does not reflect anywhere in the WKYDM array because the first WKYDM array element for the month does not begin until the fifth of the month.

If the last day of the month falls in the middle of a week, the forecast for that week includes a portion of the next month's forecast, based on how many work days of the next month are in this week. This overlapping can occur for every forecasting period that is converted to weekly forecasts except the last month's forecast in the YR1DM array (element 12). If the last day of that period falls in the middle of a week, the last

weekly forecast for that period does not include any portion of the forecast for the next forecasted month (located in the first element in the YR2DM array).

If FCST converts all 12 months to weekly forecasts, none of the dates associated with the WKYDM array changes. However, if FCST converts fewer than 12 months, some week beginning dates in the WKYDM array changes to period beginning dates (the first day of the calendar month).

Changing dates in the Weekly Demand array (WKYDM)

If you convert less than the first full year of forecasts to weekly quantities, and if you use monthly forecasting periods, the dates associated with certain weekly array elements may change. The first week beginning date in WKYDM for each month not converted to weekly forecasts (except the first one) changes to the first day of the corresponding calendar month. These changes do not occur if you use 13 periods or 12 user-defined periods per year.

At the transition from weekly to monthly forecast quantities, the first monthly period begins on the first week beginning day in that month. FCST subtracts from the monthly forecast any quantities allotted to days of the month before that first week beginning day. FCST loads the reduced monthly forecast into the first WDYDM array element for that month. That element's date remains unchanged.

After the transition month, FCST changes the date of the first weekly element in each month to equal the first day of the month. Then it loads the full month's forecast into that weekly element. As described earlier, after the transition to production planning periods in WKYDM, each weekly element other than the first element in each production planning period gets a forecast quantity of zero.

Figure C-2 shows an example of these changes:

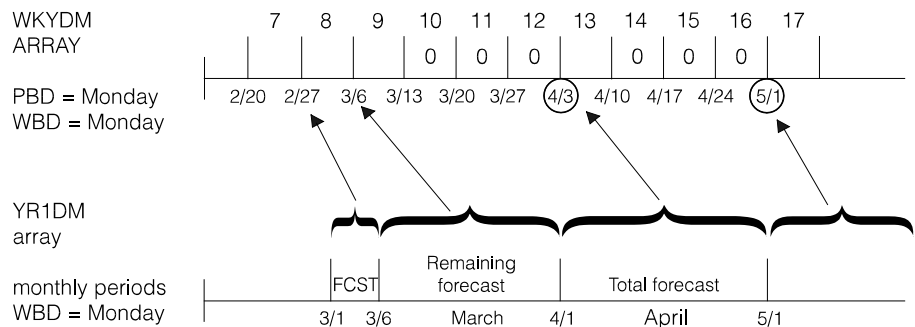

Figure C-2. Changing WKYDM array dates to fit monthly periods

In Figure C-2, the transition from weekly to monthly forecast quantities occurs after month 2, the last production planning period converted to weekly forecasts. The first week beginning date in month 3 is 3/6; therefore, FCST reduces the forecast for month 3 by the forecasts allotted to days 3/1 through 3/5 and includes that quantity in the forecast for the week beginning 2/27 (WKYDM element 8). The reduced quantity for month 3 is loaded into WKYDM element 9, the first weekly element beginning in month 3. The date of that weekly element remains 3/6. The other weekly elements in month 3 (elements 10, 11, and 12) get forecast quantities of zero.

FCST changes the date for weekly element 13, the first weekly element in month 4, to 4/1 and loads the total forecast quantity for that month into element 13. All other weekly elements for the month (elements 14, 15, and 16) get forecasts of zero. FCST changes the date for the first weekly element of each remaining month in year 1 to the first day of the month and loads that month's total forecast into the element, with zeroes for all other weekly elements in the month.

Note: In this example, the date for weekly element 17 does not change because its weekly date already matches the first day of the corresponding monthly period.

Customer backlog in the Demand Interface file

Customer backlog

If COM is not installed and interfacing and you want to use customer backlog for scheduling or for inquiries, you must enter the backlog into the Demand Interface file. If you have master scheduled items that are options, you must create separate records for direct customer demand and for generated option demand. The option demand records require additional information and special keys to ensure their proper use.

If COM is not installed and interfacing and SA transaction are not being processed to represent sales transactions through IM, the ITEMPL fields CRPLB, CRPLA, SALBF, and SALAF must be updated by the user's program. For more information on these fields, refer to "Consuming the item production plan and item blended demand (RCPLB, RCPLA, SALBF, SALAF)" on page 2-14 and "Consuming forecasts (CRPLB and CRPLA)".

Option backlog

Optional. You must create an option backlog record for each use of an option in a different model. That is, if two different models (end items) use the same option item, you must have a separate option backlog record for each use: the End Item Number, the Item's Parent's Lead Time, and the option item's key is different because of the different uses.

Special information to enter

For an option item, you must enter the following special information in the Demand Interface file record:

- A demand type code (DMTYP) of G through Z or 0 (zero) through 9 for the option item's use with a specific model (end item). Use G as the demand type code for the option's first use with a model. For its use with a different model, enter H as the demand type code. Enter a different demand type code for each use of the option with a different model. Be sure to assign the codes in strict alphabetic sequence, followed by the numeric sequence if needed.

These letters are part of the key for the option item. They allow MPSP to process the backlog for each use of an option separately and pair the backlog with the generated option forecasts resulting from planned orders for the model (end item).

- Item's Parent's Lead Time. You must enter the lead time of the option item from the model that is its parent. Use the Lead Time Adjustment (LTADJ) for the item from the Product Structure file. If the Lead Time Adjustment is zero, use the lead time of the item's parent.
- End Item Number (ENDIT). You must enter the item number of the model that is the parent of the option item. The lead time you entered in the previous field must apply to this parent.

Creating the Demand Interface file

Creating the file with FCST installed and interfacing

When you have FCST installed and interfacing, you do not create the Demand Interface file directly. FCST creates it according to the conditions you specify when you answer the questionnaire. However, before you can begin using the Demand Interface file, you must do the following:

- Review the Forecasting questionnaire to indicate that FCST should load the Demand Interface file. Be sure that you have answered all related questions about the type of multi-week (production planning) periods you use and the number of periods you want converted to weekly forecasts.
- Understand the dates associated with the array elements, especially if you intend to load backlog into the file.

Creating the file without FCST installed and interfacing

If FCST is not installed and interfacing, you must create and load the Demand Interface file. You must load:

- Forecasts if you want to use forecasted demand
- Customer backlog if you want to use customer backlog demand and COM is not installed and interfacing.

Do the following:

- Create the Demand Interface file from AMXLIBx (install/tailor) to AMFLIBy (master files).

```
CRTDUPOBJ OBJ (DMDIFF) FROMLIB (AMXLIBx) OBJTYPE (*FILE) TOLIB (AMFLIBy) NEWOBJ (DMDIFF)
```

Note: The **x** represents a program library suffix and the **y** represents a file library suffix. You add suffixes to program and file library names if you install your applications in nonstandard MAPICS XA environments. When you define nonstandard environments during Initial Application Installation or using the extended environment support function, you can assign any letter of the alphabet as a library name suffix. Program and file library names in the standard environment do not have suffixes.

- Add a physical file member to the file by typing in the following on the Command Entry display:

```
ADDPFM FILE(AMFLIBy/DMDIFF) MBR(DMDIFF)
```

and press ENTER.

- Create a record for each item that uses forecasts or customer backlog information for planning or scheduling. For each record, be sure to enter the correct demand type code to indicate the kind of demand it contains.
- Prepare forecasts and customer backlog for loading.

Note: If FCST is not installed and interfacing, you must convert all of the first year's forecasts in YR1DM to weekly forecasts in WKYDM.

Loading the Demand Interface file

When you load forecasts or backlog into the Demand Interface file, you must load the information just as FCST would. You must assign dates to array elements and load all forecasts using the techniques described in this appendix to get valid planning and scheduling results in MPSP.

Before you load the Demand Interface file, you should check to be sure that no interactive jobs are using the file when you begin the loading.

Note: You can prevent MPSP from using the Demand Interface file while you are loading it by calling your loading procedure AM2P25. Then MPSP recognizes your program as a conflicting activity.

Loading forecasts

When FCST is installed and interfacing, you load the Demand Interface file by selecting option 5, Forecast Load to Master Schedule, on FCST's Period Update menu (AM2M20). FCST sets the First Demand Period Date with the date of the first period containing forecast information.

If FCST is not installed and interfacing, be sure that you do both of the following when you load forecasts:

- Set on the Forecast Activity Flag (FCAF) in the Warehouse record of the Planning Information file to indicate that the forecasts have changed. This indicator required you to extract new demand information for the next MPSP planning run.
- Set the **FIRST DEMAND PERIOD DATE (FDPD)** field in the Warehouse record of the Planning Information file. This date, the anchor date for all demand arrays in the Demand Interface file, must be the first week beginning day for the first period you load with forecasts.

Loading customer backlog

If the Demand Interface file is to contain only customer backlog, set the First Demand Period Date in the Planning Information file as described for loading forecasts.

Loading backlog arrays

You must be sure to load backlog into the correct arrays for its use in MPSP:

- To have backlog available for production planning, you must load backlog into the First Year Demand (YR1DM) array and the Second and Third Year Demand (YR2DM) array.

- To have backlog available for master scheduling and for available to promise calculations, you must load backlog into the Weekly Demand.

Special considerations for loading backlog

When you load the demand arrays, follow FCST's practices:

- Load all quantities into the arrays using the dates associated with each element as determined by FCST and MPSP.
- If you use 12 user-defined periods or 12 monthly periods per year, do not load backlog into the last element of the YR1DM array or into the last two elements of the YR2DM array. Load those elements only if you are using 13 four-week periods per year.
- If you use monthly forecasting periods and are converting fewer than 12 monthly periods into weekly periods, observe any changes in the dates associated with the first WKYDM element for each new month.

Updating the Demand Interface file

To update the Demand Interface file, you must use the same methods that you followed in the initial loading. The frequency of updating varies with the type of demand being loaded and with your business procedures.

- Normally, you do not reload forecasts more than one time a month. If demand or other factors do not change significantly, you may reload forecasts even less often.
- You must reload customer backlog often and regularly to have current demand information for planning, master scheduling, and inquiries. In addition, you should reload customer backlog:
 - Whenever you reload forecasts
 - When you change the First Demand Period Date (appears as the Demand File Date on some MPSP displays and reports)
 - When you change the number of periods to be planned in weeks
 - When FCST (if it is installed and interfacing) changes anything that might affect the implied dates of any arrays.

You may need to reload customer backlog many times for every reloading of forecasts.

When you reload the file using your own programs or non-MAPICS XA applications, be sure that you reload every element of every record. FCST does not delete backlog records as part of the reloading process.

Note: You may choose to update records online rather than totally reloading the file. You can do that by creating an interface between COM and the Demand Interface file.

Contents	Index	Exit
--------------------------	-----------------------	----------------------

Appendix D. Sequenced tasks for installing and using

To help you install and use the MPSP application, this section divides the tasks you need to perform into three categories (subsections):

- Preinstallation activities
- Installation activities
- Processing activities.

Note: Because MPSP activities are cyclical, no separate category is necessary for periodic activities. They occur as needed in connection with normal processing tasks.

Each subsection lists tasks that need to be performed and decisions you need to make. Numbered activities appear in a suggested chronological sequence. Other activities can occur in any order, and you can carry out a number of activities at the same time.

Preinstallation activities

This discussion includes the following topics:

- General preinstallation activities
- Resource planning preinstallation activities
- Production planning preinstallation activities
- Master schedule planning preinstallation activities
- Concluding preinstallation activities.

Note: Read all of the preinstallation activities in this list, even if you do not intend to use all of MPSP's major functions (subsystems). Some preinstallation activities affect more than one subsystem.

General preinstallation activities

- Designate the implementation team members.
- Educate the implementation team. Team members should receive classroom education and should be introduced to all reference materials.
- Identify who is responsible for each of the three main subsystems:
 - Resource planning
 - Production planning
 - Master schedule planning.
- Identify MAPICS XA security levels and determine user security assignments.
- Review the interfaces for each of the MAPICS XA applications that MPSP interfaces with.
- Review your MPSP, MRP, and FCST questionnaire responses to determine application dependencies.
- Determine whether you should use the production planning subsystem immediately or if you should implement it in the future. If you are not implementing it now, you may omit the discussion of production planning in the "Installation" subsection.
- If you are not using the production planning subsystem, decide whether you want to use resource planning for testing the master production schedules. If you do not want to test resources for your master production schedules, you may omit the discussion of resource planning in the "Installation" subsection.

Resource planning preinstallation activities

- Identify resources that are critical to your manufacturing process and that need to be measured in resource planning.
- Determine how much of each critical resource you consume on a daily basis.
- Identify where in the data base you need to enter the critical resource numbers—in the Item Master file, in the Production Facility file, or in both.
- Identify any conversion factors you may use to group items with different units of measure into one critical resource for resource planning.
- Determine what additional resources you need to include in user-created profiles or add to generated profiles.

Production planning preinstallation activities

- Determine where you should get demand information. Does it come from Forecasting (FCST), Customer Order Management (COM), or your own applications? If demand information comes from your own applications, determine whether programs that load the Demand Interface file is written internally or by a third party.
- Evaluate how realistic your forecasts are. If your forecasts are unrealistic, set guidelines for making them more accurate.
- Determine the approximate number of production families you should work with and the kind of end items you want to include in each family.
- Create a numbering convention to identify the families within the Item Master file. Determine whether you want to group families by planner numbers.
- Consider approximately how many end items are in a family, and determine the quantity significance to be used for each family.
- Determine the number of multi-week periods to be included in the planning horizon for production planning and master scheduling planning.
- Determine how many weekly periods you want to have in your master production schedules.
- Determine the type of multi-week planning period to use: 12 months per year, 13 four-week periods per year, or user-defined periods of four or five weeks each.

Master schedule planning preinstallation activities

- Determine the items that are master scheduled and their source of demand. Is the source of demand item production plans, forecasts, customer orders, manually entered firm planned orders, or blended demand?
- Determine whether you need to restructure your planner numbers to distinguish master level items (MLI) from master scheduled items (MSI) when you retrieve items in planner sequence.
- Determine whether you should continue to plan any MRP MLI items in MRP using manual requirements and forecasts generated by FCST.

Concluding preinstallation activities

- Develop run schedules for the following activities:
 - Provide new forecasts
 - Develop new production targets
 - Maintain item trial plans
 - Maintain master production schedules
 - Maintain resource profiles.
- Identify areas where you would like to supplement the standard reports using Data File Utility.

Contents	Index	Exit
--------------------------	-----------------------	----------------------

Appendix E. Security areas

The options on the CAS Security Maintenance menu (AMZM38) allow you to protect application tasks from unauthorized users. You can define security areas and then define specific tasks associated with each area.

Security areas protect access to a group of menu options. The following table shows the application security areas and their associated menu options and task IDs. To print a report of all application areas, see the description of the Generate reports option in the Security Maintenance chapter of the CAS User's Guide.

The warehouse security feature to allows you to secure functions by user within warehouse. If your installation is utilizing the warehouse security feature, you can authorize users by warehouse to the appropriate task (inquiry or update) to perform any MPSP menu options.

Security area	Menu/option	Description	Task ID
Available to Promise	AMLM20/6	Available to Promise	AMLM2006
	AMLM00/4	Available to Promise	AMLM0004
Family Operating Plan Reports	AMLM10/9	Family Operating Plan Report	AMLM1009
Maintaining Master Schedule	AMLM20/2	Display and Maintain Master Schedules	AMLM2002
	AMLM20/3	Test Master Schedule Resources	AMLM2003
	AMLM20/4	Display Resource Requirements	AMLM2004
	AMLM20/5	Master Schedule Planning Report	AMLM2005
Master Schedule Generation	AMLM20/1	Generate Master Schedules	AMLM2001
	AMLM00/5	Change/Display Horizon Dates	AMLM0005
Planning Production Families	AMLM10/1	Aggregate to Production Families	AMLM1001
	AMLM10/2	Display and Maintain Family Operating Plans	AMLM1002
	AMLM10/3	Test Family Operating Plan Resources	AMLM1003
	AMLM10/4	Display Resource Requirements	AMLM1004
	AMLM10/6	Replace Family Base Plans	AMLM1006
	AMLM10/8	Family Plan Inquiries	AMLM1008
	AMLM10/10	Display and Maintain Production Families	AMLM1010
	AMLM20/07	MRP Item Inquiry	MRPITMINQ
Planning Production Items	AMLM10/5	Display and Maintain Item Trial Plans	AMLM1005
	AMLM10/7	Replace Item Production Plans	AMLM1007
Resource Planning Reports	AMLM30/2	Resource Master File List	AMLM3002
	AMLM30/5	Item Resource Report	AMLM3005
Resource Profile	AMLM30/1	Maintain Resource Master File	AMLM3001
	AMLM30/3	Generate Resource Profiles	AMLM3003
	AMLM30/4	Display and Maintain Resource Profiles	AMLM3004

Contents	Index	Exit
--------------------------	-----------------------	----------------------

Glossary

This glossary defines terms that are important for this book. It does not include all MAPICS terms nor all terms established for your system. If you do not find the term you are looking for, refer to the Index in this book, to glossaries in other MAPICS publications, or to the IBM Dictionary of Computing, SC20-1699.

This glossary includes definitions from:

- The American National Dictionary for Information Processing Systems, copyright 1982 by the Computer and Business Equipment Manufacturers Association (CBEMA). Copies may be purchased from the American National Standards Institute, 1430 Broadway, New York, New York 10018. Definitions are identified by symbol (A) after definition.
- The ISO Vocabulary – Information Processing and the ISO Vocabulary – Office Machines, developed by the International Organization for Standardization, Technical Committee 97, Subcommittee (1) Definitions of published sections of the vocabulary are identified by symbol (I) after definition; definitions from draft international standards draft proposals, and working papers in development by the ISO/TC97/SC1 vocabulary subcommittee are identified by symbol (T) after definition, indicating final agreement has not yet been reached among participating members.

activity. A quantity used by MRP to calculate available inventory. Activity is the difference between current shipments and current receipts since the last planning run.

adjusted quantity per. The quantity of the component item required to make a standard batch quantity of the parent item. This number includes adjustment for operation yield.

adjustment. (1) A transaction that changes a specific balance in a master file, such as the quantity on-hand of an inventory item. (2) In MPSP, the shipment of production quantities among periods in an item trial plan to achieve level production or build held inventory against later demand. (3) In payroll applications, an amount added to gross or net pay.

aggregation. In MPSP, the process of combining and summarizing item-level information (demand, inventory, production) to the production family level.

allocation. (1) The process of offsetting transaction allocation balances (typically cash and credit notes) against transaction settlement balances (typically invoices). (2) The reserving of available inventory for a requirement, such as an explicit open production order.

application. The use to which an information processing system is put, for example, a payroll application, an airline reservation application, a network application, keeping track of a company's inventory. (2) A program that performs a particular data processing task; for example, one that provides an inventory report or payroll checks.

application tailoring. The process of selecting, using a questionnaire, the application options that satisfy the specific needs of a company.

assembly. The combination of two or more items to make a new item.

audit trail. (1) Data, in the form of a logical path linking a sequence of events, used for tracing the transactions that have affected the contents of a record. (2) Information that allows you to trace the history of an account, item record, order, and so forth. the more recent information may be stored online so you can retrieve it.

available. (1) In MRP, the quantity of material on-hand minus the quantity allocated to open order minus "activity." See activity. (2) In MPSP, the on-hand quantity minus current allocations.

available to promise. The uncommitted portion of a company's inventory or planned production. MPSP calculates this quantity by period.

average cost. The cost of each piece of an item in inventory, arrived at by dividing the total value of the item by the number of pieces in inventory.

backlog. Customer orders or customer backlog of orders not yet filled.

balance. In MPSP, the quantity of items in a production family that is unassigned to item production plans at the beginning of the first period of the family operating plan.

base plan. See family base plan.

bill of material. A list of raw materials or components and the quantities needed to make an item, assembly, or end production.

blanket order. A purchase order allowing multiple shipments, or releases, of an item over time.

blended demand. The greater of forecasted demand or customer backlog for a planning period. MPSP can calculate this quantity by period for use in production planning and master scheduling.

calendar. MPSP and MRP use a five-year calendar to retrieve order dates. You enter the workdays, nonworkdays, and holidays into this calendar through MRP or IM (Inventory Management).

capacity. A measure of the ability to absorb orders released to the shop floor.

CMLT Time Fence. A planning boundary marking the end of the cumulative material lead time (CMLT) for an item. Master schedule changes after (outside) this time fence are relatively easy to make: changes before (inside) this time fence are more difficult and disruptive.

component. An item used to make a higher level item.

component lead time adjustment. The number of shop days before the due date of the parent item that this component must be available for the assembly of the parent.

critical resource. An essential part of your production process (usually an item or a work center) that you want to monitor because it affects production flow or production levels. An item or work center may be critical because it “bottlenecks” production, or because its cost or quantity affects overhead or inventory levels to an unusual degree. In MPSP critical resources are the basis for resource planning.

cumulative check. In MPSP, a calculation that determines by period whether the cumulative planned production for a family is equal to the cumulative net demand for the items in that family.

cumulative material lead time (CMLT). The total lead time required to produce this item, including time to purchase parts and raw materials.

current date. In MPSP and MRP, a user-entered date that identifies the current period in the planning horizon. The current dates enable the user to align the MPSP and MRP planning horizons when both applications are installed and interfacing.

current unit cost. The sum of current purchase labor and overhead content for this and lower levels of this item.

default. An alternative attribute, option, or value that is assumed when none has been specified.

demand. The required shipment of an item in a specific time period. Orders for shipment in some future time period are not considered part of the current period’s demand.

demand source. See planning source.

Demand Time Fence. A planning boundary marking the end of the “frozen” phase of a production scheduled. Any changes before (within) the Demand Time Fence are extremely difficult and disruptive. This time fence can mark the limit of the final assembly lead time (FALT) for an item.

discrete order quantity. A rule for determining order size using the period’s net requirements as a lot size.

due date. (1) The date by which a planned or firm planned order or an open order is to be completed or a purchase order is to be received. (2) The date inventory is consumed to satisfy a requirement.

effective date. The date an engineering change is designated to become effective.

end item. (1) The product shipped to the customer. (2) In MPSP, any item that is not a component of another item.

engineering change (EC). A change made to an item to reduce its cost or improve its function, serviceability, or safety.

enter. To send coding, data, or a message to a computer from a keyboard.

error message. An indication that an error has been detected. (A) Contrast with informational message.

exception codes. Single letter alphabetic indicators identifying special planning conditions that need attention.

exception messages. Messages identifying special planning conditions that need attention.

expected customer order. A schedule of planned purchase orders transmitted electronically from a buyer to a seller using EDI transaction 830 (ANSI X.12) or DELFOR (EDIFACT). In MAPICS, the name for the transaction received from customers.

expected receipts. All inventory replenishments scheduled for an item, including open orders and firm planned orders. In MPSP, "expected receipts" for available to promise also include planned orders.

explosion. The calculation of how many of each of the items listed in a bill of material are required to produce a given quantity of the parent item or product represented by the bill. For example, if 500 of product A are required and A is composed of two Bs, three Cs, one D, and four Es, the explosion determines that 1000 Bs, 1500 Cs, 500 Ds, and 2000 Es are needed.

extended quantity. In MPSP, the quantity of a component needed to complete a standard lot or standard batch of the end item. The system uses extended quantities to calculate resource usage in generated resource profiles.

extraction. A method of gathering current demand information for planning orders, which occurs as part of master schedule generation.

FALT. See final assembly lead time.

family. See production family.

family base plan. A family operating plan recorded to serve as a fixed point of reference. The base plan shows the intended production, demand, and inventory goals for the family. As family operating plans change, the base plan supports a historical comparison of actual performance with intended performance. See also family operating plan.

family operating plan. The production, sales, and inventory levels that the company expects to achieve for a production family. After each aggregation, which totals current demand and inventory information to the family level, the family operating plan may require adjustment to match changes in demand. The family operating plan is the basis for the item production plans of all items assigned to that family.

feature. The options of an end item are grouped by feature. A feature can only have end items as parents and options as components. An end item can have multiple features, and a feature usually has multiple options.

final assembly lead time (FALT). The time required to produce an end item from the next lower level of components.

finished goods. Items ready for shipment to a customer, including parts reserved for service.

firm planned order. An order, originally created by MPSP or MRP, whose date and quantity have been fixed by a planner, but for which no paperwork authorizing production has been released and no components have been allocated.

fixed order quantity. A rule for determining order size that assigns a fixed quantity to all planned orders.

forecast. An estimate of customer (independent) demand for an item for a specific period in the future.

forecast quantity. The quantity of the item used in the forecast.

generated requirement. A requirement for a component generated because of a requirement existing for this component's parent (dependent demand).

generation. (1) In MRP, the process of exploding every requirement down through the bills of material and creating planned orders for needed components parts as necessary. (2) In MPSP, the process of planning orders to meet demand for a master schedule item. Also, the process of calculating resource profiles.

held inventory. In production planning, that portion of on-hand or projected inventory that is reserved for future planned shipments. Held inventory provides a way to smooth production by reserving production in one period for shipment in a later period.

held requirement. A requirement that has been designated by the planner to be retained by MRP even though it may be past due. It is held until the start date.

historical standard cost. A base standard cost that usually remains constant for twelve months and is used to measure cost changes.

inquiry. (1) A request for information in storage. (2) A request for information that puts the system into inquiry mode.

inspection. The examining of completed production or purchased items to see that parts meet tolerances and that work has been properly completed. It may or may not be a separate operation.

interface. (1) The hardware and programs that permit exchange of information between computer systems or among devices. (2) The facility to allow information to pass from one application to another.

intersite order. A planned or open order for an item from a requesting warehouse to a supplying warehouse, in the InterSite Logistics (ISL/MISL) application. MPSP and MRP in the supplying warehouse use as demand the requirements from planned intersite orders from MRP in the requesting warehouse. When an intersite order is released (converted from planned to open), a customer order for it is created in the supplying warehouse, and MPSP and MRP treat it in planning just as they do other customer orders.

issue. The amount of inventory released for production or sale.

item. Any raw material, manufactured or purchased part, or assembly.

item adjustment. In production planning, the changes that a planner makes to item production rates in one or more periods to smooth production rates by setting the production quantities higher or lower than the demand shown for those periods. Positive adjustments increase held inventory for the item; negative adjustments decrease held inventory.

item data. Data describing products, the component parts and raw materials from which they are made, the bill of material, and the routing indicating the manufacturing process.

item process. An item process is made up of an item revision plus a routing and a bill of material. Items are not required to have item processes. An item without a bill or routing would not have a process. Thus, an item process is an engineering record that defines a site-item-revision bill of material and routing over a specific period of time. Item processes can be primary or alternate.

item production plan. The quantities of an item to be produced in each period. This set of quantities defines the demand for production planned items in master schedule planning. The system plans orders to meet these period quantities. The item production plan begins as an item trial plan.

item revision. An item revision helps identify differences in how items evolve through their manufacturing process as brought about by engineering change. The three essential properties of an item are form, fit, and function. Form is the configuration of an item, such as shape, size, weight, or other physical properties that identify the item. Fit is the characteristic that allows an item to connect to or become a part of another item. Function is the use or performance of an item. Engineering changes (EC) drive the creation of revisions for an item. When the EC affects the form, fit, or function of an item, a revision cannot be created. All other changes can result in a revision, usually identified by a letter of alphabet A through Z.

item trial plan. The net blended demand for an item by period, plus any item adjustments for each period. Aggregation updates the net blended demand, sometimes requiring further adjustments. The item trial plan has no effect on master scheduling for the item until the trial plan is accepted as the item production plan.

JIT. See just-in-time.

job. (1) A unit of work for a computer; for example, a payroll job. (2) One or more related procedures or programs grouped into a first level procedure. See also procedure level.

job queue. A list of jobs waiting to be processed by the system.

just-in-time (JIT). The company-wide effort to improve product quality, reduce cycle times, eliminate waste in production and business processes, and manage a timely flow of inventory and production.

key. The character or characters in a data record that identify the record and establish its order with respect to other records.

lead time. (1) The number of days, weeks, or months needed to place an order, process it, and receive the material into inventory. (2) An estimate of the time required in the shop from order release to availability.

lead time adjustment. See component lead time adjustment.

level. A relative point in the assembly process where components are added. Levels help describe assembly dependencies. A level 0 assembly is shipped to the customer. Raw material is the lowest level (highest level number) in a company's bill structure.

load. (1) To enter data or programs into storage; for example, to load a master file. (2) The amount of capacity requirements for manufacturing facilities (usually by time period) based on the master production schedule, the material requirements plan, and standard operating times.

loading. The procedure for determining capacity requirements for manufacturing facilities based on the master production schedule.

lot size. The quantity of an item normally produced in one manufacturing run. Contrast with standard batch quantity.

lot sizing. The procedure for determining the planned order quantities from a schedule of net requirements.

manufacturing order. (1) An order issued to the factory to produce a component or assembly. (2) A number that identifies a manufacturing or shop order.

manufacturing resource planning (MRP II). An integrated approach linking planning, execution, and feedback activities of a company's financial and production organizations in order to meet overall company objectives. Material Requirements Planning (MRP) is one area of MRP II.

master level item (MLI). Items that you want to control planning for in MRP. Master level items are usually end items, expensive components, and service parts. When MPSP is installed and interfacing, most MLI items are master scheduled items and are controlled in MPSP.

master production schedule. For a selected item (master scheduled item), a list of what the company wants to build, expressed as time-phased orders. MPSP produces a master production schedule for each master scheduled item, based on the type of demand specified for that item. The master production schedule is not a statement of demand; it is a set of specific orders, with due dates and quantities. The master production schedules provide the input for MRP, which plans orders for the components needed to meet the master production schedules.

master production schedule planning (MPSP). An application that helps you plan long-range production at the family and end item level, convert the long range goals into specific orders by period, and assess your resource needs to support production. Master production schedule planning results in a set of orders that take into account long-term goals and current capacity and other resource constraints. It minimizes the need for changes in MRP.

master schedule planning. The set of activities that generates and maintains master production schedules using specified demand sources. It is a part of master production schedule planning (MPSP).

master scheduled item (MSI). An important item (usually an end item or a major service part) whose production you want to control using a master production schedule. A master scheduled item is controlled in MPSP; a master level item (MLI) is controlled in MRP. If an item is both master scheduled and MLI, the master scheduled status takes precedence.

MLI. See master level item.

MRP II. See manufacturing resource planning.

net change planning. A planning run that replans only those items that have had activity since the last planning run.

number of forecast periods. The number of periods to be used in the forecast for this item.

offset. (1) To schedule lower level components to be completed at the time they are needed in production. (2) In MPSP, the number of days before a parent item is completed that a component must be available. Profile generation calculates offsets from the component to the final end item.

on-hand. (1) Pertaining to stock that is immediately available for shipment. See also available. (2) Pertaining to items available in the stockroom. Stock now on the receiving dock or issued to the shop floor is not considered on-hand stock.

on-order. Pertaining to stock that has been requested but has not been received.

open order. See released order.

operation. A manufacturing or assembly procedure performed on an item. A routing defines the sequence of several operations.

operation sequence number. A number assigned to an operation that defines the sequence within a routing.

option. An option is an item that is one of many items directly related to a feature. An end item can have many options and similar options are categorized in groups called features. For example, the option red could be included under the feature color.

order. (1) A request from a customer for goods to be delivered or services to be performed. (2) An authorization to purchase or manufacture.

order due date. The date the order is scheduled to be completed.

order point. A quantity that is the sum of forecast demand through replenishment lead time plus safety stock.

order policy code. A code that selects from a menu of lot sizing techniques, such as discrete, fixed order quantity, order up to quantity, and part period balancing.

order quantity. A quantity to be ordered when issuing a replenishment order. See also lot sizing.

order release. (1) In order processing, authorization to fill a customer's order. (2) In manufacturing, authorization to assemble or fabricate a product identified by a shop order. (3) In MRP, authorization to purchase or manufacture an item.

order start date. The date the order is scheduled to be started.

part-period balancing (PPB). A lot sizing technique very similar to EOQ. It attempts to minimize the sum of the cost of carrying inventory and the cost of acquiring inventory. PPB differs from EOQ in that it uses the current net requirements schedule, rather than a historical usage figure, in performing the calculation to minimize costs.

pending change. A change made to an open order in MPSP. MPSP calculations honor the change; but other applications do not have access to the change until it is made to the order itself using Inventory Management (IM) or a similar application.

planned order. An order that is generated by MPSP or MRP when the available balance for an item is insufficient to meet its gross requirements at the time the requirements are due. A planned order is not committed to the vendor or shop floor until it is released.

planner. An individual with the authority and the responsibility for control of the production planning and purchase planning for a set of inventory items.

planning run. The computer activity of aligning orders and resources to meet external demand.

planning source. The specified type of demand that master schedule planning uses to generate the master production schedule for an item. Possible planning sources are forecasts only, customer orders only, blended demand, production plans, or manually entered firm planned orders.

planning warehouse. MPSP and MRP plan for the items in the warehouses designated as planning warehouses.

product structure. A technique for organizing bills of material on a computing system.

production control. The functional area of the business responsible for the day-to-day scheduling of plant floor resources. Shop order release, expediting, and order tracking are the primary responsibilities of this area.

production family. A group of master scheduled end items with similar resource needs. Aggregation combines the production, demand, and inventory information for the items (family members) to get information for the family. Production planning sets production goals for the family, which you then distribute among the member items. Resource requirements planning checks the resources needed to meet the family-level production goals.

production plan. See item production plan.

production planning. The set of activities that translates long-range business and production goals into family-level production targets by period, and then into item production plans for the items in the families. The item production plans define demand for the master schedules of items with a planning source of production plans. Production planning is part of master production schedule planning (MPSP).

production target. The desired level of production that management wants to achieve for a family for one period. The production targets are the basis for the family operating plan.

propagated forecast. A straight-line forecast automatically created by MRP's planning run using information in the Planning Information file.

propagated requirement. Straight-line external requirements automatically created by MRP's planning run using information in the Planning Information file.

purchase order. A document sent to a vendor requesting goods or services.

quantity significance. A method used in production planning to reduce the number of digits that appear in the quantity fields on displays and reports. You can use quantity significance if your production planning involves very large quantities.

questionnaire. The installation questions that you answer to adapt an application to your company and its needs.

queue. (1) A waiting line or list formed by items in a computer system waiting for service; for example, jobs to be performed. (2) To arrange in or form a queue. (3) In manufacturing planning systems, the backlog of work waiting to be processed at a work center.

quoted lead time. The elapsed time (from point of order to receipt at the receiving dock) the vendor quotes for delivery.

receipts. (1) Merchandise or stock that is received in inventory. (2) Cash received. See also expected receipts.

release. (1) To authorize and commit orders by changing a planned order into a purchase order or shop order. (2) To specify a date and quantity to be shipped under a blanket order. (3) To enter an unplanned order as a purchase or shop order.

released order. An order that is in the process of being issued or has already been issued to the shop floor or a vendor. Once issued, it is a commitment that can be canceled or rescheduled only through negotiation. It is identified by the order number.

requirement. In MRP, your statement saying that you need a specific quantity of a master level item by a particular date on your master level item schedule.

requisition. An authorization to purchase materials or release quantities of items from stock.

resource planning. The set of activities that help you assess your resource needs for meeting your family-level production goals (resource requirements planning) and your master production schedules (rough-cut capacity planning). Resource planning is a part of master production schedule planning (MPSP).

resource profile. A set of records that defines the critical resources an item requires, when it uses that resource in relation to its end date, and how much it uses per standard lot size or standard batch quantity. MPSP uses resource profiles to calculate resource needs for meeting family-level production plans and master production schedules.

resource requirements planning. The process of identifying the critical resources needed to meet family-level long-range production goals and ensuring that the resources are available when they are needed. Resource requirements planning may cause you to adjust production goals and change the availability of a resource.

revision. See item revision.

rough-cut capacity planning. The process of identifying the resources needed to meet the master production schedules and ensuring that the resources are available when they are needed. Rough-cut capacity planning may cause you to adjust the production schedules or change the availability of a resource.

routing. A list describing the sequence of operations required to make an item.

runtime. The elapsed time an item is actually being worked on in a machine center. It is calculated, at standard, by multiplying order size by time per piece.

safety stock. The quantity of an item carried in excess of expected demand to meet unexpected increases in demand.

sales analysis. The statistical accumulation of data regarding the sale of goods made by a company in various classifications and categories.

scheduled receipt. See released order.

session. The period of time during which a user of a terminal can communicate with an interactive system, usually elapsed time between logon and logoff.

setup. The procedure (costs) associated with getting a production facility (machine) ready to produce a new item. The procedure is not dependent on the number of items to be produced. For the sake of simplicity, the costs of removing the setup (teardown) are usually included.

shrinkage factor. A percentage used to increase the quantity on a planned or released shop order to allow for scrap. An alternate method is to use it to increase gross requirements.

site. Defines a grouping of engineering records. A site can take several forms. Examples of a site are: central engineering site serving multiple warehouses or plants, single engineering site assigned to a single warehouse or plant, simulation site for developing new product costs. Item Master, product structure, production facility, and routing records are keyed by site.

S-number. The S-number has a field length of 20 and is only seen if features and options were selected in PDM or EPDM. One option number for each feature for a specific end item can be entered in the S-number. The option numbers in the S-number correspond by location to the field size template established when the PDM/EPDM questionnaire was answered.

standard batch quantity. The amount of this item that the system uses to calculate the required quantities for components. The quantity can represent the normal output or a production goal. It can also serve as a multiplier to reduce the level of precision required for components that are used in very small quantities relative to one unit of the end item.

standard cost. See historical standard cost.

start date. The date work is to begin on an order. This is when materials are picked and delivered to the first work center.

system date. The date assigned by the system operator during initial program load. Generally, the system date is the same as the actual date. See also session date.

time fence. A policy or guideline established to note where various restrictions or changes in operating procedures take place. For example, changes to the master production schedule can occur easily beyond the CMLT (cumulative material lead time) Time Fence, whereas changes inside the CMLT Time Fence become increasingly more difficult, to a point where changes become inadvisable. Time fences can define the points. See also CMLT Time Fence and Demand Time Fence.

time periods of supply. A lot-sizing technique to plan an order to cover requirements for a fixed number of days.

time-phased allocations. Future allocations assigned on the date when they are needed instead of on the current date (immediate allocations). Both MPSP and MRP can use future allocations in planning orders.

unit of measure. A code indicating the measurement basis for inventory, such as each, pound, tons, gallons, feet.

unit price. The price per standard unit of a product or service.

update. To modify a file with current information according to a specified procedure.

user ID. A special value assigned to an operator and typed in when the operator signs on. The system uses the value to determine whether the operator is authorized to use the system or requested function.

vendor. A seller of goods or services.

warehouse stock location. The identification of the physical location of an item within inventory storage.

work center. A facility, normally a group of machines having similar characteristics, used to perform a manufacturing process; for example, an assembly area or milling machine center.

Index

A

- activity sequence
 - installing and using MPSP **D-1**
 - MPS planning and MRP planning 2-32
- add
 - a record to the Resource Master file 5-6
 - a resource to a resource profile 5-31, 5-32
 - firm planned order to master schedule 4-27
 - one or more master scheduled end items to a production family 3-83, 3-86
- adjusted quantity per (QPACY)
 - used in calculating extended quantity 2-102
- administrative lead time (LTADM)
 - included in offset 2-87
 - used in calculating item's lead time 2-82
- Aggregate to Production Families
 - (Confirm) display-AMV3A0 3-7
 - display-AMV3HL 3-5
- aggregate to production families 3-2
- Aggregation Error List (AML340) 2-13
 - calculations and actions, list of additional 2-12
 - completed before resource profile generation 2-79
 - consuming item production plan and item blended demand 2-14
 - definition 2-6
 - effect on demand percentages for family items 2-98
 - evaluating family totals 2-16
 - preparing for 2-6
 - process overview 2-8
 - regular use improves planning accuracy **A-3**
 - when to aggregate 2-7
- aggregated
 - family information, basis for plans 2-16
 - item production plans compared with family operating plan 2-24
 - item production plans compared with master schedules 2-24
 - master schedules compared with family targets 2-24
 - plans compared with aggregated master production schedules 2-24
- AML180—Test Master Schedule Resources display 4-49
- AML201—Display/Maintain Family Operating Plans Selection display 3-9
- AML202—Display/Maintain Family Operating Plans display 3-12
- AML203—Family Operating Plan Detail display 3-18
- AML204—Daily Rates display 3-22
- AML211—Replace Family Base Plans Selection display 3-52
- AML221—Replace Family Base Plans Error List, description 8-25
- AML230—Display/Maintain Item Trial Plans Family Selection display 3-41
- AML231—Display/Maintain Item Trial Plans Item Selection display 3-43
- AML232—Display/Maintain Item Trial Plans display 3-45
- AML240—Replace Item Production Plans Family Selection display 3-55
- AML250—Replace Item Production Plans Error List description 8-26
- AML261—Family Operating Plan Report Options display 3-81
- AML271—Family Operating Plan Report
 - description 8-4
 - display 3-81
 - using 2-26
- AML280—Family Plan Inquiries Selection display 3-58
- AML281—Base Plan Inquiry display 3-61
- AML282—Base Plan Inquiry Production Plan display 3-65

AML283–Base Plan Inquiry Demand Plan display 3-69
 AML284–Base Plan Inquiry Inventory Plan display 3-73
 AML285–Operating Production Targets vs Aggregated Plans display 3-77
 AML321–Item Resource Report 5-40
 AML340–Aggregation Error List
 description 8-3
 printed after aggregation 2-13
 AML360–Display/Maintain Production Families Selection display 3-84
 AML361–Display/Maintain Production Families display 3-86
 AML410–Generate Master Schedules Planning Run Options display 4-7
 AML411–Generate Master Schedules Planning Run
 Status display 4-11
 Submit display-AML413 4-13
 AML450–Display/Maintain Master Schedule Planner/Family Selection display 4-15
 AML451–Display/Maintain Master Schedule Item Selection display 4-21
 AML452–Display/Maintain Master Schedule
 Production Plan display 4-23
 Production Plan–Schedule Controlled Item display 4-35
 AML453–Display/Maintain Master Schedule display 4-37
 AML454–Blended Demand display 4-42
 AML455–Master Schedule Open Order Maintenance List, description 8-10
 AML45F–Display/Maintain Master Schedule Family Selection display 4-19
 AML45P–Display/Maintain Master Schedule Planner Selection display 4-17
 AML460–Master Schedule Planning Report Options display 4-61
 AML480–Planning Run Status Report, description 8-23
 AML490–Available to Promise Item Selection display 4-64
 AML501–Generate Resource Profiles Selection display 5-20
 AML502–Generate Resource Profiles Family Selection display 5-24
 AML503–Generate Resource Profiles Item Selection display 5-27
 AML508–Resource Profile Generation Submit display 5-30
 AML511–Display/Maintain Resource Profiles Selection display 5-32
 AML512–Display/Maintain Resource Profiles display 5-34
 AML531–Resource Requirements Selection display 3-32, 4-51
 AML532–Resource Requirements Analysis display 3-35, 4-53
 AML533–Resource Requirements Detail display 3-38, 4-56
 AML541–Test Family Operating Plan Resources Selection display 3-29
 AML559–Resource Profile Exception Report
 description 8-30
 prints batch or lot sizes 2-102
 prints lead times 2-101
 used in resource planning 2-78
 AML591–Resource Master File Maintenance (Select) display 5-4
 AML592–Resource Master File Maintenance (Add) display 5-6
 AML593–Resource Master File Maintenance (Change) display 5-8
 AML594–Resource Master File Maintenance (Delete) display 5-10
 AML595–Resource Master File Maintenance (Status) display 5-12
 AML599–Resource Master File Maintenance Error List, description 8-29
 AML601–Change/Display Horizon Dates display 7-3
 AMLM10–Production Planning menu
 options of 3-2
 AMLM20–Master Schedule Planning menu
 options of 4-2
 AMLM30–Resource Profile Management menu 5-3
 options of 5-1
 AMM171–Item Detail Information display-Lead time factors 4-87
 AMM172–Item Detail Information display-Order/Schedule sizing factors 4-89
 AMM173–Item Detail Information display-Inventory status summary 4-92
 AMM174–Item Detail Information display-Item characteristics 4-94

AMM175-Item Detail Information display-Requirements management factors 4-98
 AMM176-Item Detail Information display-Master scheduling factors 4-102
 AMM510-Item Requirements Inquiry-Select a planner's items display 4-73
 AMM511-Item Requirements Inquiry-Item overview display 4-76
 AMM512-Item Requirements Inquiry-Peg To display 4-82
 AMM516-Item Requirements Inquiry-Select a planner's items display 4-85
 AMV36F-Change/Display Horizon Dates display 7-2
 AMV3A0-Aggregate to Production Families (Confirm) display 3-7
 AMV3A1-Item Resource Report Options display 5-43
 AMV3HH-Generate Master Schedules display 4-5
 AMV3HI-Generate Resource Profiles display 5-18
 AMV3HJ-Resource Master File List display 5-15
 AMV3HK-Master Schedule Planning Report display 4-59
 AMV3HL-Aggregate to Production Families display 3-5
 AMV3HM-Item Resource Report Options display 5-41
 AMV3HQ-Test Master Schedule Resources display 4-47
 AMV3HR-Test Family Operating Plan Resources display 3-27
 AMVATP03-Display Available to Promise display 4-66
 AMVATP05-Display Available to Promise display 4-69
 application
 interfaces to MPSP 1-15
 application tailoring 1-22, 1-31
 arrays
 array anchor date in Calendar date records C-6
 backlog, loading in the Demand Interface file C-12
 date changes in WKYDM array C-9
 demand arrays C-5
 demand for production planning C-5
 in the Demand Interface file C-5
 WKYDM array C-7
 YR1DM array C-5, C-7
 YR2DM array C-5, C-7
 availability
 inventory, calculating 4-78
 available to promise (ATP)
 definition 2-108
 demand and supply quantities 2-109
 features and calculations 2-108
 from Master Schedule Planning menu (AMLM20) 4-64
 horizon 2-108
 how calculated in MPSP 2-110
 negative quantities 2-113
 Available to Promise Item Selection display-AML490 4-64

B

base plan date 7-1, 7-3
 Base Plan file
 description 1-24
 updated by RCPLB and SALBF during aggregation 2-15
 Base Plan Inquiry Demand Plan display-AML283 3-69
 Base Plan Inquiry display-AML281 3-61
 Base Plan Inquiry Inventory Plan display-AML284 3-73
 Base Plan Inquiry Production Plan display-AML282 3-65
 base plans, family 3-52
 batch lot size
 correcting 2-102
 printed on Resource Profile Exception Report (AML559) 2-102

- beginning day of scheduling week
 - relation to production planning periods 2-30
 - set in Questionnaire 2-30
- bibliography iii
- bill of material
 - exploded for resource profile 2-84, 2-86
 - used in generating resource profiles 2-77
- blended demand 4-32, 4-42
 - aggregated to family level 2-16
- Blended Demand display–AML454 4-42
- business plan
 - meeting projected revenue 2-17
 - MPSP's role 1-1
 - semi-annual and yearly business plan cycle 1-3
- business processes
 - monthly performance measurement and the operating plan revision cycle 1-6
 - summary production plans and the business cycle 1-8
 - weekly/daily master production scheduling cycle 1-7
 - yearly and semi-annual business plan cycle 1-3

C

- calculating
 - extended quantity 2-96
 - offsets 2-87
 - resource values 2-98
- calculations
 - additional ones in aggregation 2-12
 - available to promise 2-110
 - available to promise quantities 2-113
 - cumulative check 2-17
 - extended quantity 2-96
 - item trial plan 2-21
 - item's percent of contribution to family 2-13
 - lead time deviation percent 2-101
 - list of for each family during aggregation 2-8
 - offset for a work center 2-89
 - Prod Plan Build \pm 2-21
 - projected ending inventory (ATP) 2-111
 - projected inventory (family level) 2-17
 - resource value 2-98
 - understanding, in MPSP 2-1
 - variances and variance percentages (family inquiries) 2-24
 - weighted cost per family item (aggregation) 2-12
 - work center capacity 2-96
- Calendar date records
 - anchor date for arrays in Demand Interface file C-6
 - date records for Demand Interface file C-6
 - Work With Calendars option (IM and MRP) C-6
- Calendar file
 - description 1-26
- Capacity Requirements Planning application (CRP)
 - role in MPSP business plan 1-4
- change
 - a record in the Resource Master file 5-8
 - a resource in a resource profile 5-31, 5-32
 - horizon dates 7-1, 7-3
 - master schedules 4-15

- production targets 3-9, 3-12
- the production rate per day for a family 3-83, 3-86
- the quantity significance level for a family 3-83, 3-86
- Change/Display Horizon Dates display-AML601 7-3
- Change/Display Horizon Dates display-AMV36F 7-2
- changing
 - item held inventory 2-22
- CMLT
 - stable production plans in aggregation 2-8
- CMLT (cumulative material lead time) 4-44
- CMLT Time Fence 4-32, 4-44
 - relation to master scheduling horizon 2-71
 - relation to planning zones 2-71
- codes
 - order policy 4-90
- comparing
 - family base plan with actual performance 2-24
 - family base plan with family operating plan 2-24
 - operating production targets vs aggregated plans 2-24
- composite lot size
 - used for family resource profile 2-86
- concurrent file maintenance 1-22
- conflicting activities
 - effect on master scheduling 2-62
 - none before master production schedule generation 2-35
- consuming
 - forecasts (CRPLB and CRPLA) 2-72
 - item blended demand (SALBF, SALAF) 2-14
 - item production plans (RCPLB, RCPLA) 2-14
- costs
 - for item resource 2-102
 - for work center resource 2-102
- costs/units , weighted cost per family item 2-12
- create a resource profile, not generated 5-31, 5-32
- creating , Demand Interface file C-11
- critical resource
 - grouped by resource conversion factor 2-99
 - Resource Number field B-1, B-2
- CRPLB, CRPLA
 - examples of use 2-72
 - reduce forecasts in master scheduling 2-41
 - relation to Demand Time Fence 2-72
 - relation to MPS Current Date 2-72
 - updated by IM 2-72
 - used to consume forecasts in master scheduling 2-72
- Cumulative Check
 - calculations 2-17
 - negative quantities 2-17
 - relation to family targets 2-17
- Cumulative Material Lead Time (CMLT) Time Fence 4-44
- current demand, extract 4-9
- Current Status file
 - description 1-24
 - used in aggregation 2-13
- Customer Order Detail file, description 1-26
- Customer Order Management application (COM) , interface with MPSP 1-16
- customer orders
 - available from Demand Interface file C-4

- in Demand Interface file C-10
- independent demand 2-43
- releasing per customer order (requires COM) 2-69
- cutoff date 4-8, 7-1, 7-3

D

- Daily Rates display-AML204 3-22

- data entry

- methods 1-22

- part of application's design 1-22

- defining

- horizon before master production schedule generation 2-35

- master scheduled items 2-36

- delete

- a record from the resource master file 5-10

- one or all resources in a resource profile 5-31, 5-32

- one or more master scheduled end items from a production family 3-83, 3-86

- demand

- assembled for planning orders 2-58

- calculated in available to promise 2-109

- current, for planning orders (extraction) 2-46

- dependent 2-44

- extraction for master scheduling 2-46

- how to load in Demand Interface file C-12

- in available to promise 2-109

- independent 2-41

- overdue 2-61

- type determined by Planning Source code field B-1, B-2

- types contained in Demand Interface file C-1

- types used in master scheduling 2-41

- updated for master production schedule generation 2-35

- demand file date 4-8, 7-1, 7-3

- Demand Interface file

- anchor date for arrays set in Calendar date records C-6

- arrays, demand C-5

- Calendar date records C-6

- conditions when needed C-4

- creating the file C-11, C-12

- customer backlog C-10

- customer backlog, loading C-12

- demand arrays C-5

- Demand File Date (FDPDT) C-6

- description 1-24, C-1

- detailed information in Appendix C C-1

- file layout C-2

- forecasts converted to weekly forecasts C-7

- forecasts, loading C-12

- how FCST uses the file C-5

- how MPSP uses the file C-4

- how to create with FCST installed and interfacing C-11

- how to create without FCST installed and interfacing C-11

- reloaded regularly to stay current A-3

- types of demand contained C-1

- updating the file C-13

- use in master scheduling C-4

- use in production planning C-4

- user loads backlog if COM not installed and interfacing C-4

- user loads forecasts if FCST not installed and interfacing C-4
- weekly forecasts in the first year C-7
- WKYDM weekly array dates C-7, C-9
- YR1DM and YR2DM array dates C-7
- Demand Management menu options
 - 4—Item Requirements Inquiry—Select Item 4-71
- demand source 4-38
- Demand Time Fence 4-32, 4-44
 - effect on demand calculations 2-69
 - field (DMDFN) used by MPSP to create Demand Time Fence B-1
 - relation to FALT 2-69
 - relation to master scheduling horizon 2-71
 - relation to planning zones 2-69, 2-71
- Demand Type Code (DMTYP)
 - identifies type of demand in arrays C-2
 - special range for option backlog C-10
- dependent demand 4-40
 - option forecasts 2-45
 - used for master scheduling 2-44
- display
 - master schedules, item selection 4-21
 - master schedules, production planned items 4-23
 - master schedules, production planned, schedule controlled items 4-35
- Display Available to Promise display—AMVATP03 4-66
- Display Available to Promise display—AMVATP05 4-69
- display resource requirements , for family operating plans 3-32, 4-51
- Display/Maintain Family Operating Plans display—AML202 3-12
- Display/Maintain Family Operating Plans Selection display—AML201 3-9
- Display/Maintain Item Trial Plans display—AML232 3-45
- Display/Maintain Item Trial Plans Family Selection display—AML230 3-41
- Display/Maintain Item Trial Plans Item Selection display—AML231 3-43
- Display/Maintain Master Schedule display—AML453 4-37
- Display/Maintain Master Schedule Family Selection display—AML45F 4-19
- Display/Maintain Master Schedule Item Selection display—AML451 4-21
- Display/Maintain Master Schedule Planner Selection display—AML45P 4-17
- Display/Maintain Master Schedule Planner/Family Selection display—AML450 4-15
- Display/Maintain Master Schedule—Production Plan display—AML452 4-23
- Display/Maintain Master Schedule—Production Plan display—Schedule Controlled Item—AML452 4-35
- Display/Maintain Production Families display—AML361 3-86
- Display/Maintain Production Families Selection display—AML360 3-84
- Display/Maintain Resource Profiles display—AML512 5-34
- Display/Maintain Resource Profiles Selection display—AML511 5-32
- displays
 - Aggregate to Production Families (Confirm)—AMV3A0 3-7
 - Aggregate to Prooduction Families—AMV3HL 3-5
 - Available to Promise Item Selection—AML490 4-64
 - Base Plan Inquiry Demand Plan—AML283 3-69
 - Base Plan Inquiry Inventory Plan—AML284 3-73
 - Base Plan Inquiry Production Plan—AML282 3-65
 - Base Plan Inquiry—AML281 3-61
 - Blended Demand—AML454 4-42
 - Change/Display Horizon Dates—AML601 7-3
 - Change/Display Horizon Dates—AMV36F 7-2
 - Daily Rates—AML204 3-22
 - Display Available to Promise—AMVATP03 4-66
 - Display Available to Promise—AMVATP05 4-69
 - Display/Maintain Family Operating Plans Selection display—AML201 3-9

Display/Maintain Family Operating Plans-AML202 3-12
 Display/Maintain Item Trial Plans Family Selection-AML230 3-41
 Display/Maintain Item Trial Plans Item Selection-AML231 3-43
 Display/Maintain Item Trial Plans-AML232 3-45
 Display/Maintain Master Schedule Family Selection-AML45F 4-19
 Display/Maintain Master Schedule Item Selection-AML451 4-21
 Display/Maintain Master Schedule Planner Selection-AML45P 4-17
 Display/Maintain Master Schedule Planner/Family Selection-AML450 4-15
 Display/Maintain Master Schedule-AML453 4-37
 Display/Maintain Master Schedule—Production Plan-AML452 4-23
 Display/Maintain Master Schedule—Production Plan—Schedule Controlled
 Item-AML452 4-35
 Display/Maintain Production Families Selection-AML360 3-84
 Display/Maintain Production Families-AML361 3-86
 Display/Maintain Resource Profiles Selection-AML511 5-32
 Display/Maintain Resource Profiles-AML512 5-34
 Family Operating Plan Detail-AML203 3-18
 Family Operating Plan Report Options-AML261 3-81
 Family Plan Inquiries Selection-AML280 3-58
 Generate Master Schedules Planning Run Options-AML410 4-7
 Generate Master Schedules Planning Run Status-AML411 4-11
 Generate Master Schedules Planning Run Submit-AML413 4-13
 Generate Master Schedules-AMV3HH 4-5
 Generate Resource Profiles Family Selection-AML502 5-24
 Generate Resource Profiles Item Selection-AML503 5-27
 Generate Resource Profiles Selection-AML501 5-20
 Generate Resource Profiles-AMV3HI 5-18
 Item Detail Information-Inventory status summary-AMM173 4-92
 Item Detail Information-Item characteristics-AMM174 4-94
 Item Detail Information-Lead time factors-AMM171 4-87
 Item Detail Information-Master scheduling factors-AMM176 4-102
 Item Detail Information-Order/Schedule sizing factors-AMM172 4-89
 Item Detail Information-Requirements management factors-AMM175 4-98
 Item Requirements Inquiry-Peg To-AMM512 4-82
 Item Requirements Inquiry-Select a planner's items-AMM510 4-73
 Item Requirements Inquiry-Select a planner's items-AMM516 4-85
 Item Resource Report Options-AMV3A1 5-43
 Item Resource Report Options-AMV3HM 5-41
 Master Schedule Planning Report Options-AML460 4-61
 Master Schedule Planning Report-AMV3HK 4-59
 Operating Production Targets vs Aggregated Plans-AML285 3-77
 Replace Family Base Plans Selection-AML211 3-52
 Replace Item Production Plans Family Selection-AML240 3-55
 Resource Master File List-AMV3HJ 5-15
 Resource Master File Maintenance (Add)-AML592 5-6
 Resource Master File Maintenance (Change)-AML593 5-8
 Resource Master File Maintenance (Delete)-AML594 5-10
 Resource Master File Maintenance (Select)-AML591 5-4
 Resource Master File Maintenance (Status)-AML595 5-12
 Resource Profile Generation Submit -AML413Re 5-30
 Resource Requirements Analysis-AML532 3-35, 4-53
 Resource Requirements Detail-AML533 3-38, 4-56
 Resource Requirements Selection-AML531 3-32, 4-51
 Test Family Operating Plan Resources Selection-AML541 3-29
 Test Family Operating Plan Resources-AMV3HR 3-27
 Test Master Schedule Resources-AML180 4-49
 Test Master Schedule Resources-AMV3HQ 4-47
 due dates

- firm planned orders 2-61
- forecasts and customer backlog 2-46
- option backlog 2-48
- production planned demand 2-33

E

- effective date of profile
 - effect on family resource profile 2-87
- Enabling MPSP to EPDM 1-19
- Enterprise Product Data Management application (EPDM)
 - interface with MPSP 1-15
- EPDM files used by MPSP 1-29
- EPDM, working with MPSP 1-19
- evaluating
 - aggregated family totals 2-16
 - base plan vs actual performance 2-24
 - base plan vs operating plan 2-24
 - family production plans 2-23
 - operating production targets vs aggregated plans 2-24
 - production targets 2-19
- eWorkPlace—graphical user interface for MAPICS XA 1-31
- exception codes 4-31
 - explanations 2-65
 - for maintaining master schedule orders 2-63
 - list 2-65
 - MPSP codes in MRP 2-68
 - priority of codes 2-68
 - resolved in MPSP 2-68
- exception conditions—master schedule
 - can include recommended dates 2-63
 - codes 2-65
 - sources of information A-4
- explicit inquiry 4-85
- extended quantity
 - calculations 2-96
- extract current demand 4-9
- extraction
 - definition 2-46
 - dependent demand 2-48
 - relation to planning source code 2-47
- extraction date, last 4-9

F

- factor, shrinkage 4-90
- family base plan
 - compared with actual information 2-24
 - compared with operating plan 2-24
 - evaluating 2-23
 - historical reference point 2-4
 - performance measurement tool 2-4
 - relation to other production plans 2-4
- family base plans, replace 3-52
- family operating plan 3-9, 3-12
 - compared with family base plan 2-24
 - development 2-4
 - evaluating 2-23
 - relation to other production plans 2-4

- set up before resource profile generation 2-75
- Family Operating Plan Detail display-AML203 3-18
- Family Operating Plan Report display-AML271 3-81
- Family Operating Plan Report Options display-AML261 3-81
- family plan inquiries 3-58
- Family Plan Inquiries Selection display-AML280 3-58
- Family Production Plan file
 - description 1-24
 - used in aggregation 2-12
- feature
 - basis for calculating option backlog 2-48
 - basis for calculating option forecasts 2-45
- field
 - codes 2-60
 - item 2-39
- fields
 - used by MPSP to support MPSP functions B-1
- file maintenance
 - concurrent 1-22
 - family operating plans (production targets) 3-9
 - item trial plans 3-41
 - master schedules 4-14, 4-15
 - master schedules, item selection 4-21
 - master schedules, production planned items 4-23
 - master schedules, production planned, schedule controlled items 4-35
 - methods 1-22
 - production families 3-83, 3-86
 - Resource Master file 5-4
 - resource profiles 5-31, 5-32
- files
 - concurrent use 1-22
 - file sharing 1-23
 - master 1-23
 - part of application's design 1-22
 - system control 1-24
 - types of 1-23
 - work 1-23
- final assembly lead time (FALT) , relation to Demand Time Fence 2-69
- firm planned order
 - adding 4-27
 - maintenance 2-64
- forecast
 - demand 4-44
 - requirements 4-76
- Forecast Activity Flag (FCACT) C-12
- Forecasting application (FCST)
 - interface with MPSP 1-16
 - use of Demand Interface file C-5
- forecasts
 - available from Demand Interface file C-5
 - consumed by current receipts 2-72
 - consumed by customer orders 2-41
 - how to load in Demand Interface file C-12
 - Master Level Item Code required 2-41
 - option forecasts 2-45
 - reduced by CRPLB, CRPLA 2-41
- Form MS-01-Resource Master file maintenance 9-2
- forms , sample form 9-1

- forward scheduling
 - stores resource usage records 2-82
 - used in calculating item's lead time 2-81
- future allocations 4-93

G

- General Master Schedules display-AMV3HH 4-5
- generate
 - master schedules 4-4, 4-7
 - resource profiles 5-17, 5-32
- Generate Master Schedules Planning Run Options display-AML410 4-7
- Generate Master Schedules Planning Run Status display-AML411 4-11
- Generate Master Schedules Planning Run Submit display-AML413 4-13
- Generate Resource Profiles display-AMV3HI 5-18
- Generate Resource Profiles Family Selection display-AML502 5-24
- Generate Resource Profiles Item Selection display-AML503 5-27
- Generate Resource Profiles Selection display-AML501 5-20
- generated demand
 - for option items 2-48
 - used for master scheduling 2-44
- generated requirements 4-82
- generating master schedules
 - conflicting activities 2-35, 2-62
 - demand information updated 2-35
 - Planning Source code field required B-1, B-2
 - preparations 2-34
 - process for planning orders 2-57
- generating resource profiles
 - calculating offsets 2-87
 - calculating work center offset 2-89
 - codes required for production family 2-86
 - data base updated 2-75
 - exploding the bill of material 2-84, 2-86
 - in preparation for resource testing 2-75
 - overview 2-77
 - when to generate 2-79
- graphical user interface for MAPICS XA—eWorkPlace 1-31

H

- held inventory
 - affected by item adjustments 2-13, 2-22
 - definition 2-22
- held requirements 4-76, 4-78
- horizon
 - definition 2-28
 - MPS horizon and MRP horizon 2-32
- horizon dates
 - for master production schedule generation (planning run) 4-7, 7-3
 - for production planning 7-3
- horizon dates, changing 7-1, 7-3
- how item requirements inquiry works 4-71
- how MPSP works with EPDM 1-19
- how MPSP works with ISL/MISL 1-20
- how to use item requirements inquiry 4-71

I

- independent demand
 - customer orders 2-43
 - extracted for master scheduling 2-46
 - used in master scheduling 2-41
- inquiry
 - family, variances and variance percentages 2-24
 - help in detecting problems A-5
 - list of, in MPSP 1-30, 1-31
- inquiry, types in MPSP
 - Available to Promise from the Master Schedule Planning menu (AMLM20) 4-64
 - display resource requirements 3-32, 4-51
 - family plans 3-58
- installation activities
 - application tailoring 1-22, 1-31
 - preinstallation D-2
- interactive resource testing (family operating plans) 3-29, 3-30
- interfaces
 - COM and MPSP 1-16
 - EPDM and MPSP 1-15
 - FCST and MPSP 1-16
 - IM and MPSP 1-15
 - ISL/MISL and MPSP 1-16
 - MRP and MPSP 1-15
 - optional for MPSP 1-15, 1-16
 - PDM and MPSP 1-15
 - required for MPSP 1-15
- InterSite Logistics application (ISL/MISL)
 - interface with MPSP 1-16
- Intersite Transfer Requirements file (XFRMST) 1-26
- inventory
 - include/exclude inventory 2-54
 - movement 2-53
- Inventory Management application (IM)
 - completes changes to open orders from MPSP 1-18
 - interface with MPSP 1-15
- ISL/MISL, working with MPSP 1-20
- item
 - detail 4-87
 - item override 2-52
 - requirements 4-71
- item adjustment
 - effect on held inventory 2-13, 2-22
 - part of item trial plan 2-5
 - relation to Family Build \pm 2-21
 - relation to family targets 2-21
- Item Balance file
 - description 1-26
 - used for tracking receipts, sales 2-14
 - used in aggregation 2-12
- Item Detail Information-Inventory status summary-AMM173 display 4-92
- Item Detail Information-Item characteristics-AMM174 display 4-94
- Item Detail Information-Lead time factors-AMM171 display 4-87
- Item Detail Information-Master scheduling factors-AMM176 display 4-102
- Item Detail Information-Order/Schedule sizing factors-AMM172 display 4-89
- Item Detail Information-Requirements management factors-AMM175 display 4-98
- Item Master file
 - description 1-27

- preparations for production planning 2-2
 - used in aggregation 2-12
 - item process 1-19
 - item production plan
 - composition 2-5
 - developing based on item trial plans 2-20
 - held stable within CMLT in aggregation 2-8
 - relation to other production plans 2-4
 - replacing 2-22
 - item production plan date (production plan file date) 7-1, 7-3
 - Item Production Plan file
 - deleted when replacing all plans 2-22
 - description 1-25
 - item production plans, replace 3-55
 - item requirements inquiry
 - how it works 4-71
 - Item Requirements Inquiry--AMM510 4-73
 - Item Requirements Inquiry--AMM516 4-85
 - Item Requirements Inquiry-Item overview display-AMM511 4-76
 - Item Requirements Inquiry-Peg To display-AMM512 4-82
 - Item Resource Report Options display-AMV3A1 5-43
 - Item Resource Report Options display-AMV3HM 5-41
 - Item Resource Report-AML321 5-40
 - description 8-8
 - options display-AMV3A1 5-43
 - run steps to print 5-40
 - use in setting up production families 2-2
 - item revision master record in EPDM 1-19
 - Item Status file
 - description 1-25
 - used in aggregation 2-12, 2-13, 2-22
 - item trial plan
 - based on family-level information 2-5
 - developing 2-20
 - during preinstallation D-3
 - relation to other production plans 2-4
 - item trial plans, maintaining 3-41
- L**
- labor hours
 - basis for resource cost 2-98
 - defined as a critical resource 2-76
 - used for calculating work center time 2-93
 - last extraction date 4-9
 - lead time
 - correcting 2-101
 - used in calculating resource offset 2-81
 - used in generating resource profiles 2-77
 - Lead Time Adjustment (LTADJ)
 - used for planning orders 2-48
 - used in Demand Interface file C-3, C-10
 - Lead Time Deviation Percent
 - calculation 2-101
 - signals inaccurate lead times 2-101
 - lot size (LOTSZ)
 - correcting 2-102
 - printed on Resource Profile Exception Report (AML559) 2-102

- lot sizing
 - used in generating resource profiles 2-77
 - used to plan orders 2-60
- lowest level extracted 4-8
- lowest level planned 4-8
- lowest level, extract to 4-9
- Low-Level Code 4-84

M

- machine hours
 - basis for resource cost 2-98
 - defined as a critical resource 2-76
 - used for calculating work center time 2-93
- manual orders
 - used for master scheduling 2-43
- manual requirements 4-76
- Manufacturing Order Summary file
 - description 1-27
 - used in calculating ATP 2-109
- MAPICS XA
 - applications that work with MPSP 1-15
 - data entry and update 1-22
 - files and file sharing 1-23
- master file queries and searches 1-31
- master files
 - shared by MPSP (description) 1-26
 - updated for master production schedule generation 2-34
 - warnings about file problems A-2
 - ways to improve accuracy A-2
- master level item
 - code required for forecasted items 2-41
 - compared with master scheduled items 2-39
 - definition 1-18
- master production schedule
 - composition of 2-33
 - display and maintain 2-62
 - excessive changes A-6
 - review volatile items often A-3
 - used in MRP's planning 2-69
- Master Production Schedule Planning (MPSP)
 - and computer integrated manufacturing (CIM) companies 1-1
 - and just-in-time (JIT) companies 1-1
 - and manufacturing resource planning (MRP II) companies 1-1
 - before you begin operations 2-1
 - compared to MRP 1-18
 - controlling A-1
 - coordinate processing dates A-3
 - data entry and update 1-22
 - files and file sharing 1-23
 - how MPSP generates a profile 2-77
 - how the application is designed 1-22
 - introduction 1-1
 - major activities 1-12
 - monitoring A-1
 - orders released through MRP 2-69
 - planning horizons 2-28
 - prerequisite applications 1-2

- process for planning orders 2-57
- report descriptions 8-1
- understanding features and calculations 2-1
- use of Demand Interface file C-4
- using menus and displays 1-9
- works with other MAPICS XA applications 1-15
- Master Schedule Item Demand file
 - description 1-25
 - updated during extraction 2-46
- master schedule planning
 - current demand used 2-46
 - horizon 2-30
 - horizons 2-28
 - list of major activities 2-27
 - master production schedule generation 2-34
 - overview 1-10
 - preinstallation activities D-3
 - process for planning orders 2-57
 - selecting product structure levels 2-36
 - types of demand used 2-41
 - use of current receipts 2-15
 - use of demand from Demand Interface file C-4
- master schedule planning horizon
 - defined before master production schedule generation 2-35
 - effect on MRP planning 2-30
 - example 2-31
 - length 2-30, 2-31
 - MPS Current Date 2-31
 - MPS current date 2-31, 2-32, 2-33
 - relation to MRP horizon 2-32
 - relation to time fences 2-71
 - start date 2-31
 - use of production planning periods 2-30
 - use of weekly periods 2-30
 - used for tactical planning 2-31
- Master Schedule Planning Report Options display–AML460 4-61
- Master Schedule Planning Report–AML471
 - description 8-12
 - options display 4-61
- master scheduled item
 - codes required 2-39
 - compared with master level items 2-39
 - component item level 2-36
 - component items, generated demand calculated 2-58
 - exploding the bill of material 2-84
 - extraction 2-46
 - how to define 2-36
 - selecting a level for master scheduling 2-36
 - standard lot size or batch quantity number 2-40
 - types 2-36
- Master Scheduled Item Code field B-1
- Master Scheduled Item Orders file
 - description 1-25
 - used during extraction 2-57
- master scheduled orders
 - maintaining (overview) 2-62
 - orders released through MRP 2-69
 - supporting information for maintaining 2-63

- Master Scheduled Status file
 - description 1-25
 - used in aggregation 2-13
- master schedules, generate 4-4, 4-7
- Material Requirements Planning application (MRP)
 - compared to MPSP 1-18
 - frequent use of new master production schedules A-3
 - interface with MPSP 1-15
 - MPSP orders released through MRP 2-69
 - relation of MRP horizon to MPS horizon 2-32
 - use of MPSP exception codes 2-68
- MPS Current Date
 - coordinates MPS and MRP horizons 2-32
 - effect on CRPLB and CRPLA 2-72
- MPS current date 4-8, 7-1, 7-3
- MPS planning dates
 - cutoff date 4-8, 7-1, 7-3
 - MPS current date 4-8, 7-1, 7-3
 - MPS start date 4-8
 - new cutoff date 7-1, 7-3
 - new MPS current date 7-1, 7-3
- MPS start date 4-8
- multiple lot size 4-90
- multi-warehouse planning 2-50

N

- negative
 - available to promise quantities 2-113
 - cumulative check 2-17
- new cutoff date 7-1, 7-3
- new MPS current date 7-1, 7-3
- New Operating Plan Date
 - effect on aggregation 2-7
- new operating plan date 7-1, 7-3
- new planning run
 - description of 4-9
 - extract 4-9
 - extract to this level 4-9
 - plan orders to this level 4-9
- next level to plan 4-9
- non-MAPICS XA forecasting application
 - creating the Demand Interface file C-4
 - loading the Demand Interface file C-4, C-12
 - updating the Demand Interface file C-13
- non-MAPICS XA order entry application
 - loading the Demand Interface file C-12
 - updating the Demand Interface file C-13

O

- offset
 - calculated for a work center 2-89
 - calculations 2-87
 - definition 2-77
- Open Order Material Detail file
 - description 1-27
 - used in calculating ATP 2-109
- open orders

- maintenance 2-64
 - maintenance completed in IM or PUR 2-64
- operating plan date 7-1, 7-3
- operating plan, family 3-9, 3-12
- Operating Production Targets vs Aggregated Plans display–AML285 3-77
- operation yield percentage
 - current cumulative yield 2-93
 - example of use 2-95
 - used in calculating work center times 2-82
- option backlog
 - definition 2-45
 - extracted for master scheduling 2-46
 - in Demand Interface file C-10
 - used for master scheduling 2-45
- option forecast
 - definition 2-45
 - used for master scheduling 2-45
- option item
 - dependent demand extracted 2-48
 - generated demand calculated 2-58
 - records demand in Master Scheduled Item Demand file 2-47
- Order Policy code 4-90
- order policy code 4-38
 - for production planned item 2-39, 2-60
- order status codes 4-30
- overload of a critical resource
 - indication of potential problems A-6
- overview of MPSP application 1-1

P

- pending changes , MRP uses 2-64
- plan orders to this level 4-9
- Planned Order file
 - description 1-28
 - used in calculating ATP 2-109
- Planner Sequence file, description 1-25
- planning and demand warehouses 2-49
- Planning Information file (PLNINF) 1-28
- planning level, next 4-9
- planning limits, master schedules 4-7
- planning orders
 - assembling demand 2-58
 - maintenance for planned orders 2-64
 - process in MPSP 2-57
- planning status, planning run
 - demand file date 4-8
 - last extraction date 4-9
 - lowest level extracted 4-8
 - lowest level planned 4-8
 - MPS current date 4-8
 - MPS cutoff date 4-8
 - MPS start date 4-8
 - next level to plan 4-9
 - production plan file date (item production plan date) 4-8
- preinstallation activities for MPSP
 - concluding activities D-3
 - for master schedule planning D-3

- for production planning D-3
- for resource planning D-2
- general D-2
- preparing
 - for aggregation 2-6
 - for master production schedule generation 2-34
 - for resource testing 2-75
 - preinstallation activities for MPSP D-2
- price break conversion factor
 - how used in MRP 2-99
 - used as resource conversion factor 2-99
- print major reports
 - Family Operating Plan Report display-AML271 3-81
 - Item Resource Report-AML321 5-40, 5-43
 - Master Schedule Planning Report-AML471 4-61
 - Resource Master File List-AML581 5-14
- Product Data Management application (PDM)
 - interface with MPSP 1-15
- product structure
 - selecting a level for master scheduling 2-36
- Product Structure file
 - description 1-28
 - preparations master schedule planning 2-35
- product structure level, lowest 4-9
- Production Facility file
 - description 1-28
 - required for generating profiles 2-35
- production families
 - beginning and ending dates for item 2-2
 - creating 2-2
 - definition 2-2
 - entering production targets 2-18
 - exploding the bill of material 2-86
 - item's percent of contribution (calculation) 2-13
 - maintaining 2-2
 - maximum targets 2-18
 - priority for each item 2-2
 - quantity significance code 2-2
 - rate per day 2-2
 - required codes in Item Master file 2-2
 - use of Item Resource Report (AML321) 2-2
 - variances and variance percentages (inquiries) 2-24
- Production Family Relationship file
 - description 1-25
 - preparations master schedule planning 2-35
 - processed during aggregation 2-8
 - used in calculating family daily rate 2-18
- Production Plan Build +/-
 - calculation 2-21
 - definition 2-21
 - used to adjust item trial plan 2-21
- production plan file date (item production plan date) 4-8
- production plan, item 3-55
- production planning
 - aggregation 2-6
 - controlling the length of horizon 2-28
 - horizon 2-28
 - includes four types of plans 2-4

- major activities 2-2
- overview 1-10
- preinstallation activities D-3
- use of current shipments and receipts 2-15
- use of demand from Demand Interface file C-4
- production planning dates
 - base plan date 7-1, 7-3
 - demand file date 4-8, 7-1, 7-3
 - item production plan date (production plan file date) 4-8, 7-1, 7-3
 - new operating plan date 7-1, 7-3
 - operating plan date 7-1, 7-3
- production planning horizon
 - horizon 2-28
 - long-range, strategic 2-28
- production planning period
 - beginning day of schedule 2-30
 - determined by Questionnaire answers 2-29, C-5
 - in Demand Interface file arrays C-5
 - relation to master scheduling horizon 2-29
 - three types 2-29, C-5
 - used in Demand Interface file C-5
- production plans
 - developing 2-4
 - family base plan 2-4
 - family operating plan 2-4
 - item production plan 2-4
 - item trial plan 2-4
 - relationship to each other 2-4
 - relationship to master production schedules 2-4
 - sequence in developing plans 2-4
- production targets
 - adjustments 2-5
 - and the business plan 1-4, 1-5
 - entering targets 2-18
 - evaluating 2-19
 - maximum targets 2-18
 - relation to cumulative check 2-17
 - set by management 2-4
- production targets, maintaining 3-9, 3-12
- projected inventory
 - aggregated to family level 2-17
 - calculated for available to promise 2-110
 - calculations 2-17
 - relation to cumulative check 2-17
- production 3-8
- Purchase Order Blanket Release Detail file, description 1-28
- Purchase Order Item Detail file, description 1-28
- Purchase Order Summary file
 - description 1-29
 - used in calculating ATP 2-109
- purchase orders
 - planning warehouses 2-50
- Purchasing application (PUR)
 - and open orders 2-64, 2-65, 2-67
 - relation to MPSP 1-16

Q

- quantity significance
 - specified when setting up family 2-2
- quantity significance, changing 3-83, 3-90, 3-92
- queries, master file 1-31
- Questionnaire
 - coordinated for MPSP and FCST 2-29
 - determines beginning dates of planning periods C-6
 - sets length of production planning periods 2-29
 - sets type of production planning period C-5

R

- rate per day
 - guide for production targets 2-2
 - specified when setting up production family 2-2
- RCPLB, RCPLA
 - definition 2-14
 - used in aggregation 2-14
 - used in master scheduling 2-15
 - used in production planning 2-15
- releasing orders
 - MPSP file updated 2-69
 - MPSP orders released through MRP 2-69
 - per customer order (requires COM) 2-69
- replace
 - Replace Family Base Plans Selection display-AML211 3-52
 - Replace Item Production Plans Family Selection display-AML240 3-55
- replace family base plans 3-52
- Replace Family Base Plans Selection display-AML211 3-52
- replace item production plans 3-55
- Replace Item Production Plans Family Selection display-AML240 3-55
- replacing item production plans
 - creates item production plans 2-22
 - updates item production plans 2-22
 - when to do 2-22
- report displays
 - Family Operating Plan Report Options display-AML261 3-81
 - Item Resource Report Options-AMV3A1 5-43
 - Master Schedule Planning Report Options-AML460 4-61
 - Resource Master File List-AML581 5-14
- reports
 - descriptions of all 8-1
 - help in detecting problems A-4
 - overview of major reports 1-30
- request time-phased materials plan 4-82
- Requirements file
 - description 1-29
 - used in master production schedule generation 2-35
- requirements, held 4-78
- resource conversion factor
 - how to determine 2-99
 - no effect on resource value 2-99
- Resource Master file
 - description 1-26
 - sample file maintenance form 9-1
- Resource Master File List display-AMV3HJ 5-15
- Resource Master File List-AML581

- description 8-28
- run steps to print 5-14
- Resource Master File Maintenance (Add) display-AML592 5-6
- Resource Master File Maintenance (Change) display-AML593 5-8
- Resource Master File Maintenance (Delete) display-AML594 5-10
- Resource Master File Maintenance (Select) display-AML591 5-4
- Resource Master File Maintenance (Status) display-AML595 5-12
- Resource Master File Maintenance form
 - sample form 9-1
- Resource Master file maintenance form-MS-01 9-2
- Resource Master file, maintain 5-4
- resource planning
 - major activities 2-74
 - overview 1-10
 - preinstallation activities D-2
 - resource testing 2-75
 - use of Resource Profile Exception Report (AML559) 2-78
- resource profile
 - calculating resource value 2-98
 - identifying for generation (preparation) 2-75
 - setting up 2-77
 - steps in generating (specific) 2-81
- Resource Profile Build Flag (RSCBF)
 - effect on profile for master scheduled item 2-84
 - field to maintain B-1, B-2
- Resource Profile file
 - description 1-26
- Resource Profile Generation Submit display-AML508 5-30
- Resource Profile Management menu-AMLM30 5-3
- resource profiles, generate 5-17, 5-32
- Resource Requirements Analysis display-AML532 3-35, 4-53
- Resource Requirements Detail display-AML533 3-38, 4-56
- resource requirements planning
 - resource testing 2-75
 - using menu AMLM30 1-10
- Resource Requirements Selection display-AML531 3-32, 4-51
- Resource Test file
 - description 1-26
- Resource Test1 file
 - description 1-26
 - resizing 2-103
- resource value
 - calculations for resource profile 2-98
 - calculations for resource testing 2-99
- review generated requirements 4-82
- rough-cut capacity planning
 - resource testing 2-75
 - using menu AMLM30 1-10
- Routing file
 - description 1-29
 - preparations master schedule planning 2-35
- routings
 - used in generating resource profiles 2-77

S

- safety stock
 - aggregated to family level 2-13

- definition 2-45
- effect on planning orders 2-45
- used for projecting held inventory 2-10, 2-13, 2-22
- SALBF, SALAF
 - definition 2-14
 - examples 2-14
 - used in aggregation 2-14
 - used in production planning 2-15
- scheduled receipts
 - overdue demand 2-61
 - process before aggregating 2-6
- scheduling week
 - beginning day of scheduling week 2-30
- scheduling year
 - 53 week beginning dates C-7
 - 53 weeks, adjustments 2-30
 - adjusting periods at end of year 2-30
- searches, master file 1-31
- service part
 - demand for 2-45
 - master scheduled item 2-37
- shrinkage 4-90
- significance, quantity 3-83, 3-90, 3-92
- site, engineering 1-19
- source, demand 4-38, 4-43
- standard batch quantity (SBQTY)
 - used in generating profiles 2-81, 2-84
 - used in master scheduling 2-39
- standard unit cost (STDUC)
 - from Item Balance file 2-12
 - used to calculate weighted cost 2-12
- start date, MPS 4-8
- steps
 - in calculating available to promise 2-110
- summarize item information to family level (aggregate) 3-2
- supply, calculated in available to promise 2-109
- System Control file 1-24
 - dates changed in aggregation 2-13
 - general description 1-24

T

- tailoring the application 1-22, 1-31
- test family operating plan resources 3-29
- Test Family Operating Plan Resources display-AMV3HR 3-27
- Test Family Operating Plan Resources Selection display-AML541 3-29
- test master schedule resources 4-46
- Test Master Schedule Resources display-AMV3HQ 4-47, 4-59
- testing resources
 - calculating resource value 2-99
 - detecting resource overloads 2-102
 - how MPSP tests a resource 2-102
 - menus to use 1-11
 - purpose 2-102
 - requires resource profiles 2-102
- time fence
 - CMLT Time Fence 2-70
 - Demand Time Fence 2-69

- for maintaining master schedules orders 2-64
- relation to planning zones 2-71
- two fences in MPSP 2-69
- Time Fence, CMLT 4-32, 4-44
- Time Fence, Demand 4-32, 4-44

U

- unit cost default (UCDEF)
 - used to calculate weighted cost 2-12
- updating
 - Demand Interface file C-13
 - files, methods 1-22
 - importance of updated files A-2
 - item production plans 2-22
 - master files before master production schedule generation 2-34
 - online 1-22
- Using eWorkPlace with MAPICS XA documentation 1-31

V

- variance
 - family (calculations) 2-24
 - family plans 2-24
- variance in production plan
 - between family plans and master schedule 2-5
 - between item plans and family plan 2-5

W

- Warehouse Master (WHMST) file 1-29
- warehouses
 - demand 2-49
 - multiple 2-50
 - planning 2-49
- week beginning day
 - relation to production planning periods 2-30
 - set in Questionnaire 2-30
- weighted cost 2-12
- work center
 - capacity calculations 2-96
 - cost used to calculate resource value 2-98
 - offset calculated for profile 2-89
 - special fields for MPSP B-1, B-2

Contents	Index	Exit
-----------------	--------------	-------------