



Infor System21 Master Production Planning

Product Guide

Copyright © 2016 Infor

Important Notices

The material contained in this publication (including any supplementary information) constitutes and contains confidential and proprietary information of Infor.

By gaining access to the attached, you acknowledge and agree that the material (including any modification, translation or adaptation of the material) and all copyright, trade secrets and all other right, title and interest therein, are the sole property of Infor and that you shall not gain right, title or interest in the material (including any modification, translation or adaptation of the material) by virtue of your review thereof other than the non-exclusive right to use the material solely in connection with and the furtherance of your license and use of software made available to your company from Infor pursuant to a separate agreement, the terms of which separate agreement shall govern your use of this material and all supplemental related materials ("Purpose").

In addition, by accessing the enclosed material, you acknowledge and agree that you are required to maintain such material in strict confidence and that your use of such material is limited to the Purpose described above. Although Infor has taken due care to ensure that the material included in this publication is accurate and complete, Infor cannot warrant that the information contained in this publication is complete, does not contain typographical or other errors, or will meet your specific requirements. As such, Infor does not assume and hereby disclaims all liability, consequential or otherwise, for any loss or damage to any person or entity which is caused by or relates to errors or omissions in this publication (including any supplementary information), whether such errors or omissions result from negligence, accident or any other cause.

Without limitation, U.S. export control laws and other applicable export and import laws govern your use of this material and you will neither export or re-export, directly or indirectly, this material nor any related materials or supplemental information in violation of such laws, or use such materials for any purpose prohibited by such laws.

Trademark Acknowledgements

The word and design marks set forth herein are trademarks and/or registered trademarks of Infor and/or related affiliates and subsidiaries. All rights reserved. All other company, product, trade or service names referenced may be registered trademarks or trademarks of their respective owners.

Publication Information

Release: Infor System21 3.1

Publication date: November 29, 2016

Document code: MP

Contents

About this guide	9
Intended audience	9
Related documents.....	9
Contacting Infor.....	9
Chapter 1 Overview	11
Production System Applications	11
Company Profile	11
Master Production Scheduling	12
Material Requirements Planning	14
Production Planning	15
Capacity Requirements Planning.....	15
Forecasting	16
Chapter 2 Maintenance	19
About MPS.....	19
Descriptions and Characteristics of MPS.....	19
Maintain MPS Model Stockrooms [1/MPS, 2/MDU].....	30
MPS Stockroom Model Maintenance Selection Window	31
MPS Stockroom Model Maintenance Stockroom Window	32
MPS Additional Parameters Window	33
MPS Maintain Model Primary Stockrooms Window.....	36
MPS Additional Parameters Planning Window	37
MPS Additional Parameters Run Model Window.....	39
Generate Model Primary Stockrooms [2/MPS]	42
Generate Model Primary Stockrooms Selection Window	42
Maintain MPS Reporting Profile [3/MPS]	43
Maintain MPS Reporting Profile Selection Window	44
Maintain MPS Reporting Profile Detail Window.....	45

Maintain Supply Sourcing Rules [4/MPS].....	45
Maintain Sourcing Rule Details for MPS Demand Detail Window	46
Add/Amend Sourcing Rule Pop-up	47
Maintain Sourcing Rule Details for MPS Demand Summary Window.....	48
Maintain Sourcing Rule Details for MPS Demand Maintenance Window	50
Maintain Sourcing Rule Details for MPS Demand Confirmation Window.....	51
Maintain Model Planning Sequence [5/MPS].....	51
Maintain MPS Model Planning Sequence Model Selection Window.....	52
Maintain MPS Model Planning Sequence Selection Window.....	52
Maintain MPS Model Planning Sequence Detail Window	53
Chapter 3 Forecasting	55
Introduction to MPS Forecasting	55
Maintain Product Family [1/MPF]	56
Maintain Product Family Select Model Window	56
Maintain Product Family Selection Window	56
Maintain Product Family Detail Window.....	57
Maintain Seasonal Indices [2/MPF].....	57
Maintain Seasonal Indices Selection Window	58
Maintain Seasonal Indices Period Window	59
Maintain Seasonal Indices Week Window	60
Maintain Seasonal Indices Period & Week Window	60
Copy Forecast Model [3/MPF].....	61
Copy Model Definition Window	61
Maintain Family Sales Forecast & Maintain Family Stock Forecast [11/MPF, 21/MPF].....	62
Maintain Family Forecast Selection Window	63
Maintain Family Forecast Spread Window.....	65
Calendar Structure Window	66
Maintain Family Forecast Details Window	66
Daily Spread Pop-up	68
Weekly Spread Pop-up.....	69
Select Item Pop-up	70
Stock Level Profile Pop-up	70
Generate Item Sales Forecast & Generate Item Stock Forecast [12/MPF, 22/MPF].....	71
Generate Item Forecast Selection Window.....	71
Generate Item Forecast Window.....	72
Maintain Item Sales Forecast & Maintain Item Stock Forecast [13/MPF, 23/MPF].....	72

Maintain Item Forecast Selection Window	73
Maintain Item Forecast Spread Window	74
Maintain Item Forecasts Details Window	75
Daily Spread Pop-up	77
Weekly Spread Pop-up.....	78
Stock Level Profile Pop-up	78
Spread Item Sales Forecast & Spread Item Stock Forecast [14/MPF, 24/MPF].....	79
Spread Item Forecast Selection Window	79
Spread Item Forecast Details Window.....	80
Chapter 4 Processing.....	83
About MPS Processing.....	83
MPS Automatic Run Parameters [10/MPS].....	87
MPS Automatic Run Parameters Selection Window	88
MPS Automatic Run Parameters Window	88
Machine Manager - Day-end Parameters	89
Run MPS [11/MPS].....	90
Master Production Schedule Run Selection Window.....	91
MPS Run Options Window	91
MPS Additional Parameters Window	94
MPS Additional Parameters Model Details Window	97
Review Demand [12/MPS].....	100
MPS Demand Review Selection Window	100
MPS Demand Review Net Demand Window	101
Resume MPS [13/MPS].....	102
MPS Run Model Selection Window	102
MPS Run Options Details Window.....	102
Review MPS [14/MPS]	103
Model Selection Window	103
Supply/Demand Variance Enquiry Selection Window	103
Supply/Demand Variance Enquiry Window	104
MPS Enquiry Item Selection Window.....	105
MPS Enquiry Summary Window	106
MPS Enquiry Detail Window	107
MPS Supply Maintenance Pop-up	114
MPS All Outputs Pop-up.....	116
MPS Daily Co-product Summaries Window.....	116

MPS Daily Co-product Demand Details	117
MPS Dependent Requirements Window.....	117
MPS Supply Details Window.....	119
MPS Supply Parameters Pop-up	120
MPS Demand Details Window	120
MPS Review Item Schedule Window.....	121
MPS Review Dependent Requirements Window.....	125
MPS Generate Pull List Pop-up	126
MPS Review Scheduled Requirements Window	126
MPS Maintain Scheduled Requirement Pop-up	128
MPS Stockroom Balances Pop-up.....	129
MPS Header Details Pop-up	129
Review Critical Resource Load [15/MPS]	130
Review Critical Resource Load Selection Window	130
Review Critical Resource Load Plant Selection Window.....	131
Review Critical Resource Load Additional Details Window	131
Confirm MPS Suggested Orders [16/MPS].....	132
Confirm MPS Suggested Orders Selection Window.....	132
Confirm MPS Suggested Orders Ranges Window	133
MPS Order Creation Window	133
Confirm MPS Suggested Schedules [17/MPS].....	134
Confirm MPS Suggested Schedules Selection Window.....	134
Confirm MPS Suggested Schedules Ranges Window	135
Confirm MPS Suggested Schedules Confirmation Window	136
Chapter 5 Rough Cut Capacity Planning	137
About MPS Rough Cut Capacity Planning.....	137
Rough Cut Capacity Plan [31/MPS]	138
Rough Cut Capacity Planning Run Window	138
Enquire on Rough Cut Capacity Plan [32/MPS].....	140
Rough Cut Capacity Planning Enquiry Summary Selection Window	140
Rough Cut Capacity Planning Enquiry Summary Window	142
Rough Cut Capacity Planning Enquiry Details Window.....	143
Report on Rough Cut Capacity Plan [33/MPS]	144
Rough Cut Capacity Plan Report Window	144
MPS/Capacity Summary Report [34/MPS].....	145
MPS/Capacity Load Summary Report Window	145

Chapter 6	Reports	149
	Report on Demand [41/MPS]	149
	MPS Demand Report Window	149
	Report on MPS [42/MPS]	150
	Master Production Scheduling Report Window	150
	MPS Report Enter Selection Criteria Pop-up	151
	Report by MPS Planner Action [43/MPS]	152
	MPS Planner Action Report Window	152
	MPS Planner Action Report Selection Pop-up	153
	MPS Planner Action Report Enter Selection Criteria Pop-up	154
	MPS Planner Action Report Action Code Selection Pop-up	155
	MPS Planner Action Report Save Report Selections Pop-up	156
	Report by MPS Valuation [44/MPS]	156
	MPS Valuation Report Window	156
	Cost Presentation Pop-up	158
	Cost Uplift Pop-up	159
	Report on MPS Reporting Profile [45/MPS]	159
	MPS Reporting Profile Window	159
	Report by Available to Ship [46/MPS]	160
	Available to Ship Report Window	161
	Report to Analyse Planning Source of Supply [47/MPS]	163
	Report by Supply/Demand Variance [48/MPS]	164
	Supply/Demand Variance Report Model Selection Window	164
	Supply/Demand Variance Report Selection Window	164
Chapter 7	Exclusivity Checking	167
	Exclusivity Checking	167
	MPS Exclusivity Checking Maintenance Window	167
	Maintain Task Exclusivity Window	168
Appendix A	Glossary	173

About this guide

The purpose of this document is to describe the functions that can be used within the Master Production Planning Module.

Intended audience

The guide is intended for any users of the MP Master Production Planning business module.

Related documents

You can find the documents in the product documentation section of the Infor Xtreme Support portal, as described in the "Contacting Infor" section.

Contacting Infor

If you have questions about Infor products, go to the Infor Xtreme Support portal at www.infor.com/inforxtreme.

If we update this document after the product release, we will post the new version on this Web site. We recommend that you check this Web site periodically for updated documentation.

If you have comments about Infor documentation, contact documentation@infor.com.

Production System Applications

The Production system (Figure 1) comprises seven core applications, governed by a [company profile](#). The link between Production applications and Inventory Management applications is mandatory, whilst the others shown are optional, but functionally desirable for the effective integration of management information.

Company Profile

The Production system, in common with all System21 Aurora applications, operates within a multi-company environment.

A [company profile](#) sets the basic system defaults and [operation](#) policies relevant to each Production company, defines the [costing](#) elements, and defines base calculation parameters which are used by all Production functions.

Access to the [company profile](#) is usually restricted to system managers and implementation project managers who require a comprehensive understanding of the implications of each of its parameter settings. However, awareness of the [company profile's](#) purpose and features is relevant to all users.

Figure 1 - Production System

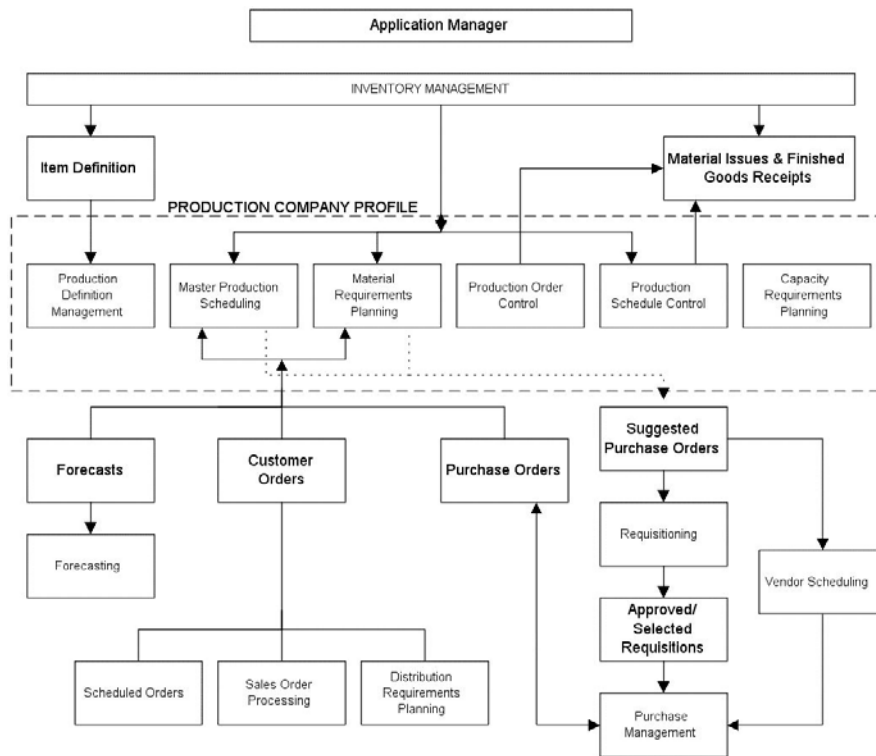

Master Production Scheduling

The Master Production [Scheduling \(MPS\)](#) application (Figure 2) produces a high-level production plan of the critical and sales items. The system then matches the projected [demand](#) for designated products to the ability to [supply](#) based on user-defined [planning models](#) and [planning horizons](#).

[Demand](#) is a function of sales orders, [customer schedules](#), distribution and transfer orders, forecast, and/or manual entries or a user-defined combination. The [supply](#) depends on the availability of associated items and [resources](#) in the Production application. The resulting plan may be based on production orders, [production schedules](#) or a mixture of both. The calculation process for the respective plan generations is simply:

$$\text{Demand} - \text{Supply} = \text{Additional Requirement}$$

A [demand](#) forecast may be determined in the following ways:

- Using the user-entered forecasts defined within MPS
- Using the output from another forecasting application which takes account of historical sales analysis. This would need to be imported into the MPS Forecast files.

The [Master Production Schedule](#) is a time-based plan of existing and suggested supplies to meet customer or other [demands](#) on their due dates. The plan is derived by the system by working

backwards from the [demand](#) due dates, taking account of [production lead times](#) held within the Production database, to calculate latest [start dates](#) to achieve completion by the due dates.

For each [MPS item](#), a plan is derived that can also include [suggested purchase](#) orders and Production resource requirements across the chosen time horizon. The resource requirements can be for critical resource requirements that are defined for the production processes. These may be individually confirmed and purchase orders for [MPS items](#) automatically passed through to the Purchase Management application in advance of further [MRP](#) planning, if required.

In the case where supplies can be processed by multiple facilities, for example different plants or different production lines, critical resource requirements can be used to determine which should be used by reference to the [available](#) capacities of those [resources](#). There is also a tactical line [loading](#) function which allows the re-[scheduling](#) of special [flow routes](#) for [schedule](#)-controlled items; ensuring that all [operations](#) in an [item schedule](#) are re-planned together regardless of the [operation](#) selected. This is equivalent to placing a work order on a different [route](#).

[MPS](#) also incorporates [rough cut capacity planning](#). This may use summary routings to determine the [loading](#) in hours on the Production [resources](#) relative to their [capacity](#) in hours as defined in the Production database.

Figure 2 - Master Production Scheduling

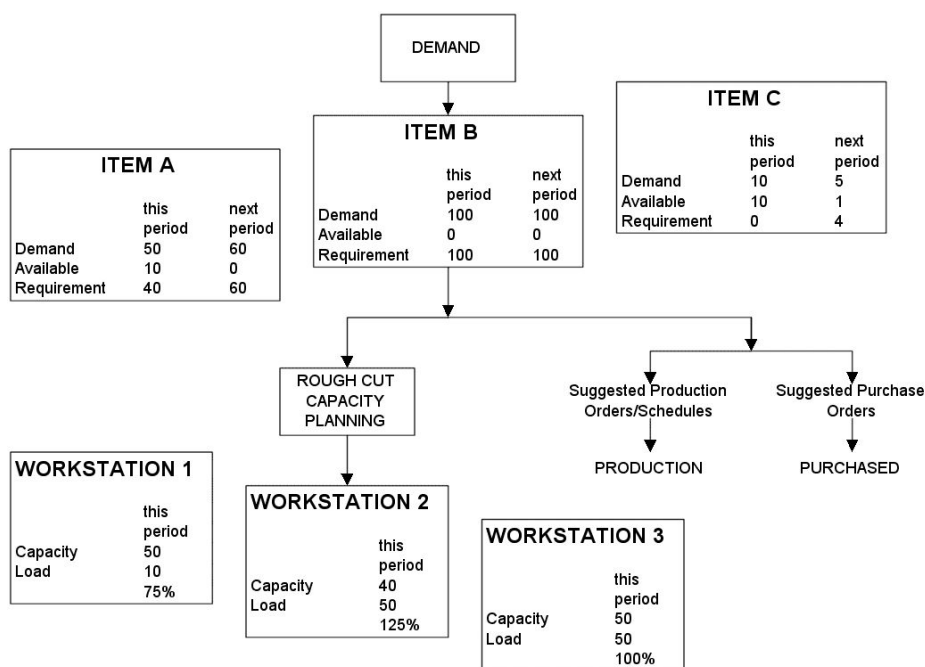

Material Requirements Planning

[Material Requirements Planning \(MRP\)](#) (Figure 3) produces a more detailed plan than [MPS](#), but is essentially completing the same function more comprehensively. [MRP](#) takes account of all the lower-level items, sub-parents and raw materials. Planning is again based upon user-defined models. A model is a set of stockrooms which are used to determine the scope of the plan. One model can be defined as the live model, others being used for simulation and what-if planning.

[MRP](#) differs from [MPS](#) in two major respects. Firstly, it includes all items (except those defined as [MPS items](#)) at all levels in the product structure. Secondly, there is a choice of three modes of processing:

- **Regenerative:** Plan for all items across all structures.
- **Selective:** Plan only selected items and hence selected structures.
- **Net Change:** Plan only items that have had net change triggers created for them as a result of selected transactions or database changes.

In [MRP](#) a [cell](#)-based variation of multi-facility planning is also [available](#). A [cell](#) based [MRP](#) run determines [supply](#) and [demand](#) details for each [cell](#) individually where common [components](#) are used in multiple production [cells](#).

[MRP](#) and [MPS](#) are autonomous modules. Either may be used stand-alone. However, [MRP](#) is normally driven by [MPS demand](#) as shown in Figure 3. A separate [MRP demand](#) may be used to enhance the requirements for dependent [MRP](#) items.

[MRP](#) and [MPS](#) plans are based upon independent user-defined models and [reporting profiles](#). The [reporting profiles](#) may be based on a non-linear time horizon; for example, a three-month plan might be structured as follows:

Next Week	Daily detail
Week 2 - 4	Weekly Detail
Week 5 – 8	Fortnightly detail
Week 8 – 12	Monthly detail

Figure 3 - Material Requirements Planning

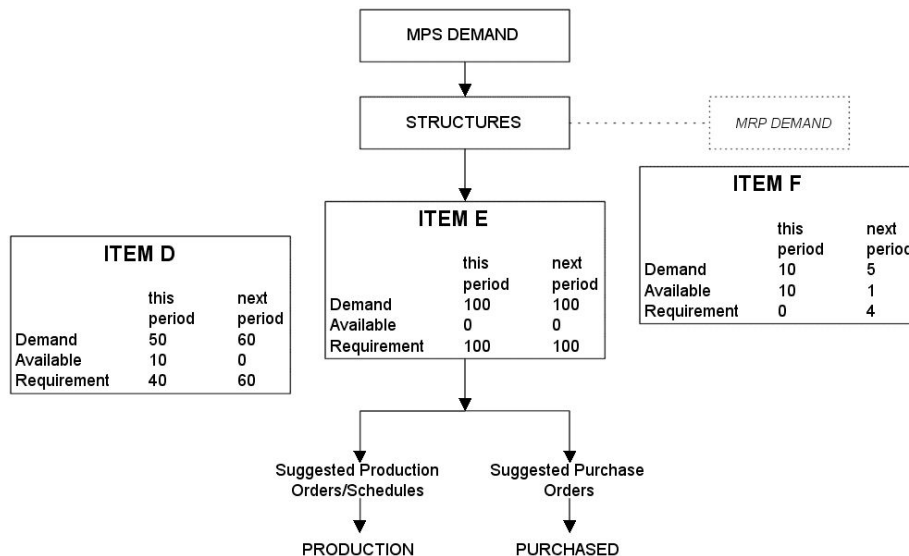

Production Planning

Selective exclusivity checking is possible for submitting and running [MPS](#) and [MRP](#) planning runs. Rather than preventing access to all options in OE, AO, PM, and AC, it is possible to make selections that will control access on a function-by-function basis. For example, database update functions such as Order Maintenance could be prevented from running, but most enquiries and reports could still be [available](#) as normal, by setting the selections. The level of exclusivity is set in Application Manager.

Capacity Requirements Planning

[Capacity Requirements Planning](#) (Figure 4) takes account of [work station](#) capacities, and [planned down times](#) defined across the whole Production application. It uses this information to assess the [demand](#) proposed by [MPS](#) or [MRP](#) plans and determines a [loading](#) factor for each [work station](#).

Database item/[route](#) information is accessed to convert [MPS/MRP supply](#) requirements (in quantities) into the number of hours required (the [load](#)) at each [work station](#). [MPS/MRP](#) planned [supply](#) dates are used to [schedule](#) these required hours into appropriate weekly production time slots at each [work station](#), with reference to [work station](#) standard capacities and with due regard to [planned down times](#) and non-working days affecting the planning [run timescales](#).

Reports and enquiries are [available](#) which compare the weekly [work station](#)/centre hours required and [available](#) within the planning [run timescales](#), so that it is possible to determine whether over or under [load capacity](#) situations occur and thus to decide on action(s) required.

The application enables finite [capacity planning](#) by individual order and [schedule](#), but assumes infinite [capacity](#) at the resource. It is therefore the responsibility of the [planner](#) to complete any fine-tuning of the workload to optimise the [loading](#) factor and hence [utilisation](#) of production [capacity](#).

Figure 4 - Capacity Requirements Planning

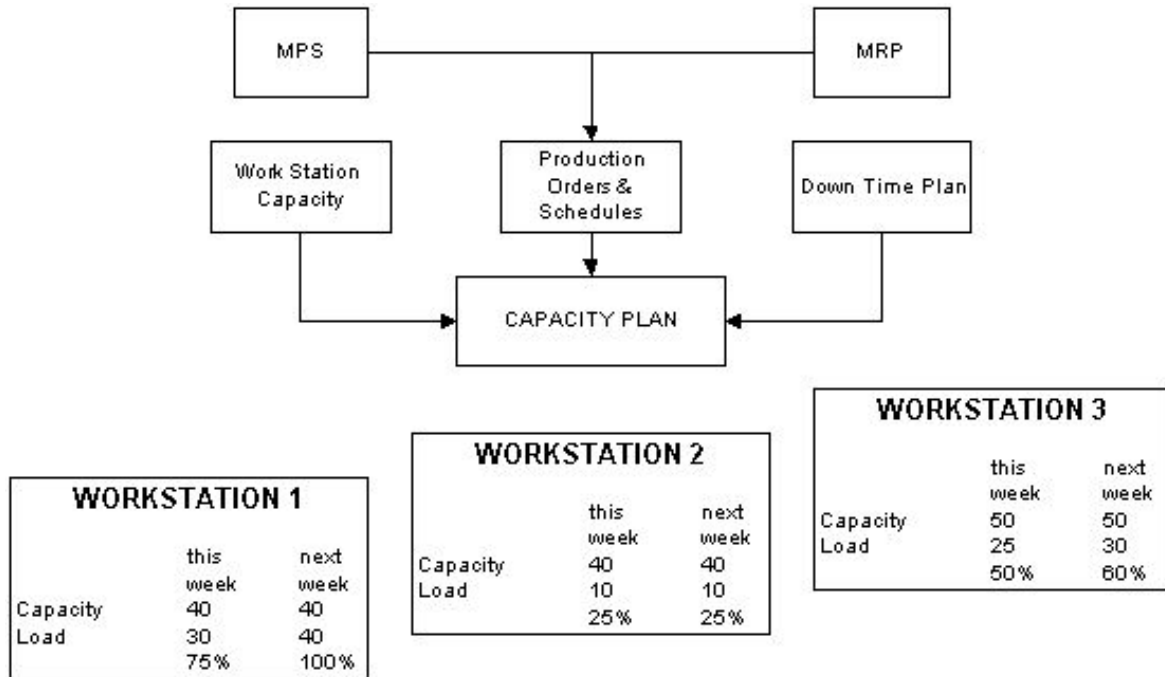

Forecasting

You can use a forecast as a way of [inputting](#) external, [independent demands](#). You do not have to use forecasts, but if you do you can:

- Create item level sales and stock forecasts within the MPS and MRP applications themselves.
- Use the Forecasting application to create sales forecasts and transfer and them to MPS and MRP. The difference between forecasts developed within Forecasting and those developed within MPS and MRP is that those developed in Forecasting are based upon an extrapolation of historical sales figures. MPS and MRP forecasts are generated at item level as percentages of group level forecasts that you define.

Note: Both [MPS](#) and [MRP](#) include forecasting facilities. All functions and definitions apply equally well to both [MPS](#) and [MRP](#).

Product Families

Before you can create a product group forecast, you must [set up](#) a [product family](#). This is any group of items which have the same [item group minor](#) code defined in their item master file records in Inventory Management.

You give each item within the [product family](#) a percentage factor, which is used to determine the quantity of each to be produced.

[Product family](#) forecasting may be either:

- By groups of parents, that is, gross family level forecasts
- By individual parents, that is, discrete item forecasts

You must examine the item ranges within your organisation to establish the most appropriate level for your [item group minor](#) codes.

By creating [item group minor](#) codes for every item, you can specify individual forecasts for each item. However, the benefit of using family level forecasts is that they are likely to be more accurate than individual item forecasts. In addition, there is less detailed [input](#) required.

About MPS

The [Master Production Schedule \(MPS\)](#) produces a high-level production plan of critical items and sales items. It then matches the projected [demand](#) for designated products to the ability to [supply](#), based on user defined [planning models](#) and [planning horizons](#).

[Demand](#) is a function of sales orders, forecast, and manual entries or a user defined combination, or both. The ability to [supply](#) is a function of the availability of associated items and [resources](#) held in the Production database. The resulting plan may be based on production orders, [production schedules](#) or a mixture of both.

The main calculation process for the respective plan generations is:

[Demand](#) - [Supply](#) = Additional requirement

The [demand](#) used to drive [MPS](#) is usually generated from sales orders, [customer schedules](#), and distribution/transfer orders or forecasts, or some combination of them.

Sales order [demand](#) is picked up automatically from Sales Order Processing or Advanced Order Entry.

Forecast [demand](#) may be created by entering forecasts into the [MPS](#) forecasting function, or importing forecasts from some external system into the same files.

Descriptions and Characteristics of MPS

The [Master Production Schedule](#) is a statement of the products or items a company plans to produce, in terms of item numbers and quantities, for specified planning periods and dates.

The [MPS](#) planning process is driven by the definition of [independent demands](#), that is, [demands](#) that cannot be calculated but must come from external sources. In most companies, customer [demands](#) and forecasts constitute nearly all the [independent demand](#).

[MPS](#) works backwards from the specified customer due dates, taking account of product [lead times](#) defined within the Production database, to suggest latest [start dates](#) to achieve completion by the due dates.

[MPS](#) can provide the [input](#) to produce the detailed [material requirements planning \(MRP\)](#).

It can be carried out at any level, but is normally used to determine [schedules](#) for finished items and items that are critical to the production process.

[MPS items](#) are mostly used for the parent items that are sold, but can also include other dependent items lower down in the structure.

It converts sales [demand](#), [sales forecasts](#), overdue requirements and manual requirements into a detailed [production schedule](#) that satisfies the total [demand](#). You use a number of system definition and item level planning parameters to control the calculation of [demand](#) and [supply](#) for each item.

Note: *[Dependent demand](#) for an item is generated from the [demand](#) for its parent.*

[MPS](#) is carried out using a model code. A model consists of a set of stockrooms and production [resources](#) which define the scope of the plan.

The [MPS](#) run is a series of calculations, using data taken from the other modules, to construct a statement of the predicted future production requirement. This should only be done when model maintenance has been completed to give a full definition of the production model.

Any confirmed order or [schedule](#), any released or active order task, and any work in progress ([WIP](#)) stock in production control is taken into consideration in the next full [MPS](#) run.

[MPS](#) may be run and re-run at any time.

You can also enter forecast details before you start the [MPS](#) run.

The [MPS](#) run produces two different kinds of production requirements, depending on the definition for each parent item within the Item Production Details task, that is, whether an item is production order or [schedule](#)-controlled.

For the production order-based items, [MPS](#):

- Re-plans existing orders, by suggesting changes to order quantities and due dates
- Suggests new production orders to meet any additional demand

For [schedule](#)-based items, [MPS](#):

- Re-plans existing confirmed schedules, by suggesting changes to schedule quantities and due dates
- Produces new suggested schedules using the planning route
- Produces operation level schedules that become the basis for daily work station operation schedules
- Uses WIP inventory to net gross requirements on the shop floor

Where production is possible using multiple [routes](#) for the same item, tactical line [loading](#) allows the re-[scheduling](#) of special [flow routes](#) for [schedule](#)-controlled items. This means that all [operations](#) in an [item schedule](#) are re-planned together, regardless of the [operation](#) selected. This is equivalent to placing a work order on a different [route](#).

After running [MPS](#), you can use the Run Rough Cut [Capacity](#) Plan task. [Rough cut capacity planning](#) helps you to determine whether the [schedule](#) is feasible before running [MRP](#). You can use online enquiries and manual updates to view and maintain the [schedule](#) so that it meets the capability of the organisation.

Stock Availability

Available stock for an item is defined as the balance of the physical stock quantity that can be used to satisfy demand for the item within the MPS replenishment planning process.

The availability of stock is partly controlled by the parameters that instruct the planning process to treat stock quantities with the status 'frozen' as either available or unavailable.

For Lot Header controlled Items, the MFSA Parameter is used to manage the treatment of frozen stock. The standard behaviour is to treat frozen stock as unavailable. If the parameter is switched on, then frozen stock is treated as available.

For non-Lot controlled Items and Items under Lot control but without Lot headers, the PLFS parameter is used to manage the treatment of frozen stock. Within the detail control for MPS, there is a setting for Lot controlled Items and another for non-Lot controlled Items. The standard behaviour is to treat frozen stock as unavailable. If the Lot Item control is switched on, then frozen stock for Lot controlled Items is treated as available. If the Non-lot Item control is switched on, then frozen stock for non-Lot controlled Items is treated as available.

The opening [balance](#) for each item is taken as [physical stock](#) minus any unavailable [frozen stock](#) (see above). This is used in the [MPS](#) planning process and appears in the MPS Review as the opening available quantity at the start of the planning period. Any negative opening stock quantities are treated as having a zero [balance](#).

Any item transferred out of one stockroom, but not yet transferred into the target stockroom, is assumed to be in the new stockroom location, but is shown as being [in transit](#). Such balances are not included in the opening stock balance, but appear as supplies on the dates they are due to arrive in the target stockrooms.

Consumption of Forecast

Consumption of forecast is the process of comparing forecasts with orders to determine which ones are used to provide the [MPS demand](#). The Consume Forecast field in the [company profile](#) controls the way in which the calculation is made.

The value entered in the Consume Forecast field is a default value only, and may be overridden by an item's own [demand policy](#).

You can use the following methods:

- Discrete Comparison (field unchecked)

This method of consumption compares the forecast for the forecast period with the total [demands](#) in the same period. The greater of these is used, unless modified by the item [demand policy](#).

The [demand policy](#) flag is set against each item in the Item Production Details task.

- Cumulative Consumption (field checked)

This method compares the cumulative forecast at the end of each period and the cumulative [demand](#) to the same date. The greater of these is used unless modified by the item [demand policy](#).

Demand Policy

You should decide which [demand policy](#) to use after you have decided whether an item is controlled by [Master Production Schedule \(MPS\)](#) or [Material Requirements Planning \(MRP\)](#). The method used

to calculate forecast [demand](#) is controlled by the Consume Forecast field in the [company profile](#), and affects those policies that use internal or external forecasts. The policies are:

- 0 - Total actual demand
- MPS and MRP forecasting do not allow you to enter forecasts. Demand is the sum of sales orders and customer schedules, that is, independent demand, and dependent demand.
- 1 - Forecasts compared with independent demand
- Demand is the greater of sales forecast and sales demand, that is, independent demand.
- 2 - Forecasts compared with total demand
- Demand is the greater of forecast and sales + dependent demand.
- 3 - Independent demand compared with dependent demand
- Demand is the greater of sales and dependent demand. You cannot enter sales forecasts.
- 4 - Explode forecast to inputs

This can be used for a parent item that does not actually exist, but is used as a representation of a set of inputs. The parent is only used for planning. This could be used in a mass customisation environment where the parent item represents the combined requirements of all the variants that are produced. The forecast for the parent is used to create forecasts for its next level of inputs as defined on the designated planning route. The derivation of demand for the inputs themselves depends on the demand policy of each input item. No demand is created for the parent item; that is, no sales or dependent demand is considered.

- 5 - Make to forecast

Demand is equal to the forecast entered. No actual demand is considered.

- 6 - Total demand

Demand is the sum of forecast, independent and dependent demand.

Input Effectivity

A requirement for an [input](#) is generated if:

- Its effective start date is earlier than or the same as the calculated operation start date
- Its effective end date is later than the calculated operation start date
- It has an issuing stockroom on the route in the MPS model

Demand - Daily Net Demand Calculation

For each selected item, the review calculation operates on a daily basis to derive the [net demand](#) from the gross [demand](#) minus [available stock](#).

Therefore, Net Demand = Gross Demand - Available Stock

- Gross Demand = Netted Sales Forecasts, Sales Orders and Dependent Production Order Demand, as defined using the Demand Policy Code + Safety Stock, that is, Target Inventory Level + Stock Forecast
- Available Stock = Physical Stock, for the first period in the run, or Projected Available Stock, for future periods in the run + Outstanding Production or Purchase Order Quantities

This results in three possibilities:

- Net Demand < 0
In this, case there is an over supply situation. Recommendations are made to reduce supply.
- Net Demand = 0
Supply and demand are equal and therefore no actions are suggested.
- Net Demand > 0
This indicates a supply shortage situation. Recommendations are made to Increase existing production orders or generate new suggested orders or schedules.

Demand - Net Demand for Schedule-controlled Items

If there are no production orders, there is a level of [WIP inventory](#) that the planning system needs to recognise in order to avoid over planning materials and production.

[WIP inventory balances](#) are calculated for [operations](#) defined as [count point operations](#) on the [planning route](#) for the item.

Note: Only [count point operation WIP inventory](#) is included.

Note: Negative [WIP](#) is processed as a requirement. This implies that earlier [operations](#) or [WIP](#) transfers have not been completed.

Order Policy Codes

Having calculated the [net demand](#), the review then recommends changes to [supply](#) orders or generates suggested orders, taking into account the [order policy](#) code set in the Item Master file.

Order Policy Code A - Discrete

The required quantity becomes the recommended quantity.

Actual [demand](#) = 100

Recommended quantity = 100

Order Policy Code B - Discrete above Minimum

The required quantity becomes the recommended quantity, unless this is less than the specified [minimum order quantity](#), in which case MOQ is recommended instead.

Actual [demand](#) = 100

[Minimum order quantity](#) = 200

Recommended quantity = 200 (i.e. the [minimum order quantity](#))

Order Policy Code D - Fixed Quantity

The required quantity becomes a product of enough batches of the fixed quantity to satisfy required quantity.

Actual [demand](#) = 100

Fixed quantity = 80

Recommended quantity = 160 (i.e. 2 lots of 80)

Order Policy Code G - Number of Days' Supply

The required quantity is sufficient quantity to satisfy all requirements for the specified number of days' [supply](#) from the initial shortage date

No of days' [supply](#) = 5

Daily [demand](#) = 20, Monday to Friday

Recommended quantity = 100 (i.e. 5 lots of 20)

Order Policy Code H - Multiple above Minimum with Number of Days' Supply

The required quantity is enough batches of the multiply order quantity to satisfy [demand](#), unless this is less than [minimum order quantity](#), in which case the [minimum order quantity](#) is recommended instead

[Minimum order quantity](#) = 200

[Maximum order quantity](#) = 500

[Multiple Order Quantity](#) = 50

Example 1:

Actual [demand](#) = 101

Recommended quantity = 200 (i.e. the [minimum order quantity](#))

Example 2:

Actual [demand](#) = 380

Recommended quantity = 400 (i.e. 8 lots of 50)

Example 3:

Actual [demand](#) = 501

Recommended quantity = 550 (i.e. 11 lots of 50)

Order Policy Code Z - Combined Policies G & H

The required quantity is enough batches of the [multiple order quantity](#) to satisfy [demand](#), unless this is less than [minimum order quantity](#), in which case the [minimum order quantity](#) is recommended instead, all subject to the set number of days' [supply](#).

Calculations are as per Policy H, but subject to the number of days' [supply](#).

MAINTENANCE SUMMARY	A	B	D	G	H	Z
Minimum Order Quantity needed?	no	yes	no	no	yes	yes
Maximum Order Quantity needed?	no	no	no	no	no	no
Multiple Order Quantity needed?	no	no	no	no	yes	yes
Fixed Order Quantity?	no	no	yes	no	no	no
Number of Days' of Supply needed?	no	no	no	yes	no	yes

Time Periods

If a production order is recommended to be cancelled, the [component demand](#) is zero. If you have already issued materials, you must manually return them to the issuing stockroom.

Planning Filters (Re-schedule Policy)

The re-[schedule](#) policy controls the [scheduling](#) processes of [MPS](#) and [MRP](#). [Planning filters](#) determine the extent of quantity and timing changes allowed to existing supplies for each item.

General filters for each production or purchase order and [schedule](#) status are pre-set in the Parameters file, under type WTYP. However, they may be enhanced by the introduction of user-defined codes that can be applied to individual items. For more information, see the Maintain Parameters section in the Production System Utilities chapter of the Production Definition Management product guide.

Whenever a [planning filter](#) is applied or referenced within any of the production applications, consideration is given to whether filters have been defined for the company. If company-specific filters are not set, the default non-company-specific filters are used.

Lot Control - Lot Planning

Stock availability for items subject to [lot control](#) takes account of the lot details [set up](#) in Inventory Management. These details include several fields that may be used to calculate:

- Total shelf life
- Customer shelf life
- First available date (FAD)
- Last available date (LAD)
- Expiry date

Lot Control - Lot Planning Time Periods

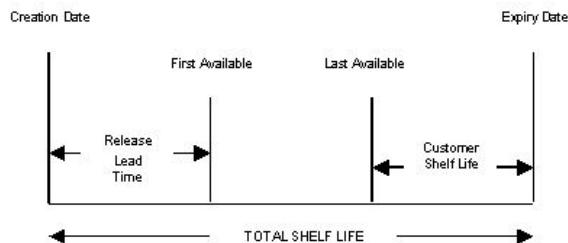

Definitions

- First Available Date = Creation Date + Release Lead Time
- Last Available Date = Expiry Date - Customer Shelf Life
- Expiry Date = Creation Date + Total Shelf Life

Lot Control - Lot Planning Logic

This takes the form of a series of steps to determine which lots are [available](#) during the [planning horizon](#) and what recommendations need to be made about each. Each lot is considered in turn, and recommendations are made about its use depending on its status within the Lot Planning Time Periods. [MPS](#) and [MRP](#) show the following additional [supply](#) status codes:

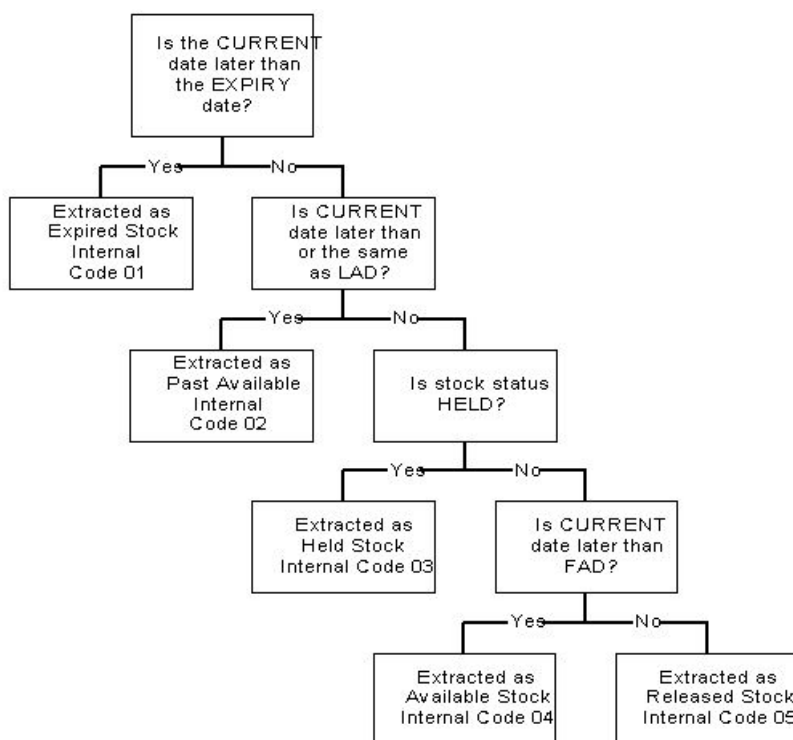

FAD = [First Available Date](#)

LAD = [Last Available Date](#)

If held stock or [available stock](#) is not used, it may cease to be [available](#). If this happens, a new [demand](#) is created for this out of date (OS) stock for the date on which it becomes unavailable.

[MPS](#) nets off [supply](#) and [demand](#) for each day if the [supply](#) does not use up the [available stock](#). During the netting process, [MPS](#) consumes future OS stock. When the potential OS stock is still unused after its [last available date](#), it becomes a real [demand](#) on the next day in order to write off the stock that has become unavailable.

You can define an external [supply](#) code against each internal [supply](#) code. The user-defined or the default external code is used as a [supply](#) status code in [MPS](#) and [MRP](#).

Note: The internal codes are found in the Parameters file under type PSSC. For more information, see the Maintain Parameters section in the Production System Utilities chapter of the Production Definition Management product guide.

Discard Obsolete Schedules

Firmed [item schedules](#) with due dates prior to the current date for the [MPS](#) or [MRP](#) run are not extracted and are deleted from the [planning model](#).

Choice of MPS Items for Control

[MPS](#) is normally used to control the critical production items. The choice of items for control by [MPS](#) is made in the Production Details file and varies according to the requirements of each organisation.

The following diagram illustrates a single item structure that makes item A. In this structure, A is regarded as an [MPS item](#). If the structure went down to several further levels, B and C might be considered as [MPS items](#).

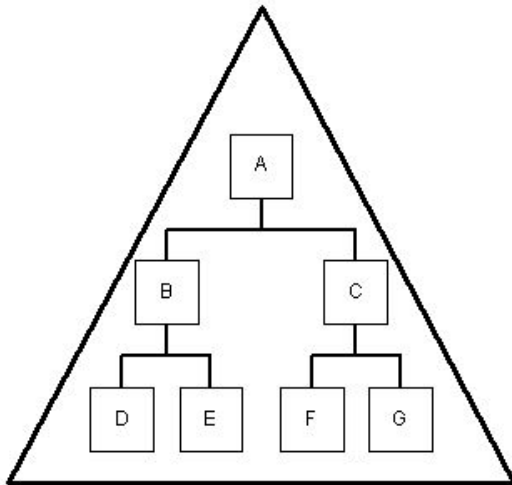

In the next diagram, several parent items are produced from a common raw material or subassembly N. In this case it is likely that the critical items are again the top-level parents H, I, J and K.

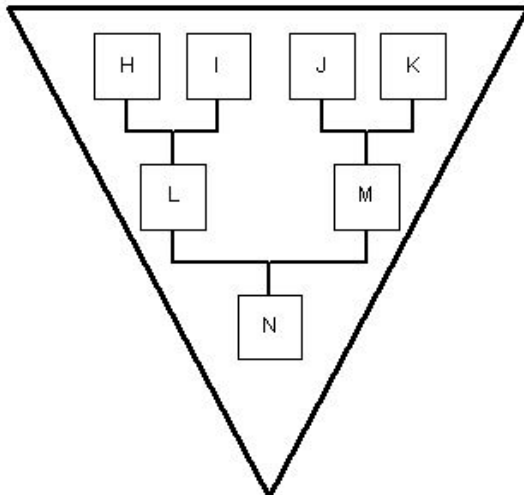

This last diagram shows a structure with a critical [input](#) controlling the production of several parent items. In this case, R may be considered an [MPS item](#) in addition to P and Q.

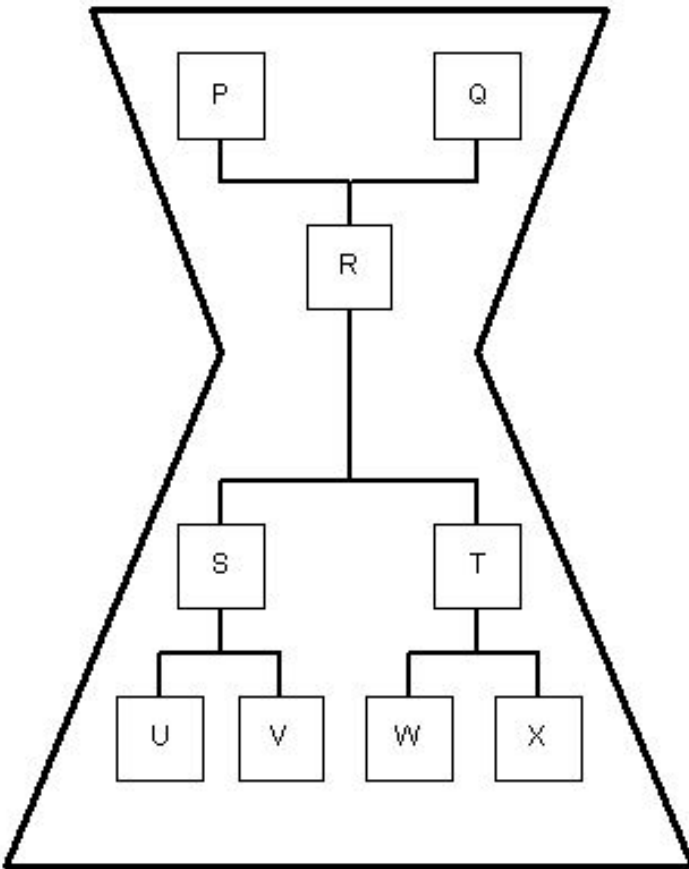

Note: If there are too many [MPS items](#), reviewing the [MPS plan](#) may be difficult because of the volume of information involved.

Before making any decisions about [MPS](#) and [MRP](#) item selection, you must consider other aspects of Production Planning that are [available](#) in each, such as [demand review](#) and [cellular planning](#). These functions have specific requirements for the use of either [MPS](#) or [MRP](#).

MPS - Production Scheduling and Capacity

The structures and [route](#) details are used to calculate the [production lead time](#). This is shown on the next diagram by the length of the connecting lines. Purchase items have a [lead time](#) either from the Stockroom Details file in Inventory Management or from the item/supplier profile in Purchase Management. The number of production items appearing in each time period determines the [load](#) that may be measured against the [capacity available](#).

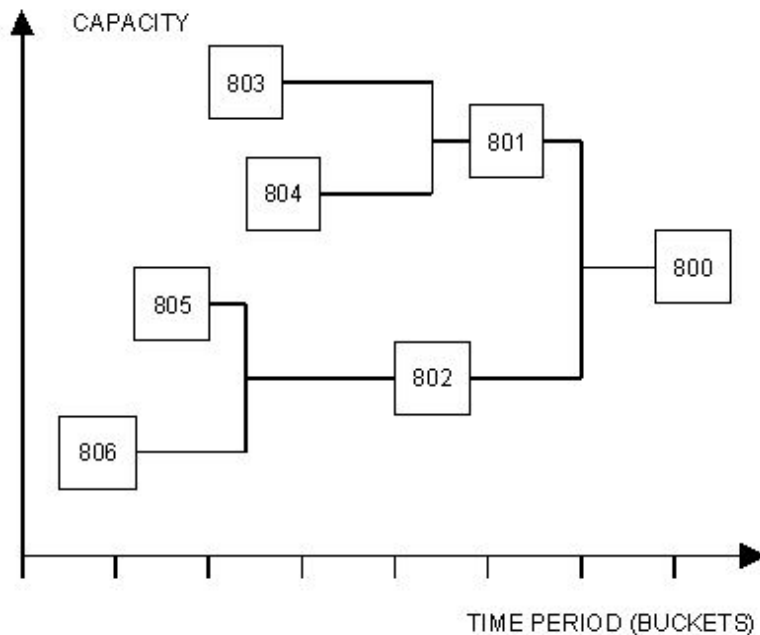

MPS and Multi-plant

In addition to the standard [MPS](#) and [MRP](#) planning, you can also carry out multi-plant planning. With multi-plant functionality, you can produce the same item in more than one production plant. The plants may be on the same site, or widely dispersed.

The plants can be planned centrally or individually. You can define sourcing rules to make decisions on the best plant to [supply](#) a particular item. The relationship between an item's [route](#) and its production plant is created by the receiving stockroom on the [route](#), which you can define to one [MPS](#) plant model. You can also raise transfer or distribution orders to move stock physically from one planning unit to another, to satisfy a [demand](#) in the requesting planning unit.

Maintain MPS Model Stockrooms [1/MPS, 2/MDU]

You use this task to decide which stockrooms are attached to which [MPS](#) model type. The stockrooms define the scope of the [planning model](#) in terms of the stockrooms considered for the planning run. The review process for the model only includes:

- Items that are associated with stockrooms in the list
- Supply and demand associated with stockrooms in the list

Note: The model should include all [WIP locations](#) and [floor stock](#) stockrooms for consideration in the planning run. If plant models are planned centrally, you can define the [WIP locations](#) at central model level only. You must define [floor stock](#) stockrooms at plant level if applicable.

Therefore, you can plan items that are produced in more than one place and restrict the [supply](#) and [demand](#) analysis to selected sites.

When you are defining models for a centrally-controlled multi-plant environment, the central model should include all of the stockrooms in all the plants. The individual plant models should contain only the stockrooms that belong to the plant.

MPS Stockroom Model Maintenance Selection Window

To display this window, select the Maintain [MPS](#) Model Stockrooms task.

You use this window to enter the criteria for the [MPS](#) model you want to maintain.

Fields

Model

You can enter a model to for which to create or maintain the list of stockrooms. A model uses all defined stockrooms to provide an all-round review of your [MPS items](#), considering all [supply](#) and [demand](#) for them.

You can use the prompt facility on this field to select from the Select Model pop-up.

Based on Model

You can optionally enter an existing model in this field. This model must be already [set up](#) in Maintain [MPS](#) Model Stockrooms.

The existing model details are copied to the new model and can be maintained here. Leave this field blank to create a model from scratch.

You can use the prompt facility on this field to select from the Select Model pop-up.

All Stockrooms

Use this field to specify the stockrooms for a model into the model being edited:

Use this checkbox as follows:

Unchecked (default) - To specify stockrooms manually on the [MPS](#) Stockroom Model Maintenance Stockroom window

Checked - To copy all the stockrooms into the selected model to be edited

Functions

Add New Model (F8)

Use this to [set up](#) a new model.

Press Enter to display the [MPS](#) Stockroom Model Maintenance Stockroom window.

MPS Stockroom Model Maintenance Stockroom Window

To display this window, press Enter on the [MPS](#) Stockroom Model Maintenance Selection window.

You use this window to select the stockrooms that are to be included in the model.

Fields

Model

This field displays your selected model for information only and cannot be amended.

Based on Model

If you chose to base a new model on an existing model, the existing model code is displayed for information only and cannot be amended.

All Stockrooms

If you checked this field on the [MPS](#) Stockroom Model Maintenance Selection window, it is displayed for your information only and cannot be amended.

Model Description

If you are creating a new model, enter a text description for the model, using up to 30 characters.

If you are amending an existing model, you can amend the description.

Stockrooms to be Included

If this is a new model, enter the stockrooms that will be associated with it.

Stockrooms are automatically displayed if:

This is an existing model

You have copied stockrooms from another model

You checked the All Stockrooms field on the [MPS](#) Stockroom Model Maintenance Selection window

You can amend or delete the existing stockrooms and add new ones to the list. If you are using a multi-plant model, that is, model type **1**, **2** or **3** for [MPS](#), the stockroom must be unique to the plant or [cell](#) and its central model, unless it is autonomously planned.

You can use the prompt facility on these fields to select from the Select Stockroom pop-up.

Functions

Update/Add (F8)

Use this to save and update your data. If you are creating a new model code using all stockrooms, use this to edit the list created by the All Stockrooms field.

Delete (F11)

Use this to delete the model. You will have to confirm the deletion.

Additional Parameters (F18)

Use this to display the [MPS](#) Additional Parameters window. This is only applicable if you are using multi-plant, [cellular](#) or multi-sourcing planning.

Select **Update (F8)** to validate your data and return to the [MPS](#) Stockroom Model Maintenance Selection window.

MPS Additional Parameters Window

To display this window, select **Additional Parameters (F18)** on the [MPS](#) Stockroom Model Maintenance Stockroom window.

***Note:** If you have not activated multi-plant or [cellular planning](#) in the [company profile](#), only the Model Type field is displayed.*

This window displays the additional [MPS](#) parameters. The [MRP](#) execution level and [primary stockroom](#) for your selected model may also be displayed when the plant model is both an [MPS](#) and [MRP](#) model.

Fields

Model Type

You can define three different model types if you are using multi-plant.

Enter one of the following:

0 or blank - Standard model

This is the default type. You can define many standard models but only one of these can confirm suggestions, that is, the designated live model on the Production [company profile](#). A standard model can reflect the whole organisation, where production item master planning policies determine the [supply](#) method used to satisfy [demand](#). The valid planning basis option for this is Standard.

1 - Central Model

You can define many central models, only one of which can confirm suggestions, that is, the designated live model on the Production [company profile](#). A central model can reflect the whole organisation where, if appropriate, plant model types may be defined to sub-set the organisation stockrooms into unique production locations. Alternatively, you can adopt the single organisation structure of the standard model. You can define sourcing rules for both organisation structures. You can have multiple [supply](#) choices, for example, where an item may be produced on more than one line, or where an item may be manufactured and purchased. The [supply](#) decision is governed by the chosen sourcing rules criteria. Valid planning basis options are:

- Standard
- Multi-plant network
- Single unit sourcing

Note: If plants are to be planned as part of a central model, make sure that each required plant stockroom is defined to the central model stockroom definition.

2 - Production Plant

You can define many plant models to confirm suggestions. You can define plant models to reflect a unique sub-set of the organisation, for example, unit or line. They may be planned autonomously, or centrally as part of the central model. Valid planning basis options, if planned autonomously, are:

- Standard
- Single Unit Sourcing

Note: A stockroom may be defined to only one plant model.

Caution: A plant model type uses stockrooms to determine which plant produces which items. Therefore, you must configure the model stockroom window correctly.

The model type must already be [set up](#) on the software.

You can use the prompt facility on this field to select from the Select Model Type pop-up.

Execution Level

Note: This field is only applicable for plant and [cell](#) models.

When configuring the plant model, you can use this field to decide where and how to firm suggested orders.

Enter one of the following:

0 - Simulation (not live plan)

1 - Autonomous Plan and Execution

This defines the plant model as autonomous. Plan submission and suggested [supply](#) confirmation are controlled independently of a central model.

2 - Centralised Plan and Execution

This defines the plant model as centralised. The central model controls plan submission and suggested [supply](#) confirmation, where multiple plants may be planned during one [MRP](#) run.

You can use the prompt facility on this field to select from the LPLT Model Plan and Execution Level pop-up.

Primary Stockroom

Note: This field is only applicable for plant and [cell](#) models.

You can enter the name of a stockroom in this field. This is the [primary stockroom](#).

This is a non-item-specific [primary stockroom](#), which is the most common stockroom to be defined as the primary for a range of items. An example may be the finished goods receiving stockroom. You can define exceptions to the rule within the Maintain Model [Primary Stockrooms](#) or Generate Model [Primary Stockrooms](#) options. The [primary stockroom](#) is used to determine:

This is a non-item-specific [primary stockroom](#), which is the most common stockroom to be defined as the primary for a range of items. An example may be the finished goods receiving

stockroom. You can define exceptions to the rule with the Model [Primary Stockrooms](#) function or the Generate Model [Primary Stockrooms](#) task. The [primary stockroom](#) is used to determine:

- Default item overrides, defined on the Maintain Item Overrides window
- (If you do not define default overrides, the item master planning parameters will be used.)
- The planning route, where the receiving stockroom of a planning route equals the primary stockroom
- (If you do not define an item stockroom on a planning route, the item master planning route will be used.)
- A suggested purchase order's supply stockroom

This [primary stockroom](#) is only considered if no item model [primary stockroom](#) is defined through either the Model [Primary Stockrooms](#) function or the Generate Model [Primary Stockrooms](#) task. If you do not define a [primary stockroom](#) for an item at [this level](#), the [planning route](#) for any stockroom may be used.

Business Unit

You can optionally enter a business unit. This information is for memo purposes only.

Alternatively, use the prompt facility to select from the BUCS Business Unit Code pop-up.

Business Unit Codes are [set up](#) in parameter type BUCS. For more information, see the Maintain Parameters section in the Production System Utilities chapter of the Production Definition Management product guide.

Site

You can optionally enter a site. This information is for memo purposes only.

Alternatively, use the prompt facility to select from the STES Site Code pop-up.

Site Codes are [set up](#) in parameter type STES. For more information, see the Maintain Parameters section in the Production System Utilities chapter of the Production Definition Management product guide.

Functions

Model Primary Stockrooms (F15)

Use this to display stockrooms at item level on the Maintain Model [Primary Stockrooms](#) window. This function is only [available](#) if you have set the Model Type field to **2** (Production Plant).

Organisational Model (F16)

Use this to display the second Maintain [Organisational Model](#) window, where you can configure the [organisational model](#) for a production plant (model type **2**)

Additional Run Parameters (F18)

Use this to display the [MPS](#) Additional Parameters Planning Parameters window.

Press Enter to update or select **Previous (F12)** to return to the [MPS](#) Stockroom Model Maintenance Stockroom Selection window.

MPS Maintain Model Primary Stockrooms Window

To display this window, select **Model Primary Stockrooms (F15)** on the [MPS](#) Additional Parameters window.

Note: *This function is only applicable to plant model types.*

You use this window to display stockrooms at item level and specify the [primary stockroom](#) for the items.

Fields

Position to Item

Enter the first characters of the item that you want to view and press Enter to display that item at the top of the list.

Item

The [MPS items](#) that have already been [set up](#) cannot be amended but can be deleted. New items can be entered on following lines. The item codes are listed in alphabetical order. The items must be already [set up](#) on the system.

Note: *You can also enter a stockroom in the [Primary Stockroom](#) field and then select **Update /Add (F8)** to add the item to the list.*

Primary Stockroom

Enter the [primary stockroom](#) for an item. This stockroom must be already [set up](#). The [primary stockroom](#) is used to determine:

- Default item overrides (defined in the Item Production Overrides task)
- If you do not define default overrides, the item master planning parameters will be used.
- The planning route, where the receiving stockroom of a route level planning route equals the primary stockroom
- If you do not define an item stockroom on the planning route, the item master planning route will be used.
- A suggested purchase orders supply stockroom

If you do not define a [primary stockroom](#) for an item at [this level](#), the following hierarchical sequence is observed:

- Model primary stockroom
- You enter this on the Model Stockroom Additional Details window.
- Item master primary stockroom

You enter this on the Production Details window.

Note: *When you enter a stockroom in this field, a text description is automatically displayed beside it.*

Options

Delete

Use this to delete the item from the list.

Functions

Resequence (F5)

Use this to re-sequence the items into alphabetical order.

Update/Add (F8)

Use this to save amended or new details.

Select **Update/Add (F8)** to add items to the list, validate the data you have entered and return to the [MPS](#) Additional Parameters window.

MPS Additional Parameters Planning Window

To display this window, select Additional Run Parameters (F18) on the [MPS](#) Additional Parameters window.

Note: You can also access this window from the Run [MPS](#) task.

This window displays the additional parameters for the [MPS](#) run. If a central run model plans multiple planning units, the parameters stated here are extracted from the individual unit definitions.

Fields

Planning Basis

Enter one of the following to indicate the planning basis for the run:

0 - Standard

1 - Multi-plant (multi-plant network)

This basis allows multiple plants to be planned in one [MPS](#) run, allowing interrelationships between items in those plants. Items can have unique [demand](#) and [supply](#) parameters in each plant, and stock may be purchased, manufactured, or transferred from another production location in order to satisfy [demand](#). You can define a unique [supply](#) batch size for each source type, that is, purchase, manufacture and transfer.

Note: This planning basis is [available](#) for central models where multi-plant is defined as a requirement in the Production [company profile](#).

2 - Multi-sourcing (single unit sourcing)

This basis allows multiple [supply](#) options to be considered within a single planning unit. If an autonomous plant is planned where a [demand](#) cannot be satisfied locally, a suggested transfer order may be raised to obtain the stock from another planning unit. You can define a unique [supply](#) batch size for each source type, that is, purchase, manufacture and transfer.

Note: This planning basis is [available](#) for central models where multi-sourcing is defined, or plant models where multi-plant and multi-sourcing are defined as requirements in the [Production company profile](#).

Planning Unit Parameters (1 of 2)

Use Item Time Fence

In preference to a global [time fence](#), you can use a [time fence](#) based on each item's production lead-time as calculated on the Item Master file.

Use this checkbox as follows:

Unchecked - To use the global [time fence](#) entered for the run

Checked - To use the item [time fence](#)

If no [lead time](#) exists for the item, the [run time fence](#) is used.

Use Item End Date

In preference to a global end date for the review of each item, you can use an end date based on each item's cumulative lead-time.

Use this checkbox as follows:

Unchecked - To use the end date entered for the run

Checked - To use individual item end dates

If a cumulative lead-time has not been calculated for the item, the run end date is used. The item end date is calculated as:

Run End Date + Safety Horizon Days

For non-production items, the purchasing lead-time is used for both the manufactured and [cumulative lead times](#).

Dependent Requirements Basis

Use this field to indicate the basis on which [dependent demand](#) is calculated.

Select one of the following:

Suggested (0) - To use only the suggested parent item quantities to determine [dependent demand](#) (that is, suggested orders, [schedules](#) and suggested changes to existing orders and [schedules](#))

Firm (1) - To use only firm quantities, irrespective of any suggested changes to the parent item quantity of existing orders and [schedules](#)

Forecast Basis

Use this field to determine the date to be used as the [demand](#) date on extracted forecasts.

Select one of the following:

Daily (0 or blank) - To use the forecast date

Weekly (1) - To use the end date of the forecast

Confirmed Schedule Policy

Enter one of the following:

0 - To re-calculate the whole [MPS](#) plan

1 - To include any confirmed manufacturing [schedules](#) in the plan

You can use the prompt facility on this field to select from the CNFS Confirmed [Item Schedule Policy](#) pop-up.

Note: This defaults to the value in the Confirmed [Schedule Policy](#) field on the Planning Options window in the [company profile](#), but you can change it.

Include Customer Schedule Arrears

You can choose whether to include [customer schedule](#) arrears.

Use this checkbox as follows:

Unchecked - Not to include [customer schedule](#) arrears

Checked - To include [customer schedule](#) arrears

Functions

Inter-model Extract (F15)

Use this to display the Inter-model Extract window. Use it to import suggested [dependent demand](#) from multiple [planning models](#) into the quoted run model.

Select Update (F8) to validate the data and return to the previous window, or press Enter to display the [MPS](#) Additional Parameters Run Model window.

MPS Additional Parameters Run Model Window

To display this window, press Enter on the [MPS](#) Additional Parameters Planning window.

This window displays more parameters for the [MPS](#) run.

Note: The parameters shown are only considered by the quoted run model.

Fields

Run Model Parameters (2 of 2)

Review Demand

Use this to review the calculated [demand](#) during an [MPS](#) run.

Use this checkbox as follows:

Unchecked - Not to review [demand](#) during the [MPS](#) run

Checked - To review [demand](#) during the [MPS](#) run

Following the review, you need to resume the run using the Resume [MPS](#) task.

MRP Parent Item Extract

During the [MPS](#) run, [MRP](#) items are analysed to determine whether any have [MPS inputs](#). [MRP](#) items with [MPS](#) dependants are incorporated in the plan so that all relevant [demand](#) is [available](#) to the [MPS](#) dependants. However, this may be a time-consuming process, so this field is [available](#) for environments where there are no [MPS](#) dependants to [MRP](#) parents. This can reduce the amount of time taken to determine the items to be planned during the [MPS](#) run.

Select one of the following:

Include (0) - To include the extracts for any [MRP](#) parent items with [MPS inputs](#)

Ignore (1) - To ignore the extracts for any [MRP](#) parent items with [MPS inputs](#)

Item Supply Route Policy

Analysis during the [MPS](#) run determines whether new [MPS item](#) suggestions will be raised as part of a process group. This may be a time-consuming process, so you can use this field for environments where process groups are not used. This can reduce the amount of time taken to determine the items to be planned during the [MPS](#) run.

Select one of the following:

Process Group [Route](#) (0) - If process groups are used within planning for at least some [MPS items](#)

The process group function will be included in the [MPS](#) run.

[Planning Route](#) (1) - If each item has its own [planning route](#)

The process group function will be excluded from the [MPS](#) run.

Daily Summaries for Co-products

You can use this if process groups are included in the [MRP](#) run. If you are using co-product planning, every day the system produces a [supply](#) and [demand](#) summary for each item involved - both the co-product and other items in the process group.

Use this checkbox as follows:

Unchecked (default) - Not to produce daily summaries for [co-products](#) in the [MRP](#) review

Checked - To produce daily summaries for [co-products](#) in the [MRP](#) review

Forecast Netting Basis

Use this to determine the way in which multi-plant forecasts are processed in an [MPS](#) run.

Note: The value you enter in this field is only used when the forecast netting basis in the item's production details is left blank.

Select one of the following:

Central (0)

Use this if you want the forecast for the central model to be included in calculations. These forecasts will be netted against the existing [supply](#) in all plant models attached to the central model, subject to an item's [demand policy](#).

Planning Unit (1)

Use this to include only forecasts for planning units; that is, plants, [cells](#), or both, planned within a central model. These forecasts will be netted against independent and [dependent demand](#) at planning unit level, subject to an item's [demand policy](#).

Note: *This field is only displayed if the planning basis is 1 (Multi-plant).*

Multi-sourcing Basis

Use this to tell [MPS](#) which multi-sourcing rule it needs to apply. You can decide whether to use sourcing rules to satisfy [demand](#), or whether to use an item's own planning policies, that is, item override or item master.

Select one of the following:

Ignore (0) - If you want to ignore multi-sourcing rules, that is, you require single sourcing

Central+Plan.Unit (1) - To consider rules for the central model [set up](#) with subsets of planning units, for example, central and plant models

P.Unit (2) - To consider only those multi-sourcing rules that are defined for the planning unit

Note: *This field is only displayed if the planning basis is 1 (Multi-plant).*

Save Critical Resource Load

Use this field to specify whether to save the end result of all critical [resources](#), that is, [capacity available](#) and [capacity](#) unused, for each [reporting profile](#) period. You could use this to determine why the software suggests producing particular products on particular [routes](#).

Use this checkbox as follows:

Unchecked - Not to save the critical resource [load](#)

Checked - To save the critical resource [load](#)

Note: *This field is only applicable if multi-sourcing is defined as a requirement in the [Production company profile](#).*

Critical Resource Load Policy

Use this field to define how the critical resource opening [capacity balance](#) will be constructed.

Select one of the following:

Refresh (0) - If each critical resource will be fully [available](#) each time the model is run

Alternative Model Profile (1)

If you select this, you must enter a model in the Alternative Resource Model field. Each critical resource will be fully [available](#) each time the model is run. The [reporting profile](#) of the quoted alternative model will be used to configure resource [loadings](#).

Alternative Model with Update (2)

If you select this, you must enter a model in the Alternative Resource Model field. The opening resource [balance](#) will be taken from the quoted alternative resource model. On completion of the

planning run, any additional resource consumption will be reflected in the resource [balance](#) of the alternative model.

Daily Resource [Loading](#) (3)

This allows critical resource [loads](#) to be calculated and viewed in daily [buckets](#) rather than by [reporting profile](#), up to a maximum of one year.

Note: *This field is only applicable if multi-sourcing is defined as a requirement in the [Production company profile](#).*

Alternative Resource Model

You must enter a model in this field if you selected **Alternative Model Profile** or **Alternative Model with Update** in the Critical Resource [Load](#) Policy field.

Note: *This field is only applicable if multi-sourcing is defined as a requirement in the [Production company profile](#).*

Select **Update (F8)** to validate the data and return to the [MPS](#) Additional Parameters window.

Generate Model Primary Stockrooms [2/MPS]

Use this task to generate model or item [primary stockroom](#) links for ranges or groups of items. If used effectively, this greatly reduces the amount of configuration time.

Generate Model Primary Stockrooms Selection Window

To display this window, select the Generate Model [Primary Stockrooms](#) task.

You use this window to enter the model, the items and [primary stockroom](#) for which you want to generate links.

Fields

Model

You must enter an existing model in this field. The model must be either type 2 (Production Plant) or type 3 (Production [Cell](#)).

Item Attribute Type

Enter one of the following:

PGMJ - Item Group Major

PGMN - [Item Group Minor](#)

TECH - [GT Family](#)

Alternatively, use the prompt facility to select from the ITAT Item Attributes pop-up.

If you leave this field blank, it is assumed that you want to enter a range of items in the From and To fields.

Note: *If you enter a value in this field, you can also enter a range of items in the From and To fields.*

From

You can optionally enter the first item in a range.

If you leave this field blank, it is assumed that the range begins from the first item.

You can use the prompt facility on this field to select from the Select Item pop-up.

Note: *The items or item attributes that you select must have been already [set up](#).*

To

You can optionally enter the last item in a range.

If you leave this field blank, it is assumed that the range ends with the last item.

You can use the prompt facility on this field to select from the Select Item pop-up.

Primary Stockroom

You must enter the [primary stockroom](#) code in this field. The stockroom must already have been [set up](#). This will be used as the [primary stockroom](#) for all items in the selected range.

You can use the prompt facility on this field to select from the Stockroom Selection pop-up.

Select **Submit (F8)** to generate the model [primary stockrooms](#) and leave the task.

Maintain MPS Reporting Profile [3/MPS]

Use this task to create a [reporting profile](#) for the model, by which the [supply](#) and [demand](#) information is displayed and reported.

Note: *MPS always calculates [demand](#) and suggests orders on a daily basis.*

The model periods summarise the daily data into convenient time slots or time [buckets](#) for display and presentation.

For example:

DAYS	1	2	3	4	5	6	7	8	9
MPS		A	D	E	G		K	N	O
Suggested		B		F	H		L		P
Orders		C			I		M		Q
and Dates					J				

Using three-day [buckets](#), the orders displayed are:

Period 1	Period 2	Period 3	Period 4
A,B,C,D	E,F,G,H,I,J	K,L,M,N,O,P,Q	-----

Using five-day [buckets](#), the orders displayed are:

Period 1	Period 2	Period 3	Period 4
A,B,C,D,E,F, G,H,I,J	K,L,M,N,O,P,Q	-----	-----

Using nine-day [buckets](#), the orders displayed are:

Period 1	Period 2	Period 3	Period 4
A,B,C,D,E,F, G,H,I,J,K,L, M,N,O,P,Q	-----	-----	-----

Maintain MPS Reporting Profile Selection Window

To display this window, select the Maintain [MPS Reporting Profile](#) task.

You use this window to enter the [MPS](#) model for which you want to maintain the [reporting profile](#).

Fields

Model

Enter the [MPS](#) model for which you want to maintain the [reporting profile](#).

Alternatively, use the prompt facility to select from the Select Model pop-up.

Press Enter to display the Maintain [MPS Reporting Profile](#) Detail window.

Maintain MPS Reporting Profile Detail Window

To display this window, press Enter on the Maintain [MPS Reporting Profile](#) Selection window.

You use this window to specify the time slots for the [reporting profile](#).

Fields

Model

This field displays your selected model.

Calendar Code

Note: You cannot enter a calendar code for live standard or central models. Production uses the company level calendar code by default.

Periods

These are 46 period fields.

Enter the [bucket](#) length, in days, for each period. The periods specified must be continuous. Only the time periods defined here are displayed on reports and enquiries. The more immediate periods are normally shorter, so that relatively few orders are contained within each period. Later periods may be made longer, since such close control is not normally required this far in advance.

If you enter **1** in each period, it means that the critical resource is renewed each day, because the [route](#) is renewed each day.

Functions

Update Details/Review (F18)

Use this to toggle between two different settings.

Select **Review (F18)** to display this window in Review mode. This means you cannot amend any of the time periods.

Select **Update Details (F18)** to display this window in Update mode, as indicated in the top right-hand corner of the window. This means you can amend any of the time periods.

Press Enter to save any amendments and return to the Maintain [MPS Reporting Profile](#) Selection window.

Maintain Supply Sourcing Rules [4/MPS]

Use this task to define multiple [supply](#) choices for a given [demand](#) point for an item. These choices defined in the sourcing rules are considered during the [MPS](#) run to determine the method of satisfying the [demand](#). The [supply](#) choices can be a series of [routes](#) in a user-defined sequence. In this case critical resource definitions can be used to allow multi-sourcing to take resource capacities into account when allocating production to the various [available](#) facilities.

You can define sourcing rules at the central model level, or at the plant model level. This should conform to the sourcing rule access method defined for the source type within the Inventory application. If the access method is All [Demand](#) Points, the sourcing rules should be defined against the plant code only. If the access method is Warehouse/Plant, the sourcing rules should be defined against both the central and plant models. If multi-sourcing alone is used, the sourcing rules should be defined for the live model.

If the sourcing rule is at the central level, then you can define either a default rule or separate rules for each plant model. This allows for different sourcing methods depending on where the [demand](#), forecast, independent and dependent, comes from; that is, central model or plant specific model.

Note: You must maintain sourcing rules for items that may be supplied by more than one [route](#) or method, where currently critical resource levels will determine the [supply](#) choice. You can introduce further sourcing rule types as required. If sourcing rules are not present for a given [demand](#) situation, the default [supply](#) method for the [demand](#) point will be used ([planning route](#) or [suggested purchase order](#)).

Fields

Activity

Enter the code for the sourcing rule activity you want to maintain.

Press Enter to display the Maintain Sourcing Rule Details for [MPS Demand](#) Detail window.

Maintain Sourcing Rule Details for MPS Demand Detail Window

To display this window, press Enter on the Maintain Sourcing Rule Details for [MPS Demand](#) Selection window.

This window lists all the sourcing rules you can use for the activity. Details displayed on this window include:

- The sourcing rule type
- Critical Resource (004) applies to all rules regardless of whether critical resources are to be used or not.
- The item for which the sourcing rule is defined
- The demand point for which this sourcing rule defines supply sources
- For multi-plant, this should be the central model and the plant model, or just the plant model (depending on the sourcing rule access method). For multi-sourcing this should be the planning model.
- The dates within which the sourcing rules are in effect

Fields

Pos'n to Item

Enter the item, or part of the item reference code, that you want to display at the top of the window and then press Enter to change the display.

W'House

Specify the required central or plant model for setting position. This can only be entered in conjunction with an item.

Options**Amend**

Use this to amend an existing sourcing rule on the Amend Sourcing Rule pop-up.

Details

Use this to enter more specific information for the sourcing rule on the Maintain Sourcing Rule Details for [MPS Demand](#) Rules window.

Delete

Use this to delete the selected sourcing rule details.

Functions**Add (F10)**

Use this to display the Add Sourcing Rule pop-up, where you can enter new rules.

Select **Previous (F12)** to display the Maintain Sourcing Rule Details for [MPS Demand](#) Selection window and select another sourcing activity.

Alternatively, select **Exit (F3)** to leave the task.

Add/Amend Sourcing Rule Pop-up

To display this pop-up, select Amend against a line for amendment or select **Add (F10)** on the Maintain Sourcing Rule Details for [MPS Demand](#) Detail window.

Use this pop-up to make amendments to the selected sourcing rule line or to add a new sourcing rule.

Fields**Sourcing Rule Type**

Enter the sourcing rule type that this sourcing rule will use. The only one currently [available](#) for [MPS Demand](#) Sourcing is Critical Resource (004). The sourcing rule type normally describes how the rule is applied, but is used for all [MPS](#) sourcing rules, even when critical resource [loading](#) is not applicable to the source type.

You can use the prompt facility on this field to select from the Select Sourcing Rule Type pop-up.

Item

Enter the item to which the sourcing rule applies.

Alternatively, use the prompt facility to select from the Select Item pop-up.

Warehouse/Plant

Enter the [MPS](#) model where the sourcing rule applies. In a single plant multi-sourcing environment this will be the [planning model](#). In a multi-plant multi-sourcing environment, it will be the central model or a plant model. In the second case, the multi-sourcing basis specified on the [MPS](#) Additional Parameters Planning Parameters window dictates which one of these it should be. If it is set to **1** (Central and Planning Unit), this should be the central model. If it is set to **2** (Planning Unit), it should be the plant model. This field is only [available](#) if the [Demand](#) Point Access on the Sourcing Rule Access for [MRP Demand](#) is set to **1** (Warehouse/Plant).

You can use the prompt facility on this field to select from the Select Model pop-up.

Demand Point

Enter the [demand](#) point, usually a plant model, where [demand](#) for the item will come from for this sourcing rule. This can only be entered if the Warehouse/Plant field holds a central model. An entry is required here if the multi-sourcing basis on the [MPS](#) Additional Parameters Planning Parameters window is set to **1** (Central and Planning Unit). This field is only [available](#) if the [Demand](#) Point Access on the Sourcing Rule Access for [MPS Demand](#) is set to **1** (Warehouse/Plant).

Effective Date From/To

Enter or select the date range within which the sourcing rule is in effect.

Select **Update (F8)** to validate and update the sourcing rule line and display the Maintain Sourcing Rule Details for [MPS Demand](#) Rules window.

Maintain Sourcing Rule Details for MPS Demand Summary Window

To display this window, select Details against line on the Maintain Sourcing Rule Details for [MPS Demand](#) window.

Alternatively, select **Update (F8)** on the Amend Sourcing Rule pop-up.

Use this window to view and select the sourcing rule details for maintenance. These rules define the [supply](#) sources that you wish to use to satisfy the [demand](#) source displayed. The details indicate the sequence in which the [supply](#) sources will be applied, whenever [capacity](#) is exceeded on preceding sources. Other details include:

Header detail (demand source)

- The item code (and description) to which the sourcing rule applies
- The planning model (and description) or the central model (and description) and the plant model (and description) where the demand for the item originates
- The rule type (which is always 004 for MPS sourcing rules)
- The date range within which the rule is in effect

Supply sourcing detail (both sourcing rule details and default values)

- The source type (Tp), which indicates how the item is sourced (this is effectively make, buy or transfer control)
- The company (Co), which is for enterprise orders and is not used in MPS sourcing
- The route (R), which, if the source type is Manufacture, holds the manufacturing route code of the supply source route
- The process group, which, if the source type is Manufacture, is displayed if the item is manufactured as a co-product item produced as part of a process group
- In this case, the route code is the process group route code
- The stockroom (SR), which, if the source type is Transfer, holds the sourcing stockroom
- The plant, which, if the source type is Transfer, displays the sourcing plant, which is the plant in which the sourcing stockroom is located
- The supplier, which, if the source type is Purchase, holds the sourcing supplier for the item but is not available for MPS sourcing
- The sequence, which, if there is a supplier, displays the address sequence for the supplier
- The lead time
- You can enter a lead time for the source which MPS will use in its scheduling routines.
- The supply policy (not available for default values), which allows you to define whether a supply source can be used if it is only capable of supplying part of the requirement, or whether it must be capable of fulfilling the full requirement for it to be used
- The sourcing rule sequence (not available for default values)
- When there is insufficient capacity on one source, the next one in the sequence is used. The sequence of supply sources is used in critical resource load planning, where critical resources can only be planned to be utilised up to their available capacities
- When the [MPS](#) run encounters a [demand](#) situation which is to be fulfilled using critical resource [load](#) planning, it tests each of the detail [routes](#) in ascending user-defined sequence, checking to see whether there is sufficient remaining [capacity](#) in the period (after taking into account other supplies that have already been [loaded](#)) of all the critical resource requirements defined for the [route](#). The [supply](#) policy defines whether partial supplies can be planned when there is some resource [available](#) but not enough for the full requirement. If the rule criteria cannot be met (that is, there is insufficient critical resource), [MPS](#) goes on to the next [route](#) in sequence.
- If all of the defined detail routes fail to satisfy the full requirement, the remainder will be satisfied by the supply source defined in the default values. If default values are defined, the supply for the remaining requirement will be raised against the default supply source regardless of the rule criteria. If not defined, the first detail route in sequence will take on the role of the default supply source.

Options

Amend

Use this to amend a sequence.

Delete

Use this to delete a sequence.

Functions

Add (F10)

Use this to add a new sourcing rule sequence. This displays the Maintain Sourcing Rule Details for [MPS Demand](#) window. Additional sources of [supply](#) can be added with sequence numbers that determine the order in which they will be considered within [MPS](#) critical resource [load](#) planning.

Default Values (F14)

Use this to display the Maintain Sourcing Rule Details for [MPS Demand](#) Maintenance window, allowing default [supply](#) source values to be maintained for the sourcing rule. In a [capacity](#) constrained planning environment, this can be used to define a dummy [supply](#) source against which any [overload](#) will be raised. Alternatively, for example, a purchasing source could be defined for use once all production [capacity](#) is exhausted.

Select **Previous (F12)** to re-display the Maintain Sourcing Rule Details for [MPS Demand](#) Detail window.

Maintain Sourcing Rule Details for MPS Demand Maintenance Window

To display this window, select **Add (F10)** or **Default Values (F14)** on the Maintain Sourcing Rule Details for [MPS Demand](#) Summary window.

Use this window to add and maintain detail lines for the sourcing rule.

Fields**Sequence**

Enter a sequence number to specify the order in which [supply](#) sources ([routes](#)) are to be used in the [MPS](#) critical resource planning process. As [capacity](#) is exceeded in each one, so processing moves on to the next [route](#) in the sequence.

Source Type

Enter the source type of the item source. This effectively defines whether the source is make, buy, or transfer.

You can use the prompt facility on this field to select from the displayed pop-up.

Route

Enter the [supply](#) source [route](#) to be used in the planning process, according to its associated sequence.

You can use the prompt facility on this field to select from the displayed pop-up.

Process Group

Enter the process group, if the item is a co-product item produced as part of a process group and the [route](#) is a process group [route](#).

You can use the prompt facility on this field to select from the displayed pop-up.

Supply Policy

This field controls whether [supply](#) sources that have insufficient [resources](#) to satisfy the full [demand](#) requirement that is presented can nevertheless be used to fulfil that part of the requirement for which they are capable.

Enter one of the following:

0 - Full [supply](#)

The [supply](#) source must be able to satisfy the full requirement before it can be used.

1 - Part [supply](#) (decimal)

The [supply](#) source can be used even though it can only partially satisfy the requirement.

2 - Part [supply](#) (integer)

This rounds a partial [supply](#) to a whole number.

Effective From/To

The date range displayed defaults from the previous window.

Select **Update (F8)** to validate and update your entries and return to the previous window.

Alternatively, press Enter to validate your entries and display the Maintain Sourcing Rule Details for [MPS Demand](#) Confirmation window.

Maintain Sourcing Rule Details for MPS Demand Confirmation Window

To display this window, press Enter on the Maintain Sourcing Rule Details for [MPS Demand](#) Addition window.

This window is reserved for future development.

Select **Update (F8)** to update the data in the window and return to the Maintain Sourcing Rule Details for [MPS Demand](#) Rules window.

Maintain Model Planning Sequence [5/MPS]

When a suggested transfer order [supply](#) is created by planning, as the result of the application of a sourcing rule, a reciprocal [demand](#) is simultaneously placed on the stockroom (and therefore the plant) from which the transfer is to be effected. As this is a brand new [demand](#) generated by the detailed planning process itself, it cannot be detected during the [demand](#) extraction phase, which takes place at an earlier stage in the process. This task ensures that this [demand](#) is guaranteed to be generated before the [supply](#) is planned in the Transfer From stockroom. It is also required that this [demand](#) is recognised in this stockroom and suitable supplies planned to satisfy such [demand](#).

This implies a hierarchy of plants, because certain plants must be planned before others, being those which feed them.

This task allows a central model to be selected, and then, for each plant model within it, a sequence number can be specified. Alternatively, the plant model sequence can be specified for individual items, recognising the fact that the plant network might operate in different directions for different products.

Planning operates according to the model sequences defined in the task described above. Plants are processed in ascending sequence number order. This sequence is applied to each item that is planned in the plant, unless a specific sequence number is given to an item/plant combination, in which case that sequence number supersedes the plant's own. Transfer order [supply](#) suggestions generated for plants that are earlier in the sequence are passed as transfer order [demands](#) to plants that are later in the sequence. This [demand](#) is then planned in the later plants, according to their own [supply](#) rules. A single item may be thus supplied by a series of transfers between plants, all planned by a single planning run.

Maintain MPS Model Planning Sequence Model Selection Window

To display this window, select the Maintain Model Planning Sequence task.

This window invites you to select a model code. When you are using [MPS](#), this should be a central model.

Fields

Model

Enter the [MPS](#) model for which you want to maintain the [reporting profile](#). This should be a central model.

Alternatively, use the prompt facility to select from the Select Model pop-up.

Press Enter to display the Maintain [MPS](#) Model Planning Sequence Selection window.

Maintain MPS Model Planning Sequence Selection Window

To display this window, press Enter on the Maintain [MPS](#) Model Planning Sequence Model Selection window.

Fields

Include All Plants/Cells

Enter one of the following:

0 - Not to include all plants/[cells](#)

1 - To include all plants/[cells](#)

Press Enter to display the Maintain [MPS](#) Model Planning Sequence Detail window.

Maintain MPS Model Planning Sequence Detail Window

To display this window, press Enter on the Maintain [MPS](#) Model Planning Sequence Selection window.

If you choose to include all plants, they will be listed from the outset as soon as the window is displayed. If not, the list area will initially be empty. Each list item that is displayed can be assigned a sequence number. New list items can be defined by entering plant codes or item/plant combinations. These can also be given a sequence number.

The planning system plans item/plant or plants with the lowest sequence number first, then the second lowest, and so on. For example, Item 800 will be planned in Plant P1 before Plant P2, whereas Item 801 will be planned in Plant P2 before Plant P1. This would be a suitable set-up if Item 800 is supplied to Plant P1 by transfer from Plant P2 and Item 801 is supplied to Plant P2 by transfer from Plant P1. These definitions override the basic plant sequence, which will cause all other Items to be planned in Plant P1 before Plant P2.

Note: *The sequence numbers have no significance other than their pure numeric sequence. It may be desirable to leave gaps between sequence numbers to enable easy insertion of additional details. The actual numbers shown are just an example of how they might be used. 999 is the highest number available*

Caution: If an item or a plant is not given a sequence number, it is placed at the beginning of the sequence, as if it had a sequence number of zero. This means that sequence numbers should be given to all items/plants that need to be planned in a specified order.

When [MPS](#) is run, if plant sequences are defined, each item that belongs to the specified plants is processed in the order given. An item will be completely planned in one plant before the processing moves on to the next. An item is fully planned in all its plants before the next item is planned. This means that a given item/plant combination should only have one sequence number. It is not possible, for example, for a different sequence to be used because a particular sourcing result has occurred. The sequence in which plants are planned for items is wholly as determined by the user. The planning process has no knowledge of possible relationships between plants that may mean that a particular sequence is required.

Note: *The sequence in which plants are planned is not determined by the planning run itself. The correct sequence must be specified by the user; otherwise, the function will not operate as implied by the Sourcing Rules. In other words, the Sourcing Rules themselves are not used to automatically determine the order in which plants are processed.*

Select **Update (F8)** to save your changes and return to the Maintain [MPS](#) Model Planning Sequence Model Selection window.

Introduction to MPS Forecasting

You can use a forecast as a way of [inputting](#) external, [independent demands](#). You do not have to use forecasts, but if you do you can:

- Create item level sales and stock forecasts within the MPS application itself.
- Use the Forecasting application to create sales forecasts and transfer and them to MPS. The difference between forecasts developed within Forecasting and those developed within MPS is that those developed in Forecasting are based upon an extrapolation of historical sales figures. MPS forecasts are generated at item level as percentages of group level forecasts that you define.

Note: Both [MPS](#) and [MRP](#) include forecasting facilities.

Product Families

Before you can create a product group forecast, you must [set up](#) a [product family](#). This is any group of items which have the same [item group minor](#) code defined in their item master file records in Inventory Management.

You give each item within the [product family](#) a percentage factor, which is used to determine the quantity of each to be produced.

[Product family](#) forecasting may be either:

- By groups of parents, that is, gross family level forecasts
- By individual parents, that is, discrete item forecasts

You must examine the item ranges within your organisation to establish the most appropriate level for your [item group minor](#) codes.

By creating [item group minor](#) codes for every item, you can specify individual forecasts for each item. However, the benefit of using family level forecasts is that they are likely to be more accurate than individual item forecasts. In addition, there is less detailed [input](#) required.

Maintain Product Family [1/MPF]

Use this task to [set up](#) and maintain product families or groups.

Note: Before you can [set up](#) a [product family](#), you must create the model you are going to use, using the Maintain [MPS Reporting Profile](#) task.

Maintain Product Family Select Model Window

To display this window, select the Maintain [Product Family](#) task.

You use this window to enter the [planning model](#) that contains the [product family](#) you want to maintain.

Fields

Model

Enter the [planning model](#) that contains the [product family](#) you want to maintain.

Alternatively, use the prompt facility to select from the Select Model pop-up.

Press Enter to display the Maintain [Product Family](#) Selection window.

Maintain Product Family Selection Window

To display this window, enter a [planning model](#) and then press Enter on the Maintain [Product Family](#) Select Model window.

This window lists all the item group minor codes that are defined to the planning model you entered on the previous window. If a forecast profile already exists for a particular product family, **Y** is displayed against it in the Profile field.

Note: [Item group minor](#) codes are defined in Inventory Management.

Options

Select Product Family

Use this against the relevant line to select a particular [product family](#). The Maintain [Product Family](#) Detail window is displayed.

Note: When planning for process groups the forecast must be for the items actually sold, that is, each co-product, and not the process group itself. This means that you must assign the product group minor codes to the [co-products](#).

Select a [product family](#) to display the Maintain [Product Family](#) Detail window.

Maintain Product Family Detail Window

To display this window, use Select [Product Family](#) against a line on the Maintain [Product Family](#) Selection window.

This window displays all items currently linked to the selected [item group minor](#), or [product family](#). The following details are displayed:

- The item code and description
- One of the following source types for each item:
 - MAN - Manufactured
 - PHM - Phantom
 - PUR - Purchased
 - B/O - Bought out
 - TL - Consumable tool
 - RTL - Reusable tool
 - GAU - Gauge
- The item type
- Whether the item is an MPS or an MRP item

Every item scheduled by MPS has **1** displayed against it. This means that the forecast generated for the item is used in MPS to determine the demand for it. MRP items have **0** displayed against them.

Fields

Percentage

For each item, enter the percentage of the group value to be represented by that item. This figure represents the percentage factor, which is used to determine the quantity of each to be produced.

Note: *The sum of these percentages must add up to 100.*

Note: *If the [demand policy](#) for an item does not include [sales forecasts](#), that is, it is either 0 or 3, an asterisk (*) is displayed beside it. You set the [demand policy](#) within the item's production details.*

After you have entered the values, press Enter. The software checks that the percentages add up to 100%. Select **Update (F8)** to update the details and return to the previous window.

Maintain Seasonal Indices [2/MPF]

Use this task to create seasonal indices. You can use seasonal indices to spread your forecasts over days, weeks or periods, automatically. You enter a distribution pattern, which spreads the production totals over the days, weeks, and periods of the [planning horizon](#). When you generate an [MPS](#) forecast, you can enter a [seasonal profile](#) on which to base the forecast. The software will spread the forecast quantity according to the [seasonal profile](#).

Maintain Seasonal Indices Selection Window

To display this window, select the Maintain Seasonal Indices task.

You use this window to enter the section criteria for the seasonal indices you want to maintain.

Fields

Model

Enter the [MRP](#) model for which you want to maintain a [seasonal profile](#).

Alternatively, use the prompt facility to select from the Select Model pop-up.

Profile Code

Enter a code for the [seasonal profile](#) index you want to maintain.

Alternatively, use the prompt facility to select from the Select Seasonal Index pop-up.

Note: *This profile code itself does not have to be unique. You can have two profiles with the same code if the year or model is different.*

Year

Enter the year for which you are forecasting.

Note: *The model and year combination must exist on the calendar.*

Entry Level

This field indicates whether the profile will be based on periods or weeks.

Select one of the following:

Period (1) - To enter your forecasts over calendar periods

You can then break the period forecast down into weeks within that period.

Weekly (2) - To enter the forecasts over weeks

Base on Profile

If you are creating a new profile, you can enter a profile from which the details will be copied. The model, year and entry levels of the new and existing profiles must match.

Alternatively, use the prompt facility to select from the Select Seasonal Index pop-up.

Note: [Seasonal profiles](#) are year-specific and model-specific. You need to create profiles for each year, for each model.

If you selected Period in the Entry Level field, press Enter to display the Maintain Seasonal Indices Period window.

If you selected Weekly in the Entry Level field, press Enter to display the Maintain Seasonal Indices Week window.

Maintain Seasonal Indices Period Window

To display this window, select **Period** in the **Entry Level** field and then press **Enter** on the **Maintain Seasonal Indices Selection** window.

This window displays the daily indices at the top of the window, and a box containing the period indices.

Use this window to create a distribution pattern, which can be used, when you generate an [MPS](#) forecast, to spread the forecast quantities over the appropriate days, weeks and periods of the [planning horizon](#).

Enter a number in the **Index** field for each period over which you want to spread your forecast quantities. Use higher numbers to represent periods in which you want to produce the most goods. When you select **Display Distribution (F18)**, the software will express these indices as percentages. The total will always add up to 100%.

If you enter numbers in the **Daily Indices** fields, the forecast quantities for each week will be spread over the week according to these indices. If you leave these fields blank, the weekly forecast quantities will be spread evenly over the days of the week.

Fields

Description (Untitled)

Enter a suitable description for the profile.

Daily Indices

Enter daily indices as appropriate.

Index

Enter period indices as appropriate.

Functions

Period Indices (F16)

This is displayed after you have selected **Weekly Indices (F17)**. Use this to move the cursor from the **Weekly Indices** table to the **Period Indices** table.

Weekly Indices (F17)

It is possible to display weekly periods, within months. Use this to display the **Weekly Indices** table, in which you can enter the weekly indices.

Display Distribution (F18)

Use this to see the percentage distribution for the indices you have entered.

Select **Update (F8)** to update your entries and return to the **Maintain Seasonal Indices Selection** window.

Maintain Seasonal Indices Week Window

To display this window, select **Weekly** in the Entry Level field and then press Enter on the Maintain Seasonal Indices Selection window.

This window displays the daily indices at the top of the window and a table containing the week indices.

Use this window to create a distribution pattern, which may be used when you generate an [MPS](#) forecast, to spread the forecast quantities over the appropriate days, weeks and periods of the [planning horizon](#).

Enter a number in the Index field for each week over which you want to spread your forecast quantities. Use higher numbers to represent weeks in which you want to produce the most goods. When you select **Display Distribution (F19)**, the software will express these indices as percentages. The total will always add up to 100%.

If you enter numbers in the Daily Indices fields, the forecast quantities for each week will be spread over the week according to these indices. If you leave these fields, blank the weekly forecast quantities will be spread evenly over the days of the week.

Fields

Index

Enter week indices as appropriate.

Functions

Display Distribution (F19)

Use this to display the percentage distribution for the indices you have entered.

Select **Update (F8)** to update your entries and return to the Maintain Seasonal Indices Selection window.

Maintain Seasonal Indices Period & Week Window

To display this window, select **Weekly Indices (F17)** on the Maintain Seasonal Indices Period window.

This window displays the daily indices at the top of the window and tables containing the period and weekly indices.

Use this window to create a distribution pattern, which can be used when you generate an [MPS](#) forecast, to spread the forecast quantities over the appropriate days, weeks and periods of the [planning horizon](#).

Enter a number in the Index field for each week over which you want to spread your forecast quantities. Use higher numbers to represent weeks in which you want to produce the most goods. When you select **Display Distribution (F18)**, the software will express these indices as percentages. The total will always add up to 100%.

If you enter numbers in the Daily Indices fields, the forecast quantities for each week will be spread over the week according to these indices. If you leave these fields, blank the weekly forecast quantities will be spread evenly over the days of the week.

Fields

Index

Enter indices as appropriate.

Functions

Period Indices (F16)

Use this to move the cursor from the Weekly Indices table to the Period Indices table.

Weekly Indices (F16)

Use this to move the cursor from the Period Indices table to the Weekly Indices table.

Display Distribution (F19)

Use this to display the percentage distribution for the indices you have entered.

Select **Update (F8)** to update your entries and return to the Maintain Seasonal Indices Selection window.

Copy Forecast Model [3/MPF]

Use this task to copy forecasts from one planning unit or model to another. You can use this in both a multi-plant and non-multi-plant environment. Multi-plant is used here as a term that covers multi-plant, multi-sourcing and [cellular planning](#).

Note: Before you can use multi-plant, multi-sourcing and [cellular planning](#), you must activate them in the [company profile](#).

Note: [Cellular planning](#) is currently unavailable for [MPS](#).

Copy Model Definition Window

To display this window, select the Copy Forecast Model task.

You use this window to:

- Enter the model to which you want to copy
- Enter the model from which you want to copy
- Specify the forecast details you want to copy to the target model

Fields

Model

Enter the [organisational model](#) whose forecasts are to be replaced.

Alternatively, use the prompt facility to select from the Select Model pop-up.

Based On

Enter the [organisational model](#) whose forecast details will be copied.

Alternatively, use the prompt facility to select from the Select Model pop-up.

Replace Options

Use these checkboxes as follows:

Unchecked - Not replace the selected detail in the target model with the data from the Based On model

Checked - To replace the selected detail in the target model with the data from the Based On model

You can replace:

- Stockroom definition
- Reporting profile
- Family profile
- Family forecasts
- Item forecasts

You must make at least one selection.

Complete the required entries and then press Enter. Select **Copy (F8)** to copy the forecast details and leave the task.

Maintain Family Sales Forecast & Maintain Family Stock Forecast [11/MPF, 21/MPF]

When you have created a [product family](#), you can use these tasks to enter details of the weekly forecasts for the family. The quantities or values you enter in the forecasts are for the [product family](#) as a whole. These are apportioned to the items in the [product family](#) according to the percentages [set up](#) in the Maintain [Product Family](#) task.

You can [set up](#) two types of family forecast:

- Sales Forecast

Sales forecasts are statements of anticipated market demand for a product. During the planning process, these are compared with any existing sales orders, and then, in accordance with the demand policy for the item, which tells the software how to compare the forecast and sales orders, the net demand is determined.

- Stock Forecast

Stock forecasts are statements of the required build of products to meet customer service objectives, and represent a hedge against demand uncertainty. They are not consumed by sales orders, and should be viewed as orders to replenish stock. The items produced to satisfy a stock forecast are intended to be used as hedging inventory, or as customer service inventory. You should use this demand management technique carefully to avoid building excessive levels of inventory. It is a means of buffering demand uncertainty in the marketplace.

Differences between Sales and Stock Forecasting

As the sale and [stock forecast](#) maintenance facilities are very similar, it is important to understand the following distinction:

- A sales forecast is a quantity of demand to be met within a period of time.
- A stock forecast is a target level to be maintained during that period of time. The stock target over intervals figure represents the stock level to be achieved across the selected intervals.

For example, a [sales forecast](#) representing a market [demand](#) of 3,000 spread evenly over three periods potentially leads to production of 1,000 in each period. A [stock forecast](#) intended to maintain a stock level of 3,000 for three periods shows the 3,000 target in each of the three periods.

Seasonal Profiles

A [seasonal profile](#) is [set up](#) to act as a template when entering forecasts. If you enter a profile code, forecast values are apportioned automatically according to the rules defined for it.

This entry also determines the level to which the forecast may be maintained. If the [seasonal profile](#) has a weekly entry level, you can only have daily and weekly interval selections.

If the forecast is on a weekly basis and you have [set up](#) daily indices the forecast quantities for each week will be spread over the week according to these indices.

Note: To use these daily indices, you must enter the [seasonal profile](#) and check the *Maintain Intervals* field on the *Maintain Family Forecast Selection* window.

Maintain Family Forecast Selection Window

To display this window, select the Maintain Family [Sales Forecast](#) task or the Maintain Family [Stock Forecast](#) task.

You use this window to enter the criteria for the family forecast you want to maintain. The title of the window will depend on the task you have selected.

Fields

Model

Enter the [organisational model](#).

Alternatively, use the prompt facility to select from the Select Model pop-up.

Year

Enter the calendar year over which you are forecasting. The default is the current year.

Product Family

Enter the [product family](#) for which you want to maintain this forecast.

Alternatively, use the prompt facility to select from the Select [Product Family](#) pop-up.

Forecast Basis

Select one of the following:

Quantity (1) (default) - To forecast by quantity

Value (2) - To forecast by value

A forecast expressed in value terms is converted to a forecast quantity. A sales value forecast is divided by the base list price held on the Item Master file. A stock value forecast is divided by the standard [cost](#) of the item in its [primary stockroom](#).

Seasonal Profile

You can enter a [seasonal profile](#), if you have previously set it up.

If you leave this field blank, the values you have entered for the forecast are evenly spread, and any manipulation must be done manually.

If you enter an existing [seasonal profile](#), the profile, year, model and calendar combination must already exist.

You can use the prompt facility on this field to select from the Select Seasonal Index pop-up.

Note: If you use a [seasonal profile](#) when maintaining [stock forecasts](#), then the highest index figure is used to assign the stock target total. It then assigns the other index values in proportion. If you do not use a [seasonal profile](#), you must enter the stock target in each period.

Maintain Intervals

Use this checkbox as follows:

Unchecked - Not to maintain intervals

Checked - If you want to select which periods require a daily forecast and which require a weekly or period forecast

Include Backlog

Unchecked - Not to include backlog

Checked - To include any outstanding sales orders due within the run dates of the last [MRP](#) run for the selected forecast model

Note: This field is only displayed for [sales forecasts](#).

Press Enter to display the next window, which will depend on the setting of the Maintain Intervals field.

Maintain Family Forecast Spread Window

To display this window, check the Maintain Intervals field and then press Enter on the Maintain Family Forecast Selection window.

You use this window if you want to spread all or part of the forecast over a particular interval in the forecast.

If you select daily forecasts for a range of week numbers, the software spreads the forecast daily over the indicated weeks, regardless of the [seasonal profile](#) setting.

Note: *The week numbers you enter for the respective forecast intervals must be consistent and fall on period boundaries.*

Fields

Forecast Quantity/Value to Spread

Enter the quantity or value of the forecast that you would like to spread over daily, weekly or period forecasts. Leave this field blank to use the total forecast quantity or value.

Note: *This field is only displayed for [sales forecasts](#).*

Stock Target Quantity

Enter the quantity or value of the forecast that you would like to spread over daily, weekly or period forecasts. Leave this field blank to use the total forecast quantity or value.

Note: *This field is only displayed for [stock forecasts](#).*

Daily Forecasts From Week/To Week

If you want to spread a portion of the forecast on a daily basis, enter the week numbers over which you want the daily forecast spread.

Weekly Forecasts From Week/To Week

If you want to spread a portion of the forecast on a weekly basis, enter the week numbers over which you want the weekly forecast spread.

Period Forecasts From Week/To Week

If you want to spread a portion of the forecast on a period basis, enter the week numbers over which you want the period forecast spread.

Functions

Build Forecast (F10)

Use this to build the forecast for the required interval, if you receive a warning that intervals overlap.

Note: *If there is already an established forecast for this model and [product family](#) within the entered interval set, the software warns you if the new forecast will overlap the existing one.*

Display Structure (F20)

Use this to display the Calendar Structure window. A table is displayed, showing the structure of the calendar you are using.

Press Enter to display the Maintain Family Forecast Details window. You must first enter the details for at least one interval set.

Calendar Structure Window

To display this pop-up, select **Display Structure (F20)** on the Maintain Family Forecast Spread window.

Alternatively, select **Display Structure (F20)** on the Maintain Item Forecast Spread window.

You can use this window to view the structure of the calendar you are using. It displays the periods that are [set up](#) in the calendar and the week on which each period starts and ends. This is useful as a reference when you are setting up family or item forecasts, as the week numbers you enter for the forecast intervals must fall on period boundaries.

Note: *You cannot remove the table once you have displayed it, but you can still enter values on the Maintain Family Forecast Spread window and the Maintain Item Forecast Spread window.*

Press Enter to display the Maintain Family Forecast Details window. You must first enter the details for at least one interval set.

Maintain Family Forecast Details Window

To display this window, press Enter on the Maintain Family Forecast Selection window or the Maintain Family Forecast Spread window or the Calendar Structure window.

Use this window to enter the forecast quantities or values and their associated indices. Details displayed on this window include:

- The sum of all the forecast quantities or values that you enter
This total is re-calculated every time you press Enter.
- The sum of the indices for all forecast quantities or values
This is only used for sales forecasts.
- For daily and weekly forecasts, the period and week number
This is displayed in the form PPWW, where PP is the period number and WW is the week number.
- For period forecasts, the period number
This is displayed in the form PP, where PP is the period number.
- The start date for each forecast week

Note: *If you do not use a [seasonal profile](#), or the profile has no daily indices [set up](#), the weekly template of working and non working days in the [company profile](#) will be used to distribute the quantities over the daily forecast.*

Fields

Total Forecast Quantity/Value

This field displays the total to be forecast. This is brought forward from the Maintain Family Forecast Spread window, but you can change it here.

Note: This field is only displayed for [sales forecasts](#).

Stock Target Quantity

This field displays the total to be forecast. This is brought forward from the Maintain Family Forecast Spread window, but you can change it here.

Note: This field is only displayed for [stock forecasts](#).

Position to Period

Enter the period number to advance the display to the forecast for that period.

Index

This field displays the index value for each forecast period. Enter the indices you will use to spread the total forecast figure over the forecast days, weeks or periods. If you are using a [seasonal profile](#), the indices from the profile will be entered automatically.

Quantity/Value

If you set the Forecast Basis field on the Maintain Family Forecast Selection window to Quantity, these fields will display forecast quantities. If you set the Forecast Basis field on the Maintain Family Forecast Selection window to Value, these fields will display forecast values.

You can enter the forecast quantities or values manually, or enter the indices and then select **Apply Index (F17)**. The software will then calculate the forecast quantities or values from the total spread over the indices.

Options

Select to Spread

This is only [available](#) for period and weekly forecasts.

Use this against a forecast line to display more spread details.

If the forecast is weekly, the Daily Spread pop-up is displayed, where you can specify how the forecast is spread over the days of the week.

If the forecast is for a period, the Weekly Spread pop-up is displayed, where you can specify how the forecast is spread over the weeks of the period.

Functions

Barchart (F14)

Use this to display a bar chart of the forecast quantities. Select **Previous (F12)** to return to this window.

Apply Index (F17)

Use this to re-calculate the distribution when changes have been made to indices or forecast quantities.

Create or Update/Item Forecasts (F20)

Use this to display and access the forecast percentage for individual members of the [product family](#).

Stock Profile (F22)

Use this to display the Stock Level Profile pop-up.

Note: This field is only displayed for [stock forecasts](#).

Select **Update (F8)** to update and confirm your forecast and return to the previous window.

Daily Spread Pop-up

To display this pop-up, use Select to Spread against a forecast week on the Maintain Family Forecast Details window or on the Weekly Spread pop-up.

You use this pop-up to create a more detailed spread for the selected forecast.

This pop-up is displayed if the forecast is weekly. You can edit how the forecast is spread over the days of the week.

Fields**Week Total**

This field displays the total quantity or value for the forecast week. This is brought forward from the Maintain Family Forecast Details window, but you can change it here.

Index

This displays the index value for each forecast day. Enter the indices you will use to spread the total forecast figure over the forecast days. If you are using a [seasonal profile](#), the indices from the profile will be entered automatically.

Quantity/Value

If you set the Forecast Basis field on the Maintain Family Forecast Selection window to Quantity, these fields will display forecast quantities. If you set the Forecast Basis field on the Maintain Family Forecast Selection window to Value, these fields will display forecast values.

You can enter the forecast quantities or values manually, or enter the indices and then select **Apply Index (F17)**. The software will then calculate the forecast quantities or values from the total spread over the indices.

Functions

Apply Index (F17)

Use this to re-calculate the distribution when changes have been made to indices or forecast quantities.

Press Enter to update the forecast and return to the Maintain Family Forecast Details window.

Weekly Spread Pop-up

To display this pop-up, use Select to Spread against a forecast period and then press Enter on the Maintain Family Forecast Details window.

You use this pop-up to create a more detailed spread for the selected forecast.

This pop-up is displayed if the forecast is for a period. You can edit how the forecast is spread over the week of the period.

Fields

Total Quantity

This field displays the total quantity or value for the forecast period. This is brought forward from the Maintain Family Forecast Details window, but you can change it here.

Seasonal Profile

This field displays the [seasonal profile](#) specified on the Maintain Family Forecast Selection window.

Note: You can change the [seasonal profile](#) here, but this will change the overall forecast for the item.

You can use the prompt facility on this field to select from the Select Seasonal Index pop-up.

Index

This field displays the index value for each forecast week. Enter the indices you will use to spread the total forecast figure over the forecast weeks. If you are using a [seasonal profile](#), the indices from the profile will be entered automatically.

Quantity/Value

If you set the Forecast Basis field on the Maintain Family Forecast Selection window to Quantity, these fields will display forecast quantities. If you set the Forecast Basis field on the Maintain Family Forecast Selection window to Value, these fields will display forecast values.

You can enter the forecast quantities or values manually, or enter the indices and then select **Apply Index (F17)**. The software will then calculate the forecast quantities or values from the total spread over the indices.

Options

Select to Spread

Use this against the week for which you want to create a daily spread. This will display the Daily Spread pop-up, where you can create the daily spread. This daily spread is then transferred to the Maintain Family Forecast window.

Caution: If you use this facility to create a daily spread you cannot select it for maintenance again on the Maintain Family Forecast window.

Functions

Apply Index (F17)

Use this to re-calculate the distribution when changes have been made to indices or forecast quantities.

Press Enter to update the forecast and return to the Maintain Family Forecast Details window.

Select Item Pop-up

To display this pop-up, select **Create** or **Update/Item Forecasts (F20)** on the Maintain Family Forecast Details window.

You use this pop-up to select the forecast for an individual item for maintenance. Forecasts are apportioned to the items in a [product family](#) according to the percentages you [set up](#) in the Maintain [Product Family](#) task.

Fields

Position To

You can enter a character in this field to position the display to that place in the item list.

Options

Select

Use this against the item for which you want to maintain the forecast

Select an item to display the Maintain Family Forecast Details window, with the forecast for that item displayed.

Stock Level Profile Pop-up

To display this pop-up, select **Stock Profile (F22)** on the Maintain Family Forecast Details window.

Use this pop-up to build a stock profile. Based on the dates and quantity you enter, a [stock forecast](#) will then be generated to meet the profile. All quantity and value figures will be re-calculated.

Note: This function is only [available](#) for a [stock forecast](#).

Note: You can build a stock profile over more than one forecast year by defining the same four parameters over consecutive years.

Fields

From Date/To Date

Enter or select the date range over which the forecast is built.

Target Date

Enter or select the date at which the target stock level should be achieved.

Target Quantity/Value

Enter the stock level that should be achieved at the target date.

Press Enter to re-display the Maintain Family Forecast Details window, with the quantities that are required to achieve the target stock level calculated for each period.

Generate Item Sales Forecast & Generate Item Stock Forecast [12/MPF, 22/MPF]

Use this task to create a forecast for each item in a [product family](#) from the [product family](#) forecast. The forecast is generated according to the proportions defined in the Maintain [Product Family](#) task. This creates detailed item level forecasts.

Note: This task is not relevant unless you are using product families for forecasting. Do not use this task if you are forecasting using the Maintain Item Forecast task.

You can use the Maintain Item Forecast task to fine-tune the individual forecasts before running [MPS](#).

Generate Item Forecast Selection Window

To display this window, select the Generate Item [Sales Forecast](#) task or the Generate Item [Stock Forecast](#) task.

You use this window to enter the criteria for the item forecast you want to generate.

Fields

Model

Enter the model for which you are building a forecast.

Alternatively, use the prompt facility to select from the Select Model pop-up.

Year

Enter the year for which the forecast is being built.

Family

Select the range of [product family](#) groups to be displayed for selection on the next window. If you leave these fields blank, all product families within the model are displayed.

You can use the prompt facility on these fields to select from the PGMN - [Item Group Minor](#) pop-up.

Note: *This process re-calculates any existing [sales forecast](#) for the items in the selected families.*

Press Enter to display the Generate Item Sales Forecast Families window.

Generate Item Forecast Window

To display this window, press Enter on the Generate Item Forecast Selection window.

You use this window to select the product families for which you want to generate item forecasts.

Fields

Select (Sel)

Use these checkboxes as follows:

Unchecked - To omit product families from the forecast generation

Checked - To include product families in the forecast generation

Select **Submit Job (F8)** to submit the job to generate the forecasts and leave the task.

Maintain Item Sales Forecast & Maintain Item Stock Forecast [13/MPF, 23/MPF]

Use this task to:

- Fine tune the forecasts created with the Generate Item Sales Forecast or Generate Item Stock Forecast tasks
- Enter individual item forecasts as required

In any one family, individual items can have different peak periods for production. You can use this task to maintain these differences.

You can also change total quantities. However, if they are part of a previously defined family total, this may well be invalidated by this action.

Maintain Item Forecast Selection Window

To display this window, select the Maintain Item [Sales Forecast](#) task or the Maintain Item [Stock Forecast](#) task.

You use this window enter the criteria for the item forecast you want to maintain.

Fields

Model

Enter an [MPS](#) model for the forecast. If you intend to run [MPS](#) using this forecast and then want to confirm any suggested [supply](#), the model you enter here must be the live model, as defined on the [company profile](#).

You can use the prompt facility on this field to select from the Select Model pop-up.

Year

Enter the calendar year for which you are forecasting. The model and year combination must exist on the company calendar. The default is the current system year.

Item

Enter a valid item. The item must exist and have a non-zero [demand policy](#).

You can use the prompt facility on this field to select from the Select Item pop-up.

Forecast Basis

Select one of the following:

Quantity (1) (default) - To express the forecast in quantities

Value (2) - To express the forecast in values

A forecast expressed in values is converted to a forecast quantity by this process. A sales value forecast is divided by the base list price held in the Item Master file. A stock value forecast is divided by the standard [cost](#) of the item in its [primary stockroom](#).

Seasonal Profile

You can enter a [seasonal profile](#), if you have previously set it up.

If you leave this field blank, the values you have entered for the forecast are evenly spread, and any manipulation must be actioned manually.

If you enter an existing [seasonal profile](#), the profile, year, model and calendar combination must already exist.

You can use the prompt facility on this field to select from the Select Seasonal Index pop-up.

Maintain Intervals

Use this checkbox as follows:

Unchecked - Not to maintain intervals

Checked - If you want to select which periods require a daily forecast and which require a weekly or period forecast

Check this field to spread the quantity or value over selected intervals. This displays a separate window where you can specify the total forecast quantity or value with which you want to work.

You then specify how you want to present the time [buckets](#) on the forecast window. You can specify either daily or weekly time [buckets](#).

It is usual to select daily intervals for the earliest week or weeks in the forecast, weekly intervals for intermediate weeks, and periods for the longer-term part of the forecast.

Period [buckets](#) are not allowed if the selected profile is weekly-based, and does not use periods itself.

Include Backlog

Use this checkbox as follows:

Unchecked - Not to include backlog

Checked - To display the outstanding sales orders due within the run dates of the last [MRP](#) run for the forecast model selected

Note: *This field is only displayed for [sales forecasts](#).*

Press Enter to display the Maintain Item Forecasts Spread window.

Maintain Item Forecast Spread Window

To display this window, check the Maintain Intervals field and then press Enter on the Maintain Item Forecast Selection window.

You use this window if you want to spread all or part of the forecast over a particular interval in the forecast.

If you select daily forecasts for a range of week numbers, the software spreads the forecast daily over the indicated weeks, regardless of the [seasonal profile](#) setting.

Note: *The week numbers you enter for the respective forecast intervals must be consistent and fall on period boundaries.*

Fields

Forecast Quantity/Value to Spread

Enter the quantity or value of the forecast that you would like to spread over daily, weekly or period forecasts. Leave this field blank to use the total forecast quantity or value.

Note: *This field is only displayed for [sales forecasts](#).*

Stock Target Quantity

Enter the quantity or value of the forecast that you would like to spread over daily, weekly or period forecasts. Leave this field blank to use the total forecast quantity or value.

Note: *This field is only displayed for [stock forecasts](#).*

Daily Forecasts From Week/To Week

If you want to spread a portion of the forecast on a daily basis, enter the week numbers over which you want the daily forecast spread.

Weekly Forecasts From Week/To Week

If you want to spread a portion of the forecast on a weekly basis, enter the week numbers over which you want the weekly forecast spread.

Period Forecasts From Week/To Week

If you want to spread a portion of the forecast on a period basis, enter the week numbers over which you want the period forecast spread.

Functions

Build Forecast (F10)

Use this to build the forecast for the required interval, if you receive a warning that intervals overlap.

Note: *If there is already an established forecast for this model and item within the entered interval set, the software warns you if the new forecast will overlap the existing one.*

Display Structure (F20)

Use this to display the Calendar Structure pop-up, which you can use to view the structure of the calendar you are using.

Press Enter to display the Maintain Item Forecast Details window. You must first enter the details for at least one interval set.

Maintain Item Forecasts Details Window

To display this window, press Enter on either the Maintain Item Forecast Selection window or the Maintain Item Forecast Spread window.

Use this window to enter the forecast quantities or values and their associated indices. Details displayed on this window include:

This is displayed in the form PPWW, where PP is the period number and WW is the week number.

- For period forecasts, the period number
This is displayed in the form PP, where PP is the period number.
- The start date for each forecast week

Note: *If you do not use a [seasonal profile](#), or the profile has no daily indices [set up](#), the weekly template of working and non-working days in the [company profile](#) will be used to distribute the quantities over the daily forecast.*

Fields

Total Forecast Quantity/Value

This field displays the total to be forecast. This is brought forward from the Maintain Item Forecast Spread window, but you can change it here.

Note: This field is only displayed for [sales forecasts](#).

Stock Target Quantity

This field displays the total to be forecast. This is brought forward from the Maintain Item Forecast Spread window, but you can change it here.

Note: This field is only displayed for [stock forecasts](#).

Position to Period

Enter the period number to advance the display to the forecast for that period.

Index

This field displays the index value for each forecast period. Enter the indices you will use to spread the total forecast figure over the forecast days, weeks or periods. If you are using a [seasonal profile](#), the indices from the profile will be entered automatically.

Quantity, Value

If you set the Forecast Basis field on the Maintain Item Forecast Selection window to Quantity, these fields will display forecast quantities. If you set the Forecast Basis field on the Maintain Item Forecast Selection window to Value, these fields will display forecast values.

You can enter the forecast quantities or values manually, or enter the indices and then select **Apply Index (F17)**. The software will then calculate the forecast quantities or values from the total spread over the indices.

Options**Select to Spread**

This is only displayed for period and weekly forecasts.

Use this against a forecast line to display more spread details.

If the forecast is weekly, the Daily Spread pop-up is displayed, where you can specify how the forecast is spread over the days of the week.

If the forecast is for a period, the Weekly Spread pop-up is displayed, where you can specify how the forecast is spread over the weeks of the period.

Functions**Barchart (F14)**

Use this to display a bar chart of the forecast quantities. Select **Previous (F12)** to return to this window.

Apply Index (F17)

Use this to re-calculate the distribution when changes have been made to indices or forecast quantities.

Display Values (F18)

Use this to toggle between displaying the forecast quantities and forecast values. The forecast value is the Base List Price multiplied by the Quantity.

For details on the other fields and functions on this window, refer to the Maintain Family [Sales Forecast](#) section.

Stock Profile (F22)

Use this to display the Stock Level Profile pop-up.

This is only displayed for item [stock forecasts](#).

Select **Update (F8)** to update and confirm your forecast, and return to the previous window.

Daily Spread Pop-up

To display this pop-up, use Select to Spread against a forecast week on the Maintain Item Forecast Details window.

You use this pop-up to create a more detailed spread for the selected forecast.

This pop-up is displayed if the forecast is weekly. You can edit how the forecast is spread over the days of the week.

Fields

Week Total

This field displays the total quantity or value for the forecast week. This is brought forward from the Maintain Family Forecast Details window, but you can change it here.

Index

This displays the index value for each forecast day. Enter the indices you will use to spread the total forecast figure over the forecast days. If you are using a [seasonal profile](#), the indices from the profile will be entered automatically.

Quantity, Value

If you set the Forecast Basis field on the Maintain Family Forecast Selection window to Quantity, these fields will display forecast quantities. If you set the Forecast Basis field on the Maintain Family Forecast Selection window to Value, these fields will display forecast values.

You can enter the forecast quantities or values manually, or enter the indices and then select **Apply Index (F17)**. The software will then calculate the forecast quantities or values from the total spread over the indices.

Functions

Apply Index (F17)

Use this to re-calculate the distribution when changes have been made to indices or forecast quantities.

Press Enter to update the forecast and return to the Maintain Item Forecast Details window.

Weekly Spread Pop-up

To display this pop-up, use Select to Spread against a forecast period on the Maintain Item Forecast Details window.

You use this pop-up to create a more detailed spread for the selected forecast.

This pop-up is displayed if the forecast is weekly. You can edit how the forecast is spread over the days of the week.

Fields

Quantity/Value

If you set the Forecast Basis field on the Maintain Item Forecast Selection window to Quantity, these fields will display forecast quantities. If you set the Forecast Basis field on the Maintain Item Forecast Selection window to Value, these fields will display forecast values.

You can enter the forecast quantities or values manually, or enter the indices and then select **Apply Index (F17)**. The software will then calculate the forecast quantities or values from the total spread over the indices.

Options

Select to Spread

Use this to select the week for which you want to create a daily spread. Press Enter to display the Daily Spread pop-up where you can create the daily spread. This daily spread is then transferred to the Maintain Family Forecast window.

Caution: If you use this facility to create a daily spread you cannot select it for maintenance again on the Maintain Family Forecast window.

Functions

Apply Index (F17)

Use this to re-calculate the distribution when changes have been made to indices or forecast quantities.

Press Enter to update the forecast and return to the Maintain Item Forecast Details window.

Stock Level Profile Pop-up

To display this pop-up, select **Stock Profile (F22)** on the Maintain Item Forecast Details window.

Use this pop-up to build a stock profile. Based on the dates and quantity you enter, a [stock forecast](#) will then be generated to meet the profile. All quantity and value figures will be re-calculated.

Note: This is only [available](#) for [stock forecasts](#).

Note: You can build a stock profile over more than one forecast year by defining the same four parameters over consecutive years.

Fields

From Date

Enter or select the date from which the stock profile will be built.

To Date

Enter or select the date to which the stock profile will be built.

Target Date

Enter or select the date at which the target stock level should be achieved.

Target Quantity

Enter the stock level that should be achieved at the target date.

Press Enter to return to the Maintain Item Forecast Details window, with the quantities required to achieve the target stock level calculated for each period.

Spread Item Sales Forecast & Spread Item Stock Forecast [14/MPF, 24/MPF]

Use these tasks to:

- Select the sales forecast for one or more items for spreading, according to intervals that you specify here
You must enter at least one set of intervals, and the intervals must be adjoined to each other.
- Change the default seasonal profile for the item, as defined in the item's production details

Spread Item Forecast Selection Window

To display this window, select the Spread Item [Sales Forecast](#) task or the Spread Item [Stock Forecast](#) task.

You use this window to enter the criteria for the item forecast you want to spread.

Fields

Model

Enter an [MPS](#) model for the forecast.

Alternatively, use the prompt facility to select from the Select Model pop-up.

Year

Enter the calendar year over which you are forecasting. The model and year combination must exist on the company calendar. The default is the current system year.

Product Family

Enter a valid [product family](#) code here. It must be consistent with the items that you enter in the From and To Item fields.

You can use the prompt facility on this field to select from the Select [Product Family](#) pop-up.

From Item

Enter the first item in the range for which you want to spread forecasts. Leave this field blank for all items.

You can use the prompt facility on this field to select from the Select Item pop-up.

To Item

Enter the last item in the range for which you want to spread forecasts. Leave this field blank for all items.

You can use the prompt facility on this field to select from the Select Item pop-up.

Forecast Basis

Select one of the following:

Quantity (1) (default) - To express the forecast in quantities

Value (2) - To express the forecast in values

Press Enter to display the Spread Item [Sales Forecast](#) Details window.

Spread Item Forecast Details Window

To display this window, press Enter on the Spread Item Forecast Selection window.

This window displays the items selected on the previous window.

You use this window to:

- Select the items for which you want to spread the forecast
- Enter the weeks for which you want to create daily forecasts
- Enter the weeks for which you want to create weekly forecasts

Fields**Select (Untitled)**

Use these checkboxes as follows:

Unchecked - Not to spread the forecast for that item

Checked - To spread the forecast for that item

Seasonal Profile

If a [seasonal profile](#) has been used for the forecast for the item, it is displayed here. It will define the spread of the quantities over the selected intervals. You can change or delete it here.

Daily Forecasts From Week/To Week

Enter the range of week numbers for which the daily forecasts are required.

Weekly Forecasts From Week/To Week

Enter the range of week numbers for which the weekly forecasts are required.

Functions**Select All (F15)**

Use this to select the forecasts for all the items for spreading.

Display Values (F18)

Use this to toggle between displaying the forecast values and quantities.

Select the required items and then select **Submit Job (F8)** to submit the job for processing and leave the task.

About MPS Processing

You must carry out certain maintenance tasks before running [MPS](#). After the run, you can use enquiries and reports to determine the feasibility of the model.

Selective exclusivity checking is possible for submitting and running [MPS](#) planning runs. Rather than preventing access to all tasks in OE, AO, PM, and AC, it is possible to make selections that will control access on a function-by-function basis. For example, database update functions such as Order Maintenance could be prevented from running, but most enquiries and reports could still be [available](#) as normal, by setting the selections. The level of exclusivity is set in Application Manager.

The stages in [MPS](#) processing can be summarised as follows:

- Run the Maintain MPS Reporting Profile task (you only need to do this once)
- Run the Maintain MPS Model Stockroom task (you only need to do this once)
- Run the Generate Model Primary Stockrooms task (if you are using multi-plant)
- Run the Maintain Supply Sourcing Rules task (if you are using multi-sourcing)
- Run the Maintain Model Planning Sequence (if you are using multi-plant)
- Maintain Rough Cut Capacity Planning routes
- Run the Maintain Seasonal Indices task *
- Run the Maintain Product Family task *
- Run the Maintain Family Forecast task (this is optional) *
- Run the Generate Item Forecast task (if you are using family forecasts) *
- Run the Spread Item Forecast task (this is optional) *
- Run the Maintain Item Forecast task (this is optional)*
- Run the MPS Automatic Run Parameters task
- Run the Run MPS task (with optional interrupt after demand extraction)
- Run the Review Demand task and make required changes (if MPS interrupt is used)
- Run the Resume MPS task (if MPS interrupt is used)
- Run the Run Rough Cut Capacity Plan task
- Make enquiries and run reports
- Execute MPS suggested changes to orders and schedules
- Run the Confirm MPS Suggested Orders and Confirm MPS Suggested Schedules tasks

- * If you use [MPS](#) forecasting

Items Included in the MPS Run

The following items are included in the [MPS](#) run:

- MPS items with a level code in the structure, lower than or equal to the cut-off level for the run, and are defined in a stockroom included in the model
- MPS items not in the model but with dependent MPS items that meet the above criteria
- Non-MPS items with dependent MPS items that meet the above criteria

Item Schedule Relief

[Item schedule](#) relief allows actual quantities and times to be relieved against an [item schedule](#), thereby allowing outstanding [balances](#) to be shown. The quantity booked is held against the [item schedule](#) and is used in the planning cycle to reflect the latest requirement:

Outstanding quantity = Existing planned quantity - Total booked quantities, that is, good + held + scrapped

If the [item schedule](#) has been fully satisfied through [booking](#), then it will not be extracted during the planning run.

Structure Checks

All planning item structures are analysed and [low level codes](#) assigned to every item that is defined to Production. This is important, as items must not be reviewed until all possible [dependent demand](#) has been generated.

If you have made no changes to structures since the last MPS run, you do not need to re-calculate the low-level codes. This is indicated by the flag Suppress Low Level Code Generation defaulting to **checked** in the Run MPS task.

The system also checks the structure and produces an exception report for all invalid parent [input](#) combinations. These are called recursive structures.

For example:

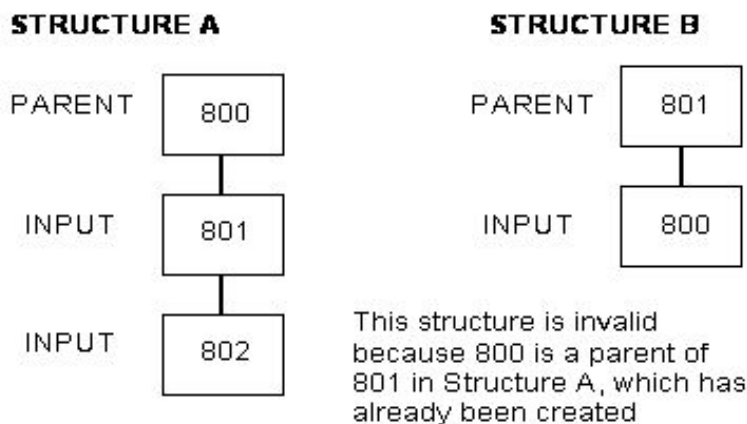

MPS Run Options

You can set the [MPS](#) run so that it runs to completion as one [operation](#), or stops part way through for you to manipulate [demand](#) manually. Once changed, you must re-start the [MPS](#) run.

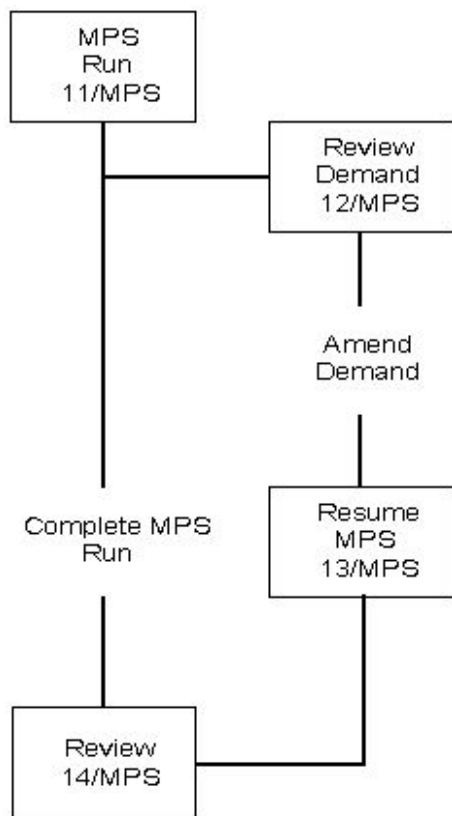

All production planning is specific to a [planning model](#). One live [planning model](#) must be created from which suggested orders can be confirmed and, in the case of [MPS](#), [output](#) used as [input](#) to [MRP](#).

Sales Production and Purchase Order Selection

Sales orders are selected for inclusion in the [MPS](#) run if:

- The order status is blank.
- The Order Entry Suspense Code is not included in the Manufacturing parameter OEIG.
- An outstanding quantity is present.
- The due date is within the MPS run dates.
- The warehouse or depot location is defined to the MPS model.

Production orders are included, if:

- The due date is within the MPS run dates.
- The receiving stockroom is defined to the MPS model. If the stockroom is not in the model, the components on each order are examined according to the above criteria, to see if they should be included in the run.

- There is an outstanding supply quantity, defined as order quantity minus quantity complete.

Note: The [component](#) quantity on existing orders is calculated as quantity required minus quantity issued to the order.

The MPS run also includes purchase orders with an outstanding quantity of items considered by [MPS](#). The outstanding quantity on these orders is taken from Purchase Management or Inventory Management. If the order has an expected date, this is used instead of the due date on the order.

DRP Transfer Orders

The [MPS](#) extract considers [DRP](#) transfer orders as both [demand](#) and [supply](#). Where they are considered as [supply](#), they consider any reserved quantity as unavailable.

Where the Demand and Supply are in different Plants, but both within the same Central Model, a single Transfer Order may be both a Supply in the Receiving Stockroom's Plant Model, and a Demand in the Sending Stockroom's Plant Model. The reserved quantities are considered separately in each Plant, depending on which plant(s) the reservation applies to.

Available Stock When the Required Route Does Not Exist

If the [MPS](#) processing finds no method for manufacturing an Item, it makes a suggestion using SS ([Schedule](#)) or SW (Work Order) that a [supply](#) should be created for the quantity required, using the [planning route](#) of the Item.

Use of the Manufacturing parameter code PLRP stops the planning run from writing the [supply](#) record for an SS or SW type [supply](#), if the [route](#) suggested is not defined. However, the calculation that nets [supply](#) and [demand](#) continues as if the [supply](#) had in fact been created. This allows the planning process to carry on as normal. When the results are subsequently viewed through, for example, [MPS](#) Review, it is apparent that there is [demand](#) that has not been satisfied. This can also be seen by using the Report by [Supply/Demand Variance](#) task after the run.

This can be particularly useful in a co-product context, where there may be products that are only produced as secondary products, as a result of satisfying the [demand](#) for the primary products. In this case, there may be remaining unsatisfied [demand](#) for the secondary products, where there is no method for [supplying](#) them in their own right. With this parameter set, the planning systems will no longer make [supply](#) suggestions based on the products' [planning routes](#), so that the planning review will clearly show that there is unsatisfied [demand](#).

MPS Review - Firm Planned Supplies

A firm planned [supply](#) is taken to mean a planned [supply](#) that is frozen by the [planner](#) in terms of its quantity and timing. The planning algorithm does not automatically change such a [supply](#), as this is the task of the [planner](#). However, [MPS](#) will indicate in the enquiry and report any suggested changes to its [supply](#) quantity. This is to ensure the required inventory service level is maintained, but these suggested changes are not included in the subsequent calculations of either inventory availability or dependent material requirements, where the firm quantity and date are always used. No executable changes to the existing [supply](#) are recommended until after the date of the latest firm planned [supply](#) for an item. This protects the time frame as the firm planned period.

The following functions provide for firm planned supplies:

Maintenance

Work order maintenance - Set an order as firm planned

[Item schedule](#) maintenance - Set a firm [item schedule](#) as firm planned

MRP

Firm planned supplies due on a date will be netted against [demand](#) after all other supplies due on that date. This minimises suggested changes to firm planned [supply](#) quantities.

Changes are recommended for firm planned supplies to change the [supply](#) quantity (up or down) or [supply](#) date, but note that this is deemed non-executable and is only an indication to the [planner](#) that the change would be desirable if it were possible.

[Dependent demand](#) is always based on the firm [supply](#) quantity.

The [supply production lead time](#) calculation is based on the firm [supply](#) quantity.

The [available stock](#) calculation is based on the firm [supply](#) quantity.

No new supplies are suggested on a date where a firm planned [supply](#) is due, or on any earlier date. It is assumed that the [planner](#) will decide how to address any discrepancy between [supply](#) and [demand](#).

When making enquiries or producing reports after an [MPS](#) run, non-executable actions are indicated by specific action codes.

Frozen Stock Availability

When assessing the availability of stock balances for Lot Header Controlled Items, MPS will consider the setting of the Production Parameter MFSA. If the value of the parameter is set to **0**, stock that is frozen because of its status is extracted as Held Stock, counted as unavailable, and with a recommendation that it should be released immediately, regardless of its Lot Header dates. If the value of the parameter is **1**, stock that is frozen because of its status is treated in a similar manner to stock that does not have a frozen status. Its availability in planning is determined by its batch dates. It is extracted as Released Stock either on the start date of the run, if it has passed its first available date, or on the first available date if it has not yet reached it, with a recommendation to release the stock.

The equivalent function for Items that are not controlled using Lot Headers, both non-Lot and Lot controlled Items, is managed using the PLFS Production Parameter. The MPS detail record has a separate control for lot controlled and non-lot controlled items. If these are switched on, then frozen stock for the items controlled is treated as opening available stock for the purposes of replenishment planning.

MPS Automatic Run Parameters [10/MPS]

[MPS](#) runs may be submitted automatically, as part of the overnight processing, with parameters automatically set for each run.

This task enables those parameters to be defined for [MPS](#) runs by model code. All the currently [available](#) parameters are [available](#) to be set and re-set. Non-working days are taken into account when calculating the current date for the run and the other control dates if necessary.

MPS Automatic Run Parameters Selection Window

To display this window, select the [MPS](#) Automatic Run Parameters task.

You use this window to select the model for which you want to maintain the [MPS](#) automatic run parameters.

Fields

Model

Enter the model for which you want to set [MPS](#) Automatic Run Parameters.

Alternatively, use the prompt facility to select from the Select Model pop-up.

Only the model specified in the [company profile](#) can be used to confirm orders and [schedules](#), as this is the live model. You must enter the live [MPS](#) model here if you need to confirm your suggested [MPS](#) orders and [schedules](#). If you are using the suggestions for planning only, you can enter any model here. The software displays the default calendar code from the model's [reporting profile](#).

Press Enter to display the [MPS](#) Automatic Run Parameters window.

MPS Automatic Run Parameters Window

To display this window, enter a model code and then press Enter on the [MPS](#) Automatic Run Parameters Selection window.

You enter the first set of selection parameters for the run on this window. The dates and other details displayed at the top of the window refer to the last [MPS](#) run for the selected model.

The parameters shown below are re-set to the values indicated on this window when the [MPS](#) run is submitted. The other model parameters are picked up from the Model definition, as for a manually submitted [MPS](#) run. If any change is required to other parameters, they should be maintained through the Maintain Model Stockroom task, using the Additional Parameters function.

The [Scheduled Run Time](#) field should be set to the time at which the day-end job is to be [scheduled](#) for. If the job does run at this time, or shortly after it, as will usually be the case, no date adjustment is made. If, however, the actual submission time of the job is earlier than the expected [scheduled run time](#), it is likely that the submission has been delayed to after midnight, when it would normally run before that. In this case, because the system date is a day later than would normally be the case, the submission dates are adjusted to be one day earlier than they would otherwise have been. The Current Date Number of Days will be reduced by one before calculating the Control Dates. A value of 00:00 is allowed to enable you to ensure that this rule is never invoked.

Fields

Current Date - System Date (+/-)

Use this to adjust the current date of the run to be before or after the system date.

Current Date - System Date Days

Use this to set the number of days by which the current date of the run is to be adjusted.

End Date - Current Date Days

Use this to set the number of days after the current date, set above, on which the end date of the run will be set.

Functions

Show New Run Dates (F16)

Use this to show the dates that will be used if [MPS](#) is run on the current System Date. The literal “Details shown are from the last run” is removed when the window is re-displayed.

Select Save (F8) to save the parameters in the [MPS](#) Automatic Run Parameters file, flagged as [MPS](#), and saved under the model selected.

Machine Manager - Day-end Parameters

For the automatic [MPS](#) run submission to take place, the task must be added to the Day End Parameters. This is maintained through the Machine Manager application on the Manage Auto Day-end Jobs window.

Select **Add (F8)** to add a new job. A window similar to that shown will be displayed, where you can enter the details to control the MPS automatic run submission.

Enter a suitable description for the job and the job queue and job description.

Select **Application Mgr Jobs (F20)** and enter the System21 job details as appropriate, selecting your own environments and companies.

This will cause a job to be submitted for each model in the [MPS](#) Automatic Run Submission Parameters file.

The submitted job name will incorporate the model code of the model being run, to aid identification of the reports that relate to the various model runs.

Enter 1s in the Day Mask field to control which days of the week the job will run.

Enter a time in the [Scheduled](#) Time field if the job is not to run as part of the day-end procedures.

Batch Processing

The automatic day-end job replaces the existing interactive [MPS](#) Automatic Run Parameters task with a new program that accesses the [MPS](#) Automatic Run Submission Parameters file and calculates the run dates for the planning run according to the details on that file. A job is submitted to

execute an [MPS](#) run for each company and model for which a record exists, depending on the weekly template.

The other model details are taken from the Model file as in the current task.

When each [MRP](#) run job is submitted, the processing calculates the dates for the run using the rules defined by the user.

The current date is set to the system date plus or minus the number of days offset. This is subject to adjustment by going back one day if the time of submission is less than the [scheduled run time](#) as defined by the user.

The [start date](#) is set to the current date minus the number of overdue days.

The [time fence](#) date is set to the current date plus the number of [time fence](#) days. This is adjusted if it lands on a non-working day, and is set to the nearest following working day.

The end date is set to the current date plus the number of end date offset days.

Run MPS [11/MPS]

When you run [MPS](#), the software takes the selected planning definition and extracts all the stockrooms defined to the selected model. These stockrooms determine the scope of the [MPS](#) run. The only items extracted for planning are those attached to the stockrooms on the model. The [reporting profile](#) determines how detailed information is placed into time [buckets](#) on reports and enquiries.

The [MPS](#) extract consider [DRP](#) transfer orders as both [demand](#) and [supply](#). Where they are considered as [supply](#), they consider any reserved quantity as unavailable.

Note: *You must make sure that you have maintained calendars to cover the duration of the review including any future years.*

This task, when recommending changes to existing supplies, check for any [planning filters](#) that apply to them. If none are set, the settings for a “blank” filter code are checked for the [supply](#) type. The settings dictate whether recommended changes are allowed or prohibited, e.g. an increase or decrease in quantity on a confirmed order.

It checks for company-specific [planning filters](#) if the [MPS Planning Filter](#) Code Parameter Type is defined as Company Dependent on the Parameters file. Otherwise, it checks for non-company specific filter.

The MPS run takes into account the firm planned status of extracted Purchase Order supplies to modify the planning suggestions that are made. The Firm Planned Time Fence is set to the date of the day following the latest of any firm planned Production supplies or Purchase Order supplies.

In general required planning changes to Firm Planned Purchase Order supplies are transmuted to the equivalent non-executable changes. MPS planning proceeds up to the Time Fence assuming that those changes are not implemented.

Outside MPS, if changes are made to supplies currently lying prior to the Firm Planned Time Fence, warnings are presented that the change is inside the Time Fence.

Master Production Scheduling takes account of the Planning Filter codes defined for Purchase Orders and Purchase Order Lines to manage the planning suggestions that may be generated.

The Planning run will recommend or suppress required date or quantity changes or cancellations as dictated by the Planning Filters and any tolerances or limitations that are defined for them.

Suggested new Purchase Orders are assigned the Planning Filter defined for the Item on the Production Item Master. These values can be amended prior to the creation of the Purchase Order (see below).

Master Production Schedule Run Selection Window

To display this window, select the Run [MPS](#) task.

You use this window to enter the model for which you want to run [MPS](#).

Fields

Model

Enter the model for which you want to run [MPS](#).

Alternatively, use the prompt facility to select from the Select Model pop-up.

Only the model specified in the [company profile](#) can be used to confirm orders and [schedules](#), as this is the live model. You must enter the live [MPS](#) model here if you need to confirm your suggested [MPS](#) orders and [schedules](#). If you are using the suggestions for planning only, you can enter any model here. The software displays the default calendar code from the model's [reporting profile](#).

Press Enter to display the [MPS](#) Run Options window.

MPS Run Options Window

To display this window, enter a model code and then press Enter on the [Master Production Schedule](#) Run Selection window.

You enter the first set of selection parameters for the run on this window. The dates and other details displayed at the top of the window refer to the last [MPS](#) run for the selected model.

Fields

Lowest Level to Review

With [MPS](#), you can [schedule](#) at any level in your product structure, for example, you can control [schedules](#) for end products together with [schedules](#) for [components](#), where one is dependent upon the other.

Enter a level here. This determines the number of levels of product structure that you want to include in the planning process. [MPS items](#) with low-level codes lower than or equal to the level you enter may be considered for review, depending upon their stockroom definition.

If you only want to [schedule](#) the parent items, that is, the end products, leave this field blank or enter **0**. To [schedule](#) first-level items enter **1**, for second-level enter **2**, and so on.

Current Date

Enter or select the date that will be the base date for the run. This is normally the run date, and defaults to the current system date.

The review [start date](#) and frozen [schedule time fence](#) are calculated from this date.

Overdue Days

Enter the number of days of overdue [supply](#) and [demand](#) that you want [MPS](#) to consider. This number of days is subtracted from the current date to give the [MPS start date](#). All supplies and [demand](#) due on or after this date are included.

Time Fence Days

Enter the number of days to be included in the frozen portion of the [schedule](#). The software will not make any recommendations to [schedules](#) due within the [time fence](#) or suggest new orders within it. There are no recommendations made for overdue orders within the [time fence](#) either. The [time fence](#) is calculated as the current date plus the number of days you enter here. The [time fence](#) period is often the lead-time of the [MPS item](#). This is overridden at item level if the Use Item [Time Fence](#) parameter is **checked**.

Safety Horizon Days

Enter the number of safety horizon days here. This entry is used with the item end date to establish [planning horizons](#) for all items in the review. It makes sure that all [generated demand](#) derived from an [MPS](#) plan is included in lower-level analysis. This is overridden at item level if the Use Item End Date parameter is **checked**.

End Date

Enter or select the end date of the [MPS](#) planning run. This date should be at least the longest cumulative lead-time of your end products plus a safety factor.

Terminate on Planning Exception

If item [lead times](#) are used and a [production lead time](#) is defined for an Item that is to be planned, the system will re-calculate the [lead time](#) according to the various elements in the system. If the calculated value is greater than the stored value, the Item will be included on the [MPS Item](#) Exception report.

You can choose whether the planning run should continue when such exceptions have been identified, in which case the calculated values will be used rather than the stored values, or to terminate the run, in which case just the report will be produced.

Unchecked - Not to terminate the run

The Exception report will still be produced, for use with the new planning results.

Checked - To terminate the run

In this case, if the planning run detects a planning exception (as defined above), the run will terminate without committing any changes from the previous plan and a report will be produced listing the exceptions that were found.

The planning run will analyse [lead times](#), by comparing the stored [lead times](#) of Items with the calculated values according to the various elements that comprise the [lead time](#). If this calculation yields a result that is greater than the stored [lead time](#), this will generate an exception, which will be printed on the [MRP](#) Item Exception report.

Specifically, the calculation will take into account [lead time](#) elements that are external to the production process. This includes [release lead times](#) and delivery days.

This calculation will only take place if the item has a [production lead time](#) defined on the Manufacturing Item Master file. Otherwise, the global [lead time](#) is used in all cases. In addition, the item [time fences](#) option needs to be in force for the unit being planned.

This applies to all manufactured and purchased items that are included in a given planning run.

Suppress Low-level Code Generation

Use this checkbox as follows:

Unchecked - Not to suppress low-level code generation

The system displays the warning message *****Changes made in structure currently exist***** if there are any changes to structures, or [non-standard production orders](#) included.

Checked - To suppress low-level code generation

In order to include all requirements for an item, the software must have a record of the lowest level within a planned product structure that the item occurs.

If you have changed product structures during the period since the last [MPS](#) run, the software automatically sets this field to **unchecked** (Generate) so that it can calculate new low-level codes. If the field defaults to **unchecked** (Generate), do not change it to **checked** (Suppress) unless you are sure that the structure changes the software has detected do not affect the model to be processed.

The low-level code routine can be safely suppressed if you generate low-level codes using the Generate [Low Level Codes](#) task from Production utilities before you run [MPS](#).

Functions

Display New Run Dates (F16)

Use this to re-calculate the dates displayed at the top of the window, using the data entered in the fields.

Start Run (F17)

Use this to start the run. This automatically generates a report detailing the [MPS](#) parameters used.

Additional Parameters (F18)

Use this to display the [MPS](#) Additional Parameters window.

Print Details (F22)

Use this to provide a summary report of the selected planning parameters for the [MPS](#) model.

Select **Start Run (F17)** to start the [MPS](#) run.

MPS Additional Parameters Window

To display this window, select **Additional Parameters (F18)** on the [MPS](#) Run Options window.

Use this window to enter selection parameters for the [MPS](#) run.

Fields

Planning Basis

Enter the planning basis for the run. The options are defined in the system parameters under type PBAS.

Enter one of the following:

0 (default) - Standard

This selection operates without multi-plant. The [MPS](#) run is processed at organisational level where all [load](#), [resources](#) and [capacity](#) are considered.

1 - Multi-plant Network

You must first activate multi-plant in the [company profile](#). Multiple planning units can be considered either as a related set of production centres supporting an overall production plan or as autonomous units responsible for their own [supply](#) and [demand](#) situations without reference to other planning units or a higher-level plan.

2 - Multi-sourcing (single planning unit sourcing)

You must first activate multi-sourcing in the [company profile](#). Use this to develop a plan that satisfies [demand](#) by allocating recommended supplies for an item to different manufacturing [routes](#) within a single planning unit. That means multiple [supply](#) options are considered within a single planning unit, and no reference is made to any other planning unit.

Company Model Structure Requirements		A	B	C	D	E	F	G	H
Multi-Plant			Y	Y				Y	Y
Cellular			Y		Y		Y		Y
Multi-Sourcing			Y			Y	Y	Y	
Planning Basis									
Model Type	Execution Level	0	1	2	3				
0	0	A, B, C, D, E, F, G, H							
1	0	B, C, D, E, F, G, H	B, C, G, H	B, E, F, G	B, D, F, H				
2	0	B, C, G, H		B, G	B, H				
3	0	B, D, F, H		B, F					
0	1	A, D*, E, F*							
1	1		B, C, G, H		D, F				
2	1	B, C, G, H		B, E, F, G	B, D, F, H				
3	1	B, D, F, H		B, F					
0	2								
1	2								
2	2								
3	2								
Key:									
Model Type: Blank or 0 = Standard 1 = Central Model 2 = Plant Model 3 = Cell Model					Execution Level: Blank or 0 = Non-Live or Simulation 1 = Autonomous Plan and Execution (Live) 2 = Centralised Plan and Execution				
*Assumes an MPS run									

When you choose the planning basis, first select the company model structure combination you want to use. You can have standard, or any combination of multi-plant, [cellular](#) or multi-sourcing. You set these up in the [company profile](#). Structure H in the diagram represents multi-plant with just [cellular](#) processing. Alternatively, structure B in the diagram represents multi-plant with [cellular](#) and multi-sourcing.

You can then compare the company model structure combination you have selected with your model type and execution level choice. Refer to the Maintain Model Stockroom task for further details of the Model Type and Execution Level fields. For example, where you have Model Type 3 and Execution Level 1, for a company model structure of B, you can choose a planning basis of 2.

Note: You achieve Execution Level 1 for a standard model by quoting the standard model in the Manufacturing [company profile](#).

Note: You can plan [MPS items](#) via the [MRP](#) run if you have generated [triggers](#). You generate [triggers](#) for [MPS items](#) by running the:

Note: Available to Ship Report

Note: Maintain [Supply](#) via [MPS](#) Review

Note: Maintain Line [Schedules](#)

Note: Therefore, you can plan [MPS items](#) using [Cellular Planning](#).

Use Item Time Fence

As an alternative to a global [time fence](#), use this field to specify whether you want to use a [time fence](#) based on each item's production lead-time.

Use this checkbox as follows

Unchecked - To use the [time fence](#) entered for the run

Checked - To use the item [time fence](#)

If no lead-time exists for the item, the [run time fence](#) is used.

Each item's [time fence](#) is calculated by adding its [lead time](#) to the current date of the run.

Use Item End Date

As an alternative to a global end date for the review of each item, you can use an end date based on each item's [cumulative lead time](#).

Use this checkbox as follows:

Checked - If you want to use individual end dates for items

Each item's end date is calculated by adding its [cumulative lead time](#) to the end date defined for the run.

Dependent Requirements Basis

Use this field to define what is passed down from parent to dependent items, that is, the generation of [dependent demand](#) requirements.

Select one of the following:

Suggested (0) - To generate [dependent demand](#) for all production supplies using each [supply's](#) suggested quantity and its suggested due date into Inventory

This reflects changes in dependent terms.

Firm (1) - To generate [dependent demand](#) for firm production supplies using each [supply's](#) firm quantity and firm due date into Inventory

Excluded [dependent demand](#), not referenced by netting, but visible to the [planner](#), is generated for brand new manufacturing [supply](#) suggestions, using each [supply's](#) suggested quantity and suggested due date into Inventory.

Note: An initial [MPS](#) run, with this field set to Suggested, will identify manufacturing suggestions. You can then review these recommendations and make any manual adjustments, if required. You can then re-run [MPS](#) with this field set to Firm to create suggestions for the firm production plan.

Forecast Basis

This field is used to control the dates on which forecasts are deemed to fall. Every individual forecast is extracted on a single date, although the quantity may be intended to cover the forecast requirements for a range of dates.

Select one of the following:

Daily (0) - If the [start date](#) of the forecast is to be used as the forecast date

This means, for example, that a weekly forecast will have the full week [demand](#) appearing on the first day of the week. [MPS](#) will plan to have the full quantity [available](#) on this day.

Period (1) - If the end date of the forecast is to be used as the forecast date

This means that [MPS](#) will not satisfy the full forecast until the last date of the range of dates that it covers. The production of this quantity may be backwards [scheduled](#) through the preceding dates of the period.

Confirmed Schedule Policy

Enter one of the following:

0 - To re-calculate the whole [MPS](#) plan, deleting existing confirmed [schedules](#)

1 - To include any confirmed manufacturing [schedules](#) in the plan

You can use the prompt facility on this field to select from the CNFS Confirmed [Item Schedule](#) Policy pop-up.

Note: This defaults to the value in the Confirmed [Schedule](#) Policy field on the Planning Options window in the [company profile](#), but you can change it.

Include Customer Schedule Arrears

Use this field to specify how overdue [demand](#) from Advanced Customer [Scheduling](#) is considered in the [MPS](#) run.

Use this checkbox as follows:

Unchecked (default) - For [demand](#) from Advanced [Customer Schedules](#) to be included in the quoted model's planning run, if the [schedule's demand](#) date is equal to or later than or the quoted model's current date and earlier than or equal to the planned item's end date

Checked - For [demand](#) from Advanced [Customer Schedules](#) to be included in the quoted model's planning run, if the [schedule's demand](#) date is later than or equal to the quoted model's [start date](#) and earlier than or equal to the planned item's end date

Functions

Inter-model Extract (F15)

Use this to display the Inter-model Extract window, which you use to import suggested [dependent demand](#) from multiple [planning models](#) into the quoted run model.

Select **Update (F8)** to validate the data or press Enter to display the [MPS](#) Additional Parameters Model Details window.

MPS Additional Parameters Model Details Window

To display this window, press Enter on the [MPS](#) Additional Parameters window.

Use this window to enter more selection parameters for the [MPS](#) run.

Fields

Review Demand

Use this field to specify whether you want to review the calculated [demand](#) during an [MPS](#) run.

Use this checkbox as follows:

Unchecked - Not to review [demand](#) during the [MPS](#) run

Checked - To review [demand](#) during the [MPS](#) run

In this case, following the review, you need to resume the run using the Resume [MPS](#) task.

MRP Parent Item Extract

During the [MPS](#) run, [MRP](#) items are analysed to determine whether any have [MPS inputs](#). [MRP](#) items with [MPS](#) dependants are incorporated in the plan so that all relevant [demand](#) is [available](#) to the [MPS](#) dependants. However, this can be a time-consuming process, so this flag is [available](#) for environments where there are no [MPS](#) dependants of [MRP](#) parents. This can reduce the amount of time taken to determine the items to be planned during the [MPS](#) run.

Select one of the following:

Include (0) - To include the extracts for any [MRP](#) parent items with [MPS inputs](#)

Ignore (1) - To ignore the extracts for any [MRP](#) parent items with [MPS inputs](#)

Item Supply Route Policy

Analysis during the [MPS](#) run determines whether new [MPS item](#) suggestions will be raised as part of a process group. This can be a time-consuming process, so you can use this flag for environments where process groups are not used. This can reduce the amount of time taken to determine the items to be planned during the [MPS](#) run.

Select one of the following:

Process Group [Route](#) (0) - If process group [planning routes](#) are used

The process group function will be included in the [MPS](#) run.

Own [Planning Route](#) (1) - If each item has its own [planning route](#)

The process group function will be excluded from the [MPS](#) run.

Daily Summaries for Co-products

You can use this field if process groups are included in the [MPS](#) run. If you are using concurrent co-product planning, every day the system produces a [supply](#) and [demand](#) summary for each co-product in the process group.

Use this checkbox as follows:

Unchecked (default) - Not to save the daily summaries for [co-products](#) for the [MPS](#) review

Checked - To retain daily summaries for [co-products](#) for the [MPS](#) review

Forecast Netting Basis

Use this field to determine the way in which multi-plant forecasts are processed in an [MPS](#) run.

Note: The value you select in this field is only used when the when the Forecast Netting Basis field in the item's production details is left blank.

Select one of the following:

Central (0) - If you want the forecast for the central model to be included in calculations

These forecasts will be netted against the existing [supply](#) in all plant models attached to the central model, subject to an item's [demand policy](#).

Planning Unit (1) - To only include forecasts for planning units, that is, plants, [cells](#), or both, planned within a central model

These forecasts will be netted against independent and [dependent demand](#) at planning unit level, subject to an item's [demand policy](#).

Note: This field is only displayed if the Planning Basis is 1 (Multi-plant).

Multi-sourcing Basis

Use this field to tell [MPS](#) which multi-sourcing rule it needs to apply. You can decide whether to use sourcing rules to satisfy [demand](#), or whether to use an item's own planning policies, that is, item override or item master.

Select one of the following:

Ignore (0) - If you want to ignore multi-sourcing rules (that is, you require single sourcing)

Central+Plan.Unit (1) - To consider rules for the central model [set up](#) with subsets of planning units (for example, central and plant models)

P.Unit (2) - To consider only those multi-sourcing rules that are defined for the planning unit

Note: This field can only be used if the Planning Basis is 1 (Multi-plant).

Save Critical Resource Load

Use this field to specify whether to save the end result of all critical [resources](#), that is, [capacity available](#) and [capacity](#) unused, for each [reporting profile](#) period. You could use this to determine why the software suggests producing particular products on particular [routes](#).

Use this checkbox as follows:

Unchecked - Not to save the critical resource [load](#)

Checked - To save the critical resource [load](#)

Note: This field is only applicable if multi-sourcing is defined as a requirement in the [Production company profile](#).

Critical Resource Load Policy

Use this field to define how the critical resource opening [capacity balance](#) will be constructed.

Select one of the following:

Refresh (0)

Each critical resource will be fully [available](#) each time the model is run.

Alternative Model Profile (1)

If you use this, you must enter a model in the Alternative Resource Model field. Each critical resource will be fully [available](#) each time the model is run. The [reporting profile](#) of the quoted alternative model will be used to configure resource [loadings](#).

Alternative Model with Update (2)

If you select this, you must enter a model in the Alternative Resource Model field. The opening resource [balance](#) will be taken from the quoted alternative resource model. On completion of the planning run, any additional resource consumption will be reflected in the resource [balance](#) of the alternative model.

Daily Resource [Loading](#) (3)

This allows critical resource [loads](#) to be viewed in daily [buckets](#) rather than by [reporting profile](#), up to a maximum of one year.

Note: This field is only applicable if multi-sourcing is defined as a requirement in the [Production company profile](#).

Alternative Resource Model

You must enter a model in this field if you selected **Alternative Model Profile** or **Alternative Model with Update** in the Critical Resource [Load](#) Policy field.

Note: This field is only applicable if multi-sourcing is defined as a requirement in the [Production company profile](#).

Select **Update (F8)** to validate all the data and return to the [MPS](#) Run Options window.

Review Demand [12/MPS]

The calculated planned [demand](#) can be examined before it is used to calculate the [MPS](#). The [demand](#) can also be maintained before resuming the run. Any adjustments that you make are flagged as manual adjustments and identified by the user ID in the plan.

You must select the option to stop the run to allow a review of demand at the start of the run. You do this by **checking** the Review Demand field, which is accessed through the additional parameters within the MPS run. If you start a run without **checking** the Review Demand field, the run continues until it is fully complete and you cannot review it.

MPS Demand Review Selection Window

To display this window, select the Review [Demand](#) task.

Use this window to select the model and item for review. You can review the [demand](#) extracted by [MPS](#) on an item-by-item basis.

If you are using multi-plant, you can also enter the plant.

Fields

Model

Enter the model over which [MPS](#) is being run, and which you want to review.

Alternatively, use the prompt facility to select from the Select Model pop-up.

Item

Enter the item for which you wish to maintain the [demand](#). You will see the calculated [demand](#) using the [demand policy](#) code selected for this item in the Item Master file.

You can use the prompt facility on this field to select from the Select Item pop-up.

Plant

Where multiple plants are included in the [MPS](#) run, you can specify a plant here for the [demand](#) review. If you do not select a plant, the model [demand](#) will be shown on the next window.

You can use the prompt facility on this field to select from the Select Model pop-up.

Press Enter to display the [MPS Demand](#) Review [Net Demand](#) window.

MPS Demand Review Net Demand Window

To display this window, press Enter on the [MPS Demand](#) Review Selection window.

This window displays the following information:

- The model and item codes
- The plant, if multi-plant is active and you entered a plant on the MPS Demand Review Selection window
- The demand policy
- The independent demand, if the demand policy for the item is not 5
- The forecast comparison, if the demand policy for the item is 1 or 2
- The period start and end dates
- The forecast quantity
- Any existing sales or distribution orders
- Any existing customer schedules, if you are using Advanced Customer Scheduling

Fields

Net Demand

This field defaults to the [net demand](#) as calculated by [MPS](#). You can amend the [demand](#) quantities before continuing the [MPS](#) run.

Functions

Item Netting Policies (F19)

Use this to display Item Netting Policies pop-up, showing the [Demand](#), [Independent Demand](#) and Forecast Consumption policies as defined for this item in the item's production details. This is for information only and cannot be amended.

Select **Update (F8)** to validate your data and leave the task.

Resume MPS [13/MPS]

After you have reviewed the [demand](#), you use this task to resume the [MPS](#) run so that the final [MPS](#) calculation can be made. However, you can start a further [MPS](#) run without resuming the previous run. If a run has been made without reviewing [demand](#), it is still possible to do this after the run has been fully completed, but it will be necessary to re-run [MPS](#) to make any changes effective.

MPS Run Model Selection Window

To display this window, select the Resume [MPS](#) task.

Note: *The model you enter should be one for which the [demand](#) has been reviewed.*

Use this window to select the model for which [demand](#) was reviewed.

Fields

Model

Enter the model for which [MPS](#) is to be resumed.

Alternatively, use the prompt facility to select from the Select Model pop-up.

Press Enter to display the [MPS](#) Run Options Details window.

MPS Run Options Details Window

To display this window, enter or select the required model and then press Enter on the [MPS](#) Run Model Selection window.

This window displays details of the [MPS](#) run for which [demand](#) was reviewed.

- Select **Continue Run (F17)** to resume the [MPS](#) run, after you have made any required adjustments.

Review MPS [14/MPS]

Use this task to review the results of the last [MPS](#) run.

Model Selection Window

To display this window, select the Review [MPS](#) task.

You use this window to enter the model for which you want to review the results of the [MPS](#) run.

Fields

Model

Enter the model you want to review.

Alternatively, use the prompt facility to select from the Select Model pop-up.

Functions

List by Supply/Demand Variance (F17)

Use this to see how closely the last [MPS](#) run succeeded in matching the overall [demand](#).

Press Enter to display the [MPS](#) Enquiry Item Selection window or select **List by Supply/Demand Variance (F17)**.

Supply/Demand Variance Enquiry Selection Window

To display this window, select **List by Supply/Demand Variance (F17)** on the [MPS](#) Enquiry Selection window.

From the nature of planning, particularly the planning of [co-products](#), it is possible for the supplies of Items to be in excess of or below their [demands](#). For example: a surplus can be generated when an item is produced in conjunction with a co-product that is produced in a quantity to satisfy its own [demand](#), where the equivalent [demand](#) does not exist for the first item. A deficit can occur when an item is only made in conjunction with other products, according to the [demand](#) for those other products, but the total [demand](#) for those other products is not sufficient to generate a high enough quantity of the first item.

This enquiry uses data created during the [MPS](#) run, to calculate the overall [supply](#) and [demand](#) total for the Items in a selected range. These items are then listed down the window with the largest percentage discrepancy between [supply](#) and [demand](#) at the top, descending to the lowest, and can be selected to display the [MPS](#) Review pop-up. This displays the detailed results of the [supply](#) strategies employed, which can be adjusted to attempt to improve the [supply](#) position.

Use this window to enter the required parameters for the enquiry.

Fields

Control Date

This must be a valid date between the start and end dates of the last [MPS](#) run. The default value is the end date of the last [MPS](#) run. It determines which supplies and [demands](#) are to be included in the calculations.

GT Family

You can optionally enter a valid [GT Family](#). If used, this field restricts the enquiry items to those that have this [GT family](#) code defined.

Item Range From/To

Enter a valid item range or leave this field blank to display all items.

You can use the prompt facility on these fields to select from the Select Item pop-up.

Cut Off

This field is used to limit the amount of information displayed on subsequent window where items are listed with the largest percentage discrepancy at the top. The cut-off percentage is used to [supply](#) a cut-off point, below which items will not be presented. It can be any number up to 999%. This is because the [variance](#) can be many times the [demand](#).

Press Enter to display the [Supply/Demand Variance](#) Enquiry window.

Supply/Demand Variance Enquiry Window

To display this window, press Enter on the [Supply/Demand Variance](#) Enquiry Selection window.

Items that fall within the selection criteria specified on the previous window are displayed, with the largest percentage [variance](#) between [supply](#) and [demand](#) at the top of the list.

This enquiry provides a method of drawing the master [scheduler's](#) attention to those items that will potentially be the most problematical. It can be particularly useful in a co-product manufacturing environment, where production of an item may be dictated by the requirement for another item with which it is a co-product. This can lead to over-[supply](#) or under-[supply](#) of the items that are not used to drive the [supply](#). It may be possible to vary the product mix or production methods to produce different combinations of [co-products](#). This enquiry can show the predicted results of different stratagems.

Items that have been reviewed are highlighted on return to the summary list, to indicate that there may be pending changes that will be applied when the display is refreshed.

The [variance](#) is given first as an absolute number, expressed in the stock keeping units of the item. The sign of the quantity indicates whether the [variance](#) is in an under-[supply](#) or over-[supply](#) condition, but it is the size of the [variance](#) which controls the sequence in the list. The [variance](#) quantity is valued using the standard [cost](#) of the item, to give an idea of the significance of the discrepancy in financial terms. The [variance](#) is also represented as a percentage of the [demand](#). The items are listed by the size of the [variance](#) percentage.

Options

Select

Use this to select an item for review on the [MPS](#) Review pop-up.

Functions**Refresh (F5)**

Use this to refresh the window after changes have been made.

Select an item for review or select **Previous (F12)** to return to the previous window.

MPS Enquiry Item Selection Window

To display this window, press Enter on the [MPS](#) Enquiry Selection window.

You use this window to enter more selection criteria for the enquiry. You can enter the item, plant or [planner](#) codes.

Fields**Model**

This field is displayed for your information only and cannot be amended.

Select Item

Enter an item to review. If the item does not exist, the details for the next [MPS item](#) will be displayed.

You can use the prompt facility on this field to select from the Select Item pop-up.

Plant

This field is only displayed if you set the Planning Basis field on the [MPS](#) Additional Parameters window within the Run [MPS](#) task to **1** (Multi-plant).

Leave this field blank to produce a global view of all plants and the central model where the item exists.

Enter a specific plant to limit the enquiry to one plant. You can enter the central model.

You can use the prompt facility on this field to select from the Select Model pop-up.

Planner

Enter a [planner](#) if you want the review only to include items for that [planner](#). If the [planner](#) does not exist, the details of the next [planner](#) will be displayed.

You can use the prompt facility on this field to select from the PLAN [Planner](#) Code pop-up.

Default Detail Panel

Use this checkbox as follows:

Unchecked - If the [MPS](#) Enquiry Summary window is to be the default

Checked - If the [MPS](#) Enquiry Detail window is to be the default

The window you have selected will remain the default while you stay in the task.

Press Enter to display either the [MPS](#) Enquiry Summary window or the [MPS](#) Enquiry Detail window, depending on the Default Detail Panel field.

MPS Enquiry Summary Window

To display this, leave the Default Detail Panel field unchecked and then press Enter on the [MPS](#) Enquiry Item Selection window.

This window displays a summary of the item [supply](#) and [demand schedule](#), using the item periods defined in the model. The exact information displayed on this window depends on your selection criteria.

The top part of the window displays information about the [MPS](#) run and the item.

The bottom part of the window displays a list of [time fence](#) periods, starting with any overdue [demand](#) and a total for all of the displayed periods.

The following information is displayed for each period:

- Actual Demand
 - Total Sales Demand + Dependent Demand due in the period
 - Dependent demand is the generated component requirements for orders, offset by lead-time from the parent order due date.
- Forecast
 - The total of sales forecasts and stock forecasts in the period
- Adjusted Demand
 - The calculated demand due in the summary reporting period
 - This quantity is a function of comparing the actual demand with the sales forecast as determined by the demand policy for the item, along with the forecast consumption method and manual adjustments to demand.
- Supply
 - This is the total of existing supplies in the reporting period, before any intervention that may have been recommended by the planning run.
- Available
 - This is calculated as Previous Period Quantity Available + Supply - Adjusted Demand. In the first period, Previous Period Quantity Available = Physical Stock on hand.
- Net Requirement
 - This is calculated as Adjusted Demand + Safety Stock + Safety Cover + Largest Stock Forecast in period - Previous Period Available - Existing Supplies.
- Planned Receipts

This is the MRP suggested supply schedule for production orders, production schedules, transfer orders, stock becoming available, and purchase orders. This shows the total of all MRP recommended supplies due in the period.

- **Planned Available**

This is calculated as Previous Period Planned Available + Planned Receipts - Adjusted Demand. In the first period, Previous Planned Available = Physical Stock on hand.

Note: You can use *Page Up* and *Page Down* to display the previous or next periods.

Fields

Item

Enter a valid item to display planning summary for that item.

Alternatively, use the prompt facility to select from the Select Item pop-up.

This is equivalent to returning to the previous window and changing the item.

Functions

Previous Item (F16)

Use this to display details of the item before the one currently displayed.

Detail (F17)

Use this to display the [MPS](#) Enquiry Detail window.

Next Item (F19)

Use this to display details of the item following the one currently displayed, or the next item within this [planner](#) group.

Next Planner (F20)

Use this to display the first item from the next [planner](#) group.

Select **Detail (F17)** to display the [MPS](#) Enquiry Detail window for the item.

Alternatively, select **Exit (F3)** to leave the task.

MPS Enquiry Detail Window

To display this window, checked the Default Detail Panel field and then press Enter on the [MPS](#) Enquiry Item Selection window.

Alternatively, select **Detail (F17)** on the [MPS](#) Enquiry Summary window.

This window displays the detailed results of the [MPS](#) run for this item. All [supply](#) or [demand](#) records processed or generated by the [MPS](#) run are displayed, together with their corresponding recommendations and projected inventory [balances](#).

The following details are displayed:

- The planning model
- The start date
- The time fence
- This is suppressed if a global view is taken for a multi-plant review because it could differ for each item/model.
- The F/C (forecast) time fence
- This is suppressed if a global view is taken for a multi-plant review because it could differ for each item/model.
- The end date

This is suppressed if a global view is taken for a multi-plant review because it could differ for each item/model.

- The item code and description
- The plant
- This is shown if a plant-specific view is taken
- The planning basis
- The MPS date

For generated demand, this is the required date of the demand, reflecting higher-level MPS suggestions. For independent demand, the forecast or shipment date is displayed. For a supply, it is either the MPS recommended due date or the current due date, depending on the display. If the date is shown as 99*** this indicates a zero demand, with an existing supply.

If the parameter PLRV is set to 1, this shows the MPS delivery date.

- The demand quantity
- The supply reference

This could be the production route that will be used to supply the item, or the purchase order number (if the item is a purchased one), or the stockroom where the supply material is normally held. For example, SR:RM indicates stockroom RM. It could also be the work order number or transfer order.

- The supply quantity
- The available stock

This is the net quantity, taking into account all supplies and demands up to the line.

Status Codes

The following [Demand](#) Status and [Supply](#) Status codes can be displayed:

Demand Status Codes

- C1 - Customer schedule horizon 1
- C2 - Customer schedule horizon 2
- C3 - Customer schedule horizon 3
- C4 - Customer schedule horizon 4
- C5 - Customer schedule horizon 5

-
- CA - Cancelled
 - CC - Concurrent co-product demand
 - CD - Cumulative demand
 - CI - Customer schedule Daily Call In (DCI)
 - CR - Customer schedule Receipt Advice Notification (RAN)
 - CS - Confirmed schedule (for parent)
 - CW - Confirmed production order (for parent)
 - DO - Firm distribution order
 - DX - Excluded firm distribution order
 - FC - Sales forecast
 - FI - Forecast excluded by forecast time fence
 - FS - Stock forecast
 - FX - Excluded sales forecast
 - IW - Active production order
 - MA - Manual adjustment
 - OS - Out of date stock
 - PW - Planned production order (for parent)
 - PX - Excluded suggested purchase order
 - RW - Released production order (for parent)
 - SC - Safety cover
 - SO - Sales order
 - SP - Suggested purchase order
 - SS - Suggested schedule
 - ST - Suggested transfer order
 - SW - Suggested production order
 - SX - Excluded sales order
 - TO - Firm transfer order
 - TX - Excluded firm transfer order
 - WX - Excluded production order
 - XC - Excluded safety cover
 - X1 - Excluded customer schedule horizon 1
 - X2 - Excluded customer schedule horizon 2
 - X3 - Excluded customer schedule horizon 3
 - X4 - Excluded customer schedule horizon 4
 - X5 - Excluded customer schedule horizon 5
 - XI - Excluded customer schedule Daily Call In (DCI)
 - XR - Excluded customer schedule Receipt Advice Notification (RAN)
 - XS - Excluded firm schedule

- XT - Excluded suggested transfer order
- XW - Excluded phantom suggested production order

Note: *Suspended sales orders with suspend codes included in Manufacturing parameter OEIG will not be included in the run.*

For further codes, refer to parameter type PDSC within the Maintain Parameters section in the Production System Utilities chapter of the Production Definition Management product guide.

Supply Status Codes

- CN - Cancelled
- CP - Confirmed purchase order
- CS - Confirmed schedule
- CW - Confirmed production order
- DO - Firm distribution order
- EX - Expired stock
- GI - Goods inwards (Purchase Management)
- HD - Held stock
- IS - Inspection (Purchase Management)
- IW - Active production order
- PA - Past available date stock
- PW - Planned production order
- RS - Released stock
- RW - Released production order
- SP - Suggested purchase order
- SS - Suggested schedule
- ST - Suggested transfer order
- SW - Suggested production order
- TI - In transit stock
- TO - Firm transfer order
- UP - No call off (balance of blanket purchase order)
- XW - Phantom suggested production order

For further codes, refer to parameter type PSSC within the Maintain Parameters section in the Production System Utilities chapter of the Production Definition Management product guide.

Action

This is the recommended action for the [supply](#) order. One of the major purposes of [MPS](#) is to provide planning support for order actions needed for the orderly [supply](#) of material.

[MPS](#) provides information to assist [planners](#) in making decisions on the required action to optimise the [supply schedule](#). Procurement of purchased items is also supported by suggestions to change purchasing [schedules](#) and to create new purchase orders.

The advice is based on the latest status of material requirements and the current inventory [order status](#). The software can make the following recommendations:

- CA - Cancel supply
- CQ - Change quantity
- CS - Create supply
- DI - Dispose of lot
- EC - Non-executable change of quantity with potential effectivity check for components
- EF - Check effectivity
- EI - Expedite and check effectivity
- EICQ - Expedite, change quantity and check effectivity
- EL - Extend life of lot
- EO - Defer and check effectivity
- EOCQ - Defer, change quantity and check effectivity
- EQCQ - Change quantity and check effectivity
- MS - Manual supply
- NI - Non-executable expedite
- NINQ - Non-executable expedite and change quantity
- NO - Non-executable defer
- NONQ - Non-executable re-schedule out and change quantity
- NQ - Non-executable change quantity
- PS - Supply raised post item plan
- RI - Re-schedule in (expedite)
- RICQ - Expedite and change quantity
- RL - Release lot
- RO - Re-schedule out (defer)
- ROCG - Defer and change quantity

For further codes, refer to parameter type PEXC within the Maintain Parameters section in the Production System Utilities chapter of the Production Definition Management product guide.

Available

This is the [planned available stock](#). The [MPS](#) recommended due date sequence reflects the [supply](#) recommendations. In current due date sequence, it reflects the current [supply schedule](#) in terms of quantities and due dates. It is calculated for each day that a [demand](#) or [supply](#) line is present and represents the projected inventory level.

In [MPS](#) recommendation sequence, this field is calculated as [physical stock](#) (first detail line only) or quantity [available](#) on previous date minus [demand](#) for that date plus supplies currently due on that date.

Fields

Item

Enter a valid item to display planning detail for that item.

Alternatively, use the prompt facility to select from the Select Item pop-up.

This is equivalent to returning to the previous window and changing the item.

Options**Maintain Supply**

Use this to display the [Supply](#) Maintenance pop-up, where you can maintain the existing [schedule](#) item [supply](#).

If the [supply](#) is a process group and comprises multiple [outputs](#), when the process group is changed, all the [supply](#) records for the original group are removed and replaced with a set of [outputs](#) defined on the new process group/[route](#). The quantity displayed (whether amended or not) is used to set the quantity of the [primary co-product](#) on the process group/[route](#). This quantity can then be used to calculate the equivalent quantities of other [outputs](#) on the [route](#). There is no need to re-run [MPS](#) to see the effect of these changes.

Note: *The new process group must have the same [primary co-product](#) as the original process group. If you want to replace the [supply](#) with a process group that is more loosely related, it will be necessary to delete the [supply](#) and create a brand new [supply](#) for the process group with another [primary co-product](#).*

For Suggested Purchase Order supplies, the Planning Filter is maintained using Maintain Supply against the line. The MPS/MRP Filter entered here is passed through to the Requisition and from there on to the Purchase Order itself when it is created.

Display All Outputs

Use this to display the [MPS All Outputs](#) pop-up, which shows all [outputs](#) for a process group item only.

Note: *If you select a [supply](#) item which, at the end of the production process, creates additional [outputs](#) (for example [by-products](#) or waste), when you select Display All [Outputs](#), the [MPS All Outputs](#) pop-up displays the [outputs](#) for the process group of the [primary co-product](#).*

Dependent Requirements

Use this to display the [MPS](#) Dependent Requirements window. This window displays all [input](#) requirements for the selected [supply](#).

Maintain Order

Use this to select a production order for maintenance. This displays the Production Order Maintenance window. You use this window to maintain an existing production order or create a new order against a suggested order. If you are using multi-plant or multi-sourcing, the plant is displayed.

Note: *You can also use the Confirm MPS Suggested Orders task to create production orders in bulk. You can confirm (that is, make firm) suggested schedules using the Confirm MPS Suggested Schedules task.*

For existing Purchase Orders, maintenance of the MPS/MRP Filter and the Firm Planned Order Status flag can be effected using the Maintain Order option. This is only available if the MPOP Parameter is switched on, which allows access to Purchase Order Maintenance from MPS/MRP. Otherwise the Filters and Firm Planned Flag must be maintained through the Purchase Management options.

Caution: You can only maintain and create production orders for the planning model defined in the company profile, or for an autonomous plant.

Peg Demand

This pegs [dependent demand](#) only. This displays the [MPS](#) (or [MRP](#)) [schedule](#) for the parent item that generated the [demand](#). This is only possible for [component](#) items.

Supply Details

Use this if the planning basis is multi-plant or single unit sourcing. If you are enquiring on a sourced plant model within, or independent of, a central model, use this to display the [MPS Supply](#) Details window.

Demand Details

Use this if the planning basis is multi-plant or single unit sourcing. If you are enquiring on a sourced plant model within, or independent of, a central model, use this to display the [MPS Demand](#) Details window.

Review Individual Item Schedule

Use this to display the [MPS](#) Review [Item Schedule](#) window. This window displays details of the [scheduled supply](#).

Note: This is only displayed if you are reviewing a live [MPS](#) model.

Functions

Refresh (F5)

Use this to refresh the display after making changes.

Review Scheduled Demand (F6)

Use this to display the [MPS](#) Review [Scheduled](#) Requirements window. This window displays the [scheduled](#) daily material requirements together with the [input](#) item's [supply](#) plan or firm [work station schedule](#).

Item Schedule Quantity Required/Remaining (F7)

Use this to toggle the display between the [item schedule's](#) original or outstanding quantity.

Review Projected Demand (F9)

Use this to display the [MPS](#) Review [Scheduled](#) Requirements window with projected [demand](#). This window displays the [scheduled](#) daily material requirements together with the [input](#) item's [supply](#) plan or firm [work station schedule](#).

New Supply (F10)

Use this to add a new [supply](#) on the [MPS Supply](#) Maintenance pop-up.

Review Item Schedule - All (F13)

Use this to display the [MPS](#) Review [Item Schedules](#) window with all [scheduled](#) supplies in terms of the [MPS item supply](#) plan and the detailed [work station](#) plan.

Show/Hide Excluded Demand (F14)

Use this to toggle between displaying and hiding excluded [demand](#) ([demand](#) that is excluded from the netting process).

Include/Exclude Zero Supply (F15)

Use this to toggle between displaying results including and excluding zero [supply](#).

Previous Item (F16)

Use this to display the previous item.

Summary (F17)

Use this to display the [MPS](#) Enquiry Summary window for this item.

Review Item Details (F18)

Use this to display the [MPS](#) Header Details pop-up.

Next Item (F19)

Use this to display the next item, or the next item within this [planner](#) group.

Next Planner (F20)

Use this to display the first item from the next [planner](#) group.

Change Sequence (F21)

Use this to toggle between the recommended [MPS](#) dates and quantities and the planned dates and quantities. If the Manufacturing parameter PLRV detail record has been set to **1** (in the right-hand field), the effect of any [release lead time](#) or [delivery lead time](#) set against the item may be seen. In this case, four different windows are displayed using this.

***Note:** The [dependent demand](#) for a given date is always generated from a higher-level recommendation and represents the [MPS](#) suggested or firm [schedule](#). It does not change when the [supply](#) sequence is changed.*

***Note:** Only one detail code is allowed within parameter PLRV.*

Detail Line (F22)

Use this to display additional details for each line. Details shown include the due date, earliest and latest [start dates](#), and the [demand](#) reference.

Select **Previous (F12)** to return to the previous window.

MPS Supply Maintenance Pop-up

To display this pop-up, select Maintain [Supply](#) against a line on the [MPS](#) Enquiry Detail window.

Alternatively, select **New Supply (F10)** on the [MPS](#) Enquiry Detail window.

If you are operating multi-plant or multi-sourcing, the associated plant is displayed.

Use this window to create a new item [supply](#) or maintain an existing item [supply](#). For a new [supply](#) where the item is manufactured, the pop-up defaults to the [planning route](#) specific to that plant in a multi-plant or plant environment where a plant-specific view is taken. Otherwise, the item master [planning route](#) is the default.

Fields

Process Group

Enter a process group if required.

Due Date

This field displays the date suggested by [MPS](#), offset if necessary by the delivery or [release lead time](#). It is the current [creation date](#) for an existing [supply](#). You can set an [MRP trigger](#) by amending the date on a firm [schedule](#).

For suggested supplies for purchased items, if a Supplier Calendar is defined for the Supplier, Supplier/Item, or Supplier/Item/Stockroom, then the Due Date entered is checked to ensure that it is a valid delivery date on the Supplier's Delivery Schedule. If it is not, a warning message is issued, to warn that the Due Date may not be achievable. The date can be accepted as it is, or a new date can be selected from a list of available delivery dates.

Supply Date

If you have defined a [delivery lead time](#) in the item's Production details or a [release lead time](#) in the Inventory Lot Header parameters for this item, this date is the date that is offset from the due date by the number of days you specified for this item. This is the date that the supply quantity is available to be used to satisfy demand for the item.

Quantity

This field displays the quantity suggested by [MPS](#) for a new suggestion. For an existing [supply](#) it is the current quantity. You can set an [MRP trigger](#) by amending the quantity on a firm [schedule](#).

Route

This field displays the production [route](#) for the [supply](#). You can change the [route](#) here.

Alternatively, use the prompt facility to select from the Select [Route](#) pop-up.

Planning Filter

You can enter the [planning filter](#) for the Supply. The Filter can be selected from the prompt window, which shows the available Planning Filters that are defined for the Supply Type.

If you enter a value, this is validated against company-specific filters if the [MPS Planning Filter](#) Code parameter type is defined as company-dependent in the Parameters file. Otherwise, it checks for non-company-specific filters.

Confirm Schedule

This field is displayed for [schedule](#)-controlled items only.

Use this checkbox as follows:

Unchecked - To return a confirmed [schedule](#) to suggested, as long as an equivalent firm [work station schedule](#) does not exist

Checked - To change to a confirmed [schedule](#), which is optionally retained on the next [MPS](#) run

Firm Planned Supply

This field is displayed for [schedule](#)-controlled items and Purchased Items only.

Use this checkbox as follows:

Unchecked - If this is not a firm planned [supply](#)

Checked - If this is a firm planned [supply](#) (that is, planned [supply](#) that is frozen by the [planner](#) in terms of its quantity and timing).

Select **Previous (F12)** to re-display the [MPS](#) Enquiry Detail window.

MPS All Outputs Pop-up

To display this window, select Display Outputs against a line on the [MPS](#) Enquiry Detail window.

This pop-up displays all [outputs](#) for a process group item.

If you enter a co-product item or a concurrent process group item in the Select Item field on the [MPS](#) Enquiry Item Selection window, this pop-up displays all the [outputs](#) for the [supply](#). For new suggestions, they are calculated in the ratios of the quantities on the [planning route](#). Each [output](#) for the process group will also have its own individual [MPS](#) plan.

Functions

Planned Quantities/Suggested Quantities (F19)

Use this to toggle the display between the suggested quantities and the planned quantities. For existing supplies, the planned quantity is the current quantity.

Daily Summaries (F20)

This function is only [available](#) if the Daily Summaries for [Co-products](#) field was **checked** on the [MPS](#) Run Additional Parameters window. It displays a window showing the daily [demand](#) and [supply](#) summary information that was calculated for each co-product during the run.

Select **Previous (F12)** to return to the [MPS](#) Enquiry Detail window.

MPS Daily Co-product Summaries Window

To display this window, select **Daily Summaries (F20)** on the [MPS](#) All [Outputs](#) pop-up.

This window displays all the calculated daily [demands](#) and supplies for the [co-products](#) in the process group selected. The daily summaries are shown for the date of the selected [supply](#) on the [MPS All Outputs](#) window.

This window shows the daily quantities for each co-product. The opening stock is first adjusted by existing supplies and the total [demand](#) to give a [net demand](#) for each item. This [net demand](#) is then converted into its equivalent quantity as expressed in terms of the process group. The co-product with the largest resulting [demand](#) in process group terms becomes the [demand](#) driver for that date. The last field shows the resulting closing [available](#) quantities for each of the [co-products](#).

Functions

Detail (F17)

Use this to display the full [demand](#) details for all the [co-products](#) on the date in question.

Select **Previous (F12)** to return to the [MPS All Outputs](#) pop-up.

MPS Daily Co-product Demand Details

To display this window, select **Detail (F17)** in the [MPS](#) Daily Co-product Summaries window.

This window displays all the daily [demand](#) for the [co-products](#) in the process group selected. The daily [demands](#) are shown for the date of the selected [supply](#) on the [MPS All Outputs](#) pop-up.

Select **Previous (F12)** to return to the [MPS](#) Daily Co-product Summaries window.

MPS Dependent Requirements Window

To display this window, select Dependent Requirements against a line on the [MPS](#) Enquiry Detail window.

This window displays all [input](#) requirements for the selected [supply](#). It provides you with the ability to drill down from the [supply](#) for a manufacturing parent to its dependent [components](#).

The top part of the window displays the following:

- Sets of related demand and supply
 - Each selected demand in conjunction with any other demands considered during the last planning run
 - The supply recommendations for this demand
 - Each selected supply in conjunction with any other supplies considered during the last planning run
 - The demand that drove the supply recommendations

[Supply](#) details show the suggested or planned [supply](#) date and quantity, together with the type from the planning review

The bottom part of the window displays the [dependent demand](#) requirements for the [supply](#) selected on the previous window.

Fields

Top Part of Window

Option (O)

Enter one of the following:

- 2 - To display the [MPS Supply](#) Maintenance pop-up, where you can maintain the existing [schedule](#) item [supply](#)
- 3 - To display the [MPS](#) All [Outputs](#) pop-up, which shows all [outputs](#) for a concurrent co-product process group item only
- 4 - To display the [MPS](#) Dependent Requirements window, which displays all [input](#) requirements for the selected [supply](#)
- 5 - To select a production order for maintenance

This displays the Production Order Maintenance window. You use this window to maintain an existing production order or create a new order against a suggested order. If you are using multi-plant or multi-sourcing, the plant is displayed.

Note: You can also use the Confirm MPS Suggested Orders task to create production orders in bulk. You can confirm suggested schedules, that is, make firm, using the Confirm MPS Suggested Schedules task.

Caution: You can only maintain and create production orders for the planning model defined in the company profile, or for an autonomous plant.

- 6 - To peg [dependent demand](#) only

This displays the [schedule](#) for the parent item that generated the [demand](#). This is only possible for [component](#) items.

- 7 - To display the [MPS Supply](#) Details window if you are enquiring on a sourced plant model within, or independent of, a central model

Use this if the planning basis is multi-plant or single unit sourcing.

- 8 - To display the [MPS Demand](#) Details window if you are enquiring on a sourced plant model within, or independent of, a central model

Use this if the planning basis is multi-plant or single unit sourcing.

- 9 - To display the [MPS](#) Review [Item Schedule](#) window, with details of the [scheduled supply](#)

Bottom Part of Window

Option (O)

Enter one of the following:

- 3 - To display the [MPS](#) Review [Scheduled](#) Requirements window, showing the [scheduled](#) daily material requirements, together with the [input](#) item's [supply](#) plan or firm [work station schedule](#)

4 - To display the [MPS](#) Review [Scheduled](#) Requirements window, with projected [demand](#)

This window displays the [scheduled](#) daily material requirements together with the [input](#) item's [supply](#) plan or firm [work station schedule](#).

6 - To peg [dependent demand](#) only

This displays the [schedule](#) for the parent item that generated the [demand](#) and is only [available](#) for [component](#) items.

8 - To display the [MPS Demand](#) Details window if you are enquiring on a sourced plant model within, or independent of, a central model

Use this if the planning basis is multi-plant or single unit sourcing.

Functions

Show/Hide Exc Demand (F14)

Use this to toggle between displaying hiding excluded [demand](#), that is, [demand](#) that is excluded from the netting process.

Inc/Exc Zero Supply (F15)

Use this to toggle between displaying results including and excluding zero [supply](#).

Key (F19)

Use this to display a pop-up showing a key to the symbols used on this window.

Pegging Outcome (F20)

Use this to determine which window is displayed when you peg [demand](#) by entering **6** against it. When you use this, the text displayed in the top part of the window shows how the pegged [demand](#) will be displayed.

Change Sequence (F21)

Use this to toggle between the recommended dates and quantities, and the planned dates and quantities. If the PLRV parameter is set to **1**, it is also possible to view the details by either [supply](#) dates or the [creation dates](#), taking the [delivery lead times](#) or [release lead times](#) into account.

Expand/Contract (F22)

Use this to show or hide the [dependent demand](#) part of the window. This is useful to give more visibility of traced [component demand](#) and [supply](#).

Select **Previous (F12)** to return to the [MPS](#) Enquiry Detail window.

MPS Supply Details Window

To display this window, select Supply Details against a line on the [MPS](#) Enquiry Detail window.

Note: Use this if the planning basis is multi-plant or single unit sourcing.

This window displays the [demand](#) relating to the selected [supply](#). At plant level, this shows why the [supply](#) was raised.

Options

Demand Parameters

Use this to display the [demand](#) parameters used when processing the [demand](#).

Peg to Demand

Use this to peg to the item [demand](#) plant. This will display the source of the [demand](#) relating to the [supply](#) you have selected.

Functions

Peg to Transfer (F6)

Use this to peg to the item transfer from the plant. This will display the source of the distribution order or transfer order relating to the [supply](#) you have selected.

Note: *This is only applicable if you are reviewing a distribution order, transfer order, or in-transit [supply](#).*

Supply Parameters (F14)

Use this to display the [supply](#) parameters used ([supply](#) policy, and so on) to generate a new [supply](#), or suggest a change to an existing firm [supply](#).

Rule Details (F15)

Use this to display the sourcing rule type used to generate the suggested [supply](#) and the resultant outcome.

Select **Previous (F12)** to return to the [MPS](#) Enquiry Detail window.

MPS Supply Parameters Pop-up

To display this window, select **Supply Parameters (F14)** on the [MPS Supply](#) Details window.

Alternatively, select [Supply](#) Parameters against a line on the [MPS Demand](#) Details window.

You use this window to view filter settings depending on the type of [supply](#) selected.

Select **Previous (F12)** to return to the previous window.

MPS Demand Details Window

To display this window, select [Demand](#) Details against a line on the [MPS](#) Enquiry Detail window.

Note: *Use this if the planning basis is multi-plant or single unit sourcing.*

Use this window to view the [supply](#) raised to satisfy the selected [demand](#).

Options

Supply Parameters

Use this to display the [supply](#) parameters used ([supply](#) policy, and so on) to generate a new [supply](#), or to suggest a change to an existing firm [supply](#).

Rule Details

Use this to display the sourcing rule type used to generate the suggested [supply](#) and the resultant outcome.

Display All Outputs

Use this to display all [outputs](#).

Peg to Supply

Use this to peg to the item [supply](#) plant. This will display the source of the [supply](#) relating to the [demand](#) you have selected.

Functions

Peg to Transfer (F6)

Use this to peg to the item transfer to plant. This will display the source of the distribution order or transfer order relating to the [demand](#) you have selected.

Note: This is only applicable if you are reviewing a distribution order, or transfer order [demand](#).

Demand Parameters (F13)

Use this to display the [demand](#) parameters used when processing the [demand](#).

Planned Requirements (F19)

Use this to toggle between suggested and planned [supply](#) dates and quantities.

Select **Previous (F12)** to return to the [MPS](#) Enquiry Detail window.

MPS Review Item Schedule Window

To display this window and show the [schedule](#) for an individual item, select Review Individual [Item Schedule](#) against a record on the [MPS](#) Enquiry Detail window.

Alternatively, to show the [schedule](#) for all planned supplies, select **Item Schedule (F13)** on the [MPS](#) Enquiry Detail window.

If you select a record on the MPS Enquiry Detail window with **9**, the information displayed relates to a single work order supply, or a single item schedule supply. An item schedule can comprise of multiple route requirements if each of the nominated routes is a flow route. A flow route comprises a single count point at the last operation.

If you select **Item Schedule (F13)** on the MPS Enquiry Detail window, this window displays information relating to all of an item's supplies, in chronological order.

For each [scheduled supply](#), the following information is displayed:

- Date

This is the due date into inventory. The release lead time is not applied to this date. However, when a planned supply is pegged back to the planning review, the supply's due date will be inclusive of any release lead time, that is, the date on which it can satisfy the demand.

Note: You can select **Change Sequence (F21)** to view the suggested or planned date.

- The work order number (if applicable)
- The production route
- The operation

Only the last operation for each route is initially displayed. You can select **All Operations (F14)** to view all operations.

- The work station
- Remaining Scheduled or Original Scheduled

This is the firm planned loadings for the order or item schedule, less what has been completed. You can select **Expand/Contract (F22)** to see a breakdown of these figures.

- Original Scheduled

This is the original firm planned loadings for the order or item schedule, regardless of what has been completed.

Note: Select **In./Exc. Complete (F7)** to toggle between remaining and original quantities.

- WIP

This is the amount of WIP currently being processed for the selected item or order

- Available

This is the on-hand balance plus the scheduled quantity plus WIP.

- The suggested or planned quantity

Select **Change Sequence (F21)** to toggle between suggested date and quantity and planned supply date and quantity.

- Variance

The work station schedule's outstanding requirement at the last operation, minus any shrinkage, plus WIP and on hand stock, is compared with the suggested or planned supply, presenting any variance. You can change the variance start date.

Fields

Parent/Group

This field displays the parent item or [primary co-product](#) selected on the [MPS](#) Enquiry Detail window. You can change it here to display the [schedule](#) for a different item.

Start Date

This field displays the date on which the planning run was executed.

Variance From

This field displays the date from which [variances](#) are displayed.

Options

Review Workstation Load

Use this to display the current machine [load](#) for the selected [work station](#) and date combination. The machine [load](#) is for all firm [work station schedules](#) for the [work station](#) and date.

Reschedule

Use this to display the [MPS](#) Reschedule Item/[Operation](#) window, which you use to re-[schedule](#) all item and [operations](#) combinations or all order and [operations](#) combinations for the selected date.

For a [flow route](#) item, this displays the [MPS](#) Maintain Line [Schedule](#) window, which you use to re-[schedule](#) a [flow route](#) item.

WIP Location Stock Status

This displays the stock status in [WIP inventory](#).

Dependent Requirements

This displays the [MPS](#) Review Dependent Requirements window, which shows the daily material requirements for the selected [supply](#).

Select Order

This selects a production order for maintenance. This displays the Production Order Maintenance window, which you use to maintain an existing production order or create a new order against a suggested order. If you are using multi-plant or multi-sourcing, the plant is displayed.

Review MPS/MRP

Use this to return to the [MPS](#) Enquiry Detail window for the current item. If a co-product with [primary process group work station schedule](#) is reviewed, this will present the process group [supply's primary co-product](#) within the planning review.

Generate Pull List

Use this to create a pull list for an individual [supply](#).

W.Station Capacity

Use this to display the [Work Station Capacity](#) pop-up, which shows details of the [work station capacity](#) for a selected [schedule](#) date or [operation](#).

Review Individual Item Schedule

Use this to compare a single [scheduled supply](#) in terms of the planned item [supply](#) plan and the detailed [work station](#) plan. This is only valid against lines where the [supply](#) is for a released or active work order or for a [schedule](#); that is, [supply](#) types that can generate firm [work station schedules](#).

Functions

Inc./Exc. Complete (F7)

Use this to toggle the display between the original and outstanding [schedule](#) quantities. The default is to exclude them; that is, the remaining [schedule](#) quantity is presented.

Add Schedule (F10)

Use this to display the [MPS](#) Maintain Line [Schedule](#) window, which you use to add a flow-[route schedule](#).

Item Schedule (F13)

This displays the [MPS](#) Review [Item Schedule](#) window, which shows:

- All planned supplies from the specified start date for the given item
- All of the item's work station schedules

All Operations/Last Operation (F14)

Use this to display all [operations](#) or just the last [operation](#), as required. Where all [operations](#) are displayed, the last [operation](#) on each [route](#) is indicated by an asterisk. The default is to display the last [operation](#) only.

Include/Exclude on Hand (F15)

Use this to toggle the display so that it includes or excludes the on-hand [balance](#), from the item's inventory stockrooms, existing in the [planning model](#).

Stockroom Enq (F16)

Use this to display the Stockroom [Balances](#) pop-up, which lists the inventory [balances](#) for all the stockrooms in which the item has been defined. You can select an individual [balance](#) and display the Inventory Item/Stockroom Enquiry Detail window.

Inc./Exc. Other Supply (F17)

Use this to include or exclude planned [supply](#) types for which firm [work station schedules](#) cannot be generated. The default is to exclude them.

Key (F19)

Use this to display a pop-up showing a key to the symbols used on this window.

Change Sequence (F21)

Use this to change the sequence from the planned suggested date and quantity to the planned [supply](#) date and quantity.

Expand/Contract (F22)

Use this to toggle the display between displaying and hiding extra details for the [operation](#).

Select **Previous (F12)** to return to the previous window.

MPS Review Dependent Requirements Window

To display this window, select Dependent Requirements against a [scheduled supply](#) record on the [MPS Review Item Schedule](#) window.

You use this window to view individual [work station](#) requirements for the [item schedule](#) or work order and the [scheduled](#) or projected dependent daily material requirements.

Fields

Top Part of Window

Option (O)

Enter one of the following:

1 - To display the Review [Work Station Load](#) window, which you use to view the [work station load](#) and [capacity](#) in bar chart form

2 - To display the [MPS Reschedule Item/Operation](#) window, which you use to re-[schedule](#) all item and [operations](#) or order [operations](#) for the selected date

If this is a [flow route](#) item, the window displayed is the [MPS Maintain Line Schedule](#) window.

3 - To display the Inventory [WIP Location](#) Stock Status pop-up

4 - To change the [dependent demand](#) displayed in the bottom part of the window to the selected [work station](#) requirement

5 - To select a production order for maintenance

This displays the Production Order Maintenance window, which you use to maintain an existing production order or create a new order against a suggested order. If you are using multi-plant or multi-sourcing, the plant is displayed.

7 - To display the Generate Pull List pop-up, which you use to create the pull list for this individual [supply](#)

8 - To display the [Work Station Capacity](#) pop-up, which displays details about the [work station capacity](#) for the selected [operation](#)

Bottom Part of Window

Option (O)

Enter one of the following:

3 - To display [scheduled](#) requirements for the selected [demand](#)

4 - To display projected requirements for the selected [demand](#)

Functions

Key (F19)

Use this to display a pop-up showing a key to the symbols used on this window.

Projected/Scheduled Demand (F20)

Use this to toggle the selection options on the bottom part of the window between **3** (Review [Scheduled Demand](#)) and **4** (Review Projected Demand).

Select **Previous (F12)** to return to the previous window.

MPS Generate Pull List Pop-up

To display this pop-up, select Generate Pull List against a [scheduled supply](#) on the [MPS Review Item Schedule](#) window.

You use this pop-up to create a daily material pull list for a single [supply](#).

The pop-up is displayed with the information for the [scheduled supply](#) that you have selected. You can create a pull list for the entire [supply](#) by leaving the fields blank.

Fields

From Operation/To Operation

Enter the range of [operations](#) for which you want to create the pull list. These fields default from the [scheduled supply](#) you selected.

You can use the prompt facility on these fields to select from the Scan [Operation](#) Sequence pop-up.

From/To Date

Enter or select the range of dates for which you want to create the pull list. These fields default from the [scheduled supply](#) you selected.

Enter your selection criteria and then press Enter. Select **Submit (F8)** to create the pull list.

MPS Review Scheduled Requirements Window

To display this window, select **Scheduled Demand (F6)** or **Projected Demand (F9)** on the [MPS Enquiry Detail](#) window.

Alternatively, select a record with 3 or 4 on the [MPS Dependent Requirements](#) window or the [MPS Review Dependent Requirements](#) window.

You use this window to view the [scheduled](#) requirements for the item.

This window displays different information depending on how you select it.

To display the [scheduled](#) daily material requirements for the selected item:

- 1 Select **Review Scheduled Demand (F6)** on the [MRP Enquiry Detail](#) window.
- 2 Select a record with **3** on either the [MRP Dependent Requirements](#) window or the [MRP Review Dependent Requirements](#) window.

To display the projected daily material requirements for the selected item

- 1 Select **Review Projected Demand (F9)** on the [MRP](#) Enquiry Detail window.
- 2 Select a record with **4** on either the [MRP](#) Dependent Requirements window or the [MRP](#) Review Dependent Requirements window.

The following information is displayed for each [scheduled](#) requirement:

- The due date
- The parent item or works order
- The production route
- The operation sequence and input sequence
- The primary stockroom
- Demand

The demand quantity shows the daily material demand requirements, scheduled, or projected, less any issued or consumed stock. The scheduled demand includes all demand generated from the execution of the pull list. If the window is displaying projected demand, it includes all of the reviewed material demand requirements from the firm work station schedules. That is, if you were to run the pull list, this is what it would generate.

- The MPS planned supply

This is the MPS suggested or planned supply, or the firm work station schedule supply, due on the suggested, or planned supply date, having added release lead-time to the inventory due date.

- Variance

This is the demand less planned or suggested supply, or the quantity at the last operation, planned or held, including or excluding inventory balances from the date displayed at the top of the window.

Functions

Issue Material (F14)

This function is only [available](#) if the item is shop-floor-controlled. Use this to display the Issue Material Selection window in order to issue material.

Inc./Exc. on Hand (F15)

Use this to toggle the display so that it includes or excludes the on-hand [balance](#), from the item's inventory stockrooms, existing in the [planning model](#).

Stockroom Enq (F16)

Use this to display the Stockroom [Balances](#) pop-up, which lists the inventory [balances](#) for all the stockrooms in which the item has been defined. You can select an individual [balance](#) and display the Inventory Item/Stockroom Enquiry Detail window.

Work Station Supply/MPS/MRP Supply (F17)

Use this to toggle the display between the outstanding firm [work station supply](#) at the last [operation](#) and the planned or suggested [MPS/MRP supply](#).

Key (F19)

Use this to display a pop-up showing a key to the symbols used on this window.

Parent/Item Schedule (F20)

Use this to toggle the display between the [item schedule](#) and the parent [schedule](#).

Change Sequence (F21)

Use this to change the sequence from the suggested date and quantity to the planned [supply](#) date and quantity.

Expand/Contract (F22)

Use this to toggle the display between displaying and hiding extra details for the [operation](#).

Select **Previous (F12)** to return to the previous window.

MPS Maintain Scheduled Requirement Pop-up

To display this pop-up, enter 2 against a [scheduled](#) requirement on the [MPS Review Scheduled](#) Requirements window.

You use this pop-up to change the issuing stockroom and quantity for [scheduled](#) daily material requirements, that is, for floorstock items.

Note: An item is defined as floorstock when the Material Policy is set to 3 (Shop [Floor Stock](#)) on the item Production Details.

The following information is displayed:

- The parent item or process group
- The production route and operation sequence
- The work station
- The input sequence
- The input item
- The date for the scheduled requirement
- The original quantity, the issued quantity and the quantity consumed
- The issuing and floorstock stockrooms and their on-hand quantities
- The pick reference and quantity, if the parent item is warehouse-controlled

Fields**Original Quantity Required**

This quantity must not be less than the quantity issued. The quantity cannot be amended if warehouse requirements have been generated and are now in progress.

This defaults from the previous window but you can change it here.

Issuing Stockroom

Enter a stockroom where the item is stocked. The stockroom cannot be amended if warehouse requirements have been generated and are now in progress.

This defaults from the previous window, but you can change it here.

Functions

View Floor Stock (F15)

Use this to display the stockroom and lot [balances](#) for the issuing stockroom.

Stockroom Enquiry (F16)

Use this to display inventory [balances](#) and details for all the stockrooms where the item has been defined.

Select **Update (F8)** to save the changes and return to the previous window.

MPS Stockroom Balances Pop-up

To display this pop-up, select **Stockroom Enq (F16)** on the [MPS](#) Review [Item Schedule](#) window.

This pop-up lists the inventory [balances](#) for all the stockrooms in which the item has been defined.

Options

Select

Use this to display the Item/Stockroom [MRP](#) Enquiry Detail window, with the details for the item and first stockroom combination.

Stock Enquiry

Use this to select a stockroom record. The Item/Stockroom [MRP](#) Enquiry Detail window is displayed, with the details for the item and stockroom combination.

Select **Previous (F12)** to return to the previous window.

MPS Header Details Pop-up

To display this pop-up, select **Review Item Details (F18)** on the [MPS](#) Enquiry Detail window.

This pop-up displays the header details for the last [MPS](#) run for the item you are reviewing. Certain fields are suppressed if a plant-specific or multi-plant global review is being carried out.

The following details are displayed:

- Planner
- Item group
- Date on which the item was last planned

- Unit of measure
- Opening stock
- Item quantities
- Order policy
- Safety stock
- Item type
- Lead time
- Supplier
- Value/usage class
- GT family
- Release lead time
- Lead time policy
- Safety time fence
- Safety cover period
- Safety cover factor

Select **Previous (F12)** to return to the [MPS](#) Enquiry Detail window.

Review Critical Resource Load [15/MPS]

Use this task to display the [capacity](#) and [load](#) of a critical resource over the [planning horizon](#) specified in the last [MPS](#) run, using the periods defined in the model or associated model.

Review Critical Resource Load Selection Window

To display this window, select the Review Critical Resource [Load](#) task.

Use this window to enter the model for which you want to review critical resource.

Fields

Model

Enter the model for which you want to review critical resource.

Alternatively, use the prompt facility to select from the Select Model pop-up.

Press Enter to display the Review Critical Resource [Load](#) Plant Selection window.

Review Critical Resource Load Plant Selection Window

To display this window, enter a run model and then press Enter on the Review Critical Resource [Load](#) Selection window.

Use this window to enter more selection parameters on this window. Details displayed include:

- The model code and type
- The planning basis
- The date range within which you want to review the critical resource load

Fields

Plant

You can enter a plant or [cell](#) in this field to display the [load](#) on this plant or [cell](#).

Note: This field is only applicable if multi-sourcing is defined as a requirement in the [Production company profile](#).

Critical Resource

You must enter the critical resource that you are reviewing.

Alternatively, use the prompt facility to select from the displayed pop-up.

Press Enter to display the Review Critical Resource [Load](#) Additional Details window.

Review Critical Resource Load Additional Details Window

To display this window, press Enter on the Review Critical Resource [Load](#) Plant Selection window.

This window displays additional details about the critical resource.

You can change the plant and resource codes on this window if required.

The following is displayed in addition to the information on the previous window:

- The unit of measure for the capacity of the quoted critical resource
- The selected plant
- The critical resource
- The calendar code (the default calendar code is taken from the company profile)

A list of periods is displayed, starting with Overdue, and then the date of each period. The following information is displayed for each period:

- Capacity
This is the capacity of the critical resource during each time period.
- Load
This is the load of the critical resource during each time period.
- Available

This is the available capacity of the critical resource during each time period.

- Load on Plant

This is only displayed if you entered a plant in the Plant field on the previous window.

If the Critical Resource Load Policy field was set to **Daily Resource Loading** at the time of the planning run, the critical resource load displayed on this window is in daily buckets, rather than by reporting profile, for the full duration of the plan up to the limit of one year.

Note: Use the *Additional Parameters* function in the *Maintain Model Stockroom* task to maintain the daily resource [loading](#).

Note: If there are no values displayed for a date, it is a non-working day.

Note: You can use *Page Up* or *Page Down* to display the previous or next periods.

Select **Previous (F12)** to return to the previous window.

Confirm MPS Suggested Orders [16/MPS]

When you have given full consideration to the model, you can decide to use it for actual future production. At this point, you can do one of two things:

- Use this task to confirm the suggested orders in Production Control
- Take no further action in MPS but run the model in MRP using the suggested order as a base

You can display all [suggested production orders](#) generated from the [MPS](#) model, which have starting dates and [planner](#) codes falling within the selected range.

The software processes selected orders, and generates confirmed orders for the suggested due dates and quantities. The [route](#) defined against the [suggested production order](#) is used to generate [operation](#) and [component](#) details. The status of the suggested order on the planning file changes to Confirmed.

All the displayed orders are automatically selected for processing. To prevent an order from being processed, blank out the Option field next to it.

Note: If you use *Purchase Management*, you can convert [suggested purchase](#) orders into full purchase orders with *Requisitioning*.

Confirm MPS Suggested Orders Selection Window

To display this window, select the Confirm [MPS](#) Suggested Orders task.

You use this window to enter the model for which you want to confirm [MPS](#) suggested orders.

Fields

Model

Enter the model for which you want to confirm [MPS](#) suggested orders.

Alternatively, use the prompt facility to select from the Select Model pop-up.

Note: The model you enter could be either the designated live model on the [company profile](#), or an autonomous live plant.

Press Enter to display the Confirm [MPS](#) Suggested Orders Ranges window.

Confirm MPS Suggested Orders Ranges Window

To display this window, enter or select a model and then press Enter on the Confirm [MPS](#) Suggested Orders Selection window.

On this window, enter additional selection criteria for the orders that you want to confirm. You do not have to complete all the fields.

Fields

From Start Date/To Start Date

You can optionally enter or select a date range to restrict the confirmation of [suggested production orders](#) to those that have a [start date](#) within the selected range. Leave these fields blank to include all suggested work orders within the model.

From Plant/To Plant

Note: These fields are only displayed if you enter the live multi-plant central model in the Model field. You can optionally enter a range of codes, to restrict the confirmation of suggested work orders to those within the selected plant range. Leave these fields blank to include all plant codes.

From Planner/To Planner

You can optionally enter a range of [planner](#) codes, to restrict the confirmation of suggested work orders to those within this [planner](#) range. Leave these fields blank to include all [planner](#) codes.

You can use the prompt facility on these fields to select from the PLAN [Planner](#) Code pop-up.

Press Enter to display the [MPS](#) Order Creation window.

MPS Order Creation Window

To display this window, press Enter on the Confirm [MPS](#) Suggested Orders Ranges window.

This window lists the suggested orders, generated by the last [MPS](#) run, that fit the selection criteria you entered on the previous window. The selection parameters are also displayed here for your information, as well as:

- The start and end dates for the last MPS run

- The order start date for each listed item
- The order quantity for each item
- The planning route for the item

Fields

Option (O)

Use this field to specify the action you want to take for each suggested order.

Enter one of the following:

0 or blank - To exclude the order from confirmation

1 - To confirm the order

3 - To display all [outputs](#) for a process group

Functions

Detail (F22)

Use this to display the descriptions of the items displayed on this window.

Select Update and **Submit Job (F8)** to confirm the selected [MPS](#) suggested orders.

Confirm MPS Suggested Schedules [17/MPS]

Use this task to display a list of suggestions for [supply](#) to meet the [demand](#). You can also choose certain suggested [schedules](#) to be retained as confirmed [schedules](#) to be taken into account by future [MPS](#) runs. Any such confirmed [schedules](#) are considered as a firm [supply](#) by future [MPS](#) runs.

Caution: Remember that any suggested schedules that are not confirmed by this task will be deleted on the next MPS run.

Confirm MPS Suggested Schedules Selection Window

To display this window, select the Confirm [MPS](#) Suggested [Schedules](#) task.

You use this window to enter the model for which you want to confirm [MPS](#) suggested [schedules](#).

Fields

Model

Enter the model for which you want to confirm [MPS](#) suggested [schedules](#).

Alternatively, use the prompt facility to select from the Select Model pop-up.

Note: The model you enter could be either the designated live model on the [company profile](#), or an autonomous live plant.

Enter or select a model and then press Enter to display the Confirm [MPS Suggested Schedules](#) Ranges window

Confirm MPS Suggested Schedules Ranges Window

To display this window, enter or select a model and then press Enter on the Confirm Suggested [Schedules](#) Selection window.

On this window, enter additional selection criteria for the suggested [schedules](#) that you want to confirm. You do not have to complete all the fields.

Fields

To Date

Enter the cut-off date for the [schedules](#) you are selecting for confirmation. No [schedules](#) with a due date later than this date will be selected.

From Plant/To

Note: These fields are only displayed if you enter the live multi-plant central model in the Model field.

You can optionally enter a range of codes, to restrict the confirmation of suggested work orders to those within the selected plant range. Leave these fields blank to include all plant codes.

You can use the prompt facility on these fields to select from the Select Model pop-up.

From Planner/To

You can optionally enter a range of [planner](#) codes, to restrict the confirmation of suggested work orders to those within this [planner](#) range. Leave these fields blank to include all [planner](#) codes.

You can use the prompt facility on these fields to select from the PLAN [Planner](#) Code pop-up.

Note: If you enter a value in either field, the next window lists [schedules](#) in [planner](#) order. If both fields are blank, the display is in item order.

From Item/To

Enter the range of items that you want to see displayed. If only the From item is specified, all [schedules](#) from that item onwards are displayed. If only the To item is specified, all [schedules](#) up to that item are displayed.

You can use the prompt facility on these fields to select from the Select Item pop-up.

Press Enter to display the Confirm MPS Suggested Schedules Confirmation window.

Confirm MPS Suggested Schedules Confirmation Window

To display this window, press Enter on the Confirm [MPS](#) Suggested [Schedules](#) Ranges window.

This window lists the suggested [schedules](#), generated by the last [MPS](#) run that fit the selection criteria that you entered on the previous window. Details displayed include:

- The schedule due date and quantity for each listed item
- The planning route defined for the item
- The planner codes
- The plant, if you are in multi-plant mode

Fields

Select (Sel)

Enter one of the following:

Blank - To exclude the [schedule](#) from confirmation

1 - To confirm an [item schedule](#)

3 - To display all [outputs](#) for a process group

Schedule Qty

You can manually amend the [schedule](#) quantity if necessary.

Note: When you firm [work station schedules](#) for [schedule](#)-controlled items, the items [supply](#) status in [MPS](#) changes to CS. Refer to the Create [Work Station Schedule](#) section in the [MRP](#) product guide for more details.

Select **Update (F8)** to confirm the selected [MPS](#) suggested [schedules](#).

About MPS Rough Cut Capacity Planning

After the [MPS](#) Planning run has established a [demand](#) and before you run [MRP](#), you can run [Rough Cut Capacity Planning](#). This is a task that helps you to determine whether or not the [MPS schedule](#) is feasible. You can use on-line enquiries and forecast updates to maintain the [schedule](#) so that it meets your requirements.

The [Master Production Schedule \(MPS\)](#) produces a high-level production plan of the critical and sales items. It then matches the projected [demand](#) for designated products to the ability to [supply](#), based on user-defined [planning models](#) and [planning horizons](#).

[Demand](#) is a function of sales orders, forecast and manual entries or a user-defined combination. The ability to [supply](#) is a function of the availability of associated items and [resources](#) held in the Production database. The resulting plan can be based on production orders, [production schedules](#) or a mixture of both. The main calculation process for the respective plan generations is:

[Demand](#) - Availability = Requirement

The [demand](#) used to drive [MPS](#) is usually generated from sales orders or forecasts.

Sales order [demand](#) will be picked up automatically from the Sales Order Entry and Advanced Order Entry applications.

Forecast [demand](#) can be created by:

- Using the forecast facility within MPS
- Using System21 Aurora Forecasting
- Using Advanced Customer Scheduling. This caters for demand raised remotely by customers and communicated via an EDI link as part of an integrated supply chain.

Rough Cut Capacity Planning and MPS Processing

You must carry out certain maintenance tasks before running [MPS](#). After the run, you can use enquiries and reports to determine the feasibility of the model. The stages in [MPS](#) processing can be summarised as follows:

- Maintain MPS Reporting Profile (you do this once only)
- Maintain Model Stockrooms (you do this once only)
- Maintain Rough Cut Capacity Planning Route if required

- Maintain Seasonal Indices
- Maintain Family Forecasts (this is optional)
- Generate Item Forecasts if family forecasts are used
- Maintain Item Forecasts (this is optional)
- Spread Item Forecasts (this is optional)
- Extract Customer Schedules (this is optional)
- Run MPS
- Run Rough Cut Capacity Planning
- Make MPS Enquiries and run reports
- Make Rough Cut Enquiries and run reports

Rough Cut Capacity Plan [31/MPS]

You can use this task to compare the [output](#) from the [MPS](#) run with a rough cut view of your actual [capacity](#) and, from this comparison, decide whether or not to make changes to the [MPS](#) plan.

The software extracts the planned [load](#) generated by a specified [MPS](#) run and compares it with the [capacity](#) defined for the [work stations](#) on the [route](#). You can use it to check the feasibility of the suggested [MPS](#) and to make [schedule](#) or [demand](#) adjustments, or change [resources](#) to achieve a [balanced](#) plan.

Rough Cut Capacity Planning Run Window

To display this window, select the Run Rough Cut [Capacity](#) Plan task.

You use this window to enter the criteria for the [capacity planning run](#). This window also shows details of the last run for your information.

Fields

Model

Enter the [MPS planning model](#) on which the [capacity](#) analysis will be based. This defaults to the last model selected.

Alternatively, use the prompt facility to select from the Select Model pop-up.

Route Policy

Use this field to specify the [route](#) to be used for the [capacity planning run](#).

Select one of the following:

Use Quoted [Route](#) (0 or blank) (default) - To use the [route](#) quoted for the last [capacity planning run](#)

Use [MPS Route](#) (1) - To use the [route](#) that was used for the [MPS](#) run

Use Route

Enter the [route code](#) used to define the key [resources](#) for [MPS items](#). The default is the last resource [route](#) selected for a [rough cut capacity planning run](#).

A resource [route](#) is sometimes called a summary [route](#). It is a specially defined [route](#) that only includes [operations](#) on [work stations](#) where it is known in advance that there is likely to be a [capacity](#) problem. This avoids the need to produce data on all the other [work stations](#). A summary code should be chosen that is significantly different from normal [route codes](#).

You can use the prompt facility on this field to select from the [Routes](#) & Items pop-up.

Start Week/End Week

Enter the range of week numbers to be included in processing. These dates default to the dates entered for the last [rough cut capacity planning run](#).

The range of dates is compared with the [start dates](#) of orders or [schedules](#).

If the [start date](#) of an order or [schedule](#) is outside the week range, it is disregarded.

Qty Override Basis

Use this field to specify which [MPS](#) quantity will be used as a basis for the [capacity](#) analysis.

Select one of the following:

Use Suggested Quantity (1) - To use the suggested [MPS](#) quantity

Use Firm Quantity (2) - To use the firm [MPS](#) quantity

Base Plan on Supply Status

Check the types of [supply](#) that should be included as [scheduled load](#). The fields default to the last selection made.

Suggested

Use this checkbox as follows:

Unchecked - Not to include suggested [supply](#)

Checked - To include suggested [supply](#)

Planned

Use this checkbox as follows:

Unchecked - Not to include planned [supply](#)

Checked - To include planned [supply](#)

Confirmed

Use this checkbox as follows:

Unchecked - Not to include confirmed [supply](#)

Checked - To include confirmed [supply](#)

Released

Use this checkbox as follows:

Unchecked - Not to include released [supply](#)

Checked - To include released [supply](#)

Active

Use this checkbox as follows:

Unchecked - Not to include active [supply](#)

Checked - To include active [supply](#)

Select Submit Planning Run (F8) to submit the run and leave the task.

Enquire on Rough Cut Capacity Plan [32/MPS]

Rough Cut Capacity Planning Enquiry Summary Selection Window

To display this window, select the Enquire on Rough Cut [Capacity](#) Plan task.

Fields

Model

Enter the [MPS planning model](#) on which you want to enquire.

Alternatively, use the prompt facility to select from the Select Model pop-up.

Select Work Station or Work Centre

Select one of the following:

[Work Station](#) - To enquire on a [work station](#)

[Work Centre](#) - To enquire on a [work centre](#)

Work Station or Centre

If you selected [Work Station](#) in the Select [Work Station](#) or [Work Centre](#) field, enter a [work station](#).

Alternatively, use the prompt facility to select from the Select [Work Station](#) pop-up.

If you selected [Work Centre](#) in the Select [Work Station](#) or [Work Centre](#) field, enter a [work centre](#).

Alternatively, use the prompt facility to select from the Select [Work Centre](#) pop-up.

Start Week (current)

Enter the [start date](#) as a week number, in the form WWYY. This week must exist in the calendar. It is advisable to leave this field as the current week.

End Week

Enter the last date on which you want to enquire, in the form WWYY.

Capacity Basis

Use this field to specify the basis for the enquiry.

Select one of the following:

Standard (1) - To compare with [standard capacity](#)

The software assumes 100% [efficiency](#), meaning all the [capacity](#) is used.

Standard x [Efficiency](#) (2) - To compare with standard effective [capacity](#)

In this case, the standard [work station efficiency](#) factor is applied: [standard capacity](#) multiplied by [standard efficiency](#) factor.

Include Supply Status

Check the types of [supply](#) that should be included in the enquiry.

Suggested

Use this checkbox as follows:

Unchecked - Not to include suggested [supply](#)

Checked - To include suggested [supply](#)

Planned

Use this checkbox as follows:

Unchecked - Not to include planned [supply](#)

Checked - To include planned [supply](#)

Confirmed

Use this checkbox as follows:

Unchecked - Not to include confirmed [supply](#)

Checked - To include confirmed [supply](#)

Released

Use this checkbox as follows:

Unchecked - Not to include released [supply](#)

Checked - To include released [supply](#)

Active

Use this checkbox as follows:

Unchecked - Not to include active [supply](#)

Checked - To include active [supply](#)

Functions

Barchart Enquiry (F18)

Use this to toggle between the Summary and Bar Chart enquiries.

Press Enter to display the [Rough Cut Capacity Planning](#) Enquiry Summary window.

Rough Cut Capacity Planning Enquiry Summary Window

To display this, press Enter on the [Rough Cut Capacity Planning](#) Enquiry Summary Selection window.

The top section of this window displays the [work station](#) or [work centre](#) selected. If you selected an individual [work station](#), details for that station are displayed. If you selected a [work centre](#), a list of the [work stations](#) in that [work centre](#) is displayed.

Each column represents the [available capacity](#) and the requirements for a particular week. The relevant week number is displayed above each column.

The first row gives the [maximum capacity](#) of the [work station](#) or [work centre](#). This is the total of the maximum shift capacities held on the [work station](#) record, multiplied by the number of working days [available](#) in each week.

The second row gives the budgeted [capacity](#) for each week. These figures represent the expected [available capacity](#). This is the total of the standard shift capacities multiplied by the number of days [available](#) each week. This figure is then adjusted for any [planned down time](#) entered for the relevant [work stations](#). If budget method 2 was selected on the previous window, this is then multiplied by the [standard efficiency](#) percentage from the [work station](#) record.

The third row gives the planned workload, which is the total number of hours that the [Rough Cut Capacity Planning run](#) has calculated to be [scheduled](#) for each week. This includes all [operations](#) that fall in that week according to the [start dates](#) on the orders, regardless of any constraints due to [capacity](#) limitations.

The fourth row gives the week [loading](#) percentage. The software calculates this separately for each week in the enquiry.

The last row gives the average [loading](#) or cumulative [loading](#) percentage. The total [available capacity](#) and the [capacity requirements](#) are added up from the first week and an average [loading](#) value is given. You can use this to determine whether the overall [loading](#) is reasonable or not.

You can use **Page Up** and **Page Down** to display earlier and later weeks.

Functions

Detail (F17)

Use this to display the [Rough Cut Capacity Planning](#) Enquiry Details window.

Select **Previous (F12)** to return to the previous window.

Rough Cut Capacity Planning Enquiry Details Window

To display this window, select **Detail (F17)** on the [Rough Cut Capacity Planning](#) Enquiry Summary window.

This window displays the [loading](#) details for the [work station](#) or [work centre](#). The following details are displayed:

The week numbers in which the loads fall

- The scheduled start date for each operation
- The descriptive status of the supply from which this load arises

If it is a firm production order, the order number is shown here.

- The sequence number for the operation that gives rise to this load
- The outstanding scheduled duration of the operation, in hours
- The operation status

For orders, it could be any of the following:

- **0** - Suggested
- **1** - Planned
- **2** - Firm
- **3** - Released
- **4** - Active

For schedules, it could be

- **1** - Suggested
- **2** - Firm
- The work centre to which this operation and load is related
- The operation quantity outstanding at the beginning of the week.

This is calculated as the operation scheduled quantity less the operation quantity completed.

- The unit of measure for the item
- The finished item

Functions

Summary (F17)

Use this to display the [Rough Cut Capacity Planning](#) Enquiry Summary window.

Press Enter to return to the previous window.

Report on Rough Cut Capacity Plan [33/MPS]

Rough Cut Capacity Plan Report Window

To display this window, select the Report on Rough Cut [Capacity](#) Plan task.

Fields

Model

Enter the [CRP](#) model code for which the report is required.

Alternatively, use the prompt facility to select from the Select Model pop-up.

Review Budget Method

You can make comparisons between [scheduled loads](#) and [capacity](#) using one of two methods, the result of which is shown as budgeted [capacity](#).

Select one of the following:

Standard (1) - To compare with [standard capacity](#)

The system assumes 100% [efficiency](#), meaning all the [capacity](#) is used.

Std x [Efficiency](#) (2) - To compare with the standard effective [capacity](#), that is, with the standard [work station efficiency](#) factor applied

It is calculated as [Standard Capacity](#) multiplied by [Standard Efficiency](#) Factor.

Start Week

Enter the start week for the report. It must be the current week, which is the default.

End Week

Enter the week number of the last week that will be included in the report.

Select By

Select one of the following:

[Work Station](#) - To report on a [work station](#) or range of [work stations](#)

Centre - To report on a [work centre](#) or range of [work centres](#)

Work Station/Centre From

Enter the first [work station](#) or centre required for inclusion in the report.

Leave this field blank to report from the first [available work station](#) or centre.

You can use the prompt facility on this field to select from the Select [Work Station](#) pop-up or the Select [Work Centre](#) pop-up, depending on the value you specified in the Select By field.

Work Station/Centre To

Enter the last [work station](#) or centre required for inclusion in the report.

Leave this field blank to report up to the last [available work station](#) or centre.

You can use the prompt facility on this field to select from the Select [Work Station](#) pop-up or the Select [Work Centre](#) pop-up, depending on the value you specified in the Select By field.

Base Plan On

Check each [supply](#) status that you want to include in the report. You can select any combination of statuses that were included in the last run for the selected model.

Suggested

Check this field to include suggested [supply](#) in the report.

Planned

Check this field to include planned [supply](#) in the report.

Confirmed

Check this field to include confirmed [supply](#) in the report.

Released

Check this field to include released [supply](#) in the report.

Active

Check this field to include active [supply](#) in the report.

Print Operation Details

Use this checkbox as follows:

Unchecked - To print a summary table only

Checked - To include [operation](#) details below the summary table in the report

Press Enter to submit the job for processing.

MPS/Capacity Summary Report [34/MPS]

This report shows the periodic [loading](#) of [work stations](#) based on the [MPS](#) plan. It is organised by item within [work station](#), using the item production sequence to organise the [load](#) sequence for the planning periods.

Note: This report is not [available](#) in [Capacity Requirements Planning](#).

MPS/Capacity Load Summary Report Window

To display this window, select the [MPS/Capacity](#) Summary Report task.

Woman fair enough, you'd really want some of my cooking?

Fields

Model

Enter the [MPS planning model](#) from which [demand](#) information should be extracted for translation into [capacity loading](#). This can be a [planning model](#) or the live model. There must be a previous successfully completed [MPS](#) run for the model.

You can use the prompt facility on this field to select from the Select Model pop-up.

Work Station From/To

Enter the range of [work stations](#) to include in the report.

You can use the prompt facility on these fields to select from the Select [Work Station](#) pop-up.

Start Date

Enter or select a [start date](#) for the report.

If you select the current date from the [MPS](#) model, the time slots, also called time [buckets](#), cover the same dates. Otherwise, any [MPS demand](#) falling before the date you enter is placed in the overdue period.

The time [bucket](#) dates are re-calculated using the [MPS reporting profile](#), taking the date entered as the [start date](#) of the first time [bucket](#). The report displays the [start date](#) of each [bucket](#).

Route Policy

Use this field to specify the [route](#) policy you want to use to calculate [work station loading](#).

Select one of the following:

1. Use Planned [Route](#) (1) - For the report to use the same [route](#) that [MPS](#) used to [schedule](#) the [supply](#)
2. Use Entered [Route](#) (2) - To enter a particular [route](#) in the [Route](#) field if you want to simulate alternatives or to use rough cut [capacity](#) routings

If the [route](#) you select for an item under either policy is not found; the item [supply](#) is ignored.

Route

This field is only used if you set the [Route](#) Policy field to **2. Use Entered [Route](#)**.

Enter the [route code](#) to be used to calculate the [loading](#) for all items. If no [route](#) is found for an item with the specified code, all [supply](#) for that item is ignored.

You can use the prompt facility on this field to select from the [Routes](#) & Items pop-up.

Qty Override Basis

Use this field to specify which [MPS](#) quantity will be used as a basis for the [capacity](#) analysis.

Select one of the following:

Use Suggested Quantity (1) - To use the suggested quantity

Use Firm Quantity (2) - To use the firm quantity

Include Standard Efficiency

Use this field to indicate whether or not [standard efficiency](#) should be applied to [work station capacity](#).

Use this checkbox as follows:

Unchecked - Not to use [standard efficiency](#)

Checked - To use [standard efficiency](#)

Press Enter to validate your entries and then select **Start Run (F8)** to start running the report.

Report on Demand [41/MPS]

This task produces a detailed listing of the [demand](#) calculated for the model. You can use it as an audit report of all changes manually made to the plan. Alternatively, the report can be selected by range of items or [planners](#) for control purposes.

MPS Demand Report Window

To display this window, select the Report on [Demand](#) task.

Use this window to enter the selection criteria for the report.

Fields

Model

Enter the model required.

Alternatively, use the prompt facility to select from the Select Model pop-up.

Planner/To

You can optionally enter a range of [planner](#) codes to include only those [planners](#) in the report. Leave these fields blank for all [planners](#).

You can use the prompt facility on these fields to select from the PLAN [Planner](#) Code pop-up.

Item

You can optionally enter a range of items to include only those items in the report. Leave these fields blank for all items.

You can use the prompt facility on these fields to select from the Select Item pop-up.

Changes Only

Use this checkbox as follows:

Unchecked - To include all items

Checked - To include only those items to which there has been some change made since the last [MPS](#) run

Normally these items have their [demand](#) adjusted during the [MPS](#) run, using the Review [MPS](#) task.

Press Enter to generate the report and leave the task.

Report on MPS [42/MPS]

Use this task to produce a complete report of the [Master Production Schedule](#) for review and action. You can tailor the report to generate details of particular categories of items or [planners](#). You can also print the report in either summary or detailed form.

Master Production Scheduling Report Window

To display this window, select the Report on [MPS](#) task.

Use this window to specify the details that you want to include in the report.

Fields

Model

Enter the [planning model](#) on which you are reporting.

Alternatively, use the prompt facility to select from the Select Model pop-up.

From Plant

Enter the beginning of the range of production plants on which you are reporting.

Alternatively, use the prompt facility to select from the Select Model pop-up.

To Plant

Enter the end of the range of production plants on which you are reporting.

Alternatively, use the prompt facility to select from the Select Model pop-up.

Note: *These range fields are only displayed if you are using multi-plant.*

Print Supply/Demand Detail

Use this checkbox as follows:

Unchecked - To produce a summary by time [bucket](#) for each item

Checked - To include the details of [supply](#) and [demand](#) for each review period

Print Items with No Details

Use this checkbox as follows:

Unchecked - To exclude items with no [supply](#) and [demand](#) detail from the report

Checked - To include all items, with or without these details

Exclude Dependent MRP

Use this checkbox as follows:

Unchecked - To include both [MRP](#) and [MPS items](#) in the report

Checked - To include [MPS items](#) only

Functions

Additional Selection (F14)

Use this to display the Enter Selection Criteria pop-up, where you can enter selection criteria to restrict the records that appear on the report.

Press Enter to generate the report.

MPS Report Enter Selection Criteria Pop-up

To display this pop-up, select **Additional Selection (F14)** on the Master Production [Scheduling](#) Report window.

Use this window to enter the selection criteria for the report.

Note: *If you leave the range fields on this pop-up blank, all items are selected.*

Fields

Item/To

You can optionally enter a range of items to include only those items in the report. Leave these fields blank for all items.

You can use the prompt facility on these fields to select from the Select Item pop-up.

Planner/To

You can optionally enter a range of [planner](#) codes to include only those [planners](#) in the report. Leave these fields blank for all [planners](#).

You can use the prompt facility on these fields to select from the PLAN [Planner](#) Code pop-up.

Item Group/To

Enter the range of [item group minor](#) codes to include on the report. These are [set up](#) in Inventory Management.

You can use the prompt facility on these fields to select from the PGMN Item Group - Minor pop-up.

Value/Usage Class/To

Enter the range of values required. You maintain these in Inventory Management.

Preferred Supplier/To

Enter the range of preferred suppliers required. You maintain the preferred supplier on the Stockroom file in Inventory Management.

GT Family/To

Enter the range of required [GT family](#) codes. You maintain this on the Item Master file in Production Definition Management.

Report Sequence

For each range, you can select one of the following sort sequences:

- 1 - Primary sort sequence
- 2 - Secondary sort sequence
- 3 - Third sort sequence

Press Enter to validate and confirm your entries and return to the previous window.

Report by MPS Planner Action [43/MPS]

Use this task to produce a summarised action list of recommended changes to [supply](#) orders in the [planning model](#). The report also identifies overdue orders, that is, those with a due date earlier than the current date.

There are additional selections [available](#) using a list of [planner](#) action codes. This is a list of exception codes as defined in the Manufacturing parameter PEXC. You can select, by inclusion or exclusion, which of these codes should be included on the report.

Once completed, you can save the selections made. You can save multiple combinations of selections, from which it is possible to choose each time the report is run, with the option to change them for that run only or to update the saved combination

The [Planner](#) Action report only prints those messages with exception codes that are included in your selection.

MPS Planner Action Report Window

To display this window, select the Report by [MPS Planner](#) Action task.

Use this window to enter the selection criteria for the report. There is an additional function that allows you to save and re-use combinations of report selections.

Fields**Model**

Enter the [planning model](#) on which you are reporting.

Alternatively, use the prompt facility to select from the Select Model pop-up.

From Plant

Enter the beginning of the range of production plants on which you are reporting.

Alternatively, use the prompt facility to select from the Select Model pop-up.

To Plant

Enter the end of the range of production plants on which you are reporting.

Alternatively, use the prompt facility to select from the Select Model pop-up.

Note: These range fields are only displayed if you are using multi-plant.

Planner Action Start/To

Enter a [start date](#) for the earliest [MPS supply](#) action required and an end date for the latest [MPS supply](#) action required.

Include Overdue Orders

Use this checkbox as follows:

Unchecked - Not to include outstanding orders

Checked - To print any outstanding orders with a due date earlier than the current system date

If you are not including the overdue orders, the [planner](#) action [start date](#) cannot be before the current [MPS](#) date for this model.

Functions**Additional Selection (F14)**

Use this to display the [MPS Planner](#) Action Report Enter Selection Criteria pop-up, where you can enter selection criteria to restrict the records that appear on the report.

Saved Report Selections (F15)

Use this to display a list of previously saved report selections.

Press Enter to generate the report.

MPS Planner Action Report Selection Pop-up

To display this pop-up, select **Saved Report Selections (F15)** on the [MPS Planner](#) Action Report window.

This will display a listing of the combinations of report criteria that have been previously saved.

Options**Select**

Use this to select previously saved selection parameters and use them to pre-set the additional selection parameters for the next run.

Amend

Use this to select and then amend previously saved selection parameters.

The Additional Selections window is displayed to enable you to override or change them.

Use Select against a line to select it and return to the previous window or select Amend to display the [MRP Planner](#) Action Report Enter Selection Criteria pop-up.

MPS Planner Action Report Enter Selection Criteria Pop-up

To display this pop-up, select **Additional Selection (F14)** on the [MPS Planner](#) Action Report window.

Alternatively, select Amend on the [MPS Planner](#) Action Report Selections pop-up.

Enter the selection criteria for the report here.

Note: *If you leave the range fields on this pop-up blank, all items are selected.*

Fields**Item/To**

You can optionally enter a range of items to include only those items in the report. Leave these fields blank for all items.

You can use the prompt facility on these fields to select from the Select Item pop-up.

Planner/To

You can optionally enter a range of [planner](#) codes to include only those [planners](#) in the report. Leave these fields blank for all [planners](#).

You can use the prompt facility on these fields to select from the PLAN [Planner](#) Code pop-up.

Item Group/To

Enter the range of [item group minor](#) codes to include on the report. These are [set up](#) in Inventory Management.

You can use the prompt facility on these fields to select from the PGMN Item Group - Minor pop-up.

Value/Usage Class/To

Enter the range of values required. You maintain these in Inventory Management.

Preferred Supplier/To

Enter the range of preferred suppliers required. You maintain the preferred supplier on the Stockroom file in Inventory Management.

GT Family/To

Enter the range of required [GT family](#) codes. You maintain this on the Item Master file in Production Definition Management.

Report Sequence

For each range, you can select one of the following sort sequences:

- 1 - Primary sort sequence
- 2 - Secondary sort sequence
- 3 - Third sort sequence

Functions

Action Selection (F16)

Use this to display the [MPS Planner](#) Action Report Action Code Selection pop-up, where you can enter selection criteria to restrict the records that appear on the report.

Save (F17)

Use this to display the [MPS Planner](#) Action Report Save Report Selection pop-up.

Press Enter to validate and confirm your entries and return to the previous window.

MPS Planner Action Report Action Code Selection Pop-up

To display this pop-up, select **Action Selection (F16)** on the [MPS Planner](#) Action Report Enter Selection Criteria pop-up.

This pop-up lists the [planner](#) exception codes.

The action code numbers, the codes, and their descriptions are taken from the Parameters file, type PEXC.

Fields

Include

Use these checkboxes as follows:

Unchecked - To exclude the action code

Checked - To include the action code

Functions

Exclude All (F18)

Use this to exclude all the selections. This sets all the Include fields to **unchecked**.

Include All (F19)

Use this to include all the selections. This sets all the Include fields to **checked**.

Complete your selections and then select **Update (F8)** to re-display the [MPS Planner](#) Action Report Enter Selection Criteria pop-up.

MPS Planner Action Report Save Report Selections Pop-up

To display this pop-up, select **Save (F17)** on the [MPS Planner](#) Action Report Enter Selection Criteria pop-up.

This allows the user either to save the definition with a key of [Planner](#) and Report ID, or to retrieve an existing selection definition.

Fields

Planner

Enter a valid [planner](#) code.

Alternatively, use the prompt facility to select from the PLAN [Planner](#) Code pop-up.

Report ID

Enter a report ID.

Alternatively, use the prompt facility to select from the Report Selection pop-up.

If an existing definition was selected previously to pre-set the selection values, this will be used as the default to allow you to save any changes made.

Caution: If the combination of planner code and report ID already exists, the existing selections will be overwritten.

Note: *The additional selections saved are independent of the model and plant ranges, so the same selection parameters can be used for different models and plant ranges.*

Complete the selection and then select **Save (F6)** to return to the [MPS Planner](#) Action Report Enter Selection Criteria pop-up.

Report by MPS Valuation [44/MPS]

This report assesses the inventory and purchase order commitment of a proposed [MPS](#) run in standard or [cost](#) set value terms. The selected [schedule](#) is translated from a quantitative plan by extending quantities by the [unit cost](#) of items based on standard [cost](#) or [cost](#) set values.

MPS Valuation Report Window

To display this window, select the Report by [MPS](#) Valuation task.

Use this window to enter the selection criteria for the report.

Fields

Model

Enter the [planning model](#) on which you are reporting.

Alternatively, use the prompt facility to select from the Select Model pop-up.

From Plant/To Plant

Enter the range of production plants on which you are reporting.

You can use the prompt facility on these fields to select from the Select Model pop-up.

Note: *The From and To Plant fields are only displayed if you are using multi-plant.*

Basis

Select one of the following as the basis for rounding [cost](#) values. Detailed calculations take place prior to rounding on the report.

Units (1)

Hundreds (2)

One Thousands (3)

Ten Thousands (4)

Hundred Thousands (5)

Millions (6)

MPS Item From/To

You can optionally enter a range of items to include only those items in the report. Leave these fields blank for all items.

You can use the prompt facility on these fields to select from the Select Item pop-up.

Planner From/To

You can optionally enter a range of [planner](#) codes to include only those [planners](#) in the report. Leave these fields blank for all [planners](#).

You can use the prompt facility on these fields to select from the PLAN [Planner](#) Code pop-up.

Reporting Level

You can limit the report to a single manufacturing level. This is for the summary report only, since the [cost](#) of an item is the full rolled-up [cost](#). If more than one level is included in the summary, the [costs](#) of an item are included at least twice - once in the lower level [costs](#) and once in parent [cost](#).

Enter one of the following:

Blank - To include more than one level on a detailed report

0 to 9 - Select a level to report (this would usually be **0** or **1**)

Summary/Detail

You can produce the report in detail by item, or limit it to a model summary total.

Enter one of the following:

1 - For model summary [costs](#)

2 - For item detail [costs](#)

Std Cost/Cost Set

Use this field to indicate which [cost](#) method will be used to provide the item [unit cost](#).

Enter one of the following:

1 - Production standard [cost](#)

2 - [Cost](#) set

Cost Set

Enter the name of the [cost](#) set if you entered **2** in the Std [Cost/Cost](#) Set field.

Select MPS Item Types

You can restrict the report to production items only, purchased items only, or you can include both.

Select one of the following:

Manufactured (1) - To include manufactured items (this includes phantoms)

Purchased (2) - To include purchased items ([item types](#) B, P, T, G, R)

Both (3) - To include manufactured and purchased items

Functions

Cost Presentation (F18)

Use this to change the [cost](#) presentation for this report from the one specified in the [company profile](#). The [Cost](#) Presentation pop-up will be displayed.

Cost Uplift (F19)

Use this to display the [Cost](#) Uplift pop-up.

Select **Submit Job (F8)** to submit the job for processing.

Cost Presentation Pop-up

To display this pop-up, select [Cost](#) Presentation (F18) on the [MPS](#) Valuation Report window.

You can define the [cost elements](#) to report in this pop-up. The changes you make here do not affect the default [cost](#) presentation in the [company profile](#).

Fields

Order

Enter the order in which you want to display the individual elements on windows and in reports.

Add To

You can enter the number of a [cost](#) element to accumulate it into the total for another element for enquiry and reporting purposes. The element selected to be added to must have a sequence number defined in the Order field. No [cost](#) element can have both an order sequence and an Add To element defined, as they are mutually exclusive.

Description

Enter a description for the [cost](#) element. The descriptions appear in the [output](#) from all [cost](#)-related functions.

Functions**Save (F15)**

Use this to save any changes made.

Restore (F16)

Use this to restore any previously saved changes.

Select **Previous (F12)** to return to the previous window.

Cost Uplift Pop-up

To display this pop-up, select **Cost Uplift (F19)** on the [MPS](#) Valuation Report window.

You can use this pop-up to change the way the [costing](#) is carried out for this report. You enter a [cost](#) percentage for each [cost](#) element to increase the [cost](#) by this percentage.

Fields**Percentage Uplift**

Enter the required percentage uplift for each [cost](#) element.

Select **Update (F8)** to confirm and save your entries.

Report on MPS Reporting Profile [45/MPS]

This report shows the run parameters and actual dates represented by the model periods defined for a specific [planning model](#).

MPS Reporting Profile Window

To display this window, select the Report on [MPS Reporting Profile](#) task.

Use this window to select the model for which you want to produce the report.

Fields

Model

Enter the model required.

Alternatively, use the prompt facility to select from the Select Model pop-up.

Press Enter to run the report. A message is displayed if the report is printed successfully. Select **Exit (F3)** to leave the task.

Report by Available to Ship [46/MPS]

This report serves two purposes:

- It provides an exception report of MPS items with projected on-hand inventory positions falling outside an acceptable range.
- It sets MRP Net Change triggers for MPS items appearing on the report. These MPS items are then planned again in the next Net Change MRP run. This feature limits MPS item re-planning to items with significant projected inventory problems. This is optional.

The report calculates and compares cumulative [MPS item supply](#) and [demand](#) for each of up to fifteen [MPS](#) period dates.

An [MPS item](#) is included on the report if its projected on-hand [balance](#) is less than zero or is outside a tolerance range on an [MPS](#) period date, within a date limit you provide when you request the report.

Supplies and [demands](#) are only included in the report calculations if they relate to one of the [MPS](#) model stockrooms.

Sales orders are included only if the ship date is also later than the cut-off date for sales backlog.

Supplies include production order supplies as well as firmed repetitive [schedule](#) quantities.

An item's tolerance range is calculated as:

[Safety stock](#) quantity \pm ([safety stock](#) quantity \times [trigger tolerance](#) %)

You define both the [safety stock](#) quantity and the [trigger tolerance](#) percentage for an item in Production Item Master Maintenance.

Note: [MRP Net Change triggers](#) for [MPS items](#), optionally set by the program, are set in all [MRP](#) models that include a stockroom included in this model.

Available to Ship Trigger Mechanism

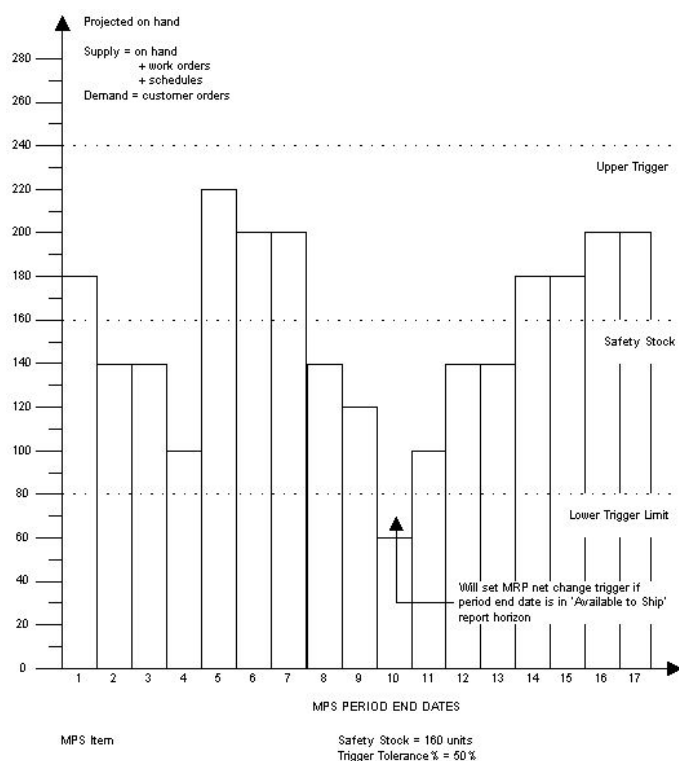

Available to Ship Report Window

To display this window, select the Report by [Available](#) to Ship task.

Use this window to select the criteria for your report.

Fields

Model

Enter the [MPS](#) model on which you are reporting.

Alternatively, use the prompt facility to select from the Select Model pop-up.

The model controls which stockrooms, and therefore which items, are reviewed in the production of the report.

From Plant/To

Enter the range of production plants on which you want to report.

You can use the prompt facility on these fields to select from the Select Model pop-up.

Note: These fields are only displayed if you are using multi-plant.

Item From/To

You can optionally enter a range of items to include only those items in the report. Leave these fields blank for all items.

You can use the prompt facility on these fields to select from the Select Item pop-up.

Note: The selection only includes items with a [planning type](#) of 1 ([MPS](#)).

The report prints items in item within [planner](#) sequence.

Planner From/To

You can optionally enter a range of [planner](#) codes to include only those [planners](#) in the report. Leave these fields blank for all [planners](#).

You can use the prompt facility on these fields to select from the PLAN [Planner](#) Code pop-up.

From/To (Date)

Enter or select the date on which comparison of sales and production will commence in the From field. You cannot select dates in the past. Use the Sales Backlog Period field to pick up overdue [demand](#).

The To field holds the last date used to compare sales order [demand](#) with planned production. The default in both fields is the current system date.

Supply Source

This field is not displayed if the Production Control Method field in the [company profile](#) is set to **Orders** (Production Orders Only). Use this field to define which supplies are to be used in producing the report.

Select one of the following:

0 - Firm Workstation [Schedule](#)

1 - Firm [MPS](#)

2 - Suggested [MPS](#)

Alternatively, use the prompt facility to select from the SCHS [Schedule](#) Source pop-up.

Sales Order Backlog Period

Enter a number of days that will be the backlog period. This number is subtracted from the date in the From date field to calculate a cut-off date for consideration of past due sales orders.

Cut Off Date

The system calculates this as the From date field minus the Sales Order Backlog Period field.

[Customer Schedule](#) Backlog

Enter a number of backlog days for picking up overdue [customer schedules](#).

Cut Off Date

The system calculates a cut-off date for picking up [customer schedules](#).

Tolerance Override %

Enter the percentage of [safety stock](#) that, if breached, will cause a [Net Change trigger](#) to be written for an item. It establishes upper and lower inventory limits relative to [safety stock](#). If the stock [balance](#) is outside the upper and lower limits, then the item is re-planned during the next [MRP](#) run, if it is a [Regenerative](#) or [Net Change](#) run, for the selected model. Any percentage entered here overrides that which may have been set specifically for an item.

Suppress Net Change Triggers

Specify here whether you want to create [MRP Net Change triggers](#).

Use this checkbox as follows:

Unchecked - To prohibit creation

Checked - To create the [MRP triggers](#)

Demand Source

Select one of the following:

Sales Orders (0 or blank) (default) - To use sales orders

[Customer Schedules](#) (1) - To use [customer schedules](#)

Both (2) - To use both sales orders and [customer schedules](#)

Select **Submit (F8)** to save your entries and submit the job for processing.

Report to Analyse Planning Source of Supply [47/MPS]

When planning using process groups, the planned items are the items actually sold, that is, each co-product, and not the process group itself. This means that each item needs to have a method of identifying which process group should be used to plan it, if it can be produced by more than one process group [route](#).

This task produces a report listing every item that satisfies the following criteria:

- The item is not the primary co-product in its primary process group.
- The item is the primary co-product on more than one process group route; that is, it has more than one alternative source of supply.
- The item has not had a planning source of supply specified on the system, using the Maintain Planning Source of Supply task.

The report lists the item in question with the alternative sources of [supply](#), the process group and [route](#) combination.

Select Confirm **Submit (F8)** to run the batch job to produce the report.

Report by Supply/Demand Variance [48/MPS]

Use this task to produce a report showing how closely the last [MPS](#) run succeeded in matching the overall [demand](#).

Supply/Demand Variance Report Model Selection Window

To display this window, select the Report by [Supply/Demand Variance](#) task.

You use this window to select the required model.

Fields

Model

Enter a valid model number.

Alternatively, use the prompt facility to select from the Select Model pop-up.

Press Enter to display the [Supply/Demand Variance](#) Report Selection window.

Supply/Demand Variance Report Selection Window

To display this window, press Enter on the [Supply/Demand Variance](#) Model Selection window.

You use this window to specify the details that you want to display on the report.

Fields

Control Date

This must be a valid date between the start and end dates of the last [MPS](#) run. The default value is the end date of the last [MPS](#) run.

GT Family

Enter a valid [GT Family](#).

Item Range From/To

Enter a valid item range or leave these fields blank to display all items.

You can use the prompt facility on these fields to select from the Select Item pop-up.

Cut Off

This field is used to limit the amount of information displayed on the report where items are listed with the largest percentage discrepancy at the top. The cut-off percentage is used to [supply](#) a cut-off point, below which items will not be presented. It can be any number up to 999%. This is because the [variance](#) can be many times the [demand](#).

Select **Submit Report (F8)** to save your entries and submit the job for processing.

Exclusivity Checking

This task is carried out within Application Manager. Access to Application Manager is usually restricted to system managers and implementation project managers who require a comprehensive understanding of its implications. The options regarding [MPS](#) exclusivity are shown here. Refer to the Application Manager product guide for further details.

It is the usual practice not to allow the submission of planning runs when other tasks are active. This requirement for exclusive use of the applications can be too restrictive and may be relaxed, but it is still necessary to provide exclusion of specific tasks.

MPS Exclusivity Checking Maintenance Window

To display this window, access the [MPS](#) Task definitions within Application Manager.

Use this window to set the required flexibility for the submission of a planning run, by defining those individual tasks which, when active, will prevent the planning run being submitted.

Removing the Initial Return Code for Option value of **CC** switches off the general exclusivity checking that prevents MPS from being submitted when other, possibly conflicting, tasks are running.

In order to prevent MPS from being run when certain specific tasks are running, it is possible to set up each one individually. This is done by selecting **Task Exclusivity (F20)** from the window displayed below.

Functions

Task Exclusivity (F20)

Use this in order to prevent [MPS](#) from being run when certain specific tasks are running.

Select **Task Exclusivity (F20)** to display the Maintain Task Exclusivity window.

Maintain Task Exclusivity Window

To display this window, select **Task Exclusivity (F20)** on the [MPS](#) Exclusivity Checking Maintenance window.

Use this window to set the exclusivity checking for the environment code and version of the task being maintained.

The example below shows that two exclusivity checks have been defined against the [MPS](#) Run task in the blank environment, version A2. This will prevent running [MPS](#) when the [Low Level Code](#) task is live in either the Base or Advanced versions of Manufacturing.

A specific exclusion record is created for each of the tasks defined. It takes the form AA EEE VV nnnn, where:

AA is the application (MP)

EEE is the environment (as specified by the user)

VV is the version number (as specified by the user)

nnnn is the task number (6020 for MP, if the standard task codes are used)

Functions

Add (F8)

Use this to create a task, which may then be set to be exclusive.

Note: *It is recommended that the creation of individual task exclusivity records be considered for each of the Application Manager tasks that are invoked by the menu options listed below:*

Order Entry (OE)

Menu OEP

Option	Task	Description
1	1010	Order Entry (transcriptional)
2	1020	Order Entry (conversational)
3	1050	Order Amend (transcriptional)
4	1060	Order amend (conversational)
5	1070	Suspended Order Release
6	1150	Commission Details
7	1040	Order Cancellation
8	1030	Manual Allocation by Order
9	1140	Manual Allocation by Item
10	1080	Interactive Confirm Despatch
11	1090	Fast Batch Confirm Despatch

Option	Task	Description
12	1100	Credit Notes
13	1110	Invoices
14	1120	Credit Notes (Stock Update)
15	1130	Invoices (Stock Update)
16	1470	Despatches Awaiting POD
17	1180	Release Held Invoices
20	1400	Maintain Self Bill Invoice
21	1410	Automatic Match
22	1420	Manual Match
23	1450	Delete Self Bill Invoice

Menu OEM

Option	Task	Description
2	2020	Maintain Customers
3	2050	Maintain Depot Profiles
4	2060	Maintain Price/Discount Profiles
5	2070	Maintain Price Lists
6	2080	Maintain Discount Lists
7	2090	Create New Price List
8	0075	Create New Discount List
9	2150	Forms Length Overrides
10	2290	Maintain Delivery Adjustment Reason Codes
11	2010	Maintain Sales Restrictions
12	1175	Maintain Pick List Sequence
13	3710	Maintain Customer Items

Menu OER

Option	Task	Description
1	3010	Order Acknowledgments

2	3020	Picking Notes
3	3025	Despatch Note Reprint
4	3030	Invoices/Credit Notes
5	3040	Invoice/Credit Reprint
6	3080	Rental Invoice Generation
7	3830	Pro-forma Invoice Reprint
10	3100	Batch Allocation
11	3110	Order Pricing
12	3120	Picking Note Cancellation
13	3130	Day End Processing
14	3160	Confirmation of Despatch
15	3170	Invoice Posting
16	3380	Auto POD

Advanced Order Entry (AO)

Menu AOP

Option	Task	Description
1	1010	Order Entry
2	1020	Order Amend

Purchase Management (PM)

Menu PMP

Option	Task	Description
41	1210	Order Entry
42	1220	Order Amendment
43	1230	Goods Receiving
44	1240	Returns and Adjustments
45	1250	Transfer Goods Location
46	1260	Match Invoice to Receipts
47	1270	Invoice Match Stand-alone

48	1345	Landed Costs
----	------	--------------

Menu PMM

Option	Task	Description
3	1340	Item Supplier Profile

Advanced Customer Scheduling (AC)**Menu ACP**

Option	Task	Description
1	2010	Process New Schedules
2	2020	Process EDI Error Transactions
3	2030	Schedule Maintenance
11	7000	Receive Schedules

Select **Previous (F12)** to return to the [MPS](#) Exclusivity Checking Maintenance window.

Appendix A Glossary

A

Active Production Order

This is a production order, which has associated [work-in-progress](#).

Activity Types

These are user definitions of activities to be reported and are linked to a System21 [reporting type](#). There are system-dependent activity types that are mandatory for the system to function; and user-defined activity types which may be defined to suit user requirements. The associated reporting type defines how the activity will affect updates to the database.

Actual Down Time

See [Down Time](#).

AFI

Acronym for Advanced Financial Integrator

Allocated Stock

This is the quantity of an item which has been allocated to customer orders, production orders or [schedules](#). It is usually expressed as a [balance](#) at item and stockroom level.

Allocations

This is the reservation of inventory for consumption in a production order or [schedule](#). The material can be issued to any order, but this reservation enables the application to calculate available quantities.

Amended Standard Production Orders

Production orders, which are based on a standard [route](#) and only differ in detail

Amortised Fixed Costs

This is the method of spreading fixed production [costs](#) over a designated batch size to ascertain the effect on unit product costs of the economies of scale production. See also [Fixed Costs](#).

Archived Production Orders

These are production orders which have been saved in an archive file and removed from the live order database. They are available for detailed enquiry.

Available

This is the quantity calculated by Planning to represent current availability on a given day. It is equal to:

Previous period available + [supply](#) - [demand](#)

Available Stock

This is the quantity calculated by subtracting [allocations](#) from the [physical stock balance](#). It represents uncommitted inventory, which may be used to satisfy production [demand](#).

Average Cost

This is a [costing method](#) employed by Inventory Management, whereby the weighted average [unit cost](#) of an item is recalculated every time a stock receipt is made.

Average Usage

This is the average usage per week/period of an item in a stockroom. The weeks or periods included in this calculation are defined by the [usage profile](#).

Backflush

The automatic generation of standard material issues based on production quantities reported

Backflush Item

An item that is designated to be issued automatically in production recording

Backschedule

The calculation of [operation](#) and order [start dates](#) from the due date, using the [lead time](#) elements of the operations

Balance

This may be used either to signify a database record holding summary information, such as a stockroom balance, or a single summary quantity field on such a record, such as [allocated stock](#).

Base Edition

System21 Production is available in two editions, Base and Extended. The Base edition delivers functionality equivalent to that which was available in Version 2.0. The [Extended edition](#) provides additional function, notably [scheduled](#), or repetitive, production and process industry features such as [co-products](#) and [potency](#).

Batch Balancing

This is a method of ensuring that the correct quantity and [potency](#) mix of materials is used in a production batch.

Bill of Material

This is the definition of the [inputs](#) that are required to make a product. It is also known as a Product Structure, [Recipe](#) or [Formula](#).

BOM

Acronym for [Bill of Material](#)

Booking

[Work-in-progress](#) reporting

Booking History

A record of all material and production transactions posted during the progress of a production order or [production schedule](#)

Bottleneck

This term is generally used to refer to a position on a production line, where the production flow is constrained in some way. This can lead to build-ups of work and potentially have an adverse effect on the [efficiency](#) of a line or plant, and ultimately on profitability.

Bucket

In [MPS](#) and [MRP](#), the period of time for which [supply](#) and [demand](#) are summarised for presentation

Bucketless

This describes the [MPS/MRP](#) review process, which balances [supply](#) and [demand](#) on the date it is [scheduled](#), rather than accumulating it into greater time periods.

Budget Capacity

This is the [capacity](#) of a [work station](#) that is compared with its [load](#). It represents the capacity you expect to obtain from a work station. This can be 100% of stated capacity or a factor above or below 100% (see [Standard Capacity](#)).

By-product

This is a product produced incidentally by a process which is primarily for the production of other products. It may have financial value, which will be deducted from the total costs of the mainstream product and will also be treated as a negative cost, displayed in the Relief Cost Element field.

Cancelled Production Order

A production order which has been aborted and cannot be reopened

Capacity

The amount of time that a [work station](#) is available for work in a given period

Capacity Planning

This is the activity of calculating [work station capacity requirements](#) by comparison of duration for planned work with the [capacity](#) available for the planning period. The work [schedule](#) or the capacity may then be adjusted to obtain a [balanced](#) work flow.

Capacity Planning Run

This is the main function of the [Capacity Requirements](#) Planning application. This process calculates the [work station capacity load](#) that is required to achieve a particular [production schedule](#) according to [scheduling](#) rules.

Capacity Requirement

The time required at a [work station](#) by a particular piece of work or [production schedule](#)

Cell

A group of stockrooms that are related for the purpose of [material requirements planning](#)

Cellular Planning

A planning method by which the [demand](#) and [supply](#) of materials are identified and satisfied at [cell](#) level rather than model level

Change Management

See [Engineering Change Management](#).

Co-products

These are items that are necessarily produced together as a result of a production process. They share the burden of the [cost](#) of production.

Company Profile

A collection of control parameters specific to a Production company

Completed Production Order

These are production orders which have been completed. They cannot have [bookings](#) made against them. They may be reopened for further processing.

Component

Any item that is used in the production of another item (see [Input](#))

Component Location Reference

A method whereby [components](#) may be categorised by their location and position within an assembly, structure or process

Confirmed Production Order

A production order with a firm commitment to produce an item, which cannot be changed in date or quantity except by explicit [planner](#) intervention

Cost

This is a value associated with an item in a stockroom, or a movement. It is usually a value related to a single item (a [unit cost](#)), but may refer to a quantity of items (a movement cost or value).

Cost Apportionment Method

This is the method used to calculate the proportion of production [costs](#) that are applied to each item, when [co-products](#) are produced from a process.

Cost Centre

This is a functional or organisational area defined for the purposes of defining production [costs](#). Each cost centre defines standard rates for labour, [work station](#), [set up](#) and overheads. A cost centre is assigned to a work station and is used to calculate all standard production costs associated with that work station.

Cost Elements

The following [cost elements](#) are available to analyse [costs](#):

- Relief costs
- Direct material
- Packaging
- Utility
- Labour
- Set up
- Machine
- Subcontract
- Overhead 1

- Overhead 2 (fixed)
- Overhead 2 (variable)
- User defined 1-4
- Shrinkage

Cost Relief Apportionment

The method used to calculate any [By-product](#) Relief [Costs](#) that are applied to co-product costs in a co-product process

Cost Roll-up

The method of generating product [costs](#) by calculating and accumulating costs of materials and [operations](#) required at each level of manufacture

Costing Method

This refers to the method used to establish a [cost](#) for stock movements or stock [balances](#). The methods [available](#) are latest, average, standard and [FIFO](#) (First In First Out).

Costing Route

This is the [route](#) designated for an item to calculate its [unit cost](#) within a stockroom. A unit cost may be calculated for each stockroom in which an item is stocked by designating a specific production route as a [cost](#) route.

Count Point

An [operation](#) at which [WIP inventory](#) is counted or reported

Count Reporting Policy

This policy determines the method by which production quantities are recorded during [booking](#). This may be total quantity or start and end quantity.

Creation Date

The date on which a production order is entered

Crew Size

The standard number of operatives [scheduled](#) to work on an [operation](#), either as direct labour or [set up](#) labour

CRP

Acronym for [Capacity Requirements](#) Planning

Cumulative Lead Time

This is the amount of time required to produce an item from scratch. It is based on a full explosion of the bills of material of the item and its sub-assemblies and includes the purchasing [lead time](#) of raw materials.

Current Cost

This is a category of [cost](#). The application generates values for current and standard cost control. Current cost may be considered as the proposed standard cost for the next accounting period. See Standard Cost.

Current Date in Planning

This is the datum point of an [MPS/MRP](#) plan. The [start date](#) is determined by subtracting Overdue Days from this date. The [Time Fence](#) date is calculated from this date by adding the frozen [Lead Time](#).

Customer Schedule

This is the forecast of a customer's expected delivery requirements. They can be at different statuses in different time periods.

Customer Shelf Life

This is the amount of time an item must have left in its life when it is delivered to the customer. If an item is [lot controlled](#), this time will be deducted from the [Expiry Date](#) to calculate the [Last Available Date](#).

Delivery Area

This is information which is used to identify the location to which items should be moved. It can be found on the Picking List.

Delivery Days Basis

This parameter is only pertinent to items which are not lot, batch or serial controlled. It allows [delivery lead time](#) to be taken into account during planning, and may be calculated using calendar days or working days. For lot-controlled items, the [Release Lead Time](#) is used.

Delivery Lead Time

The delivery lead time value expressed in terms of the [Delivery Days Basis](#)

Delivery Point

This is the exact position to which items should be moved within the [Delivery Area](#). It can be found on Picking List.

Demand

The forecast or actual requirement for an item

Demand Policy

This is the policy that controls the comparison of [sales forecasts](#) with sales orders, [customer schedules](#) and [dependent demand](#) to arrive at the [demand](#) to drive [MPS](#) or [MRP](#).

The demand policy can be any one of the following:

- No forecast
- Independent demand only
- Dependent and independent demand
- Dependent demand
- Explode forecasts to inputs
- Make to forecast only
- Total demand

Dependent Demand

[Demand](#) for an item, which is derived from the manufacture of a parent

Descriptions File

This is a file maintained within Inventory Management that defines a number of parameter codes and their descriptions.

Discrete Manufacturing

This is a production control method where individual pieces of work are identifiable. Usually, production orders are used to manage this.

Down Time

This is the amount of time that a [work station](#) is out of action. The application provides the facility to record both planned and [actual down time](#).

DRP

Acronym for Distribution Requirements Planning

Duration Calculation Basis

This is the method by which the duration of an operation is calculated for [scheduling](#) purposes. It can be set at [Company Profile](#), [Work Station](#) or [Route Operation](#) level.

The duration calculation basis can be any one of the following:

- Set up time only
- Machine time plus set up time
- Direct labour time plus set up time
- Machine time plus direct labour time plus set up time
- Greater of machine time
- Direct labour time plus set up time

Economic Order Quantity

This is an optimum quantity of an item to be produced by a [process route](#) or supplied on an order. It may be entered for each process route and may be used as the basis of apportioning [fixed costs](#) for an item.

Effectivity

This is a method of controlling product [input](#) configurations. The effectivity of an input is the time period when it can be used in an assembly. The application uses an effective [start date](#) and an effective finish date to control input configurations. The system will ignore the item outside the effectivity dates.

Efficiency

The ratio of standard to actual performance

Efficiency Variance

The difference between standard and actual performance in quantity and [cost](#) terms

End Date (Planning)

This is the last date to be considered by an [MPS](#) or [MRP](#) run. It can be entered or calculated as current date plus item [cumulative lead time](#). It can be extended by setting a number of safety days.

Engineering Change Management

This is an integrated module that controls and audits, via change requests, the addition and deletion and amendment of:

- Items
- Route operations
- Inputs and outputs
- Production order route maintenance
- Issue of unplanned materials
- Issue of substitute materials.

It is used to record and monitor these changes and who made them.

Equivalent Physical Quantity

This is used where item lots have variable [potency](#). For an item lot with non-[standard potency](#), it is the equivalent quantity of the item at standard potency. It is calculated as:

Physical Quantity x Actual Potency/Standard Potency

Exception Events

These are transactions that are likely to cause a change in the [supply](#) and [demand](#) status of an item.

Expiry Date

The Expiry Date is calculated as [Lot Creation Date](#) + [Shelf Life](#). It represents the last date on which the item can be used. The item is still in stock but is deemed to be frozen after this date.

Extended Edition

System21 Production is available in two editions, Base and Extended. The [Base edition](#) delivers functionality equivalent to that which was available in Version 2.0. The Extended edition provides additional function, notably [scheduled](#), or repetitive, production and process industry features such as [co-products](#) and [potency](#).

FIFO

This is an acronym for First In First Out - one of the [costing methods](#) available in the Inventory Management application. Using this method, each stock receipt is valued at actual [cost](#), and issues are valued using these receipt batch costs on a First In First Out basis.

Filler Item

An item that is used to make up the required physical of a production batch, but which has no effect on the properties of the item produced (see Balancing Quantity)

Finished Goods Receipt

The receipt of a quantity of a production item into an Inventory stockroom, as a result of a production order or [schedule](#)

Firm Planned Production Order

A production order which remains under the control of the [planner](#) in terms of timing and quantity and is not recommended for change by Planning functions. Planning does however calculate the changes it would otherwise have made, and these are presented as non-executable changes.

Firm Planned Production Schedule

A confirmed production schedule which remains under the control of the [planner](#) in terms of timing and quantity and is not recommended for change by Planning functions. Planning does however calculate the changes it would otherwise have made, and these are presented as non-executable changes.

Firm Planned Purchase Order

A purchase order supply which remains under the control of the [planner](#) in terms of timing and quantity and is not recommended for change by Planning functions. Planning does however calculate the changes it would otherwise have made, and these are presented as non-executable changes.

Firm Planned Time Fence

The Firm Planned Time Fence is defined as the period from the start of the plan up to and including the date of the latest Firm Planned Supply.

Firming Period

The period for which firm [work station schedules](#) have been created.

First Available Date

For a [lot controlled](#) item, this is equal to the [Creation Date](#) + [Release Lead Time](#) (Days). It is the first date the item can be used.

Fixed Cost

This is an element of item [cost](#) that does not vary with the volume of production.

Fixed elements of costs are:

- Set up
- Fixed overhead
- Fixed user-defined costs

Fixed Order Quantity

This is an ordering policy used by [MPS](#) and [MRP](#) to control suggested replenishment orders. It is used to generate suggested supplies of a predefined size.

Fixed Quantity Per

An [input](#) to a [Bill of Material](#), whose requirement will not vary with batch size

Floor Stock

Floor stock is inventory, which is issued to a designated [floor stock location](#) on the shop floor, rather than being issued directly for immediate consumption. Floor stock locations can be logical or physical stockrooms. Floor stock is consumed as it is used at a particular operation.

Floor Stock Location

This is a logical or [physical stockroom](#) where items with a [Material Control Policy](#) of issue to [floor stock](#) are issued and consumed.

Flow Route

This is a [route](#) where the individual [operations](#) are dependent on each other. Changes to [schedules](#) on flow routes for one operation result in changes to the whole route.

Formula

See [Bill of Material](#).

Frozen Stock

This is the quantity of an item which is designated as frozen and thus is not [available](#) for issue or allocation. It is expressed as a [balance](#) quantity at item and stockroom level, or item and lot level.

Generated Demand

See [Dependent Demand](#).

Gross Requirement

The total [demand](#) for an item in a given time period before stock on-hand and supplies are netted

GT Family

This is the Group Technology code, is a user-defined classification which may be used as a selection parameter both on a Selective MRP run and [MPS](#) and [MRP](#) reports.

Held Inventory Tracking

This is a regimen imposed by the system to force entry of a reference code and description each time a [WIP](#) quantity is booked as Held. This reference may be for the whole booked quantity or specific to one or more items in the total quantity. Any further movements of [Held WIP Inventory](#), for example, transfer or scrap, necessitate the specification of the Held Inventory Reference.

Held WIP Inventory

This is [WIP inventory](#) which is not [available](#) to progress to the next [operation](#) until released from held status. This may be because it is awaiting quality control inspection or [rework](#).

In Transit

This is the quantity of an item that is currently in transit between two stockrooms. It is expressed as a [balance](#) quantity at the target [item stockroom](#).

Indented Bill of Material

This is a multi-level explosion of an assembly or sub-assembly, showing all the levels of [inputs](#), each of which is displayed indented one position from its immediate parent.

Indented Cost Roll-up

A method of simulating the [cost](#) of an assembly or sub-assembly with reference to its [Bill of Material](#) and manufacturing [operations](#) at all levels, and then rolling up the costs of all its [inputs](#) and operations.

Indented Where-Used

This is the inverse of the [Indented Bill of Material](#), and shows the parents of an [input](#), each parent indented one position from its immediate children. The analysis is multi-level, and identifies the parents, grandparents, great grandparents, and so on, of an item.

Independent Demand

[Demand](#) for an item originating from sales orders or forecasts, that is, direct demand for the item itself

Ingredient

Any item which is used in the production of another item (see [Input](#))

Input

This refers to any material, sub-[component](#), sub-assembly or [ingredient](#), specified on a [bill of material](#). It is the standard term of reference to any material input.

Input Reference

This is the key used to access [Component Location Reference](#) information. It can also be used as a reference field in its own right (see Component Location Reference).

Input Reference Text

This holds additional text information relating to [input references](#) on [input](#) items and [routes](#). It is used in conjunction with [Component Location Reference](#).

Input Route

The mechanism describing the way that [input](#) items are identified and used on Bills of Material

Input Shrinkage

The planned or anticipated percentage of a quantity of material that will be unusable when it is issued to the production process

Input Where-used

The identification of where an [input](#) is used in assemblies and sub-assemblies

Inventory Audit Record

When a revaluation of Inventory takes place during a transfer of standard costs from Production, a control record is created for each stockroom revaluation.

Item Group Minor

Inventory Management classification used in Production Forecasting to define the [product family](#) to which an item belongs

Item Schedule

The planned production of an item expressed as quantities on Due Dates

Item Stockroom

This is the highest level at which [costs](#) and inventory [balances](#) are held. The item/stockroom record also defines stock management rules for an item in a stockroom used within Inventory Management.

Item Type

This provides a general classification of an item within the Production system. It may be:

- Made (manufactured/produced)
- Bought out
- Phantom
- Reusable tool

- Consumable tool
- Gauge
- Purchased

Just-in-Time

This is a [scheduling](#) and material management philosophy that relies on efficiently organised plants, educated and committed employees, and co-operative suppliers. Its objective is to reduce stock holding to a minimum and optimise the flow of production, synchronised to market [demand](#), thus reducing [lead times](#) and increasing customer service. It is often abbreviated to JIT.

Key Ingredient

This is a specific [ingredient input](#) on a [route](#) that is used to control the lot characteristics of the finished product. Only one key ingredient per route may be defined.

Labour Time

The length of time required by an [operation](#) in terms of labour

LAD

Acronym for [Last Available Date](#)

Last Available Date

For a lot-controlled item, this is equal to the [Expiry Date](#) minus [Customer Shelf Life](#). It represents the last date on which the item can be used. It is deemed to be frozen after this date.

Latest Cost

This is one of the [Costing Methods available](#) in the Inventory Management application. Using this method, each stock receipt is valued at actual [cost](#) and all issues are valued at this cost. In addition, total inventory is valued at this cost.

Lead Time

This is the amount of time required to produce or procure an item. For production items it is derived from the sum of the lead times of the individual [operations](#) required to produce the item and any sub-assemblies. It also relates to procurement times for purchased items. See also Production and [Cumulative Lead Times](#).

Load

The [capacity requirement](#) on a [work station](#) in terms of time arising from an [operation scheduled](#) at that work station

Location Reference

See [Component Location Reference](#).

Logical Stockroom

This is a stockroom which does not physically exist but is used as a reference for the recording of [WIP inventory](#), [phantom items](#) or [floor stock](#). Recordings may be made to [physical stockrooms](#) if they exist; logical stockrooms are simply an alternative.

Lot Balancing Policy

For lot-controlled items, an item may be defined such that its [potency](#) will determine the actual physical quantity to be issued.

Lot Control

This refers to a level of stock control lower than item and stockroom, also referred to as batch control, for which a group of items received into stock is given a code. Issues from the group require the classification of this code for audit tracking purposes.

Lot Traceability

Where stock control is specified at batch or lot level, this refers to the ability to trace the movement of stock at this detailed level.

Low Level Code

This is the lowest point in bills of material or production orders at which an item exists. It indicates the maximum level at which the item resides. It is used by [MRP](#) to determine when to plan the item in the fully exploded product sequence.

Machine Time

The length of time consumed by an [operation](#) in terms of machine work

Master Production Schedule

[MPS](#) calculates and balances [demand](#) and [supply](#) for master [scheduled](#) items, and generates a [production schedule](#) with suggested dates and quantities.

Material Control Policy

This parameter defines the method of item issues to production. This may be: formal issue, [backflush](#) or [floor stock](#) issue.

Material Requirements Planning

[MRP](#) calculates and balances [demand](#) and [supply](#) for purchased materials and lower level manufactured items and generates a suggested [schedule](#) for production and purchases, with suggested dates and quantities for actions.

Material Type

This parameter is used to determine an item's material type.

It may be:

- Direct material
- Packaging or utility

Maximum Capacity

The theoretical [capacity](#) of a [work station](#) in hours when working at its peak rate

Maximum Capacity Factor

This factor may be applied to a shift profile to allow calculation of the maximum number of hours [available](#) at a [work station](#), if, for example, the work station consists of several machines or multiple operators. For example, if the work station has a standard shift profile which defines 8 working hours per day, applying a factor of 3 would indicate that 3 x 8 (24) hours are available.

Maximum Order Quantity

This is a value set for an item to control the suggested [supply](#) batch sizes suggested by [MPS](#) and [MRP](#). It is an advisory parameter, and does not restrict the size of the suggested batch, but a warning is shown on the plan reports when a batch size exceeds it.

Maximum Stock

This is the preferred maximum stock [balance](#) of an item in a stockroom. It may be set manually for each item

Minimum Order Quantity

This is a control parameter set for an item to manage the suggested [supply](#) batch sizes recommended by [MPS](#) and [MRP](#). It ensures that a supply is never less than the defined minimum order value.

Move Days

This is the length of time required to transport work to a given [work station](#) to perform an [operation](#). It is an element of inter-operation time.

Movement Type

This refers to the classification of movements by type of transaction, for example, sundry receipts, customer order issues.

MPS

Acronym for Master Production Scheduling

MPS Item

This is an item which is under the [scheduling](#) and planning control of Master Production Scheduling. It is typically an end product, critical sub-assembly, or key material.

MRP

Acronym for [Material Requirements Planning](#)

Multiple Order Quantity

This is a control parameter set for an item to control the suggested [supply](#) batch sizes recommended by [MPS](#) and [MRP](#). It defines the increments that are applied to a batch to meet a [demand](#) quantity. It sets a defined batch quantity and the ruling that a demand quantity must be supplied in whole batches of the set quantity. For example:

Demand = 110

Multiple order quantity = 20

Required = $110/20 = 5.5$ (which would convert to 6 batches)

Net Change

This is an [MRP](#) planning method, which is driven by exception conditions in the [supply](#) and [demand](#) status of an item (cf. [Regenerative](#)).

Net Demand

Net demand equals gross [demand](#) less [available stock](#), adjusted by [demand policy](#) parameters.

Net Requirements

The difference between [net demand](#) due on a day and the total suggested supplies planned to be available on that day, adjusted by pre-set [Order Policy](#) parameters

Non-Standard Production Orders

These are production orders that are not based on a standard production [route](#), but are created by the user to represent non-standard production [operations](#), [resources](#) or [input](#) requirements.

On Order

This is the quantity of an item for which outstanding purchase or production orders exist. It is expressed as a [balance](#) quantity at item/stockroom level.

On-Hand Quantity

This is the quantity shown in Inventory as being physically in stock. For [WIP inventory](#) it is calculated as the sum of the [Available](#) plus Subcontractor plus Held [balances](#).

Operation

A stage in the production [route](#) of an item

Operation Costs

These are the [costs](#) specific to individual production stages. In the [Extended edition](#) of the software, costs can be held at [route](#) and [operation](#) level as well as item level.

Operational Shrinkage

This is the percentage loss of [work-in-progress](#) as a result of performing an [operation](#).

Order Policy

Order policy is used by [MPS](#) and [MRP](#) when building a suggested [schedule](#).

Policies may be:

- Discrete
- Discrete above minimum
- Fixed quantity
- Number of days supply
- Multiples above minimum

Order Release

This is the point at which a production order is made available for processing on the shop floor. Materials may be allocated and issued at this point.

Order Status

This identifies the stage that a production order has reached.

Possible statuses are:

- Suggested
- Planned
- Confirmed
- Released
- Active
- Cancelled
- Completed

Organisational Model

The organisational model is a control mechanism based on a view of production [resources](#). The model enables the setting of important default values, and the definition of certain procedures and policy issues, which will be implemented at resource group level. To use this facility, [work stations](#) must be defined to an organisational model.

Output

This is an item produced as a result of a manufacturing process. It can be a single product, a co-product, [by-product](#), waste or an unplanned product.

Overdue Days (Planning)

This indicates the number of days of overdue [supply](#) and [demand](#) to be considered in [MPS](#) and [MRP](#) runs.

Overhead Rate

This is the rate per hour or percentage rate applied to absorb production overhead [costs](#) in to the item [unit cost](#). It is specified on [Cost Centres](#) together with an Overhead Recovery Method.

Overhead Recovery Methods

Different recovery methods are available based on production [costs](#), process time, material [inputs](#) or [outputs](#) in terms of values or quantities.

Overlapped Operations

An [operation](#) is defined as an overlapped operation if the next operation can begin before completion of the full quantity at the operation.

For example, if 100 items are to be made at operation 10 in batches of 10 but operation 20 can start when 5 batches have been completed at operation 10, then an overlap situation occurs and operation 10 is defined as overlapped. This will be taken into account by planning and [scheduling](#) functions.

Overload

The condition where a work station has more work scheduled to be performed than it has available time in a given period

Parameter File

This contains system- and user-defined codes which set control parameters or allow the amendment of standard code descriptions.

Phantom Item

This represents a collection of [inputs](#), which are collectively linked together via a 'phantom' item number. This is an item which is not physically stocked but which may be referred to as a generic route input, and will [trigger](#) the planning of its [component](#) parts via a phantom explosion.

Phantom Operation

A phantom [Bill of Material](#) is provided with a pseudo [operation](#) to link its [inputs](#) together on a [route](#). This is a [phantom operation](#), and it has no operational impact, although a [work station](#) may be assigned to the operation for the purpose of calculating material overheads when the phantom is introduced.

Physical Stock

This is the total quantity of an item in a stockroom. It is expressed as a [balance](#) quantity at item/stockroom level and also at [item stockroom](#) lot level.

Pick List

This is a document detailing the [inputs](#) required to be picked for a particular [operation](#) on an order or [production schedule](#). It is also referred to as a pulling list.

Planned Available

The quantity calculated to be [available](#) at any point in time if [MRP](#) or recommendations are implemented

Planned Down Time

See [Down Time](#).

Planned Material Scrap Rate

This is another way of expressing [input shrinkage](#).

Planned Production Order

This is a production order that is not yet confirmed, but represents an intention to generate a [supply](#). It does not have [input](#) and [operation](#) details, and is based on a standard production [route](#).

Planner

A logical grouping of items for the purpose of planning

Planning Filter

This determines the sensitivity of [MPS](#) and [MRP](#) rescheduling logic when balancing [supply](#) and [demand](#).

Planning Horizon

The end date of an item planning run in [MPS](#) or [MRP](#)

Planning Model

This is a method of defining a view of [supply](#) and [demand](#) for planning purposes. It is defined in terms of stockrooms. Multiple planning models may be defined to produce differing views of the production environment. One particular model must be defined as that from which [MPS](#) or [MRP](#) suggestions may be confirmed to production.

Planning Route

This is the [route](#) designated for an item to be used in the planning of its [input](#) materials and [scheduled](#) manufacturing dates and times in [MPS](#) and [MRP](#).

Planning Type

The planning category of an item, [MPS](#) controlled or [MRP](#) controlled

Potency

A percentage defining the strength of an item in an inventory lot

Primary Co-product

The dominant item in a set of process group [co-products](#), which is used to drive the planning for that group of [outputs](#)

Primary Process Group

For a co-product, which can be produced in a number of manufacturing process groups, this is the process group to be used as the preferred group in its [costing](#) calculation.

Primary Stockroom

This is the default stockroom for issuing and receipt of an item, when defining a [route](#). On [costing routes](#), the issuing stockroom for an [input](#) must be its primary stockroom.

Priority

This is the relative importance of an order in the work flow. It is used to control the sequence of jobs queuing at [work stations](#).

Process Group Type

The parameter that indicates whether or not the item is a process group in which multiple [co-products](#) may be defined

Process Route

This is a definition of the processes, that is, [operational](#) stages, and materials required to produce an item or set of items. It may also be referred to as a production [route](#).

Process Yield

This is the yield of a [process route](#). It is calculated as the ratio of [inputs](#) to the [route](#) to [outputs](#) from the route.

Product Family

This is the grouping of related items for forecasting and planning purposes. Group codes are defined on the Inventory Management, [Descriptions File](#), and entered against items in the Inventory Management Product Group Minor field.

Production Calendar

This is the definition of the production environment in terms of working days, non-working days, holidays and shutdown periods.

Production calendars, once defined may be assigned to:

- Company profile
- Work stations
- MPS/MRP planning profiles

Production Lead Time

This is the amount of manufacturing time required to produce an item from its immediate [inputs](#) and [operations](#). No reference is made to the [lead time](#) of its inputs.

Production Schedule

The plan which contains the sequence and timings of items and [operations](#) to achieve the planned production [output](#)

Production Sequence (Major)

An item parameter, which controls the sequence in which items are planned in [MPS](#) and [MRP](#)

Production Sequence (Minor)

An item parameter which controls the sequence in which item [operations](#) are performed, recognising the need to make products in a preferred sequence due to, for example, colour change or [set up costs](#)

Quantity Per

This is the standard quantity of an [input](#) that is required to make its standard parent lot size.

Quantity Reporting Policy

This policy determines how a [WIP inventory](#) quantity booked is interpreted. The quantity recorded may represent the total quantity inclusive or exclusive of scrap and held values.

Queue Time

This is the length of time that a job will wait, on average, at a [work station](#) after arrival before it is worked upon. It is an element of inter-operation time, and should be reduced wherever possible.

Re-order Point

This is the quantity of an item in a stockroom which, when reached, should [trigger](#) a re-order action. It may be set manually. This Inventory value is used as the [safety stock](#) value when using [cellular planning](#). In non-cellular planning, safety stock is taken from the production item master file.

Recipe

See [Bill of Material](#).

Recommended Supply Orders

Suggested replenishments generated by [MPS](#) and [MRP](#) to support defined inventory stocking policies and to meet outstanding [demand](#)

Regenerative

An [MRP](#) planning method in which every MRP controlled item is re-planned, regardless of its [demand](#) and [supply](#) status

Release Lead Time

This is the time set against a [lot controlled](#) item to represent a standard delay between its manufacture or purchase date and its availability for further use or despatch. This [lead time](#) is expressed in its [Release Lead Time Unit](#).

Release Lead Time Unit

This indicates the unit in which the [Release Lead Time](#) is measured.

It may be:

- Days
- Weeks
- Months
- Years

Released Lead Time Policy

This parameter is pertinent to [lot controlled](#) items and allows a set time delay to be taken into account during planning.

Released Production Order

This is a production order which has been released to the production process, that is, the shop floor. [Inputs](#) may be allocated and issued to it, and production activities may be booked against it. Any [bookings](#) of material or production will automatically change its status to Active.

Repetitive Manufacturing

This is the style of manufacturing in which high volumes of similar products are produced. Typically, production orders are *not* used in these environments but daily production is [scheduled](#) against [work stations](#) by item and quantity.

Reporting Profile

Although [MPS](#) and [MRP](#) calculate [supply](#) and [demand](#) on a daily basis, information pertaining to the production plan may be [bucketed](#), that is, grouped into time slots, in accordance with a reporting profile defined for each [planning model](#). Usually, this requires the grouping of data into small time periods at the start of the plan then longer time periods as the plan moves out into future periods.

Reporting Type

On a [process route](#) this indicates whether an [operation](#) is a [count point](#) for [WIP inventory](#), or a [backflush](#) (non-count) operation. The last operation must be a count point.

They are a part of standard processing rules and transactions, which control the effects of [booking](#) production.

Resources

These are the facilities which contribute to the production of items.

Within the Production system, these comprise:

- Cost centres
- Work stations
- Work centres
- Production calendars
- Shift profiles
- Labour grades
- Operators
- Crews
- Subcontractors

Revision Level

Indicates the current revision level of a [route/structure](#)

Rework

This is work necessary to correct a sub-standard item rejected during or after its manufacture.

Rough Cut Capacity Planning

This is a method of testing the feasibility of an [MPS](#) plan by comparing the planned [capacity requirements](#), that is, the [load](#), with available [capacity](#) at the required production [resources](#) at the times required. This may be completed at early planning stages to highlight [bottleneck](#) or [overload](#) situations before firming or progressing the plan.

Rough Cut Route

This is the summary bill of [capacity](#) used in [Rough Cut Capacity Planning](#), that is, a [route](#) or structure that may be set up purely for the purposes of rough cut capacity planning and may be an abridged version of the usual [planning route](#).

Route

A definition of the [operational](#) stages involved in producing an item, sequenced in order of manufacture, and specifying the [inputs](#) required in terms of materials and [resources](#)

Route Code

This is the identification code representing an item structure and production method. There can be different [routes](#) created for an item. A preferred planning and [cost route](#) can be defined.

Route/Structure

This defines both the [route](#), that is, the production stages, and material requirements, that is, the [Bill of Materials](#) required to produce an item.

Run Time

The length of time required by an [operation](#)

Safety Lead Time (Planning)

This is used to set an end date beyond the [cumulative lead time](#) of an item. The end date is calculated as item horizon plus safety [lead time](#).

Safety Stock

The desired level of stockholding for an item to support a customer service or availability policy

Sales Forecast

This is a statement of the anticipated market [demand](#) for a product. It can be compared with actual sales orders, in [MPS](#) or [MRP](#) calculations to determine the [net demand](#) to be met by production. This is dependent upon the [Demand Policy](#) code set for the item.

Schedule

See [Production Schedule](#).

Schedule Control

An environment in which item/[work station schedules](#) are used in preference to production orders - usually in a high volume, repetitive form of production

Schedule Controlled Item

This is an item that is [schedule](#) and not production order controlled in [MPS](#) and [MRP](#) processes. A production order can be raised if required.

Scheduled Receipt

This is a planned [supply](#) in [MPS/MRP](#): it may be a released or active production or purchase order or a suggested or confirmed [schedule](#).

Scheduling

The process of calculating and suggesting due dates, quantities and action dates for the [supply](#) of an item to meet required [demand](#) quantities and dates

Seasonal Profile

This is a method used to spread forecasts using indices for each forecast period and entering a total figure to spread. It can be used to speedily determine forecast values which display seasonal fluctuations.

Serial Number Control

A form of [lot control](#), which maintains single, uniquely identified (serialised) units

Set Up

This is the activity of preparing machines or processes for production. [Set up time](#) forms part of the [lead time](#) of an [operation](#).

Set Up Time

This is the duration of the [set up](#) for a [work station](#). It is expressed as a [labour time](#).

Shelf Life

The life of an item expressed in its [Shelf Life Unit](#)

Shelf Life Unit

This indicates the unit in which an item's [shelf life](#) is measured.

It may be:

- Days
- Weeks
- Months
- Years
- Unlimited

Shift Length

The duration of an individual working shift for a [work station](#)

Shift Profiles

These describe the pattern of shifts in a day. Shift profiles use effectivity dates to reflect planned changes in patterns. A default shift profile may be assigned to a work station, or a shift profile assigned to each working day within a week at a work station. The shift profile defines the number of productive hours [available](#) on a working day.

Shipper Number

A number assigned to each shipment of items to or from a subcontractor if [Shipper Tracking](#) is in use

Shipper Tracking

A method of tracking materials or [WIP inventory](#) to or from subcontractors

Shrinkage (Material)

The planning factor applied to an [input](#) on a [route](#) to reflect expected loss

Shrinkage (Operation)

This is the planning factor applied to an [operation](#) to reflect expected losses. [Scheduling](#) uses the factor to inflate the standard times to make the required lot size.

Shrinkage Cost

This is the amount of item [unit cost](#) attributable to [operational](#) or material shrinkage in the production process. It is held by [Cost](#) Element and can optionally be consolidated into the item [cost elements](#). A shrinkage element can be configured to display the total shrinkage cost.

Simulated Cost

A function which projects product [costs](#) by applying variables to the cost structure to ascertain likely future costs, or by changing [inputs](#) to ascertain the cost impact of the changes

Single Level Enquiry

A one level explosion of a [bill of material](#) and [route](#) and which [costs](#) the [inputs](#) and [operation](#) processes required to make the parent item

Smoothing Policy

A planning policy which smoothes sale forecast [demand](#) to provide a level [production schedule](#)

Specification Ref

This refers to the way in which an item is specified.

Standard Capacity

The daily [capacity](#) in hours of a [work station](#) when operating at its normal rate, and normal shift patterns

Standard Capacity Factor

This may be applied to a shift profile to determine the standard number of hours available at a [work station](#). In situations where the work station comprises multiple machines or personnel, the factor will represent the number of machines and people at that work station. For example, for a shift profile of 10 hours at a work station where 2 machines operate, a [capacity](#) factor of 2 would be entered, to indicate a [standard capacity](#) of 20 hours.

Standard Costs

This is a [costing method](#) available in Production and Inventory. Standard costs are calculated for items based on standard [cost](#) rates and [operation](#) times and the standard costs of [inputs](#). They form the yardstick for performance measurement in a given period.

Standard Efficiency

This is the percentage of the [standard capacity](#) of a [work station](#) which you expect to achieve under normal [operational](#) circumstances. This percentage may be used in [capacity planning](#) enquiries and reports.

Standard Lot Size

Standard batch size in terms of which [input](#) quantities and [operation](#) times are expressed in a [route/structure](#)

Standard Potency

This is the standard strength of an item expressed as a percentage. It applies to lot-controlled items only.

Standard Production Orders

Production orders which are based on a standard [route](#) to obtain [input](#) requirements and [operation](#) details

Start Date

The scheduled release date of a production or purchase order or [schedule](#)

Start Date (Planning)

This is the first date considered by [MPS](#) and [MRP Demand](#) and [Supply](#) prior to this date is ignored. It is the Current Date less Overdue days set for the planning run.

Stock Forecast

A forecast used in [MPS](#) and [MRP](#) to plan variable levels of inventory availability to maintain desired customer service levels over and above standard [safety stock](#).

Stock Monitor

This is an Inventory Management function, which maintains the integrity of lot-controlled stock availability. It determines whether a lot is available or has passed its [Last Available Date](#) or [Expiry Date](#). All lots are frozen when the Last Available Date is passed.

Stock Run-out Policy

This controls the planning of requirements of an item based on its stock [balance](#), rather than effective dates.

The available policies are:

- Use up stock and do not re-plan
- Use up stock and then use a nominated replacement item or items

Subcontract Operation

This is work on the production of an item that is carried out by another manufacturer. It entails sending materials or [WIP](#), which are worked on by the subcontractor before being returned for further [operations](#), or quality inspection or receipt into stock.

Subcontractor Stockroom

This is a [logical stockroom](#), which holds all subcontractor material [balances](#). Subcontractor [WIP inventory](#) balances are held as balances at [operations](#) in the associated [work station WIP location](#).

Substitute

This is an item which has been designated as an allowable replacement for another item. It may be issued in whole or part to a production order, if there is insufficient stock of the primary item.

Substitution Policy

This is defined on a [route/structure input](#) item definition, indicating whether it is permissible to use a [substitute](#) item if there is a stock shortage of the primary item.

Suggested Production Order

An [MPS](#) or [MRP](#) recommendation to create a production order to satisfy a shortage identified by the planning process

Suggested Purchase

An [MPS](#) or [MRP](#) recommendation to create a purchase order to satisfy a shortage identified by the planning process

Supply

The planned or [scheduled receipt](#) of item quantity from a purchase order or production order or a [production schedule](#) item

Target Yield

Desired yield of a [route](#)

This Level

The final level of manufacture for an item with a multi level [route/structure](#), as opposed to lower levels of manufacture such as sub-assemblies

Time Basis Code

This is the code indicating how [operation](#) times are expressed on a [route](#).

Codes are:

- Time per lot
- Time each
- Quantity per hour
- Fixed time
- Time per 1000
- Time per 100
- Time per fixed batch

Time Booking Policy

This parameter is set on the [Organisational Model](#) to control the time [booking](#) format in Production reporting. It may be in decimal hours or hours and minutes. This policy is set only if the [Time Reporting Policy](#) is set to elapsed time.

Time Fence

This is the period between the current date and the time fence date. During this time fence, the [schedule](#) is fixed and no recommendations are made by [MPS](#) or [MRP](#) to change existing production or suggest new production.

Time Fence Days (Planning)

The number of days that are added to the Current Date to calculate the [Time Fence](#) Date

Time Fence Policy

Parameter set at item level indicating whether shortages occurring within the [time fence](#) should be ignored, or satisfied on the Time Fence Date

Time Reporting Policy

This parameter is set on the [organisational model](#) to control the format in which operator and [work station](#) times at an [operation](#) are entered. It may be set for entry as elapsed time or as work start time and stop time.

Time Units

These are the units in which [operation](#) times are expressed. They are defined in the [company profile](#) and can be in hours or minutes.

Total Shelf Life

This is the life of an item lot. The [shelf life](#) is added to the [Creation Date](#) to calculate the [Expiry Date](#).

Transaction Manager

This is the function that processes production and [WIP inventory](#) transactions, generates movement records and updates [balances](#). It runs in its own subsystem and may be started and stopped. It must be running in order to keep balances and transaction details up to date during production [bookings](#).

Transaction Number

Each production [booking](#) entered on the system is allocated a system transaction number which may be accessed and displayed for subsequent reference in enquiries and reports.

Transaction Type

These are System21 transaction codes, which represent a particular [balance](#) update or movement generation. The transaction type calls a program, which ultimately updates the database.

Trial Kit

A method of simulating [input](#) allocation to a production order or [route](#) to assess availability to meet the requirements (also known as Material Availability Enquiry)

Trigger

This is the mechanism used to drive [Net Change MRP](#). Item Triggers are created when transactions are recorded for unplanned events.

Triggers may be generated through:

- Maintenance changes
- Sales, purchase or production orders
- Set up changes
- Stock issues and receipts
- MPS/MRP schedule amendments

Trigger Tolerance

This is the percentage (above or below) of [safety stock](#) which, if breached by the projected [available stock](#), will cause a [net change trigger](#) to be written for the item.

Unit Cost

The amortised [cost](#) of a single unit of an item

Unplanned Issue

Issue of [inputs](#) to a production order, which has not been previously allocated

Unplanned Receipt

Receipt into inventory of an item or items not expected at the [booking operation](#), i.e., not standard on the [route](#), or order.

Usage

The quantity of an item issued from a stockroom in a given period

Usage Profile

A user defined profile which specifies the pattern of periods to be included in the calculation of [average usage](#)

Utilisation

The extent to which the [capacity](#) of a [work station](#) is expended by actual work performed

Value/Usage

This is the value/usage setting for an item in Inventory. It positions the item in a matrix of value/usage. It is a selection criterion for selective [MRP](#).

Variance

A difference between the standard [cost](#) or volume of a process and the actual recorded cost or volume

Waste Product

An [output](#) from a [process route](#) which does not have any intrinsic worth or saleable value and which may incur a [cost](#) in its disposal or shortage

WIP

Acronym for Work-in-progress (also known as Work-in-process)

WIP Inventory

[Work-in-progress](#) inventory, transparent to Inventory Management, but accessible through enquiries in Production WIP Inventory Control

WIP Location

A WIP location is a stockroom that has been logically associated with one or more [work stations](#) as the stockroom to hold [WIP inventory balances](#) produced at [count point operations](#).

Work Centre

This is a collection of [work stations](#) that have been grouped together for [capacity requirements](#) analysis purposes. Work centres are not used in planning or work station [scheduling](#).

Work Station

The standard production unit or facility for which [capacity requirements](#) are measured

Work Station Schedule

A daily work plan for a [work station](#), containing item and order quantities and duration of [set up](#) and operating hours

Work-in-progress

This is the value of work currently underway in the factory in terms of the material issued, and the [operations](#) performed. For a given order or [schedule](#), it is calculated as the value of material and work [input](#) less the value of receipts made into stock. Work-in-progress (WIP) can be valued at standard or [current cost](#).

Yield Item

This is an item that is sensitive to yield either as an [input](#) or an [output](#). Yield is the ratio of total quantity of outputs compared to the total quantity of inputs.