



Infor LN Manufacturing User Guide for Assembly Control

Copyright © 2024 Infor

Important Notices

The material contained in this publication (including any supplementary information) constitutes and contains confidential and proprietary information of Infor.

By gaining access to the attached, you acknowledge and agree that the material (including any modification, translation or adaptation of the material) and all copyright, trade secrets and all other right, title and interest therein, are the sole property of Infor and that you shall not gain right, title or interest in the material (including any modification, translation or adaptation of the material) by virtue of your review thereof other than the non-exclusive right to use the material solely in connection with and the furtherance of your license and use of software made available to your company from Infor pursuant to a separate agreement, the terms of which separate agreement shall govern your use of this material and all supplemental related materials ("Purpose").

In addition, by accessing the enclosed material, you acknowledge and agree that you are required to maintain such material in strict confidence and that your use of such material is limited to the Purpose described above. Although Infor has taken due care to ensure that the material included in this publication is accurate and complete, Infor cannot warrant that the information contained in this publication is complete, does not contain typographical or other errors, or will meet your specific requirements. As such, Infor does not assume and hereby disclaims all liability, consequential or otherwise, for any loss or damage to any person or entity which is caused by or relates to errors or omissions in this publication (including any supplementary information), whether such errors or omissions result from negligence, accident or any other cause.

Without limitation, U.S. export control laws and other applicable export and import laws govern your use of this material and you will neither export or re-export, directly or indirectly, this material nor any related materials or supplemental information in violation of such laws, or use such materials for any purpose prohibited by such laws.

Trademark Acknowledgements

The word and design marks set forth herein are trademarks and/or registered trademarks of Infor and/or related affiliates and subsidiaries. All rights reserved. All other company, product, trade or service names referenced may be registered trademarks or trademarks of their respective owners.

Publication Information

Document code	tiascug (U9603)
Release	10.6 (10.6)
Publication date	August 5, 2024

Table of Contents

About this document

Chapter 1 Introduction	11
Introduction.....	11
Benefits of the Assembly Control module.....	11
Assembly Control overview.....	11
Chapter 2 Assembly Lines	15
Assembly Lines.....	15
Linking a supply line to multiple parent lines (Divergent assembly line structure).....	16
Linking a supply line to multiple parent lines.....	17
Line Segment.....	18
Line Station.....	19
Linking a supply line to multiple supply lines.....	20
Divergent structure and Assembly Orders - Unique link.....	21
Assembly line selection— Configuration Dependent parameter.....	24
Assembly line modeling.....	26
Product structure and supply line.....	27
Synchronizing a supply line with mutiple parent lines.....	28
Transportation time for linked assembly lines.....	29
Chapter 3 Parameters	33
Assembly Line Structure Parameters.....	33
Implemented software components.....	33
Assembly control parameters.....	33
Bucket definition.....	34
Segment schedules.....	35
Selling multiples of product variants for assembly.....	35
Chapter 4 Process Engineering	37
Process Engineering.....	37

Buffers and line stations.....	37
Assembly Lines.....	37
Line Segments.....	37
Linking line segments to assembly lines.....	38
Linking stations to line segments.....	38
Defining Assembly Line Assignments.....	39
Process characteristics.....	39
Linking the assignment to line stations.....	40
Validating Assembly Lines.....	40
Actualizing Assembly Lines.....	41
Creating Operations.....	41
Linking operations to line stations.....	42
Chapter 5 Product Engineering.....	43
Product Engineering Introduction.....	43
Flattened BOM.....	44
Engineering data management summary.....	45
Engineering items.....	45
Engineering bills of material.....	45
Changing the EBOM.....	46
Unit effectivity in EDM.....	46
Item Data.....	46
Linking product features to generic items.....	47
Mask by Item/Item Group.....	48
Creating Generic BOMs.....	49
Creating sales price lists for generic items.....	49
Assembly BOMs and operations.....	49
Assembly Line Material Supply.....	50
Linking generic items to assembly lines.....	51
Assembled items through warehousing after roll-off from main line.....	51
Delivering to customers directly from the assembly line.....	55

Chapter 6 Costing Data	57
Calculating Standard Cost and Actualizing Assembly Lines.....	57
Chapter 7 Sequencing Engine Data Setup	59
Line sequencing and rule types in Assembly Control.....	59
SEQUENCE RULES.....	59
The (re)mixing process in Assembly Control.....	60
Mix rules.....	60
Placement rules.....	61
Priority.....	65
THE SEQUENCING PROCESS.....	65
RESCHEDULING.....	66
LINE SEQUENCE STATUS.....	66
Defining Option Combinations.....	69
Define option combination list.....	70
Create line rule.....	71
Link line rule to line segment.....	71
Defining Sequence Parameters for Line Segments.....	71
Chapter 8 Assembly Control Business Flow	75
Creating Sales Order Lines.....	75
Sales order entry.....	75
Product variants in Sales.....	76
Reviewing Product Variants.....	78
Calculating assembly part requirements.....	79
Assembly orders.....	80
Assembly order statuses.....	80
Assembly order progress.....	81
Serialized items in assembly control.....	81
Line station variants and line station orders.....	82
Purpose.....	82
Sessions.....	82

Order-specific LSVs.....	82
Line station order.....	83
Sequencing Assembly Orders.....	84
Serialized items in Manufacturing.....	85
To set up serialized items.....	85
As-built structure.....	85
Serial numbers.....	86
Masks for serialized items.....	86
To use serial numbers during the production order process.....	87
Working with serialized items in Manufacturing.....	88
Assigning serial numbers.....	89
Building Assembly Part Allocations.....	93
Refreshing and Freezing Assembly Orders.....	95
Starting and Completing Line Station Orders.....	97
Receiving assembled items in inventory.....	98
Checking inventory of assembled items.....	98
WIP transfers in the Assembly Control (ASC) module.....	99
Single company.....	99
Multicompany.....	100
Executing WIP Transfer.....	101
Backflushing Assembly Parts and Hours.....	101
Closing assembly orders.....	102
Closing assembly lines.....	103
Post-assembly operations.....	105
Procedure.....	106
Processing Sales Order Line.....	106
Chapter 9 Unit Effectivity.....	107
Unit effectivity in EDM.....	107
Finalizing Engineering Data.....	107
To set up unit effectivity.....	108
How to continue.....	108

Chapter 10 Procuring Configured Items.....	109
Procuring configured items in Assembly Control - Master Data Setup.....	109
Procuring configured items in Assembly Control - BOM setup.....	110
Generic BOM - PCF.....	110
Product Variant Structure.....	111
Product variants - Purchased configurable items.....	112
Compare variants.....	112
Variant numbers and Option list IDs.....	113
Product variant purchase price structure.....	113
Chapter 11 Concepts.....	115
Assembly Control.....	115
Performance aspects.....	116
Delete Assembly Orders.....	116
Assembly order deletion-Important Points.....	116
Assembly items.....	117
Restrictions.....	117
Item types Generic, Manufactured and Product.....	117
Assembly items and FAS items.....	118
Assembly Order Costing.....	118
Differences between costing in Job Shop Control and Assembly Control.....	119
Procuring configured items in Assembly Control - BOM setup.....	120
Generic BOM - PCF.....	120
Product Variant Structure.....	122
Product Configuration (PCF).....	122
Performance aspects.....	123
PCF procedures.....	123
Parameter sessions.....	123
How to define a product model.....	125
Process Trigger Definition (tiasl8100m000).....	127
Defining a mask.....	129

Defining and using masks.....	129
Defining a translation table.....	130
Product variants in Warehousing.....	130
Supported by LN.....	131
Prerequisites.....	132
Allocation Buffers.....	132
Generate Outbound Advice.....	133
Adjustment and Cycle Counting Order Lines.....	133
Assembly backflushing.....	134
Floor stock.....	134
Backflushing mode.....	134
Assembly parts.....	134
Man hours and machine hours.....	134
Appendix A Glossary.....	137

Index

About this document

This document provides an overview of the options to control the processes on the shop floor that produce FAS items. The setup process, options, steps and functions of managing the manufacture of these items are described.

Intended audience

This document is intended for the following categories of users:

- Users who set up Assembly Control data and processes.
- Users who perform and monitor the Assembly Control processes.

The intended audience can include implementation consultants, product architects, support specialists, and so on.

Assumed knowledge

Knowledge of the following LN topics is required:

- Manufacturing
- Common
- Shop Floor Control
- Enterprise Planning
- Order Management
- Warehousing

Document summary

This document provides a brief introduction to Assembly Control functionality. It also contains assembly control concepts that explain the master data setup, and leads you through an end-to-end business flow.

Comments?

We continually review and improve our documentation. Any remarks/requests for information concerning this document or topic are appreciated. Please e-mail your comments to documentation@infor.com.

In your e-mail, refer to the document number and title. More specific information will enable us to process feedback efficiently.

Contacting Infor

If you have questions about Infor products, go to Infor Concierge at <https://concierge.infor.com/> and create a support incident.

If we update this document after the product release, we will post the new version on the Infor Support Portal. To access documentation, select **Search Browse Documentation**. We recommend that you check this portal periodically for updated documentation.

If you have comments about Infor documentation, contact documentation@infor.com.

Introduction

Many products are manufactured in assembly-line-oriented flow production environments. These environments are characterized by high production volumes and the complexity of producing many different configurations.

Companies in these environments, for example, car manufacturers, require a manufacturing execution system which enables them to configure, schedule, carry out, and control many orders per day, without much system overhead.

To support these environments, you can use the Assembly Control (ASC) module. This module provides functionality for the planning, scheduling, and carrying out of assembly orders on assembly lines.

Benefits of the Assembly Control module

Assembly Control overview

Use the Assembly Control (ASC) module to schedule and control assembly orders. Assembly control can be used in high-volume and low-volume environments. You can select a line station or order based processing at the time of implementation, based on your requirements.

System performance is enhanced, and the data storage capacity is reduced through the use of the following:

- Line-station based transaction handling. Transactions are carried out by period.
- Line-station variants. Orders are stored by common variants rather than individually.

The functionality of Assembly Control can be roughly divided into the following sections:

- **Sequencing**
The assembly orders can be remixed and scheduled by Assembly Control.

- **Dispatching**
Material requirements are dispatched to the job shop or to a supplier, and work instructions can be printed. Many of these processes are run by process triggers.
- **Monitoring**
Events are reported to LN in order to continue the assembly process using real-time activities.
- **Costing**
Most of the financial calculations are carried out outside the scope of Assembly Control. Cost components can be defined on either a detailed or aggregated level, or a combination of the two.

The Assembly Control (ASC) module can support the following concepts:

- **Optimization**
The optimization of the sequence on which the orders are assembled.
- **Different cycle times**
Different shifts for the assembly lines with each operating at different line speeds called cycle times. For more information, refer to [cycle time](#).
- **Partial freeze**
You can change the specifics of the ordered item, even when assembly of that item has already started. For more information, refer to [freeze](#).
- **Multicompany**
Enterprises today have [multicompany](#) assembly structure, often across the nations. The Assembly Control solution supports assembly processes in multicompany environments.
- **Using the process-triggered workflow to reduce manual inputs**
The assembly the products must proceed in the optimal fashion, aided by an information system. In a flow-oriented assembly environment, progresses are highly predictable. The Assembly Control module requires minimal user input. Predictable tasks are automated using *Process Triggering*, which reduces non-value added tasks and increases efficiency levels.
- **Bar code techniques**
Printing and reading information using bar codes, reducing manual inputs, and increasing efficiency and accuracy.
- **Just-in-Time techniques**
The demand and supply of the material, that is [JIT item](#), to the assembly line is synchronised to the last minute. LN Assembly Control supports the JIT techniques by a wide range of supply methods and supply optimization methods.
- **Collaboration with external suppliers**
LN Assembly Control supports the delivery of goods by an external supplier; directly to assembly Line, at the correct time, to the correct place, in the correct order ([supply in line sequence](#)), using purchase schedules and EDI.)
- **Efficient costing techniques**
Line-station-based costing, Hours and Materials Back Flushing per line station or segment of the line instead of per order, which reduces system overhead and improves performance. For more information, refer to *Assembly Order Costing (p. 118)*.

- **High volumes**
Assembly environments often deal with high volumes of complex configurations and related execution orders. The LN *Assembly Control* (p. 115) solution supports high-volume assembly environments from a functional perspective and a performance perspective.
- **After Sales Service**
Unique serial numbers can be generated for every end item and assembly part, for example, the VIN number. Existing standards and legal formats can be supported. *As Built* information is collected when the product is assembled to support the process of lifecycle management.

Assembly Lines

Assembly lines are a set of consecutive line stations in which Final Assembly Schedules (FAS) items are manufactured. Assembly lines consist of a series of line segments. Segments consist of a buffer and one or more line stations, until the next buffer. The items are manufactured by passing the items from line station to line station and by carrying out operations at each line station.

Assembly line

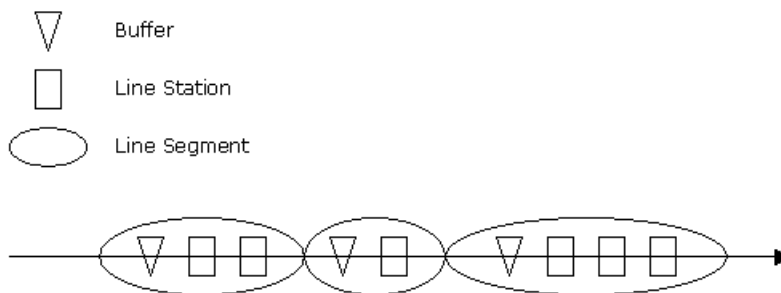

On each line, items can be assembled. But, a line from which an item rolls off can be considered a roll-off line. The line contains different segments, which represent a *grouping* of different stations/operations on an assembly line. The advantage of grouping line stations and operations is that you can create optimal sequences per line segment by using the sequencing engine. For example, each segment can have specific features/options you can use to create an optimal sequence.

The line structure can also contain a supplying assembly line on which subassemblies are assembled or spare parts are manufactured. This assembly line supplies subassemblies and spare parts to the main assembly line. A supply line can also produce independent products for selling. The main assembly line and the supplying assembly line can be located in the same logistical company or different logistical companies. The financial company is equal to the logistical company.

The basic assembly control concepts are explained below.

- **Line segment:** A set of consecutive assembly-line work centers on an assembly line between two buffers. The first buffer is the beginning of the segment, the next buffer is the first part of the next segment.
- **Station type:** A station can be one of the following types:
 - **Line station:** A work center that is part of an assembly line. A line station is used in the production of FAS items. A line station can have multiple positions, which enable more than one item to be present in one line station.
 - **Buffer:** An assembly line workstation where no operations are carried out, and where orders are waiting to enter the following work station. You can use buffers to change the sequence of products from one line segment to another. Following are the types of buffers:
 - **Buffer (FIFO).**
 - **Buffer (random access).**Buffer is used to change the sequence of products from one line segment to another.

Note

- You define the station type as line station or buffer in the Work Centers (tirou0101m000) session.
- The buffer is used for sequencing purposes.
- The line segment must always starts with a buffer.

Linking a supply line to multiple parent lines (Divergent assembly line structure)

In the current business scenario, the Original Equipment Manufacturers (OEMs) are increasingly beginning to operate on a global scale. This means that a end product can be assembled at one geographical location and its components can be assembled at one or multiple geographical locations. After the components are assembled, they are transferred to different locations where the final assembling of the end product takes place. To model this requirement, you can set up a divergent assembly line structure in LN. In divergent assembly line structures, you can link one assembly line to multiple assembly lines.

Example

In the divergent assembly line structure, as modeled in the figure below, one supply line is linked to multiple main assembly lines. In our example, the supply line E is linked to main lines A and B. The supply line F is linked to main lines B and C. The supply line F is located in a different geographical area with respect to main line B.

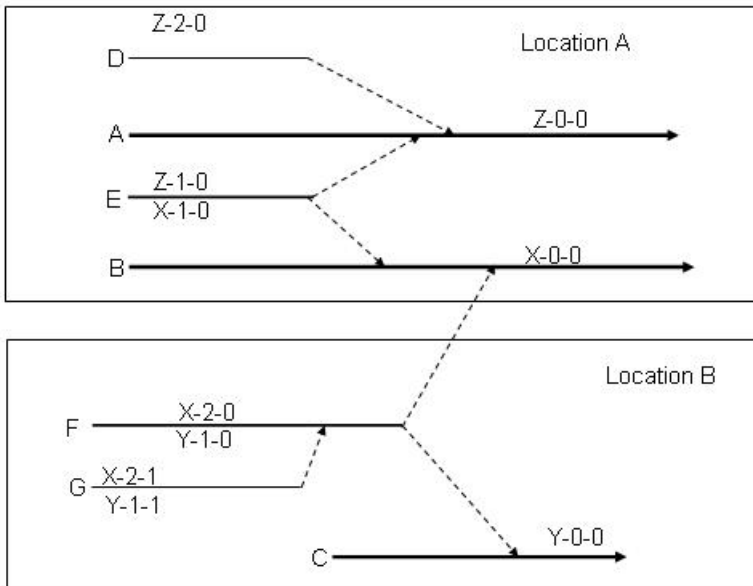

Note

The lines can physically reside in different geographical locations, but are logically linked to one assembly line structure.

Important!

You can model divergent assembly lines for both multicompany as well as single company scenarios. In a multicompany assembly scenario, you can define a divergent assembly line structure in the master company, and replicate the structure to the other companies.

Linking a supply line to multiple parent lines

You must link a supply line to parent lines at the following two levels:

1. Line segment
2. Line station

Example

The following example shows a divergent supply line structure in which a supply line is linked to two different parent lines.

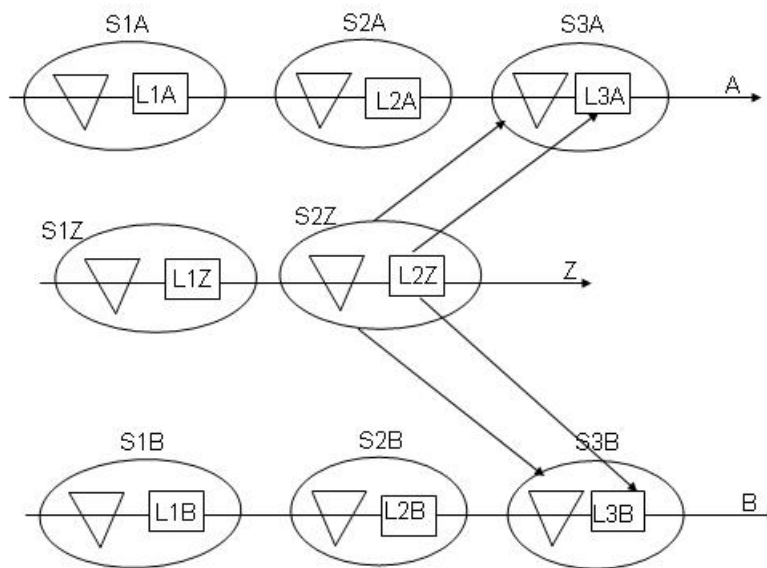

Supply Line z linked to main lines A and B

Legend

A	First main parent line (<u>main assembly line</u>)
B	Second main parent line
Z	<u>Supply line</u> for main lines A and B
S1A to S3A	Consecutive line segments on main line A
L1A to L3A	Consecutive line stations on main line A
S1Z to S2Z	Consecutive <u>line segments</u> on supply line Z
L1Z to L2Z	Consecutive <u>line stations</u> on supply line Z
S1B to S3B	Consecutive line segments on main line B
L1B to L3B	Consecutive line stations on main line B
Inverted Traingle	Buffer

Line Segment

On the line segment level, you can link the last line segment of the supply line to line segments located on different parent lines.

In the above example, the last line segment (S2Z) on the supplying line Z can be linked to both line segments S3A on main line A and S3B on the main assembly line B.

Line Segment	Next Line segment
Segment S1Z	Segment S2Z
Segment S2Z	Segment S3A
Segment S2Z	Segment S3B

Note

- You cannot link a line segment to more than one line segments of the same assembly line. In the above example, you cannot link the segment S2Z on supply line Z to both the segment S2A and S3A on main line A.
- Only the last line segment of the supplying line can be linked to multiple next segments which are on different lines. In the above example, only segment S2Z of the supply line Z can be linked to segment S3A on main line A and S3B on main line B.

Line Station

On the line station level, you can link the last station of the supply line to line stations located on different parent lines.

In the example above, the last line station L2Z of supply line Z can be linked to both line station L3A on main line A and station L3B on main line B.

Station	Next Station
Buffer of Segment S2Z	Station L2Z
Station L2Z	Station L3A on main line A
Station L2Z	Station L3B on main line B

Note

- You cannot link a line station to more than one line stations of the same assembly line. In the example above, you cannot link the line station L2Z on supply line Z to both the station L2A and L3A on main line A.
- Only the last line station of the supplying line can be linked to multiple next line stations. In the example above, only line station L2Z of supplying line Z can be linked to line station L3A on main line A and L3B on main line B.

Linking a supply line to multiple supply lines

You can model an assembly line network with the following types of supply line structures:

- **Convergent:** You can link one assembly line (for example, serving as a supply line) to only one assembly line that can be a supply line or a main line.
- **Divergent:** You can link one assembly line to different assembly lines. Example one supplying line linked to different main assembly lines.

Note

You cannot model an assembly line structure with parallel assembly operations.

During configuration of an item, when a user selected a product model in which the routing of subassemblies is determined based on the configuration of the assembled main item (the assembled end item can use for example, either part X1 or part X2, which are supplied by two different assembly lines), the definition of an assembly line network model that has assembly lines modeled in parallel is allowed. Then, after configuration, when the routing is determined, a check is performed to determine that the selected routing does not contain assembly lines which are modeled in parallel. If assembly lines that are modeled in parallel are found, the system indicates that the specific assembly structure cannot be generated. As a result, the specific configuration cannot be built.

The figure above represents an assembly line structure in which two lines are modelled in parallel. Based on the selected configuration of the assembled main item Z (whether Z contains X1 or X2), either supply line C1 or C2 is included in the assembly line network model. You cannot select more than one line when lines are modelled in parallel.

- If option X1 is selected during the configuration of the main item Z, the assembly line C2 is excluded. The routing contains main supply line C3 that supplies item Y to supply line C1. The supply line C1 uses item Y to manufacture the subassembly X1 which is supplied to main line M. M is the roll-off line for end item Z. This routing does not contain parallel assembly lines.
- If option X2 is selected during configuration of the main item Z, the assembly line C1 is excluded. The routing contains main supply line C3 that supplies item Y to supply line C2. The supply line C2 uses item Y to manufacture the subassembly X2 which is supplied to main line M. The M is the roll-off line for main item Z. This routing does not contain parallel assembly lines.

Important!

A supply line can be included or excluded by the system only when the **Configuration Dependent** check box is selected for a supply line in the Assembly Lines (tiasl1530m000) session. For more information, refer to *Assembly line selection— **Configuration Dependent** parameter (p. 24)*

Example

In this example, the assembled end item Z must contain either sub-assembly X1 or X2 supplied by different assembly lines.

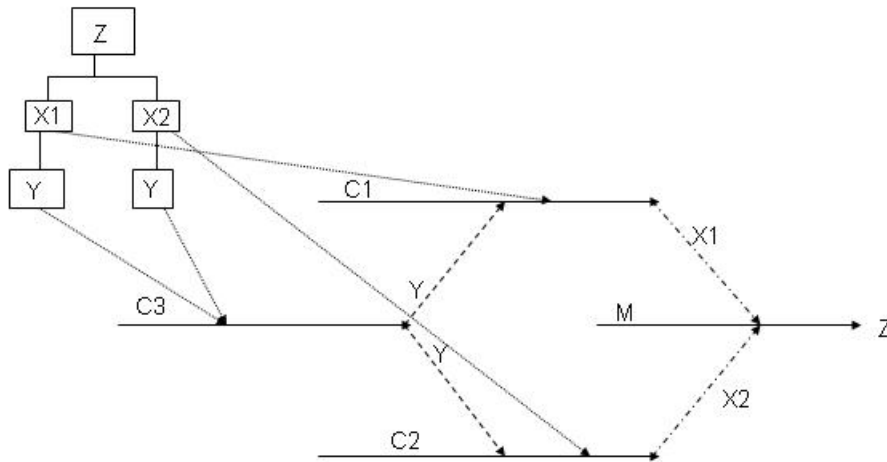

Parallel assembly operations- Permitted only during item configuration

Legend

- Z Main configured end item(main item)
- X1 or X2 subassemblies).
- Y Part Y is required to manufacture X1 or X2
- C3 Main supply line, supplying Y to C1 and C2
- C1 Supply line for item X1 which is delivered to main line M
- C2 Supply line for item X2 which is delivered to main line M
- M Main assembly line which manufactures configured end item Z

Divergent structure and Assembly Orders - Unique link

Divergent supplying line structure allows you to link a supply line to multiple parent lines. However, the assembly orders on the supply line must still refer to a single assembly order on a parent line, at any given point of time. The supply line can supply an item to different parent lines but a unique reference link is maintained between the assembly orders of the supply line and the assembly orders of the parent lines.

Note

A single assembly order on a supply line cannot have reference to multiple assembly orders on different parent lines.

Example

Please refer to the figure for assembly order numbers.

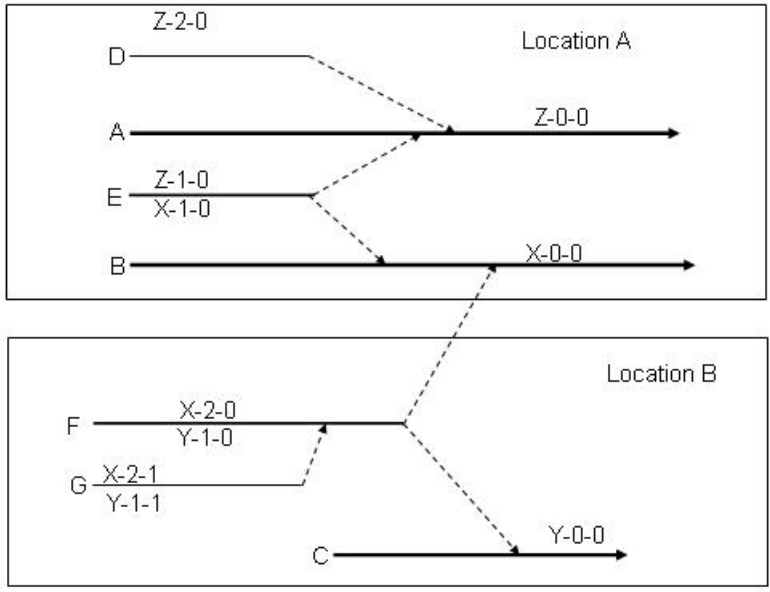

Assembly Line	Assembly Order	Parent Assembly Order
A	Z-0-0	<None>
B		
C		
D	Z-2-0	Z-0-0
E	Z-1-0	Z-0-0
F		
G		

Assembly Line	Assembly Order	Parent Assembly Order
A		
B	X-0-0	<None>
C		
D		
E	X-1-0	X-0-0
F	X-2-0	X-0-0
G	X-2-1	X-2-0

Assembly Line	Assembly Order	Parent Assembly Order
A		
B		

C	Y-0-0	<None>
D		
E		
F	Y-1-0	Y-0-0
G	Y-1-1	Y-1-0

Assembly line selection— Configuration Dependent parameter

You can use a subset of the supply lines for the assembly of the main item or end item. Effectively, it is possible to exclude the supplying lines that are not used, from the assembly line network structure. It is possible to route the assembly of a configured end item through a subset of the assembly lines that are part of a bigger generic assembly line structure. The routing is based on the product structure of the configured main item or the end item.

In a scenario wherein a configured end item can use one of the two possible subassemblies supplied by different supply lines, an appropriate route or a supply line is selected based on the product structure of the configured main item or end item.

Note

Operations and material linked to the selected subset of assembly lines are included in the assembly order data. Operations and material that are linked to excluded assembly lines are not included in the assembly order data.

Example

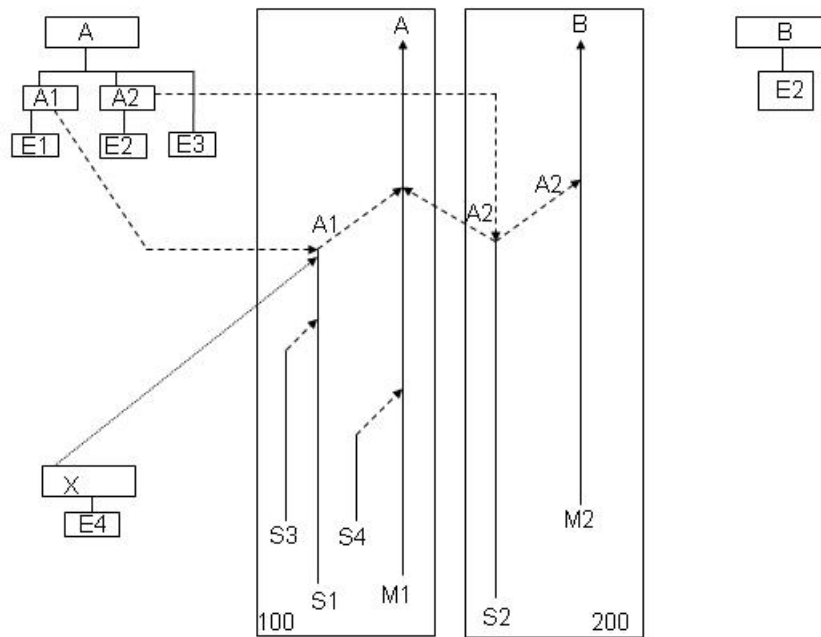

Legend

- A** Item A which can contain either item A1 or item A2, produced on M1
- A1** Item A1 manufactured by line S1
- A2** Item A2 manufactured by line S2
- E1** Engineering module number one
- E2** Engineering module number two
- E3** Engineering module number three
- M1** Main line number one
- S4** Supply line for main line M1
- S1** Supply line that supplies optional item A1 to the main line M1
- S3** Supply line for S1
- X** Item X is a spare part, also manufactured by line S1
- E4** Engineering module number four pertaining to item X
- 100** Company number 100
- S2** Supply line that supplies optional item A2 to the main line M1 and M2
- M2** Main line number two
- 200** Company number 200
- B** Item B which contains A2, produced on M2

In this example, based on the generic product structure, when you configure item A, either item A1 or item A2 can become part of the product structure for item A. It is not possible to include both, item A1

and item A2, within a product variant for item A. This implies that either supply line S1 (with all its sub-level supply lines) or supply line S2 (with all its sub-level supply lines) can become part of the assembly order data for the configured item A.

For the assembly of item B or item X, no supply line selection is required as their generic product structure indicates a fixed assembly line model. Therefore, independent of the configuration of item B or item X, all assembly lines of the assembly structure are included and utilized for production of item B or item X.

Note

- Item B is not part of the generic product structure of item A. Similarly, item A is not part of the generic product structure of item B.
- Item X does not belong to either the generic product structure of item A or item B. Similarly, item A or item B does not belong to the generic product structure of item X.

Assembly line modeling

The appropriate supply line is selected by the system, based on the product structure of the configured end item. In the example, the configured end item A can contain either item A1 or item A2 which implies that either supply line S1 or S2 can be selected.

Important!

A supply line can be selected only if the **Configuration Dependent** check box is selected in the Assembly Lines (tiasl1530m000) session.

Note

When an assembly line is the roll-off line in an assembly model, the **Configuration Dependent** parameter is not considered, because a roll-off line can never be excluded from the assembly order data.

Important!

If you modify the **Configuration Dependent** parameter for an assembly line which is **Actualized**, the line status is not reset to **Modified** and the existing assembly orders are not affected. The parameter change impacts the generation of assembly line structure for modified or newly created product variants or product structures.

The following are the settings of the **Configuration Dependent** parameter with respect to the item A supply lines in the example:

Assembly line	Configuration Dependent setting
M1	No (roll-off line for configurable item A)
M2	No (roll-off line for configurable item B)
S1	Yes (for item A, S1 is optional line) (for item X its a roll-off line - cannot be excluded)
S2	Yes (for item A, S2 is optional line)(for item B its a fixed line - cannot be excluded)
S3	No (dependent on S1. If S1 is included or excluded, S3 is automatically included or excluded respectively)
S4	No (fixed line for configurable item A)

Product structure and supply line

As part of product structure definition, the exclusion of assembly line is not only based on the **Configuration Dependent** parameter but also on the following factors:

- A relationship must be defined between the item assembled on the supply line and the supply line.
- The item assembled on the supply line must be defined in the generic product structure for the assembled end item.

Note

You can use the Configurable Item - Assembly Line (tiapl2500m000) session to define the relationship between the item assembled on the supply line and the supply line.

For the generic product structure of configurable item A in our example, the following relationships must be defined:

Configurable item	Assembly line
Item A	M1
Item A1	S1
Item A2	S2

In the example, although the supply line selection does not apply to configurable item B and X, the following relations must be defined in order to correctly determine assembly order data for these items:

Configurable item	Assembly line
Item B	M2
Item X	S1

Synchronizing a supply line with mutiple parent lines

For a divergent supply line structure, multiple parent lines can synchronize with the same supply line. In such a scenario, for each assembly order, the supply line must be synchronized with the parent line only after the system determines that the supply line is part of the assembly line model required to assemble the configured end item. The system determines the inclusion of the supply line based on the **Configuration Dependent** parameter

After the assembly order sequence for a parent line is generated, the sequence of the parent line segment must be synchronized with the sequence of the linked last segment of the supply line. If the parent line segment is linked to multiple supply lines, then the sequence of the parent line segment must be synchronized with the sequence of last segment of every supply line that supplies to that parent line segment.

A parent line synchronizes with the supply line to fix the sequence of the assembly orders on the supply line. As a result of this synchronization, the end date of the line station order (LSO) of the last line station of the last line segment of the supply line connected to the parent line, is set to the start date of the LSO on the linked line station of the parent line.

Therefore, in a scenario where multiple parent lines synchronize with a single supply line, the *First come - First serve* concept is used to determine a *fixed* position for assembly orders on the supply line. This fixed sequence cannot be changed even if the supply line is re-sequenced at a later stage, for another parent line.

When another parent line is sequenced and synchronized with the same supply line, the previously fixed positions of the assembly orders are not changed. The synchronization process tries to fix the assembly orders in a position as close as possible to the start date of the LSO, on the linked line station of the parent line.

The search for a position is limited to 30 days. If the assembly order cannot be fixed in a position which is closest to the requirement date of the LSO of the line station, the system backdates the search for an available position to fix the assembly order until 30 days before the start date. If the order cannot be fixed within the 30 days, the assembly order is fixed in an available position, at a date in the future, surpassing the requirement date. A message is displayed stating that the synchronization is not completed successfully.

When a parent line is re-sequenced, the fixed assembly orders on the supplying line, related to this parent line are removed. The orders must be inserted again when the supply line is synchronized after re-sequencing the parent line. The positions, available on the supply line, are searched again. All other fixed assembly orders on the supply line, related to other parent lines, are not affected.

The *fixed* assembly order sequence on the linked last line segment of the supplying line is required to:

- Ensure that the assembly orders on the supplying line are delivered on time.
- Ensure that the assembly orders are delivered to the line station on the parent line, in the defined sequence.

Transportation time for linked assembly lines

A supply line linked to multiple parent lines, can be physically present in the same geographical location as the parent lines or can be located in a different geographical area. If the supply line is located in a different geographical area, the time to transport assembled components to the parent line must be taken into account when planning the assembly orders.

Note

The transportation time for the supply of assembled components between the supply line and parent lines must be defined for multicompany assembly scenario as well as the single company assembly scenario. The assembly lines must be logically linked in the assembly line network structure.

The transportation time is calculated based on the following:

- Address of the line station on the supply line.
- Address of the line station on the parent line.

To calculate the transportation time, you must link the last line station of the last line segment of the supply line to a line station on a parent assembly line. In the above example, the last line station L2Z of the last line segment S2Z can be linked to L3A on main line A and/or to L3B on main line B.

You must define the address for the linked line stations and use the distance tables in Freight to calculate the transportation time.

Note

If multiple supply lines are linked to the same line station on the parent assembly line, each supply line-parent line combination can have their specific transportation time.

Important!

The transportation time is displayed only on the line station order related to the last line station of the last line segment on a supply line.

Example

The following example shows a supply line which is linked to two different parent assembly lines.

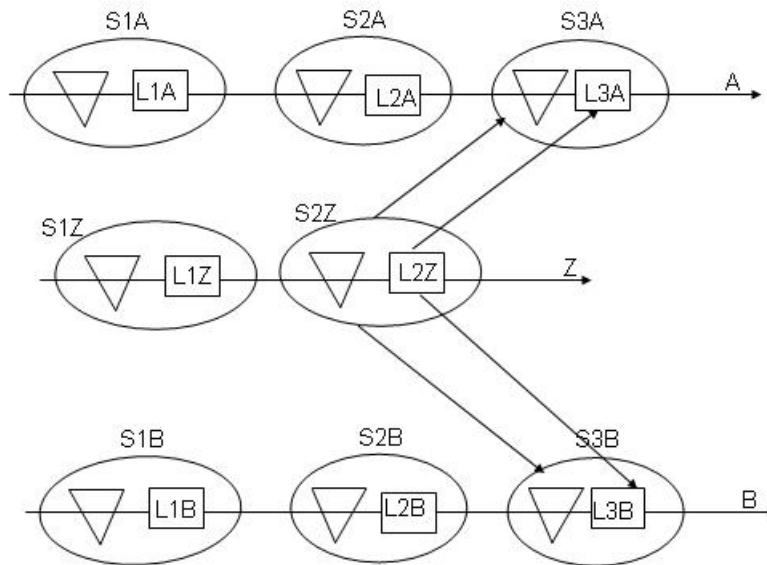

Supply Line z linked to main lines A and B

Legend

- A First main parent line
- B Second main parent line
- Z Supply line for main lines A and B
- S1A to S3A Consecutive line segments on main line A
- L1A to L3A Consecutive line stations on main line A
- S1Z to S2Z Consecutive line segments on supply line Z
- L1Z to L2Z Consecutive line stations on supply line Z
- S1B to S3B Consecutive line segments on main line B
- L1B to L3B Consecutive line stations on main line B
- Inverted Traingle Buffer

The transportation time is taken into account for the following processes:

- **Generating Assembly Orders:** When assembly orders are generated, line station orders (LSO) are also generated. The **Planned Transport End Date** of the line station order related to the last line station of the supplying line, is set to the start date of the assembly order. The **Transport Time** is set to zero.
- **Offsetting line station orders** where the **Assembly Order Status** is **Created**: Offsetting line station orders is based on the transportation time and the defined line segment lead time offset . The **Planned Transport End Date** of the line station order related to the last line station of

the supplying line is set to the end date of the line station order. The value of the **Transport Time** field is set to zero.

Offsetting line station orders where the **Assembly Order Status** is **Sequenced**: Offsetting the line station orders on the supplying line is based on the transportation time in order to determine the start time and end date of the line station orders on the supply line. The **Planned Transport End Date** of the last line station order on the last line segment of the supply line is set to the **Planned Start Time** of the linked line station order on the parent line. The **Transport Time** is calculated using the following formula:

Planned End Time - Planned Transport End Date

While calculating the transport time, the values from the last line station of the last line segment of the supply line are considered.

- **Line sequencing**: The transportation time is taken into account during the Synchronizing Supplying Lines process for assembly orders with the **Sequenced** status. The start time of the (LSO) of the line station on the parent line is offset with the transportation time to determine the end date of the LSO of the last line segment of the supplying line. In case of a multicompany assembly model, this end date on the last line station order is equal to the offline date of the assembly order, on the supplying line.
- **Determining segment schedules**: The transportation time is taken into account when segment schedules are calculated. The transportation time is used to offset line segments when the dates at which the assembly parts are required, are calculated.

Assembly Line Structure Parameters

By setting parameters, you can tailor the functioning of the module to company specific requirements.

Implemented software components

Ensure that the desired parameters are enabled. For example, you can select the following check boxes:

- **Terms and Conditions**
This module is optional. To use terms and conditions, you must select this check box.
- **Assembly (APL/ASC/ASL)**
The Assembly Planning module is used to plan the assembly of product variants and to generate assembly orders in Assembly Control.
- **Product Configurator (PCF)**: This module is optional. To use product configurator, you must select this check box.

Assembly control parameters

Use the Assembly Control Parameters (tiasc0100m000) session to define parameters for Assembly Control.

Note

Changing parameters in this session can have widespread affects throughout the Assembly Control module.

Number Groups and series

You must define the number group and series for the following elements used in Assembly Control:

- Orders
- Clustered line-station orders
- Line station variants

- Reference number

The four number groups and series must differ from each other. You must select a number group that is dedicated to production in the Number Groups (tcmcs0151m000) session.

General parameters

Specify the desired parameters. For example, the **Transaction Processing** parameter is used to do the following:

- Process and store financial transactions.
- Allocate assembly parts.
- Backflush hours and material requirements.

You can set the value of the **Transaction Processing** field to the following:

- **Line Station Based**
Select this parameter for high-volume environments. The data for line-station orders is added together, for each line station, to form one clustered line-station order (CLSO) for each day. Processing is carried out at an aggregated (line station) level. You will receive production results for each period when you use line-station-based transaction processing.
You can use this setting when the following occur:
 - You do not need to trace back to the original assembly order
 - Costs are posted to the assembly line
 - Results are calculated by period by assembly line
- **Order Based**
Select this for low-volume environments. Calculating for each assembly order provides more detailed information and creates more data, which can lead to performance problems if you have many assembly orders. One CLSO is created for each assembly order each day. Processing is carried out for each individual assembly order. You will receive production results for each order when you use order-based transaction processing.

Bucket definition

Start **Manufacturing > Assembly Control > Application Management > Buckets (tiasl1501m000)**.

A bucket is a unit of time used for planning and backflushing. Allocation and backflushing are done per line station per bucket when you use line station based transaction processing, which means that all the line station orders in one bucket are combined. Therefore, the number of transactions are reduced, compared with order based transaction processing. The performance is further enhanced if you use larger buckets, because this reduces the number of transactions.

1. Click **Bucket Definition** on the appropriate menu. The Bucket Definition (tiasl1100m000) session starts in which you can define the buckets based on your requirements.
2. Click **Generate Buckets** on the appropriate menu of the Bucket Definition (tiasl1100m000) session.
3. Check the Buckets (tiasl1501m000) session to see if the buckets have been generated successfully.

Segment schedules

Start **Manufacturing > Assembly Control > Application Management > Segment Schedules (tiapl4500m000)**. Use this session to calculate and display segment schedules.

Segment schedules indicate when the assembly parts that are required for the work in a particular line segment must be delivered to the shop floor warehouse. For each segment on a line, a range of offline periods is defined. For each period, a date is scheduled on which the assembly parts are required. Therefore, every product variant whose requested offline date falls within one of these periods requires its assembly parts for the segment in question on that date. The advantage of these schedules is that the assembly part requirements can be determined from the schedule, if only the requested offline date of the product variant and the segment of the assembly parts is known.

Segment schedules are used for a rough planning of assembly part requirements, especially in the more distant future, that is, the period after the allocation time fence but before the demand time fence. The schedules cover the entire period in the demand time fence, including the allocation time fence. The segment schedules appear in the Segment Schedules (tiapl4500m000) session.

Selling multiples of product variants for assembly

For assembly items, two types of sales order lines exist. Depending on the type of end item, Assembly Planning must be configured differently for both types of sales order lines.

Depending on the setting of the **Sell Multiples of Same Configuration** check box in the Assembly Planning Parameters (tiapl0100s000) session you either:

- **Sell single**
If this check box is cleared, the order quantity on the sales order line has a fixed value of one. To sell multiple end items, you must create multiple sales order lines.
- **Sell multiples**
If this check box is selected, the order quantity on the sales order line is one or more.

The following table displays the differences:

Sell single	Sell multiples
The Sell Multiples of Same Configuration check box in the Assembly Planning Parameters (tiapl0100s000) session is cleared.	The Sell Multiples of Same Configuration check box in the Assembly Planning Parameters (tiapl0100s000) session is selected.
The sales order line has a fixed quantity of one. You maintain sales order lines in the Sales Order Lines (tdsls4101m000) session.	The sales order line has a quantity of one or more. Specified quantities must be whole numbers.

The end item has item type **Generic, Manufactured** or **Product**. The item must be storable in inventory and have item type **Manufactured**, or **Product**. To store items with this item type, they must be linked to items of the type **Generic** in the Configurable Item - Assembly Line (tiapl2500m000) session. To keep track of information on the link between sales order, product variant and assembly line, use demand pegging.

Each sales order line corresponds with one assembly order. Each sales order line corresponds with one or more assembly orders. All assembly orders have an order quantity of one.

The item's serial number is used to determine which completed item is delivered to the customer. The item's specification is used to determine which completed item is delivered to the customer.

The **AssemblyStatus** field of the Product Variants (Assembly) (tiapl3500m000) session displays the progress of the assembly order for the product variant of the sales order line. The **AssemblyStatus** field of the Product Variants (Assembly) (tiapl3500m000) session always has value **Open**.

The requested offline date and planned offline date for the associated assembly order are displayed in the Product Variants (Assembly) (tiapl3500m000) session. No requested offline date or planned offline date can be displayed for the assembly order, the product variant may be in use on multiple assembly orders at once.

The product variant's reference type is **Sales Order**. The product variant's reference type is **Standard Variant**.

You can view demand related date in the Assembly Orders (tiasc2502m000) session for the assembly orders with the **Demand Order Type Sales Order**. Assembly orders for multiples do not have demand order information.

Note

- Selecting **Sell Multiples of Same Configuration** check box does not affect product variants already in use.
- You can configure product variants that contain purchased configurable items. Usually these items are configurable subassemblies that are part of the item structure and issued at the assembly link similarly to other assembly parts.

Process Engineering

Process engineering defines the assembly process for end items.

Process engineering includes processes such as these:

- Defining and assigning the operations to line stations
- Linking flattened assembly parts to operations
- Defining assignments and performing line balancing
- Defining and assigning line rules to line segments

Buffers and line stations

You can use the Work Centers (tirou0101m000) session to create buffers. Each line segment must start with a buffer. At the buffer, the orders wait to be processed and can be rescheduled so that they are carried out in a different sequence.

You can define the line station types in the Stations - Line Segments (tiasl1551m000) sessions.

Assembly Lines

You can use the Assembly Lines (tiasl1530m000) session to create an assembly line.

You can view which line segments belong to the assembly line in the Assembly Line - Line Segments (tiasl1541m000) session. You can view which lines stations belong to the assembly line in the Line Segment - Stations (tiasl1550m000) session.

Line Segments

Start **Manufacturing > Assembly Control > Assembly Lines > Line Segments (tiasl1540m000)**.

Use this session to define line segments. Line segments must always start with a buffer. A line segment must contain a buffer. The presence of one or more line stations is optional but usually a line segment contains line stations. You can use this session to display or edit the employee, that is, the segment planner, who is responsible for planning a particular line segment.

Linking line segments to assembly lines

Start **Manufacturing > Assembly Control > Assembly Lines > Assembly Lines (tiasl1530m000)**

To link line segments to assembly lines, complete the following steps:

1. Select your main assembly line. On the appropriate menu, start the Assembly Line - Line Segments (tiasl1541m000) session.
2. Link line segments to the main assembly line in the correct sequence.

Note

To link the supplying line to a parent line, you must link the last line segment of a supplying line to the line segment on the parent line. The last line station of a supplying line must be linked to the feeding line station on the parent line.

Linking stations to line segments

Start **Manufacturing > Assembly Control > Line Segments > Line Segments (tiasl1540m000)**.

To link stations to line segments, complete the following steps:

1. Select the line segment and select stations from the appropriate menu. The Line Segment - Stations (tiasl1550m000) session starts.
2. Link the buffer and the line stations defined for the segment to your line segment.

Use the Line Segment - Stations (tiasl1550m000) session to display or modify the line stations of an assembly line segment and their relationship to each other. You can display the current effective stations or all the stations for a Line Segment.

You can link line stations in the Work Centers (tirou0101m000) session. To define which line stations are linked to which segment, for a particular date, you can use the details session. If you use PCF, you can use the line definition procedure of Configurator to define which line stations are linked to which segment, for a particular date.

Note

The sequence of line stations starts with the buffer of the current line segment, but ends with the buffer which is related to the succeeding line segment.

The last line station of the last line segment of a supplying line can be connected to a line station which is part of a line segment on the main assembly line. With this link, you indicate to which line station of the main assembly line the assembled item of the supplying line will be supplied.

Defining Assembly Line Assignments

Start **Manufacturing > Assembly Control > Assembly Lines > Assembly Lines (tiasl1530m000)**.

Assignments are used to define process characteristics. Defining assembly line assignments is the process of linking operations and resources, that is, operators and machines, to an assembly line in such a way that the assembly process can proceed without bottlenecks. This set of relations is called an assignment. A cycle time is defined for each assignment. This cycle time indicates the line speed, also known as the takt time of the line. Assignments can be date-effective.

Process characteristics

Several process characteristics can be defined by using assignments. Process characteristics that are applicable to the entire assembly line are defined on the line-level assignment. Process characteristics that apply to line-stations are defined by creating assignments for each line station. All line-station assignments are then linked to the line-level assignments. When the line-level assignment is active, all line-station assignments that are linked to it are effective.

Assignments are defined for an assembly line. For each assignment, you specify the average and non-average cycle time and the period for which the assignment is active. To define the period for which the assignment is active, you must specify the **Effective Date** and the **Expiry Date** for the assignment.

- Average cycle time assignments, which applies to line: Specify and use an average cycle time based on the cycle times of the non-average assignments for the day. The Assembly Control module uses the average assignment in planning. Planning is based on cycle time, calendar, and availability type. An average assignment is valid for a day.
- Non-average cycle time assignments, which applies to line-station: A non-average assignment is based on specific times within a day. Non-average line-level assignments are linked to line-station levels only .

Note

- An average cycle time is not a mathematical average, but is a value that you consider to be a suitable average for the non-average cycle times over the course of a full day.
- Each day must be completely covered by average and non-average assignments. Therefore, ensure that for each moment of the day a non-average assignment is effective, even if no work is performed for a part of the day. Average assignments automatically apply to the whole day. LN takes the hours of the working day from the calendar.
- Non-average assignments are used to define order content. For generated (non-frozen) orders, the order content is based on the first active, non-average assignment of the day. For frozen orders, the order content is based on the non-average assignment that is in effect at the time that the order is frozen.
- Non-average assignments are used to offset the lead time during sequencing. When the order is sequenced, a lead time is calculated for every order. This lead time is based on the cycle times, and the applicable cycle time is retrieved from non-average assignments.

To define process characteristics, complete the following steps:

1. Select the main assembly line.
2. Click **Assignments** on the appropriate menu. The Assembly Line - Assignments (tiasc5510m000) session starts.
3. Define the assembly assignment for the assembly line.

Linking the assignment to line stations

Start **Manufacturing > Assembly Control > Assembly Lines > Assembly Lines**.

To link the assignment to line stations, complete the following steps:

1. Select the assembly line. Click **Assignments** on the appropriate menu . The Assembly Line - Assignments (tiasc5510m000) session starts.
2. Select the *non-average* line assignment that you have defined in the steps above. Click **Line Station Assignments** on the appropriate menu. The Assembly Line - Assignments and Line Stations (tiasc5520m000) session starts.
3. Add the line stations that belong to the assembly line.

For all line stations, you must specify values for the following:

- **ManOccupation**.
- **MachineOccupation**.
- **Number ofCycle Times** for all line stations. The number of cycle times is the time required to process one assembly order in the line station for this assignment. The time is expressed as a number of cycles. For example, if the cycle time is two minutes, ten minutes is expressed as five cycles.

Validating Assembly Lines

The following checks can be performed on the assembly line model integrity:

- There are no divergent line structures and segments present.
- There is correct usage of cost components and calculation office.
- The definition of the line segment structure. For example, if it start with a buffer, connected in a chain and so on.
- The definition of the work centers. The supplying line must feed a line station on the main line.
- The definition of assignments is correct. For example, one or more active average and non-average assignments must be present.
- There must be no gaps in the assembly lines.
- There must be no loops in the assembly line cycles.
- There must be one enterprise unit present for each assembly line.

Start the Assembly Lines (tiasl1530m000) session:

1. Select the assembly line. Click **Validate** on the appropriate menu. The Validate Assembly Lines (tiasl1230m000) session starts.

Note that clicking **Validate** is not a mandatory step. This step is automatically performed when you actualize the assembly lines, which is a step to be completed later on in the process. This intermediate **Validate** option allows you to check the assembly line structure.

2. Ensure that main line and supplying line are specified in the selection range.
3. Click **Validate**. Check the report. If the process runs without errors, LN sets the status of the assembly line structure to *Validated* for the main line and supplying lines.
4. Check that your lines have the Validated status. When a line is created/validated/actualized, lines undergo a change and are set/reset to the Modified status.

Actualizing Assembly Lines

Start the Assembly Lines (tiasl1530m000) session:

1. Select the assembly line. Click **Actualize** on the appropriate menu. The Actualize Assembly Lines (tiasl1231m000) session starts.
2. Click **Actualize**. Check the report. Analyze and correct issues, if required. If the process runs without errors, LN sets the status of the assembly line structure to *Actualized* for the main line and supplying line.

Creating Operations

Start **Manufacturing > Assembly Planning > Engineering > Operations (tiapl1500m000)**. Use this session to define the operations that are used to assemble the item on the line. If the operations are not defined in LN, but delivered by an external source, you cannot change the operations, but only display these operations.

The session is enabled for data entry through the Operation Details (tiapl1100s000) session, if the following conditions apply:

- Your current company is defined as the master company in the Assembly Planning Parameters (tiapl0100s000) session.
- The **External Assembly Parts and Operations** check box is cleared, or the **Test Mode** check box is selected in the Assembly Planning Parameters (tiapl0100s000) session.

Note

A station of type **Line Station** which is linked to the assembly line requires at least one operation. A station of type **Buffer** cannot have operations.

Linking operations to line stations

Start **Manufacturing > Assembly Planning > Engineering > Operations (tiapl1500m000)**.

Operations are one of a series of steps in a routing that are carried out successively to produce an item. Operations are assigned to line-stations.

Use this session to specify the line stations where the operations are carried out, together with the effective date, location, and man occupation of the operations.

To link operations to line stations, complete the following steps:

1. Select the first operation that you have defined. Click **Operation Assignments** on the appropriate menu. The Operation Assignments (tiapl1510m000) session starts.
2. Link the operation to the line station. Set the effective date and the expiry date. Set the **Execution Sequence**, the **ManOccupation**, and the **MachineOccupation** which are used when the **Transaction Processing** parameter is **Order Based** when calculating man/machine hours during backflushing.

Note

If the assembly order operation assignments are changed, you must run the Refresh and Freeze Assembly Orders (tiapl3203m000) session to process the changes.

The purpose of an assembly assignment is to balance the resources over the line stations in a manner that optimizes line performance. Assignments are used to define process characteristics such as cycle time, man occupation, and machine occupation. Several process characteristics can be defined by using assignments. Process characteristics that are applicable to the entire assembly line are defined on the line-level assignment. Process characteristics applied at the line-station level and are defined for other assignments, which are defined by line station and linked to the line-level assignments. When the line-level assignment is active, all line-station assignments that are linked to it are effective.

Product Engineering Introduction

Product engineering refers to the process of designing and developing a device, assembly, or system such that it be produced as an item for sale through some production manufacturing process.

In product engineering, you define the following:

- The Generic item has the following characteristics:
 - The item type is specified as generic
 - The default supply source for the item is assembly
 - The order system is Final Assembly Schedule (FAS)
 - The item is a configurable end item or subassembly.
- Engineering module

For an item to be marked as an Engineering module, the item type must be specified as Engineering module and for which the default supply source is assembly and it is a *virtual* item. Engineering module in Assembly Planning, is a system, or, in other words, a logical unit of assembly parts, that is typically not manufactured as a separate physical unit. For example, the electrical system of a car is the logical unit of all parts required for the electrical system. The electrical system is not manufactured as a separate physical unit, but integrated into the dashboard, doors, and so on. An engineering module has no routings, assembly lines, options, and so on, and is for design and planning purposes only. In the bill of materials (BOM), the engineering module is the top layer of the non-configurable section of the BOM.
- Assembly part

For an item to be marked as Assembly part, the item type must be specified as manufactured/purchased and for which the default supply source is job shop (Manufacturing) or purchase (Purchase).

A general product engineering structure is displayed in the figure below.

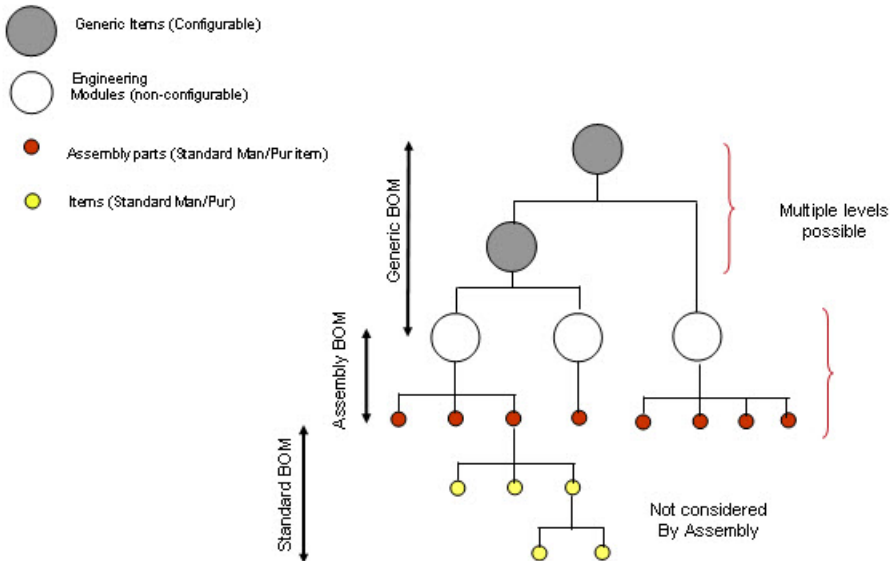

Flattened BOM

Flattening is the process of stripping the engineering product structure to an operational, single-level BOM structure, containing only the parts that are required for assembly operations. Modules that are useful for product engineering to group components that are mounted together are not relevant on the operational level. For performance reasons, the operational product structure should be as lean as possible. Operational BOM (single level) for engineering module is the output of the flattening process.

In LN there are three ways to obtain the flattened parts:

- Import: To import the flattened parts and operations, you must select the **External Assembly Parts and Operations** check box in the Assembly Planning Parameters (tiapl0500m000) session.
- Define manually.
- Obtain through EDM, which involves a flattening procedure.

All the relevant information of lower-level engineering items is stored on the engineering module level. This module saves time because LN does not need to process all the Engineering BOM relations multiple levels deep. See multilevel bill of material.

The BOM flattening is displayed in the figure below.

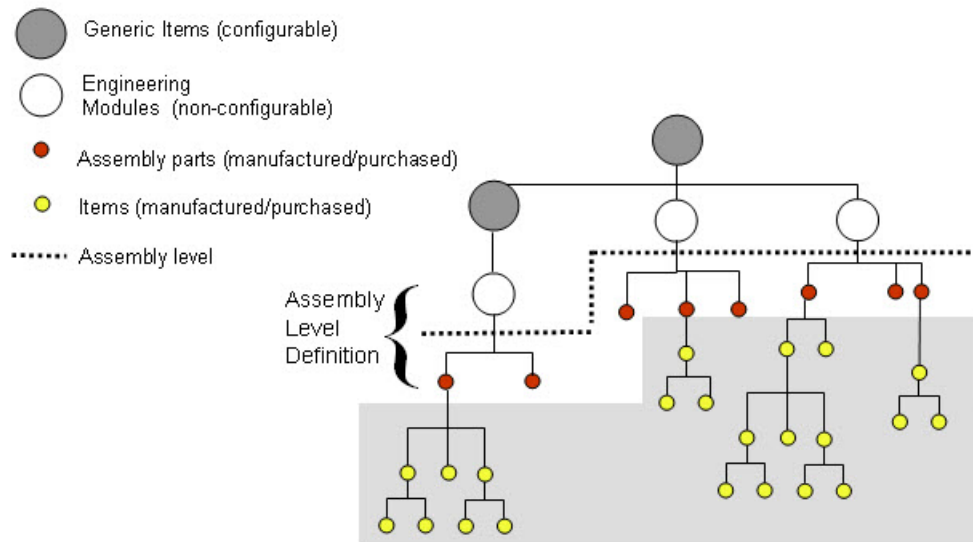

Engineering data management summary

You can use the Engineering Data Management module in Manufacturing to support the registration of a product's design process, dealing with different versions of products. In addition, this module is used to transfer the design data to production.

An overview of the functionality of the Engineering Data Management module is provided here. For further details, refer to the more detailed topics listed at the end of this topic, or the online Help for the appropriate session.

Engineering items

Engineering items are items to which you make design changes. If the design process is finished, you can transfer the changes to actual items. An E-item can exist as several revisions. Each revision is an improved version of the item.

You can attach drawings to E-item revisions with the Document Management module of Data Management.

Engineering bills of material

An engineering bill of material (EBOM) describes the relationships of components to their parent items the same way as a production bill of material (PBOM). The main difference between an EBOM and a PBOM is that EBOMs use different revisions of E-items, rather than having a sequence number to

account for items that are valid on different dates. Record the components of E-items in an EBOM with the Engineering BOM (tiedm1110m000) session.

You can use unit effectivity to model various product configurations of the E-item. For more information on unit effectivity, refer to *Unit effectivity in EDM (p. 107)*.

You can use reference designators in the EBOM to indicate where a component must be mounted on the main item. For more information, refer to Procedure for linking reference designators in the EBOM.

Changing the EBOM

- **Manual changes**

You manually create or change an EBOM for a specific engineering item revision. After approving the revision, the EBOM can be copied to a PBOM. The effective date of the revision is linked to the PBOM lines. The expiry date equals the effective date of the next revision. For more information, refer to Changing EBOMs - Manual procedure.

- **Automatic changes**

You use MBCs to simultaneously perform multiple modifications of engineering data. For an MBC, you can define several actions to add, delete, and replace components in a series of EBOMs. If you have correctly defined your MBCs, you can process several of them together in the Process MBC (tiedm3250m000) session. For more information, refer to Changing EBOMs - Automatic procedure.

- **Semi-automatic changes**

You manually create or change an EBOM, after which you use an MBC to approve the changes. For more information, refer to Changing EBOMs - Semi-automatic procedure.

Unit effectivity in EDM

Unit effectivity can be used to model variations in the design of E-items. You can transfer the unit-effective data to the production environment so the variations are modelled in the production environment.

Item Data

Start **Common > Item Base Data > Item Data > Items (tcibd0501m000)**.

The basic terms of a product engineering structure are explained as follows:

- *Generic item*

Before any manufacturing activities are performed on a generic item, the item must be configured to determine the desired product variant. The Item Type is Generic and the Default Supply Source is Assembly. The Order System for a generic item is Final Assembly Schedule (FAS) and the generic item is a Configurable End item or Subassembly. A generic item is always serialized.

- *Engineering module*

An engineering module is a virtual item. The Item Type is Engineering Module. The Default Supply Source for an engineering module is Assembly.

Engineering module in Assembly Planning, is a system, or, in other words, a logical unit of assembly parts, that is typically not manufactured as a separate physical unit. For example, the electrical system of a car is the logical unit of all parts required for the electrical system. The electrical system is not manufactured as a separate physical unit, but integrated into the dashboard, doors, and so on. An engineering module has no routings, assembly lines, options, and so on, and is for design and planning purposes only. In the bill of materials (BOM), the engineering module is the top layer of the non-configurable section of the BOM.

- *Assembly part*

The Item Type of an assembly part is Manufactured/Purchased. The Default Supply Source for an assembly part is Job Shop (Manufacturing), Purchase (Purchase). An assembly part is a standard item.

Based on this master data structure, the *real* end product, called product variant, can be configured. During the configuration, for example, using PCF, based on the selected features and options, the product variant structure is generated. This process is known as *Solving*, because each product that is going to be assembled is *solved* against a master structure.

Linking product features to generic items

Start **Manufacturing > Product Configuration > Product Features by Configurable Item (tipcf1101m000)**.

Use this session to link general product features and options to generic items. The product-independent features and options defined in an earlier stage are now made product dependent. When you link features to generic items, you can link valid constraints. Recording product features and options forms the basis for configuring product variants for the generic product in question. Product features and options serve as technical descriptions of a specific product variant derived from a generic product.

This section is relevant only if you use PCF. You must link product features to generic items when you define your product model. Features and options linked to generic items are taken as input for defining sequencing rules.

When you configure a product variant, the product features linked to each generic item in this session can be further specified with the options that you recorded in the Options by Product Feature and Configurable Item (tipcf1110m000) session. In principle, all options are possible if the **SelectOption** check box is cleared in the Product Features by Configurable Item (tipcf1101m000) session. Constraints help you include or exclude any options or combination of options required in certain conditions.

Select the generic item for which to define product features and determine the appropriate product feature for each sequence number. For this purpose, use product-independent features that are recorded in the Product Feature (tipcf0150m000) session. After you link a product feature to a generic item, LN automatically copies the general data of the product feature, such as the description of the product feature, the options, the language dependent descriptions, and the texts for product features and options, to the generic item. You can then change this data.

After you select a product feature, you can define the validity period for the product feature and specify which constraint applies. You can choose from any current standard option that is defined earlier for this product feature in the Options by Product Feature (tipcf0160m000) session. You can add extra options or delete existing ones. Explanatory text can be entered with the text manager for the product features and options.

Product features and options are automatically adopted by the lower levels in the configuration structure from the higher levels. Therefore, you need not record these features on each level in the configuration structure unless you want to maintain these options at lower levels in the configuration structure.

On the appropriate menu, click **Options by Product Feature** to maintain options by product feature in the Options by Product Feature and Configurable Item (tipcf1110m000) session. You can copy the product feature data to an existing feature within the same generic item. Options that belong to the product feature, language-dependent descriptions for the feature, options, and option texts are also copied.

Note

Click the Text Manager button to record a detailed description for each product feature. You can view the text in the Product Configurator (tipcf5120m000) session and the text can be printed on external sales documents.

If you change the descriptions of features and options in this session, the descriptions of configured product variants are also changed. For example, if you change the descriptions and print a sales order acknowledgement/RMA for a configured product variant, the changed descriptions occur.

1. Select New Group on the toolbar and enter your generic item.
2. Link features to the generic item.

For more information, refer to *How to define a product model* (p. 125).

Mask by Item/Item Group

Start **Common > Item Base Data > Masks > Mask by Item/Item Group (tcibd4505m000)**. A mask is a template that specifies the structure of identification codes such as serial numbers, lot codes, handling units, and Kanban IDs.

Note

You can define the mask for serialized item and link the mask to the item/item group.

For more information, refer to *Defining a mask* (p. 129).

Creating Generic BOMs

When a product is configured using *Product Configuration (PCF)* (p. 122), a generic BOM must be defined for all components of the generic item.

A generic BOM is used to define the generic product and product engineering structure. Based on this master data structure the end product, called product variant, can be configured. During the configuration, based on the selected features and options, the product variant structure is generated.

Generic BOM's are created in the Generic BOMs (tipcf3110m000) session. If assembly lines are used to manufacture the items, the **Configurator** check box must be selected in the Assembly Planning Parameters (tiapl0100s000) session.

Note

If the **Configurator** check box in the Assembly Planning Parameters (tiapl0100s000) session is cleared, the BOM is created through the Generic Bill of Material (tiapl2510m000) session.

Changes in the generic BOM are not applied existing product variant structures.

If the **Multilevel PCF Choice Structure** check box in the Product Configuration Parameters (tipcf0100m000) session is selected, you can use extra generic levels in the product structure for a multilevel selection structure.

Creating sales price lists for generic items

In the Generic Price Lists (tipcf4101m000) session the configuration-based sales price of the generic item is defined. When defining the price for a new group of generic items the **Sales Price List** option in the **Price List Type** field must be selected.

Assembly BOMs and operations

Start the Assembly BOM and Operations (tiapl2520m000) session to view and maintain the assembly parts, operations, and line stations that are required for a specific engineering module.

Restrictions

If the **External Assembly Parts and Operations** check box in the Assembly Planning Parameters (tiapl0500m000) session is selected, the flattened parts and operations are delivered from an external source.

You cannot change the data in the current session, except when you work in **Test Mode**.

If the check box is cleared, the assembly parts and operations are flattened during the calculation of the assembly part requirements. You can modify data in this session only if your current company is defined as the master company.

Procedure

After you change the data in this session, you must run the following sessions:

- Calculate Assembly Part Requirements (tiapl2221m000)
- Refresh and Freeze Assembly Orders (tiapl3203m000)

Operations independent from assembly parts

To define operations which are not linked to a specific assembly part, leave the Assembly Part field empty. LN takes these operations into account when it creates line-station variants.

Select *New* group on the toolbar and enter your engineering module.

Note

You can define an assembly BOM line which does not contain an assembly part, but only operation and location data.

An assembly BOM line which contains only an assembly part and no operation and location details, is considered as an incomplete assembly BOM line and is not taken into consideration by LN.

Assembly Line Material Supply

Different supply methods are available for the supply of shop floor warehouse which are related to one or multiple line stations on the assembly line.

The internal and/or external supply methods are as follows:

- Supplier
- Internal warehouse
- Production

The material supply methods are as follows:

- **Push**
The shop floor warehouse is supplied based on planning information.
- **Pull**
The shop floor warehouse is supplied based on a supply trigger.
 - **KANBAN**
The supply is based on a manual trigger, such as the scan of a bar code. This method is mostly used for floor stock items for which no registration at shop floor warehouse is required.
 - **TPOP**
The supply is triggered by a SIC run for the shop floor warehouse concerned.

- Order Controlled / Batch (OCB)**
 The supply is completed anonymously for multiple assembly orders together, based on triggers in the assembly process.
- Order Controlled / SILS (Supply In Line Sequence)**
 The supply is completed for every assembly order separately, based on triggers in the assembly process. The parts are delivered Just-in-time in the sequence that products are passing along the assembly line.

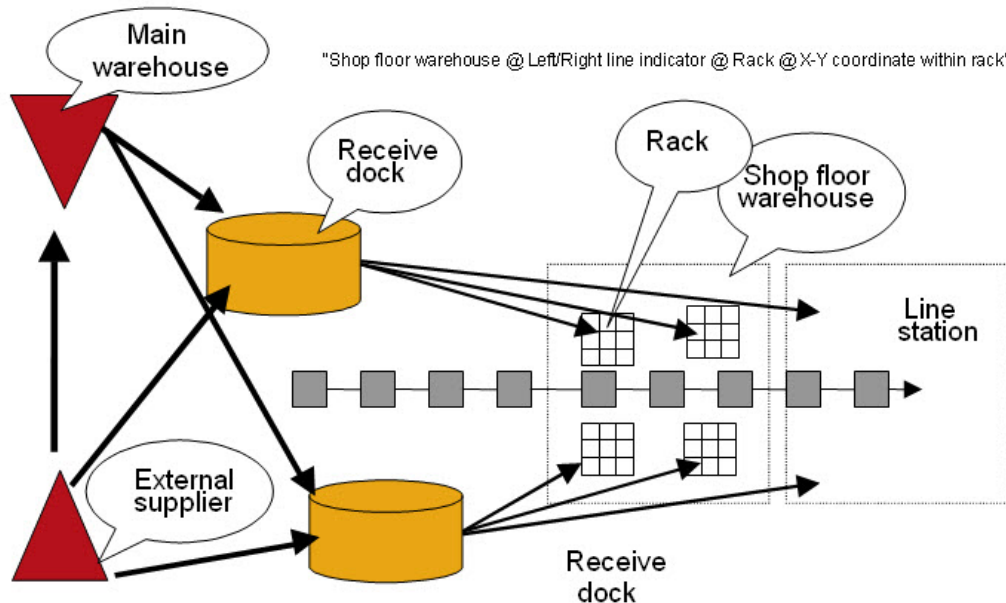

Linking generic items to assembly lines

Use this session to define which generic item can be produced on which assembly lines. LN requires this information to determine the master company of the generic item. Several processes can run only in the master company. For example, if you enter a sales order, LN creates a product variant in the master company. In the Configurable Item - Assembly Line (tiapl2100s000) details session, you can specify a basic sales price and standard cost.

Assembled items through warehousing after roll-off from main line

Store finished generic items - setup

This topic describes how to set up the items to be able to store the finished end product of an assembly order in inventory.

To store a finished generic item in inventory, you must define *two* items: a generic item and a standard item.

Both items represent the same physical item. In Assembly Control, you use the generic item. In Sales Control and Warehousing, you use the associated standard item.

To specify which standard item is associated with the generic item, use the Configurable Item - Assembly Line (tiapl2500m000) session.

Item settings

For the generic item and the standard item, use the following item settings:

Session	Field	Generic item	Standard item
Items (tcibd0501m000)	Item Type	Generic	Manufactured or Product
Items (tcibd0501m000)	Serialized	Yes	Yes
Items (tcibd0501m000)	Revision Controlled	(Not used)	No
Items (tcibd0501m000)	Order System	FAS	FAS
Items - Warehousing (whwmd4500m000)	Serials in Inventory	(Not applicable)	Yes
Items - Warehousing (whwmd4500m000)	Lots in Inventory	(Not applicable)	(See below)

The **Serials in Inventory** check box must be selected because Warehousing would otherwise not be able to distinguish between product variants.

Additional instructions

- The generic item and the standard item must have the same inventory unit.
- If you use unit effectivity, you must define both items as unit effective items in the Items (tcibd0501m000) session.
- If the standard item is lot controlled, you must use the lot-in-inventory type of lot control. To make an item lot controlled, select the **Lot Controlled** check box in the Items (tcibd0501m000) session. To use the lot-in-inventory type of lot control, select the **Lots in Inventory** check box in the Items - Warehousing (whwmd4500m000) session.

Standard cost calculation of the standard item

The standard item must have an effective cost component structure. The standard inventory valuation functionality for items in inventory requires such a cost component structure.

To specify the inventory valuation method, in the Item Data by Warehouse (whwmd2510m000) session, select a value in the **Inventory Valuation Method** field.

To obtain the most accurate inventory valuation, select an inventory valuation method based on actual costing. The recommended inventory valuation method is **Serial Price (Serial)**.

If the inventory valuation method is **Standard Cost**, which is not an actual costing method, you must calculate a standard cost in the Standard Cost Calculation module. In this case, LN values the item against the calculated fixed transfer price (FTP) of the standard item and ignores differences between the product variants.

Storing finished generic items

Introduction

In LN, an item of type generic cannot be stored in inventory. To store a finished generic item in inventory, you must associate the generic item with a standard item. The item type of the standard item is **Manufactured** or **Product**.

Both items represent the same physical item. In Assembly Control, you use the generic item. In Sales Control and Warehousing, you use the associated standard item.

You can use this setup to carry out post-assembly operations in regular work centers after an item leaves the assembly line.

Note

If you send the item to the customer immediately upon completion of the assembly order, you only need the generic item.

Setup

The items must have the following properties:

- The order system of the generic item *and* the standard item must be **FAS**.
- Both items must be serialized items.
- If you use unit effectivity, both items must be unit effective items.

To specify which standard item is associated with the generic item, use the Configurable Item - Assembly Line (tiapl2500m000) session.

Restrictions

If a manufactured item is associated with a generic item, you cannot do the following with that item:

- Use the item in Purchase Control
- Create a bill of material (BOM) for the item, or use the item as a component in another BOM

- Create a production order for the item, other than a rework order
- Plan the item in Enterprise Planning, because the item's order system is **FAS**

You cannot return an FAS item to the assembly line for rework.

Note

You can create routings for post-assembly operations of the standard manufactured **FAS** item.

Procedure

Sales order entry

Based on the standard item that you entered, LN retrieves the generic item that is linked to this standard item in the Configurable Item - Assembly Line (tiapl2500m000) session.

LN sets the **Delivery Type** field on the sales order line to **Warehouse**.

You must define the generic item 's product variant in one of the following ways:

- Configure the generic item in Product Configuration or in Assembly Planning, as determined in the **Configurator** check box in the Assembly Planning Parameters (tiapl0100s000) session.
- Select a previously configured product variant.
- Use an external tool/system to deliver the configured product variant to LN.

Note

If a generic item has an associated standard item, you can still enter the generic item on a sales order line.

Assembly order handling

If a sales order line has an item with the order system **FAS**, LN creates an assembly order in the Assembly Control module by running the Generate Assembly Orders (tiapl3201m000) session. The item on the assembly order is the generic item.

When the assembly order is sequenced, LN generates the end item's serial number.

When the assembly order's final operation is completed, LN completes the following actions:

1. LN generates a warehousing order to receive the finished item in inventory. The item on the warehousing order is the standard item.
The assembly order status becomes **Production Completed**.
2. LN sets the **Ownership** field on the inbound-order line to **Company Owned**.
3. After the item is received in inventory, and any required inbound inspection has been performed, the assembly order gets the status **Completed**.

If the item is rejected or destroyed after inspection, the relevant product variant obtains the status **Canceled**. If a product variant obtained the status **Canceled**, to continue processing

the assembly order, manually cancel the sales order and create a sales order by using another product variant.

The product variant is **Canceled** only when the following conditions are met:

- The **Sell Multiples of Same Configuration** check box is selected.
- A manufactured FAS item is listed on the sales order line.

LN links the as-built structure to the standard item instead of to the generic item.

Note

Before you can release the sales order line to Warehousing, a sales order line for a standard **FAS** item must have a serial number.

Post-assembly operations

To perform additional operations on an item after the item comes off the assembly line, create a rework order.

Delivering to customers directly from the assembly line

Delivering to customers directly from the assembly line process is based on generic assembly items. For sales order processing, the **Delivery Type** field on the sales order is **Work Center**. A warehouse order is created and will be delivered from the work center to the customer.

For more information, refer to *Product variants in Warehousing* (p. 130)

Calculating Standard Cost and Actualizing Assembly Lines

Step 1: Calculate standard cost for all your defined purchased and manufactured items.

Validate that LN calculates the standard cost accurately. You can use the Calculate Standard Cost (ticpr2210m000) session to automatically calculate the standard cost.

Step 2: Actualize cost component structures for defined generic and FAS items.

- **Defining assembly line costing data**

Use the Assembly Line Costing Data (ticpr0115m000) session to store costing data that is related to an assembly line, or to a combination of an assembly line and an item. You can enter a cost component chart to post costs on a detailed level. In the **Standard Cost Component Scheme** field, you can enter a chart to which detailed cost components are linked. If a cost component chart is defined for an assembly line, costs are posted on the detailed cost components in the chart. If the **Standard Cost Component Scheme** field is empty, all costs are posted to the aggregated cost components. If the **Transaction Processing** field in the Assembly Control Parameters (tiasc0100m000) session is **Line Station Based**, you can enter costing data for an assembly line. If the **Transaction Processing** field is **Order Based**, you can enter costing data for a combination of an assembly line and an item.
- **Actualizing assembly line costing data**

Use the Assembly Line Costing Data (ticpr0115m000) session to actualize the assembly line costing data, which results in an effective cost component structure by assembly line and item. The effective cost component structure contains the aggregated cost components that are defined for the item in the Item - Costing (ticpr0107m000) session. If you entered a chart for an assembly line, the detailed cost components that were defined for the chart are included in the effective cost component structure.

You can view the effective cost component structure in the Effective Cost Component Structure by Assembly Line and Item (ticpr3162m000) session. In the **Effective Date** field, the date on which the assembly line costing data is actualized is displayed.

Note: You must actualize the costing data for all lines that are part of your assembly line model.

- **Defining assembly line surcharge data**

Use the Assembly Line Surcharges (ticpr1180m000) session to define surcharges for an assembly line. Surcharges are extra costs in an item's standard cost or valuation price, for example, handling costs or inspection costs. A surcharge serves as a discount if the amount or percentage entered is a negative value. If you use order-based transaction processing, surcharges are defined for a combination of an assembly line and an item. If you use line-station-based transaction processing, surcharges are defined for an assembly line. You cannot define a fixed surcharge amount for assembly-line-based transaction processing. The surcharges are posted to the assembly line when the line is closed. For order-based-transaction processing, the surcharges are posted to the assembly line by order.

Note: If the **Transaction Processing** field in the Assembly Control Parameters (tiasc0100m000) session is set to **Order Based**, you can enter surcharges for a combination of assembly lines and generic items. If you select the **Line Station Based** option in the **Transaction Processing** field of the Assembly Control Parameters (tiasc0100m000) session, you can enter only surcharges for an assembly line.

- **Actualizing assembly line surcharges**

Use the Actualize Assembly Line Surcharges (ticpr2280m000) session to actualize the assembly line surcharges and the assembly line surcharge bases. Effective assembly line surcharges and effective assembly line surcharge bases are created, which are used in assembly line costing. The effective date is the date on which the process is run. You can display the effective assembly line surcharges in the Effective Assembly Line Surcharge (ticpr3150m000) session. You can display the effective assembly line surcharge bases in the Effective Assembly Line Surcharge Base (ticpr3160m000) session.

Select your assembly line from the assembly line's from-to range. For other options, you can use default settings. Click **Actualize** to continue.

Note: You must actualize the surcharges for all lines that are part of your assembly line model.

Line sequencing and rule types in Assembly Control

Assembly orders generated by Assembly Planning can be sequenced by using the sequencing engine, resulting in a line mix and line sequence. During this sequencing process, line rules are taken in to account like clustering assembly orders based on items characteristics, or blocking assembly orders based on capacity rules.

The assembly line can be dedicated to one model, or to a mixed model. For example, a large number of product variants can be produced on the same assembly line.

Four major aspects of line sequencing are discussed:

- Sequence rules
- Sequence process
- Rescheduling
- Line sequence status

SEQUENCE RULES

Sequence rules are made up of the following elements:

- Mixing process
- Mix rules, which exist in three types:
 - Capacity restriction rules
 - Proportional rules
 - Relative proportional rules
- Placement rules, which exist in three types:
 - Clustering rules
 - Blocking rules
 - Priority rules

The (re)mixing process in Assembly Control

You can remix the orders within the *Assembly Control* (p. 115) module by using the Remix Line Mix (tiasl3220m000) session. Rules are defined for particular option combinations. Remixing attempts to schedule the orders so that the number of orders for each option combination is as close as possible to the maximum number of orders for each option combination. The better the mix, the better the sequence quality.

Mix rules

There are three types of mix rules:

- **Capacity Restriction**
The total capacity of the line is limited, for example: maximum 500 cars with option combination CityCar in one day.
For **Capacity Restriction** rules, you can select one of three types of dispersion:
 - **Average Dispersion** The option combination is spread evenly throughout the line sequence.
 - **Sliding Window Avg. Disp.** A window is a certain number of adjacent sequence positions. That window is being slid position by position. Within each window the product sequence is optimized. Adjacent sequence positions means a continuous range of sequence positions. In each window the option combination is dispersed as evenly as possible. For example, each group of 10 positions should have the same number of RedCars.
 - **Sliding Window Cap. Resr.** Within each window, there is a limit to the number of orders for the option combination. For example, no more than two RedCars in any window of 10 positions.
- **Proportional**
Option combinations must be present in fixed proportion of the total order, for example, the ratio of CityCar to other orders must be 1:2.
You can define two dispersion types for **Proportional** rules:
 - **Average Dispersion** The option combination is spread evenly throughout the line sequence.
 - **Sliding Window Avg. Disp.** In each window, there is a maximum ratio of a given option combination and any other option combination. For example, for every RedCar option combination, there must be at least one other option combination within any four option combinations (ratio = 1:2, window =4).
- **Relative Proportional**
The same as **Proportional**, except that the **Method of Dispersion** is always **Relative Dispersion**. You must specify a second option combination in which the first option combination is dispersed in relation to. The option combination is placed in a particular relation to another option combination. For example, red cars and blue cars can only be assembled alternately; you cannot assemble two red cars in a row.

During remixing, the priority of orders is taken into account, as described in one of the following paragraphs.

Because rules can conflict with each other, it is possible that not all sequence rules can be met. In that case you can give some rules a higher priority. However, this results in a less efficient order sequence, and you must solve these conflicts by redesigning the assembly process, not by performing more line sequencing.

Placement rules

Placement rules are used to determine how products are placed in relation to other products. There are three types of placement rules:

- **Clustering**

Use this rule to place similar option combinations next to each other when changing between option involves a long change-over time. For example, place all blue cars next to each other, because changing paint color takes a long time.

You also use this rule to sequence the clusters based on the characteristics defined in the Option Combination Lists (tiasl1511m000) session in the *Assembly Control* (p. 115). Based on the option combination list that is attached to each cluster. Used the options defined in the combination list Assembly Control can sequence the clusters as efficiently as possible.

Each cluster can be assigned a priority (0 to 99). Additionally, priority can be given to sequencing specifically by selecting a high priority number in the sequence in the option combination list linked to the cluster.

- **Blocking**

Certain option combinations must not be placed next to other option combinations. For example, light colors must not be painted after dark colors to minimize effects of paint contamination.

Clustering Example

In this example, the assembly orders and their option combinations are planned for a day on line segment 1.

Order 1	Option combination red
Order 2	Option combination blue
Order 3	Option combination black
Order 4	Option combination red
Order 5	Option combination blue
Order 6	Option combination black
Order 7	Option combination red
Order 8	Option combination blue
Order 9	Option combination black
Order 10	Option combination red

The option combination list Color is defined in *Assembly Control* (p. 115) as:

Option combination red	sequence 1
Option combination black	sequence 2
Option combination blue	sequence 3

When the assembly orders are sequenced in *Assembly Control* (p. 115), based only on the clustering rule Color, the result for line segment 1 is:

Order 1	Option combination red
Order 4	Option combination red
Order 7	Option combination red
Order 10	Option combination red
Order 3	Option combination black
Order 6	Option combination black
Order 9	Option combination black
Order 2	Option combination blue
Order 5	Option combination blue
Order 8	Option combination blue

Blocking Example

In this example, the assembly orders and their option combinations are planned for a day on line segment 1.

Order 1	Option combination red
Order 2	Option combination blue
Order 3	Option combination black
Order 4	Option combination red
Order 5	Option combination blue
Order 6	Option combination black
Order 7	Option combination red
Order 8	Option combination blue
Order 9	Option combination black
Order 10	Option combination red

The option combination list Color is defined in *Assembly Control* (p. 115) as:

Option combination red	Option combination blue
Option combination red	Option combination red

The list Color is linked to the blocking rule Color, which is linked to assembly line 1. This rule says that the color red cannot be followed by the color blue or by the color red.

One result of this rule is the following sequence:

Order 1	Option combination red
Order 3	Option combination black
Order 2	Option combination blue
Order 4	Option combination red
Order 6	Option combination black
Order 5	Option combination blue
Order 8	Option combination blue
Order 7	Option combination red
Order 9	Option combination black
Order 10	Option combination red

Priority

Priority rules are enforced in the following order:

1. Orders with a later **Requested Offline Date** are given a lower priority.
2. Orders that are sold (a demand order) have priority over orders not yet sold.
3. Assembly orders with a lower priority number are processed first (for example, orders with a priority number of 1 are processed before orders with a priority number of 4). You define the order priority in the Assembly Order (tiasc2100s000) session.
4. Cost function value.

THE SEQUENCING PROCESS

When you add new orders to an assembly line, LN generates in the Simulate and Create Line Sequences (tiasl4200m000) session an initial sequence for the line for the appropriate offline date.

A line segment that follows a buffer can only be sequenced, if the buffer has more than one random access place. To define a buffer's number of random access places, enter a value in the **Number of Random Access Places** field in the Stations (tiasl1545m000) session.

Note

When you confirm a sequence, LN generates the As-built structure for the end item, such as the VIN number and header in the case of a car. You can edit the structure with the Serial End Item - As-Built Headers (timfc0110m000) and Serial End Item - As-Built Components (timfc0111m000) sessions. The serial numbers of the components are generated when you freeze the sequence. When you use the Print Work Instructions (tiasc5450m000) session, a space is provided on the printed form for you to enter the serial number of the components.

RESCHEDULING

You can also manually alter the sequence with the Reschedule Assembly Orders (tiasl4220m000) session. The session uses two types of rules:

- **Move**
An order is taken from one position and inserted into another position. All orders in between the two positions are shifted one position towards the initial position.
- **Swap**
Two orders are interchanged, and nothing else is changed.

The automatic sequencing process uses the swap method. You can change the maximum swap/insert distance that is used in the automatic sequence generation in the Remix/Sequence Parameters (tiasl4110m000) session.

When you have swapped orders to another line mix, you can run the Remix Line Mix (tiasl3220m000) session for a better sequence.

LINE SEQUENCE STATUS

A line sequence can have one of the following statuses:

- **Planned**
- **Started**
- **Completed**

A line sequence has the status **Planned** when it is first created. When the first line-station order is completed, the status becomes **Started**. When the last line station order is completed, the status of that segment becomes **Completed**.

You can see the status in the Line Segment - Line Sequence (tiasl4500m000) session.

You can sequence the assembly orders on two levels:

- Assembly line level (line mix)
- Line segment level (line sequence)

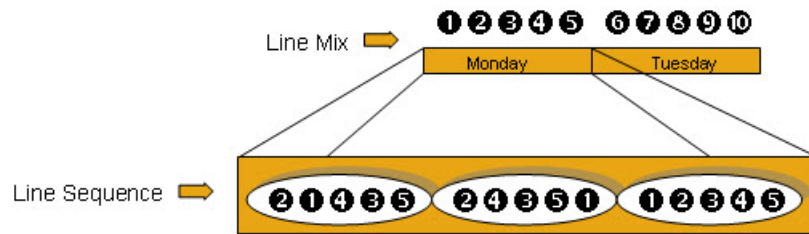

An initial line mix is generated by Assembly Planning. Remix assembly orders consider assembly orders with the status Planned and Sequenced, and use the existing assembly line mix as the starting point.

The remix process is important under these circumstances:

- When a backlog must be cleared.
- When an existing mix must be improved.
- Because offline dates of assembly orders have changed.
- Priority on assembly orders is altered.

A line sequence is generated based on the line mix. A line sequence specifies the order in which assembly orders must start on the corresponding line segments. For each line segment that is present in the assembly process, a line sequence must be generated. The line sequence algorithm takes the assembly order with the status Planned and Sequenced within a specific production period as input. On the last line segment of a supplying line, a line sequence is *fixed*. The line sequence of the connected line segment on the parent line determines the line sequence of the last line segment on the supplying line.

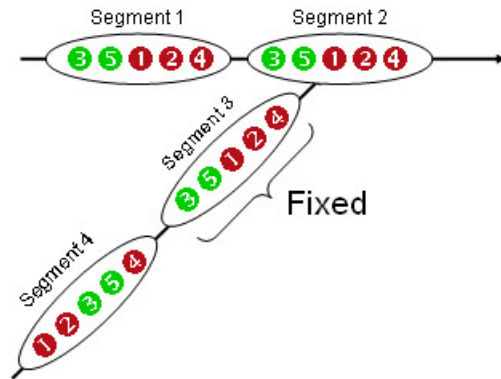

After sequencing, you can manually reschedule the assembly orders per line segment. Two types of rescheduling are possible:

- Move assembly orders



- Swap assembly orders (1 and 4)



Defining Option Combinations

Use this session to display option combination codes and their descriptions. An option combination is a grouping of product options, for example, color or style, that are related to an assembly order. Each option combination is either a single option or a combination of other option combinations.

To define option combination and option combination lists in the Option Combinations (tiasl1510m000) session, complete these steps:

1. Define an option combination. For option combinations, the following rules exist:
 - **Blocking rules**
An option combination list can be used as a blocking rule. Blocking rules determine which options are not allowed to succeed particular other options.
 - **Clustering rules**
An option combination list can be used as a clustering rule. Clustering rules can define multiple option combinations in a cluster, and clusters those combinations. LN attaches a sequence number to every option combination.
2. You can define option-combination lists in the Option Combination Lists (tiasl1511m000) session.
Select your defined option combination. Click **Expressions** on the appropriate menu. The Option Combination - Expressions (tiasl1560m000) session starts. Define the expression.

Logical operator	Description
()	Use brackets to nest statements. Statements within brackets are treated as separate clauses that must be calculated first. You must start and end the whole expression with brackets.
or, and, not	Normal Boolean operators.
-	Blank.

To build the logical structure of the expression, you can use the given logical operators.

You can use relational operators to build the logical structure of the expression. Relational operators define the relationship between the feature and the **Option**.

=	equal to
>	greater than
<	less than
>=	greater than or equal to
<=	less than or equal to
<>	not equal to

To build the logical structure of the expression, you can use the given logical operators:

Note

Click **Check Validity** on the appropriate menu of the Option Combination - Expressions (tiasl1560m000) session to check the validity of the defined expression(s).

Example

(BodyColor = RED)	Selects all red cars.
(BodyColor = RED _ and WheelColor = GREEN)	Selects only red cars that have green wheels.
(BodyColor = RED _ or WheelColor = GREEN)	Selects all cars which are painted red plus all cars that have green wheels (so 'or' means and/or).

Define option combination list

Start **Manufacturing > Assembly Control > Line Segments > Option Combination Lists (tiasl1511m000)**.

Use this session to view lists of option combinations. You can use these lists in the Line Rules (tiasl1570m000) session to define rules stating that certain option combinations must either be sequenced next to each other (clustered), or not sequenced next to each other (blocked). You can define which option combinations are in each list in the Option Combinations List - Option Combinations (tiasl1565m000) session.

In this session, you must specify the colors to be *grouped* together and the sequence of grouping, for example, first group Red, next Blue, and last White. This serves as input for defining the sequence engine rules.

1. Define the option combination list.
2. Select the option combination list that you have defined in the previous step. Use the appropriate menu and navigate to *Option Combinations*.
3. Add the desired option combinations.

Create line rule

Start **Manufacturing > Assembly Control > Line Segments > Line Rules (tiasl1570m000)**.

Use this session to view or define sequencing rules to apply to assembly lines. These rules are used to calculate penalty costs in the Simulate and Create Line Sequences (tiasl4200m000) session.

Line rule definition is based on features and options which are linked to your generic item. Multiple line rules can be linked to a single line segment.

For more information, refer to *Line sequencing and rule types in Assembly Control (p. 59)*.

Link line rule to line segment

Start **Manufacturing > Assembly Control > Line Segments > Line Segments (tiasl1540m000)**.

After the line rule is created, the line rule must be linked to a line segment. For this segment, the sequence engine generates an optimized sequence of assembly orders.

1. Select the line segment. Click **Line Rules** on the appropriate menu. The Line Segment - Line Rules (tiasl1571m000) session starts.
2. Select *New* on the toolbar and link the line rules to the line segment. Set the effective date and the expiry date.

You can link several rules, each of which is valid for a different date range. You can also link more than one rule to the same segment for the same date range. In that case, if there is a contradiction, the rule with the highest priority takes precedence

Defining Sequence Parameters for Line Segments

Start **Manufacturing > Assembly Control > Line Segments > Line Segments (tiasl1540m000)**.

Use this session to maintain and display the remixing/sequencing parameters for a user. The parameters are displayed per segment.

These parameters are required when you run the sequencing engine. The parameters are linked to a line segment and are user dependent. Only the user who runs the sequencing engine can select the sequence parameters that are defined by the same user.

These are important remix/sequence parameters:

- **Local**

- **Number of Local Runs**

- The number of times LN carries out a calculation to determine the best sequence in the line segment.

- **Local Maximum Swap Distance**

- The maximum number of positions between orders that you swap in the Simulate and Create Line Sequences (tiasl4200m000) session. If you increase the swap distance, the quality improves because more swaps are possible. If you increase the swap distance, each sequencing simulation run takes longer.

- **Local Run Count**

- The maximum number of attempted swaps per sequencing run. LN checks to see whether this number has been exceeded after each series of swaps, determined by the maximum swap difference and number of orders. When the value of this field has been exceeded, one sequencing run has been completed.

- **Local Non-improvement Count**

- The number of times that LN swaps orders in the selected segment without any improvement to the cost before stopping the sequencing run.

- **Global**

- **Number of Global Runs**

- The number of times LN carries out a calculation to determine the best sequence order in the line segment. In the Remix Line Mix (tiasl3220m000) session, this parameter is taken into consideration to determine the number of times the process of remixing must be carried out to arrive at a better line mix.

- **Global Maximum Swap Distance**

- The maximum number of positions between orders that you swap in the Simulate and Create Line Sequences (tiasl4200m000) session. If you increase the swap distance, the quality improves because more swaps are possible. If you increase the swap distance, each sequencing simulation run takes longer.

- **Global Run Count**

- The maximum number of attempted swaps per sequencing run. LN checks to see whether this number has been exceeded after each series of swaps, determined by the maximum swap difference and number of orders. When the value of this field has been exceeded, one sequencing run has been completed.

- In the Remix Line Mix (tiasl3220m000) session, this parameter is taken into consideration. The parameter represents the maximum number of attempted swaps per remixing run.

- **Global Non-improvement Count**

The number of times that LN swaps orders in the selected segment without any improvement to the cost before stopping the sequencing run.

In the Remix Line Mix (tiasl3220m000) session, this parameter is taken into consideration. This parameter represents the number of times the orders are swapped in the selected segment without any improvement to the cost before stopping the remixing run.

To define sequence parameters for line segments, complete the steps below.

1. Click **Remix/Sequence Parameters** on the appropriate menu of the Line Segments (tiasl1540m000) session. The Remix/Sequence Parameters (tiasl4110m000) session starts. You cannot start this session from the menu browser.
2. Check that you are logged as a user. Only the user who runs the sequencing engine can select the sequence parameters that are defined by the same user. Select *New* on the toolbar to enter sequence parameters for the line segment.

The following are sequencing options available in the Simulate and Create Line Sequences (tiasl4200m000) session:

- **Local Improvement**
If this check box is selected, LN optimizes the sequence for the segment selected in the **Pivot Segment** field. You can select the **Neighbor Checking** check box to optimize the sequence for a segment.
- **Neighbor Checking**
If this check box is selected, LN takes account of the segments immediately before and after the specified segments during the optimization process. This process gives rise to a sequence that is translatable to the neighbor segments, which means that the sequence changes are feasible. You can select this check box only if the **Local Improvement** check box is selected. If the **Global Improvement** check box is selected, LN automatically selects the **Neighbor Checking** check box.
- **Global Improvement**
If this check box is selected, LN optimizes the sequence for all the segments that you select in this session.

The following are offsetting options available in the Simulate and Create Line Sequences (tiasl4200m000) session:

- **Backlog**
If this check box is selected, LN takes a backlog into account when it calculates offset. Therefore, the first order is planned at the beginning of the period you specify in this session.
- **Actual Times**
If this check box is selected, LN calculates the offset. LN takes into account when the last order was reported completed on the last line station of a segment. Next time you run this session to replan a line sequence, LN takes the difference between the planned end time and actual end time into account.

Creating Sales Order Lines

Start **Sales > Sales Orders > Sales Orders > Sales Orders (tdsls4100m000)**.

If the **Sell Multiples of Same Configuration** check box is selected in the Assembly Planning Parameters (tiapl0500m000) session and the sales order line contains a manufactured assembly item, the product variant linked to the sales order line will have the reference type *Standard Variant*.

A product variant with the reference type *Standard Variant* can be used in the following ways:

- Can be reused, and therefore linked to multiple sales order lines.
- Can have multiple assembly orders referring to it, but assembly orders always have an order quantity of 1.
- Cannot be reconfigured on a specific sales order line.
- Can be removed, that is, unlinked, from a sales order line

Create a sales order header and a sales order line for the manufactured assembly item.

Sales order entry

To define a sales order line for a generic item that must be stored in inventory after completion, enter the associated standard item on the sales order line.

Based on the standard item that you entered, LN retrieves the generic item that is linked to this standard item in the Configurable Item - Assembly Line (tiapl2500m000) session.

LN sets the **Delivery Type** field on the sales order line to **Warehouse**.

You must define the generic item 's product variant in one of the following ways:

- Configure the generic item in Product Configuration or in Assembly Planning, as determined in the **Configurator** check box in the Assembly Planning Parameters (tiapl0500m000) session
- Select a previously configured product variant

Note

If a generic item has an associated standard item, you can still enter the generic item on a sales order line. If you enter the generic item on a sales order line, LN sets the **Delivery Type** field on the sales order line to **Work Center** and you cannot store the finished item in inventory.

If, during sales order line entry, LN displays the confirmatory question *Configure Variant Now?*, you must click **Yes** to configure the assembly item.

Note

This section is valid only when you use PCF in combination with the Assembly Control module for product configuration.

For more information, refer to:

- *Product Configuration (PCF)* (p. 122)
- *PCF procedures* (p. 123)

After you save the sales order line, the price is obtained from price list.

Note

If the **Sell Multiples of Same Configuration** check box is selected, you can retrieve the product variant number from either the sales order line grid or the **Item** tab on the sales order line. The product variant number is displayed as an attribute on the **Specification** tab of the sales order line.

You can obtain a product variant as follows:

- During the configuration process at order entry, using PCF. The section below explains the detailed procedure to obtain a product variant at sales order entry.
- Creating one manually in Assembly Planning. You can use the Product Variants (Assembly) (tiapl3500m000) session to create a product variant in the Assembly Planning module.
- Importing one from an external system, for example, sales configurator. If an external configurator is used, the product variant must be imported and stored in the Product Variants (Assembly) (tiapl3500m000) session.

Product variants in Sales

In Sales, you can generate product variants for the following item types:

- Generic non-FAS items.
- Generic FAS items that must not be stored in inventory.
- Standard FAS items that must be stored in inventory.

Note

- In LN, an item of type generic cannot be stored in inventory. To store a finished generic FAS item in inventory, you must associate the generic item with a standard item. Both items represent the same physical item. In Assembly Control, you use the generic item. In Sales

Control and Warehousing, you use the associated standard item. For more information, refer to *Store finished generic items* (p. 123).

- If the **Sell Multiples of Same Configuration** check box is cleared in the Assembly Planning Parameters (tiapl0500m000) session, the order quantity for standard manufactured FAS items that must be stored in inventory is limited to one on a sales order line. If the **Sell Multiples of Same Configuration** check box is selected in the Assembly Planning Parameters (tiapl0500m000) session, you can enter a standard manufactured FAS item with an order quantity greater than one and sell multiples of the same assembly product variant. Therefore, several assembly orders are linked to one sales order line. To identify the product variant, the various assembly orders and the sales order line have the same specification. A standard manufactured FAS item is also called a manufactured assembly item. For more information, refer to *Selling multiples of product variants for assembly* (p. 35) and *Assembly items* (p. 117).
- For FAS items, the **Configurator** check box in the Assembly Planning Parameters (tiapl0500m000) session determines whether you must configure the item in Product Configuration or whether LN automatically generates a product variant for the item in the Product Variants (Assembly) (tiapl3500m000) session.

Linking product variants

In the Sales Order Lines (tdsls4101m000) and Sales Quotation Lines (tdsls1501m000) sessions, a product variant can be linked as follows:

- By configuring a product variant from these sessions.
- By inserting an existing product variant in the **Product Variant** field.

The table below describes various permutations and combinations with respect to linking of the product variants.

Item order system	Store generic item in inventory?	Associated item	Item on sales order/quotation	Configure by PCF parameter	Configure product variant	Select product variant from session:	Comments
Non-FAS	Not applicable	Not applicable	Generic	Not applicable	Product Configurator (tpcf5120m000)	Product Variants (tpcf5501m000)	-
FAS	No	No	Generic	Selected	Product Configurator (tpcf5120m000)	Product Variants (Assembly) (tiapl3500m000)	-

FAS	No	No	Generic	Cleared	Not applicable	Product Variants (Assembly) (tiapl3500m000)	The product variant is automatically generated.
FAS	Yes	Yes	Standard	Selected	Product Configurator (tiapl5120m000)	Product Variants (Assembly) (tiapl3500m000)	-
FAS	Yes	Yes	Standard	Cleared	Not applicable	Product Variants (Assembly) (tiapl3500m000)	The product variant is automatically generated.

Reviewing Product Variants

A product variant in the Assembly Control module is a unique configuration of a generic or standard item. The unique configuration results from the configuration process information such as feature options, company, and assembly line.

Start **Manufacturing > Assembly Planning > Configuration > Product Variants (Assembly) (tiapl3500m000)**.

Use this session to display or maintain the configuration, reference, price, and status information of the product variants that were created from sales orders, and product variants that were entered manually.

A product variant stores the data of a configured item, or of multiple configured items that belong to the same product structure. The data that is stored is, for example, the roll-off line for the assembly order, the requested and planned offline date, and so on. The product variant represents all the configured items that make up a configured product structure. Any reference made to a configured item is made by way of the product variant.

Because product variants contain data from production and sales, the product variant is updated as far as the progress of the production process permits, if this data is changed. You can change the data in the current session, which is the Product Variants (Assembly) (tiapl3500m000) session, only if your current company is defined as the master company, and you work in Test Mode, which is defined in the Assembly Planning Parameters (tiapl0500m000) session.

Calculating assembly part requirements

Start **Manufacturing > Assembly Planning > Configuration > Calculate Assembly Part Requirements (tiapl2221m000)**.

Use this session to calculate the assembly part requirements for product variants whose assembly parts are not yet allocated. If the product variants and product variant structures are generated, the assembly part requirements can be calculated and assembly orders can be created. Assembly part requirements are calculated based on the product variant structures and the flattened assembly parts. The assembly part requirements are calculated for product variants whose planned offline date falls within the demand time fence. The demand time fence is defined in the details of the Assembly Planning Parameters (tiapl0500m000) session. The calculation is based on segment schedules that indicate on which date the assembly parts are required for each segment, based on the offline date of the assembly order. Segment schedules are displayed in the Segment Schedules (tiapl4500m000) session. When the assembly part requirements are calculated, they are transferred to Enterprise Planning.

The assembly part requirements are calculated for product variants that meet the following criteria:

- The requested offline date falls within the demand time fence, which is defined in the Assembly Planning Parameters (tiapl0100s000) session.
- The **Assembly Parts Allocated** check box is cleared.
- The **To Be Deleted** check box is cleared.
- The **AssemblyStatus** is **Open**, **Planned**, or **Frozen**.

Note

- If you enter a **Date** outside the demand time fence, a warning message is displayed.
- Product variants that fall within the demand time fence can fall within the allocation time fence. In that case, the assembly parts are likely to be already allocated by Assembly Control, that is, by the Build Assembly Part Allocation (tiasc7240m000) session. If the parts are not allocated, or if not all the parts are allocated, the assembly lines for which the parts are not allocated are taken into account by the current session. Refer to the Product Variant - Assembly Lines (tiapl3520m000) session for the allocation status by assembly line.
- Assembly parts for which the **Floor Stock** check box is selected in the Assembly BOM and Operations (tiapl2520m000) session are not taken into account by the current session.
- The current session calculates the assembly part requirements based on segment schedules, which is a rough calculation useful for high volumes. The segment schedules appear in the Segment Schedules (tiapl4500m000) session.
- As opposed to the assembly part allocation that is carried out in Assembly Control, the current session calculates the requirements for all companies and assembly lines in the selection simultaneously.

To ensure that the assembly part requirements are calculated according to the latest data, the current session first performs the following steps:

- Updates segment schedules. The segment schedules are updated if changes are detected that affect the schedule, or if you selected the **Update Segment Schedules** check box.

- Updates allocation status. The allocation status is read from Assembly Control and copied to Assembly Planning. The allocation status appears in Assembly Planning in the Product Variant - Assembly Lines (tiapl3520m000) session and the details of the Product Variants (Assembly) (tiapl3500m000) session.
- Generates product variant structures of the product variants that meet the selection criteria described previously. After the product variant structure is created, the **Product Variant Structure generated** check box is selected in the details of the Product Variants (Assembly) (tiapl3500m000) session. Note that the product variant structure is generated only if the **External Product Variant Structure** check box is cleared in the Assembly Planning Parameters (tiapl0100s000) session.

After these preparation steps, the assembly parts requirements are calculated for the selected product variants, and the requirements are transferred to Assembly Planning for all the related companies. The requirements are transferred using files that store the requirements by company by date. The directory to which these files are written is set in the **Assembly Parts Requirements Directory** field in the details of the Assembly Planning Parameters (tiapl0100s000) session.

After the assembly part requirements are calculated and transferred, a completion report is created.

If errors occurred, the **Messages** button is enabled. Click this button to display the error messages.

Assembly orders

Assembly orders are created for product variants whose planned offline date falls in the assembly order time fence of the roll-off line. The assembly orders are created by Assembly Planning, but are stored and executed in Assembly Control.

In a multicompany situation, assembly orders are created for each company. Assembly orders can only be created for assembly lines that are actualized, which means that the lines are released for use in the production process.

Assembly order statuses

An assembly order can have one of the following statuses:

- **Created**
- **Sequenced**
- **In Progress**
- **Production Completed**
- **Completed**
- **Closed**
- **Canceled**

Assembly order progress

- An assembly order has the status **Created** when it is initially generated by Generate Assembly Orders (tiapl3201m000) session. When this happens, [line-station orders](#), [line-station variants](#) and [exchangable configurations](#) are generated. The line station orders are generated both for the main line and the supplying lines of the same company. You must have already defined the assembly line structure (segments and line stations).
- The assembly order is **Sequenced** as described in the *Line sequencing and rule types in Assembly Control (p. 59)* online manual topic. When the order is sequenced, you can start it from the [appropriate](#) menu of the Buffer - Assembly Orders (tiasl6520m000) session. You can arrange for a request from another line station, for an order to be started, using the Request Start - Assembly Order on Line Station (tiasc4200m000) session (or as part of workflows with the *Process Trigger Definition (tiasl8100m000) (p. 127)* session).
- When the first line-station order is reported complete, the status of the assembly order becomes **In Progress**. You can report a line station order complete with the Line Station - Assembly Orders (tiasl6510m000) or Report Line Station Order Complete Using Bar Code (tiasc2211m000) session. If the lines station orders are reported complete in a different sequence from the planned sequence, LN automatically reschedules the orders.

Before you can carry out the assembly order, you must allocate assembly parts. See the Help of the Build Assembly Part Allocation (tiasc7240m000) session for more details.

You can swap orders after they have been started, as long as they still have [exchangable configurations](#). Use the Exchange Configurations (tiasl4240m000) session.

Production Completed: If the order is reported completed, LN sets the assembly order to **Production Completed** status.

Completed: As soon as Warehouse Management finishes the inbound procedure for produced items that must be delivered into inventory, the assembly order will get the **Completed** status. When line-station orders are reported complete, you can *Assembly backflushing (p. 134)* their hours and materials.

Closed: You can close assembly orders with the Close Assembly Orders (tiasc7210m000) session (from the Assembly Line - Line Mix (tiasc2501m000) [appropriate](#) menu). When you close the assembly order, LN creates the financial transactions for that assembly order. If that is impossible, LN produces error messages. The [WIP transfer](#) bookings are recorded in the [calculation office](#) of the assembly order.

Serialized items in assembly control

The as-built structure for assembly lines is generated when you have confirmed the line sequence. If you are using serialized items (that is, the **Serialized** check box is selected in the Items (tcibd0501m000) session), the serial numbers (for example the VIN of a car) are generated at this stage.

The following actions you perform on assembly orders, affect the status of the as-built structure (that is, the serial numbers) of the serialized items of the assembly order:

- Confirm line sequence
- Report assembly order complete
- Close assembly order

- Reopen assembly order
- Undo completed line station order

Line station variants and line station orders

Using the similarity of order data per line station line station variants reduce the data storage and improve performance in the execution system. When the order content on a specific line station is the same for multiple orders, that content is only stored once. This similar information is stored in a line station variant. The assembly orders only have a link to Line Station Variants.

Example

You are making cars with many different features, including two types of wheels (broad and narrow). For the line station where the wheels are fitted, all cars with broad wheels are one line station variant, all cars with narrow wheels are another LSV, no matter what other specifications they have, because the other specifications are not relevant to the wheel line station.

An LSV can be shared by a number of assembly orders. That means that operations and material usage on that line station is the same of all of those assembly orders.

Purpose

An LSV is a device to reduce unnecessary data, and so enhance performance. If you have one thousand orders for products, and the operations and materials at the first line station of the line are all identical, there is no point in storing identical information one thousand times. LN determines that the orders are all identical, and makes one LSV. When a new assembly order is generated, LN check the materials and operations for the order. If these are the different from existing LSVs, a new LSV is created.

Sessions

You can display LSVs in the Line Station Variants (tiasc2520m000) session and print them in the Print Line Station Variants (tiasc2420m000) session. You can display and update the materials linked to LSVs in the Line Station Variant - Assembly Parts (tiasc2121m000) session, and display and update the operations in the Line Station Variant - Operations (tiasc2122m000) session (if the LSVs are order specific).

Order-specific LSVs

LSVs are automatically generated by LN. If you want to alter the operations or components of an LSV, you must make the LSV order specific, by carrying out the following procedure:

1. In the Assembly Order - Line Station Orders (tiasc2510m000) session, select the LSV. The line station order must be **Frozen**.

2. On the appropriate menu, click **Make Order Specific**. LN makes a unique line station variant, which you can see in the Assembly Order - Line Station Orders (tiasc2510m000) session.
3. On the appropriate menu, click **Line Station Variants**.
4. The Line Station Variants (tiasc2520m000) session starts.
5. Select the LSV.
6. On the appropriate menu, click **Operations**.
7. The Line Station Variant - Operations (tiasc2122m000) session starts. Modify the operations as required.
8. You can modify the assembly parts linked to the operations from the appropriate menu of the Line Station Variant - Operations (tiasc2122m000) session.

Line station order

When assembly orders are generated, line station orders are also created. A line station order is a production order for an assembly line station.

A line station order can have the following status:

- **Planned**
- **Frozen**
- **Ready to Start**
- **Completed**
- **Closed**

When line station orders are generated, the status is set to **Planned**.

Clustered line station order

Represents all the material requirements for a line station for a day. A CLSO consists of user-defined buckets. The material requirements are combined for each bucket.

In Assembly Control, transactions can be carried out per line station and per period, instead of per order. LN can combine the same materials for a specific period into one material line. After doing so, the cumulated quantity is stored in the CLSO. This accumulation reduces the number of transactions that are necessary, because the transactions are performed for a specific bucket.

CLSOs are used in assembly part allocation and in backflushing to combine materials for a line-station order (for a day).

Parameters

The **Transaction Processing** parameter determines the use of CLSOs. This parameter is defined in the Assembly Control Parameters (tiasc0100m000) session, and can have the following values:

- **Line Station Based** Only one CLSO is created for each line station each day.
- **Order Based** One CLSO is created for each assembly order.

CLSOs are used in assembly part allocation and in backflushing to combine materials for a line station order. A CLSO covers an entire day, in line-station based transaction processing, or an assembly order, in order-based transaction processing. The data for each time bucket is kept separate. In line-station based transaction processing, each time bucket results in a separated warehousing order line for the assembly part allocation. In order-based transaction processing, an individual warehouse order is generated for each CLSO.

Through the appropriate menu you can perform the following actions:

- Change the status of a CLSO from **Closed** to **Open**.
- Start the Clustered Line Station Order - Assembly Part Requirements (tiasc7140m000) session to view the assembly part requirements for each CLSO.

Sequencing Assembly Orders

Start **Manufacturing > Assembly Control > Line Segments > Simulate and Create Line Sequences (tiasl4200m000)**.

For more information, refer to *Line sequencing and rule types in Assembly Control (p. 59)*.

Generating a sequence of assembly orders per line station is a mandatory step in the procedure, even if you do not intend to use the sequencing engine. The assembly orders on each line must have the status **Sequenced** before you can continue with the process.

The sequencing process starts from the roll-off line. The sequencing engine sequences assembly lines individually, starting from the roll-off line and progressing backwards. For the supplying line, we must re-run the sequence engine .

The following are the sequencing options that are available in the Simulate and Create Line Sequences (tiasl4200m000) session:

- **Local Improvement**
If this check box is selected,, LN optimizes the sequence for the segment selected in the **Pivot Segment** field. You can select the **Neighbor Checking** check box to optimize the sequence for a segment.
- **Neighbor Checking**
If this check box is selected,, LN takes account of the segments immediately before and after the specified segments during the optimization process. This action gives rise to a sequence that is translatable to the neighbor segments, which means that the sequence changes are feasible. You can select this check box only if the **Local Improvement** check box is selected. If the **Global Improvement** check box is selected, LN automatically selects the current check box.
- **Global Improvement**
If this check box is selected,, LN optimizes the sequence for all the segments that you select in this session.

1. Define the sequence selection criteria.
2. Click **Generate** and check if error messages are logged. If required, troubleshoot the messages. If you want to first evaluate generated sequences, do not select the **Confirm Sequence** option but first evaluate your run. Select your *run number* from the **Sequence Quality** group box, and click **Evaluate**. LN displays the sequence of the assembly orders on different line segments through a report.
3. Click **Confirm** to confirm the *run number*. LN saves the generated sequence, which you can view, per line segment, in the Line Segment - Line Sequence (tiasl4500m000) session. Verify that the generated sequence is saved.
4. Repeat steps 2 and 3 for sequencing your supplying line.
5. Open the Assembly Orders (tiasc2502m000) session and check if your assembly orders have the **Sequenced** status. Verify that the related line station orders are still in the **Created** status.
6. Open the Assembly Orders (tiasc2502m000) session and verify the following:
 - The assembly orders with the **Sequenced** status have a serial number.
 - LN generates an *As-Built* header.

Serialized items in Manufacturing

You can use serial numbers to track and trace the items in inventory, production orders, purchase orders, sales orders, service, and so on. You can determine, for example, to which production order a specific end item belongs, which components are used and where the components originate.

To set up serialized items

If you want to use serial numbers in LN, you must set up data first. For information, refer to To set up serialized items.

For serialization in Manufacturing, you must also set a number of parameters in the Production Order Parameters (tisfc0100s000) session:

- **Moment of Generating Serial Numbers**
- **Only Serialized and Lot Controlled Items in As-Built Components**
- **As-Built Status Handling.**

As-built structure

The as-built structure is an important concept for serialized (end) items in Manufacturing. The as-built structure reflects the configuration of a product. Two additional concepts are important:

- **As-built header**
The as-built header contains the individual serialized end items for a specific production order or assembly order.
- **As-built component**
From a specific serialized item in the as-built header, you can zoom to the as-built components, that is, the components that are used in the configuration. The components can be serialized or non-serialized. Dependent on the setting of the **Only Serialized and Lot Controlled Items in As-Built Components** field in the Production Order Parameters (tisfc0100s000) session, all components can be viewed, or only the serialized and lot controlled components.

You can use the as-built structure and the serial numbers in the structure for several purposes:

- For information purposes, for example, how the product is assembled, and which components are used. If you want to use the serial numbers for configuration-information purposes only, you can choose to clear the **Serial Tracking** check box in the Item - Warehousing (whwmd4600m000) session. In this way, the data is not stored for tracking and tracing.
- As a basis for a product structure ([physical breakdown](#)), which you can use in Service for service and maintenance purposes. For more information, refer to [To create a physical breakdown from an as-built structure](#) and [To maintain physical breakdowns](#). If service engineers use the as-built structure, having anonymous items displayed in the as-built structure can be useful. In that case, you must clear the **Only Serialized and Lot Controlled Items in As-Built Components** check box in the Production Order Parameters (tisfc0100s000) session.
- To update tracking sessions in Warehousing so that you can track and trace the serialized items that you used in production to purchase orders, sales orders, and so on. You must select the **Serial Tracking** check box in the Item - Warehousing (whwmd4600m000) details session to use serial numbers for tracking purposes.

Serial numbers

Operators in the job shop usually enter the serial numbers in the as-built structure. To enter the numbers, you can, enter or scan bar codes. You can also choose to generate the serial numbers for end items in the as-built header. In that case, you must define a [mask](#). The moment that serial numbers in the header are generated depends on the setting of the **Moment of Generating Serial Numbers** field in the Production Order Parameters (tisfc0100s000) session. This parameter is important because this enables you to determine yourself on which moment in the production process you can assign serial numbers to the items in a production order.

You can view and maintain the as-built header in the Serial End Item - As-Built Headers (timfc0110m000) session, and the as-built components in the Serial End Item - As-Built Components (timfc0111m000) session. For more information, refer to [To maintain as-built headers and as-built components](#)

Masks for serialized items

If you want be able to generate serial numbers, you must use [masks](#). You can define masks on three levels:

- **Item level**
You can define a mask for a specific item in the Mask by Item/Item Group (tcibd4505m000) session.
- **Item group level**
You can define a mask for a specific item group in the Mask by Item/Item Group (tcibd4505m000) session.
- **Company level**
You can define a mask for a specific company in the Item Base Data Parameters (tcibd9199m000) session.

If you want to generate serial numbers, LN searches for a mask, successively on the item level, the item group level, and the company level. If no mask is defined, no as-built structure is generated, and you must manually enter serial numbers, for example, by typing or scanning. Without a mask, the **Moment of Generating Serial Numbers** parameter in the Production Order Parameters (tisfc0100s000) session is no longer applicable.

Refer also to *Defining a mask* (p. 129).

To use serial numbers during the production order process

Serial number handling in Manufacturing is embedded in the production order process. The **As-Built Status Handling** field in the Production Order Parameters (tisfc0100s000) session determines how serialized items in Manufacturing are handled:

- **Automatic**
If the **As-Built Status Handling** field is set to **Automatic**, the actions a user performs on the production order result in status changes of the serialized end item. For example, if a number of items on a production order is reported as completed or rejected, the status of the same number of items in the as-built header automatically changes to **Manual**.
- **Manual**
If the **As-Built Status Handling** field is set to **Manual**, you must first update the status of the items in the as-built header before you can complete, or reject the items on the last operation of a production order, or on the production order itself. For example, if you have completed two serialized items, and you have rejected one, you must first change the status of two items in the as-built header to **Assigned**. Only then can you report these quantities as completed and rejected on the production order.

For more information, refer to *Working with serialized items in Manufacturing* (p. 88).

If you want to handle serialized items in the most detailed way, you must use the Production Warehouse Orders (timfc0101m000) session. This session is especially useful to issue, return, and cancel serialized components for a specific end item.

Working with serialized items in Manufacturing

During production, operators in the job shop can link, manually or automatically, serial numbers to end items in a production order and to specific components. This handling of serial numbers in Manufacturing is embedded in the production order process. When handling serialized items, the status of the serialized items is changed.

For example, when serial numbers are assigned to items, the status changes to **Assigned**. In addition, the status of the serialized item also expresses other handling of the serialized items, such as rejection, sending to the warehouse, and receiving in the warehouse.

You can view and maintain the status of the serialized items in the **Serial Status** field in the Serial End Item - As-Built Headers (timfc0110m000) session.

Possible Values

- **Created**
The initial status of the serialized end item, after the serial numbers are generated.
The serial numbers are generated by LN based on the value of the **Moment of Generating Serial Numbers** field in the Production Order Parameters (tisfc0100s000) session. When the field is set to **Manually** you can generate serial numbers at any point in the process.
- **Assigned**
The product is finished. A serial number is linked to the serialized item, and the serialized item is ready to be transferred to Warehousing.
- **Sent to Warehouse**
The serialized item is reported as complete and sent but not yet received in the warehouse. The inbound procedure must still be carried out.
- **Received in Warehouse**
The serialized item is received in the warehouse. The inbound procedure is carried out.
- **Recalled from Warehouse**
The serialized item is in the warehouse but must be returned to the job shop.
- **Returned from Warehouse**
The serialized item was in a warehouse in Warehousing but is now returned to Job Shop Control. The outbound procedure must still be carried out.
- **Transferred to As-Maintained**
The serialized item is transferred to Service.
- **Rejected/Scrapped**
The serialized item is rejected in the production order. The serialized item cannot be transferred to as-maintained in Service, and cannot be used in another production order. Rework using a rework order is still possible.

Note

Newly created as-builts cannot have this status.

- **Rejected**
The serialized item is rejected in the production order. An item with this status is sent to quarantine or scrapped.
- **Quarantined**
The serialized item is rejected in the production order and is sent to a quarantine warehouse or designated quarantine location.
- **Scrapped**
The serialized item is rejected in the production order and is not eligible for rework.

Assigning serial numbers

You can handle serialized items in Manufacturing manually or automatically, which is determined in the Production Order Parameters (tisfc0100s000) session by the **As-Built Status Handling** field.

If the **As-Built Status Handling** field is set to **Automatic**, the actions a user carries out on the production order automatically result in status changes of the serialized end items. If a number of serialized items on a production order is reported as completed or rejected, the status of those items in the as-built header changes automatically to **Assigned**.

- **Advantages if the As-Built Status Handling field is Automatic**
You can handle the serialized items for Manufacturing directly in the session in which you report your operation or production order as completed (the Report Operations Completed (tisfc0130m000) session, or the Report Orders Completed (tisfc0520m000) session). Consequently, you do not need to start an extra session (the Serial End Item - As-Built Headers (timfc0110m000) session) to handle serialized items.
You can easily use a scanning device. The scanned numbers are directly entered in the session in which you report the operations or the production order as completed.
- **Disadvantage if the As-Built Status Handling field is set to Automatic**
If you want to report as completed a number of serialized items with specific serial numbers, you must report these items as completed one by one in the Report Operations Completed (tisfc0130m000) session, or the Report Orders Completed (tisfc0520m000) session.

Example

A production order has an order quantity of five serialized end items.

One of the five items is finished. As usual, you report the item as completed in the Report Operations Completed (tisfc0130m000) details session (on the last operation), or in the Report Orders Completed (tisfc0520m000) details session.

You must enter the serial number of the item in the **Serial Number** field. The serial status of that item in the Serial End Item - As-Built Headers (timfc0110m000) session changes from **Created** to **Assigned**.

If the **As-Built Status Handling** field in the Production Order Parameters (tisfc0100s000) session is set to **Manual**, you must first update the status of the items in the as-built header (Serial End Item -

As-Built Headers (timfc0110m000) session) before you can complete or reject the items on the last operation of a production order.

The advantage if the **As-Built Status Handling** field is set to **Manual**:

- You can maintain and handle several *specific* serial items simultaneously in the Serial End Item - As-Built Headers (timfc0110m000) session. For example, you can reject a number of specific serialized items, or you can set the status to **Assigned** for a number of specific serialized items.

The disadvantage if the **As-Built Status Handling** field is set to **Manual**:

- You always need two sessions to handle serialized items: First you must change the status of serialized items in the Serial End Item - As-Built Headers (timfc0110m000) session. After that, you must report the items completed or rejected in the Report Operations Completed (tisfc0130m000) session, or the Report Orders Completed (tisfc0520m000) session.

Example

Suppose that you have finished two items (serial numbers 10400003 and 10400004) out of a production order quantity of three. Usually, you must directly report those two items as completed in the Report Operations Completed (tisfc0130m000) details session (on the last operation), or in the Report Orders Completed (tisfc0520m000) details session. However, if the **As-Built Status Handling** field in the Production Order Parameters (tisfc0100s000) session is set to **Manual**, you must first change the serial status of items 10400003 and 10400004 in the Serial End Item - As-Built Headers (timfc0110m000) session from **Created** to **Assigned**. Only then can you report the two items as completed.

Transportation time for linked assembly lines

A supply line linked to multiple parent lines, can be physically present in the same geographical location as the parent lines or can be located in a different geographical area. If the supply line is located in a different geographical area, the time to transport assembled components to the parent line must be taken into account when planning the assembly orders.

Note

The transportation time for the supply of assembled components between the supply line and parent lines must be defined for multicompany assembly scenario as well as the single company assembly scenario. The assembly lines must be logically linked in the assembly line network structure.

The transportation time is calculated based on the following:

- Address of the line station on the supply line.
- Address of the line station on the parent line.

To calculate the transportation time, you must link the last line station of the last line segment of the supply line to a line station on a parent assembly line. In the above example, the last line station L2Z of the last line segment S2Z can be linked to L3A on main line A and/or to L3B on main line B.

You must define the address for the linked line stations and use the distance tables in Freight to calculate the transportation time.

Note

If multiple supply lines are linked to the same line station on the parent assembly line, each supply line-parent line combination can have their specific transportation time.

Important!

The transportation time is displayed only on the line station order related to the last line station of the last line segment on a supply line.

Example

The following example shows a supply line which is linked to two different parent assembly lines.

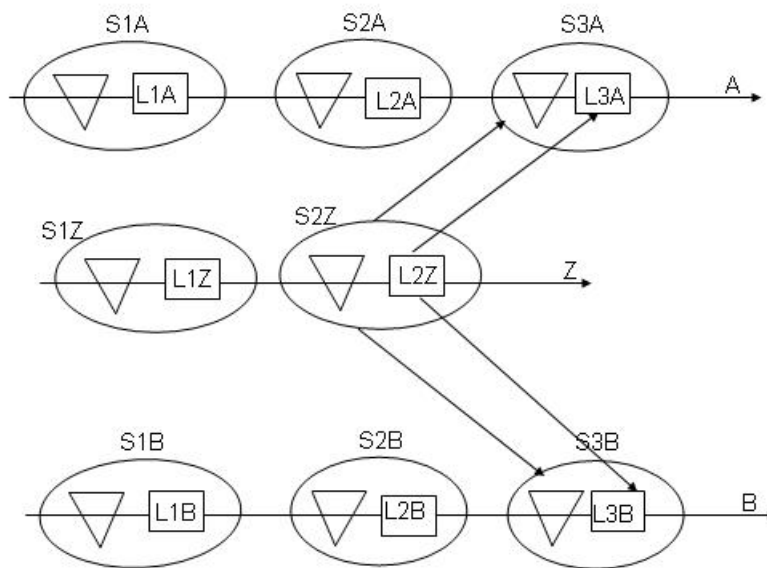

Supply Line z linked to main lines A and B

Legend

- A First main parent line
- B Second main parent line
- Z Supply line for main lines A and B
- S1A to S3A Consecutive line segments on main line A
- L1A to L3A Consecutive line stations on main line A
- S1Z to S2Z Consecutive line segments on supply line Z
- L1Z to L2Z Consecutive line stations on supply line Z
- S1B to S3B Consecutive line segments on main line B
- L1B to L3B Consecutive line stations on main line B
- Inverted Traingle Buffer

The transportation time is taken into account for the following processes:

- **Generating Assembly Orders:** When assembly orders are generated, line station orders (LSO) are also generated. The **Planned Transport End Date** of the line station order related to the last line station of the supplying line, is set to the start date of the assembly order. The **Transport Time** is set to zero.
- **Offsetting line station orders** where the **Assembly Order Status** is **Created**: Offsetting line station orders is based on the transportation time and the defined line segment lead time offset . The **Planned Transport End Date** of the line station order related to the last line station of

the supplying line is set to the end date of the line station order. The value of the **Transport Time** field is set to zero.

Offsetting line station orders where the **Assembly Order Status** is **Sequenced**: Offsetting the line station orders on the supplying line is based on the transportation time in order to determine the start time and end date of the line station orders on the supply line. The **Planned Transport End Date** of the last line station order on the last line segment of the supply line is set to the **Planned Start Time** of the linked line station order on the parent line. The **Transport Time** is calculated using the following formula:

Planned End Time - Planned Transport End Date

While calculating the transport time, the values from the last line station of the last line segment of the supply line are considered.

- Line sequencing: The transportation time is taken into account during the Synchronizing Supplying Lines process for assembly orders with the **Sequenced** status. The start time of the (LSO) of the line station on the parent line is offset with the transportation time to determine the end date of the LSO of the last line segment of the supplying line. In case of a multicompany assembly model, this end date on the last line station order is equal to the offline date of the assembly order, on the supplying line.
- Determining segment schedules: The transportation time is taken into account when segment schedules are calculated. The transportation time is used to offset line segments when the dates at which the assembly parts are required, are calculated.

Building Assembly Part Allocations

The following points are covered in this help topic:

- Allocation mode: **Order Based** or **Line Station Based**
- Allocation of assembly parts to the shop-floor warehouse
- Time buckets
- Allocation of assembly parts

Allocation mode

The allocation of assembly parts can be carried out in one of the two following modes, which are defined in the **Transaction Processing** field of the Assembly Control Parameters (tiasc0100m000) session:

- **Order Based**
The assembly parts are allocated to the shop floor warehouse of the line station for every assembly order. LN creates one clustered line-station order (CLSO) for every line station order.

- **Line Station Based**

The assembly parts are allocated to the shop floor warehouse for each bucket. The parts for all the assembly orders that fall within each bucket are combined and allocated together. LN creates a separate CLSO for each line station.

Existing assembly orders are taken into account when orders are generated and material requirements are recalculated.

Determining to which shop-floor warehouse the parts are allocated

You link a shop-floor warehouse to a line station in the **Shop Floor Warehouse** field of the Work Centers (tirou0101m000) session. You can link a shop floor warehouse to a line station only if the following conditions are met:

- The **Use of Shop Floor Warehouses** check box in the Production Order Parameters (tisfc0100s000) session is selected.
- The **Station Type** field in the Stations - Line Segments (tiasl1551m000) session must be set to **Line Station**.

Time buckets

The size and number of buckets are determined by two factors:

- Your time bucket data. Refer to the help of the Bucket Definition (tiasl1100m000) session for more details. You can define buckets that become larger as you plan for a long time horizon. If you plan to make many changes to the assembly orders, you must define smaller buckets.
- The **Allocation Horizon** field in the Assembly Control Parameters (tiasc0100m000) session determines the total time for which you plan.

Note

You must define buckets for the entire **Allocation Horizon**. If you have an order that only partly falls within the time fence, allocation is not planned in Assembly Control.

Allocating assembly parts

In the case of **Line Station Based** transaction processing, allocation is performed per bucket, per line station. All the requirements by bucket and line station can be combined, which results in fewer transactions than would occur if every order were processed separately. The cumulative allocated assembly part requirements are logged in a clustered line station order (CLSO). The CLSO is communicated to Warehousing. You can view the cumulative allocated assembly part requirements in the Clustered Line Station Order - Assembly Part Requirements (tiasc7140m000) session.

To allocate assembly parts, complete these steps:

1. Select your main line in the Assembly Lines (tiasl1530m000) session and click **Assembly Part Requirements** on the appropriate menu.

2. Click **Build Assembly Part Allocations....** The Build Assembly Part Allocation (tiasc7240m000) session starts.

Refreshing and Freezing Assembly Orders

Use the Refresh and Freeze Assembly Orders (tiapl3203m000) session to update assembly orders in Assembly Control for product variants that are present in Assembly Planning. Optionally, the session can freeze assembly orders that fall within the freeze time fence.

You can start this session only if your current company is defined as master company in the Assembly Planning Parameters (tiapl0500m000) session.

The differences between the creation and the refresh of assembly orders can be summarized as follows: The planned offline date of the product variant is not evaluated against the assembly order time fence, but against the refresh time fence. The assembly order can be updated partly meaning that some segments only are updated. Line station orders (LSOs) that were frozen are not updated. LSOs that fall within the freeze time fence of the segments can be frozen after the line station orders are updated.

Assembly orders are refreshed only if the following criteria are met:

- The **AssemblyStatus** in the Product Variants (Assembly) (tiapl3500m000) session is **Planned**.
- The **To Be Deleted** check box in the details of the Product Variants (Assembly) (tiapl3500m000) session is cleared.
- The **Planned Offline Date** in the Product Variants (Assembly) (tiapl3500m000) session precedes the refresh time fence of the roll-off line. The refresh time fence is defined for each assembly line in the details of the Assembly Lines (tiasl1530m000) session.
- The **Assembly Line Structure Status** of the roll-off assembly line, which is displayed in the Assembly Lines (tiasl1530m000) session, is **Actualized**.
- The item has the following characteristics:
 - The item type is **Generic**.
 - The item is **Serialized**.
 - The item's item ordering data exists.
 - The item ordering system is **FAS**.

If you select the data in the current session by zooming to the related sessions, only those assembly lines, product variants, and generic items that meet these criteria can be selected. The time fences and planned offline date do not influence the selections you can make.

Refreshing an assembly order refreshes the LSOs. The current session can also freeze the LSOs, which means that changes in the order content are no longer automatically processed for these LSOs. Frozen LSOs can be changed manually only in Assembly Control. LSOs are frozen if the following conditions are met:

- The **Freeze** check box is selected.

- The line segment start date, which is determined when the assembly order is sequenced, falls within the freeze time fence of the line segment of the LSO. The freeze time fence is defined in the Line Segments (tiasl1540m000) session.
- The previous segments, that is, the segments closer to the start of the assembly line, are already frozen.
- The LSO is sequenced. Sequencing is carried out in Assembly Control for each assembly order. For each company a separate assembly order exists.

To understand the refresh process, you must understand the role of line-station variants (LSVs). Assembly orders are made up of LSOs. The actual order content of the LSOs is stored in LSVs. LSVs store the assembly parts and operations that are required for a specific line station. LSVs can be reused, which means that the LSV can be used for other assembly orders if these orders require the same assembly parts and operations on the line station concerned. This way, the LSVs reduce unnecessary data and enhance performance. Each LSV is identified by a unique code.

The refreshing of assembly orders can be outlined as follows:

1. Based on the selection of the product variants in the current session, the product variant structures are generated. Refer to the online help of the Generate Product Variant Structures (tiapl3210m000) session for a detailed explanation of this process. Note that the product variant structure is generated only if the **External Product Variant Structure** check box is cleared in the details of the Assembly Planning Parameters (tiapl0500m000) session. If this check box is selected, LN uses the current product variant structure.
2. Assembly order information is retrieved from Assembly Control. Line segments that are already frozen are not considered for the refresh of the assembly order. LSOs that are not sequenced cannot be frozen. For LSOs that are not frozen, the LSV codes must be retrieved.
3. The line structure is browsed, starting from the end of the roll-off line to the start of the supplying assembly line. While browsing the line structure, the assembly parts and operations that are related to an engineering module are determined. This information is used to gather information for the comparison and/or creation of LSVs. This information is taken from the flattened assembly parts and operations, and is evaluated based on effective dates and units. The required materials and operations are stored for each line station.
4. For each line station, a unique LSV code is calculated that identifies the required materials and operations for that line station. Then, LSV codes are compared with the codes of the LSVs that were already used by the LSOs. If, for a particular LSO, the LSV code that is just calculated differs from the code that was already present, an update is required. Something in the assembly parts and/or operations was changed.
5. The assembly orders are refreshed, which means that the LSOs are updated with new or other LSVs. If necessary, new LSVs are created and sent to Assembly Control; otherwise, existing LSVs are used.
6. If all LSOs on an assembly line were frozen, the **Frozen** check box, which appears in the Product Variant - Assembly Lines (tiapl3520m000) session, is selected. If all assembly orders for the product variant are frozen, the **AssemblyStatus** in the Product Variants (Assembly) (tiapl3500m000) session is set to **Frozen**.

After the assembly orders are refreshed and/or frozen, a completion report is created.

Click Make Job to add the current session to a job to run the session in batch mode.

To refresh and freeze assembly orders, complete these steps:

1. In the **Product Variant** selection range, select the product variant. Ensure that the **Freeze** check box is selected. Click **Refresh**.
2. Ensure that the status of line station orders is set to **Frozen**.

Starting and Completing Line Station Orders

If the line station order (LSO) has the status **Frozen** or **Ready to Start**, you can start the assembly order. When the order is started, the order is taken out of the buffer and is transferred to the first line station. The status of the LSO of the next line station is then **Ready to Start**. The start of an assembly order is the completion of the LSO that belongs to the buffer. Therefore, the status of the LSO is **Completed** at the point when the status of the LSO on the line station immediately after the buffer is **Ready to Start**. Both the start and completion of an assembly order can be initiated from the Line Station - Assembly Orders (tiasl6510m000) session or the Buffer - Assembly Orders (tiasl6520m000) session.

You can choose to either complete line station orders individually by assembly line, or complete multiple line station orders at once across multiple assembly lines; you can do the latter only if the assembly lines are located in the same logistic company.

You can report a line station order completed for each line station, the advantage is that this will ensure correct *actual time spent* reporting. The disadvantage of reporting a line station order completed for each line station is that the task can be time consuming.

If you complete line station orders individually, you must start with the buffer of the first line segment of the assembly line. To do this, use the Buffer - Assembly Orders (tiasl6520m000) session. After completion of the line station order on the buffer, you must continue to the line station following the buffer. To do this, use the Line Station - Assembly Orders (tiasl6510m000) session. At this line station, you complete the line station order and continue to the next station, which is either a buffer or a line station, and report it as complete. Follow this procedure until you have completed all subsequent buffers and line stations on the assembly line.

To complete multiple line-station orders simultaneously, you can select a line station order closer to the end of the assembly line and report it as complete. In this case, all previous line station orders on the assembly line and linked supplying lines are completed automatically. The advantage of this approach is that it saves time on individual line stations by reporting each line station order complete. The disadvantage of this approach is that on all line stations, the line station order will be reported as completed by setting the planned end time as the actual end time, which might not always reflect the *actual time spent* on the line station. You can also use bar-coding to complete the line-station order.

To complete the LSOs, carry out the steps below:

1. In both methods of completion, to complete the line station order, you must select the order in either the Line Station - Assembly Orders (tiasl6510m000) session or the Buffer - Assembly

Orders (tiasl6520m000) session, and click **Complete Line Station Order** from the appropriate menu.

2. After you complete the line station orders, LN sets the completed LSOs to the **Completed** status.

Receiving assembled items in inventory

Note

This section is applicable only when you store assembled end items.

Start the Assembly Orders (tiasc2502m000) session.

Select an assembly order. Click **Warehouse Order - Status Overview** on the appropriate menu. To receive the assembled item in inventory, complete the remaining activities.

You must generate a handling unit. The usage of handling units is mandatory for manufactured FAS items if the **Sell Multiples of Same Configuration** parameter is selected.

Handling units are used to link the received serials and specification to the following:

- To be shipped serials.
- Specification in the outbound procedure.

After you complete the activities, the status of the assembly order is set to **Completed**.

Checking inventory of assembled items

Start the Inventory 360 (whwmd4300m000) session.

Select the assembled item. Click **Warehouse Inventory** on the appropriate menu. The Warehouse - Item Inventory (whwmd2515m000) session starts. In this session, select the warehouse where the assembled item is stored. To verify that the correct configuration and quantity of the assembled item is on-hand and available, click **Inventory by Specification** on the appropriate menu. The Inventory by Specification (whwmd2519m000) session starts.

You can also start the Inventory by Specification (whwmd2519m000) session from the Production Item 360 (timfc1500m000) session.

The product variant holds the configuration details of the assembled item. For more information, refer to *Product variants in Warehousing* (p. 130).

Note

- To see the serial numbers related to the configured item in inventory in a specific warehouse, click **Inventory by Specification** on the appropriate menu. The Inventory by Specification (whwmd2519m000) session starts. In this session, click **Handling Units**. The Handling Units (whwmd5130m000) session starts. The Handling Units (whwmd5130m000) session displays all related handling units. The serial numbers are displayed on the handling unit.

- Another way to view your inventory by configured item is to use the Product Variants - Inventory (Assembly) (tiapl3600m000) session.

WIP transfers in the Assembly Control (ASC) module

WIP transfers consist of generating the transfer order, executing the issue, and executing the receipt. How these processes are performed, depends on the question whether the assembly lines between which the WIP is transferred, belong to the same company or not.

Single company

In a single-company situation, when the assembly lines are in the same company, these processes can be done manually, semiautomatically, or automatically. This parameter is defined on the Assembly Line in the Assembly Lines (tiasl1530m000) session.

The following chart illustrates how the process occurs for each parameter setting. For example, if you select Manual, the transfer order is generated by the execution of the Generate WIP Transfer (Trigger process 1). At the same moment, the warehouse order is unblocked, making the transfer issue possible. The execution of the WIP issue and the WIP receipt must be performed manually when the trigger is set for Manual or for Semi Automatic.

Description: The concept of process triggering holds that an event at a certain line station is used as a trigger to fire the execution of a session. Following is the description of triggers as mentioned in the table below:

- Trigger process 1 = Generate WIP Transfer.
- Trigger process 2 = Execute WIP Issue.
- Trigger process 3 = Execute WIP Receipt.

Parameter Setting	Manual	Semi Automatic	Automatic
Generate WIP Transfer	Executed by trigger proc. 1	Executed by trigger proc. 1	Executed by trigger proc. 1
Unblock warehouse order issue	Executed at same moment of trigger proc. 1	Executed by trigger proc. 2	Executed by trigger proc. 2
Execute WIP	Performed manually (WH)	Performed manually (WH)	Executed by Issue trigger proc. 2
Execute WIP	Performed manually (WH)	Performed manually (WH)	Executed by Receipt trigger proc. 3

Multicompany

In a multicompany situation, when the WIP is transferred between different companies, the WIP transfer is handled by means of intercompany sales and purchase orders. These orders are handled by Warehousing, which uses the multicompany functionality of the Enterprise Modeling Management. The EMM module also includes procedures for intercompany invoicing, document printing, and so on. The generation of these orders is triggered by the Generate WIP Transfer (tiasc7200m000) session.

Note

- A WIP transfer is always performed at the last line station of the current assembly line. You can generate the WIP transfer at an earlier station, but still the WIP transfer is actually performed at the last station. And only the Line Station Order (LSO) of the last line station registers the WIP transfer.
- In Assembly Control a WIP is always transferred between assembly lines and not between work centers. In this respect ASC differs from Job Shop Control, which can also transfer WIP between work centers.
- You can run the related sessions by means of the Process Trigger Definition (tiasl8100m000) session.

The following sessions are used for WIP transfers:

- Generate WIP Transfer (tiasc7200m000)
- Execute WIP Issue (tiasc7201m000)
- Execute WIP Receipt (tiasc7202m000)
- Line Station - Assembly Orders (tiasl6510m000)
- Assembly Lines (tiasl1530m000)
- Assembly Order - Line Station Orders (tiasc2510m000)

Executing WIP Transfer

Start **Manufacturing > Assembly Control > Stations > Line Station - Assembly Orders (tiasl6510m000)**.

When you execute WIP Transfer, LN transfers the value of the work in process between line stations on two different assembly lines.

To carry out the WIP transfer, complete the steps below.

1. Go to the last line station of your supplying assembly line.
2. Select the line station order related to your assembly order. Click **WIP Transfer** on the appropriate menu. Carry out the following appropriate > **WIP Transfer** commands in the correct sequence:
 - a. **WIP Transfer Generate**: On the last line station of the line segment on the supplying line.
 - b. **WIP Transfer Issue**
 - c. **WIP Transfer Receive**

Note

- If the **WIP Transfer Handling** parameter is set to **Automatic**, for our assembly lines (see Assembly Lines (tiasl1530m000)) you can carry out the **WIP Transfer Issue** and **WIP Transfer Receive** from Assembly Control.
- There is no batch session to handle all WIP transfers for your assembly orders. To avoid carrying out these WIP transfer steps for all assembly orders individually, we recommend that you model *process triggers* within the Assembly Control module. Use triggers to model a process trigger which automatically carries out these WIP transfers (**WIP Transfer Generate**, **WIP Transfer Issue**, and **WIP Transfer Receive**) based on a defined event.
For more information, refer to *Process Trigger Definition (tiasl8100m000)* (p. 127).

Backflushing Assembly Parts and Hours

If you do not want to record every issue of a material or every spent production hour individually, you can apply backflushing instead. Backflushing saves time, but some precision is lost. Typically, backflushing is used for low-cost material with a regular consumption. Backflushing does not reflect the physical material flow, but is an administrative process. Backflushing can be defined as the automatic issue of materials from inventory, or accounting for the hours spent on manufacturing an item, based on theoretical usage and the quantity of the item reported as complete.

For more information, refer to *Assembly backflushing* (p. 134).

To backflush the assembly parts and hours, complete these steps:

1. Select your assembly line. Click **Assembly Part Requirements > Backflush Requirements...** on the appropriate menu. The Backflush Requirements (tiasc7241m000) session starts.
2. Click **Backflush** to start the backflushing process.
3. When the backflushing process is successful, LN sets all the line station orders related to assembly orders to the **Closed** status. The assembly orders have the **Completed** status.

Closing assembly orders

- **Prerequisites**

You can close assembly orders only if the following conditions are met:

- The status of the assembly orders must be **Completed**.
- All line station orders that are linked to the assembly orders must have the status **Closed**, that is, these line station orders must have been backflushed. Refer to the Backflush Requirements (tiasc7241m000) session.

- **Functionality**

Closing an assembly order has the following consequences, unless specified otherwise:

- Assembly orders on supplying lines are also closed.
- If you use **Order Based** transaction processing, the Assembly Orders (tiasc2502m000) session also closes the clustered line station orders of the specified assembly orders. This action results in the calculation of the results and creation of the financial transactions that are mentioned in the online help of the Close Assembly Lines (tiasc7220m000) session.
- If the assembly order that is closed is the roll-off line assembly order, the product variant status in Line Assembly Configuration (LAC) is set to **Completed**.
- LN creates the financial transactions for the closed assembly orders. LN produces error messages if the financial transactions cannot be completed. Click the **Messages** button to see the error messages.
- The item surcharges are posted, and the additional calculation office variant is calculated and posted.

- **Financial transactions**

The additional calculation office variant is calculated as follows:

$$\text{Additional calculation office variant} = \text{estimated WIP} + \text{item receipt surcharges} - \text{option-based standard cost.}$$

In this calculation, the option-based standard cost is calculated and retrieved from Line Assembly Configuration (LAC).

The following financial transactions are posted when the additional calculation office variant is calculated and posted:

- Transaction origin: ASC production.
- Financial int. transaction: Additional calculation office variant.

Debit	Additional calculation office variant
Credit	Production WIP

- Transaction origin: ASC production.
- Financial int. transaction: Item surcharge (receipt).

Debit	Production WIP
Credit	Absorption surcharge

Note

- If you use **Line Station Based** transaction processing, clustered line station orders are closed by the Close Assembly Lines (tiasc7220m000) session.
- If you use **Order Based** transaction processing, you can reopen **Closed** assembly orders, that is, change the status to **Completed**, by booking extra hours to the orders in the People package.

To close assembly orders, complete these steps:

1. Select assembly orders and click **Close Assembly Orders...** on the appropriate menu. The Close Assembly Orders (tiasc7210m000) session starts. Select assembly orders in the **Selection Range** and click **Close Orders**.
2. If the process to close assembly orders is successful, LN sets all your assembly orders to the **Closed** status.

Closing assembly lines

- **Prerequisites**

You can close assembly lines by using this session only if the following conditions are met:

- You use **Line Station Based** transaction processing. The **Transaction Processing** parameter is set in the Assembly Control Parameters (tiasc0100m000) session. If you use **Order Based** transaction processing, you cannot use this session because LN closes the line automatically when the assembly orders are closed in the Close Assembly Orders (tiasc7210m000) session.
- All line station orders are **Closed**, which means that all line station orders for this day are backflushed.

- **Functionality**

If you close an assembly line, the following actions are performed:

- The line surcharges are applied to the actual WIP. This action happens before the production results are calculated.
- The results of the line are calculated and posted.
- The clustered line station orders (CLSOs) that are linked to the line stations receive the status **Closed**. In **Line Station Based** transaction processing, a CLSO is linked to a line station per day, and this CLSO holds all the parts requirements.

- **Post-requirements**

After this session is run, you must delete unwanted data with the Purge State-dependent ASC Data (tiasl1200m000) and Purge State-independent ASC Data (tiasl1210m000) sessions.

- **Financial transactions**

The production result is calculated as follows:

$$\text{Production result} = \text{estimated WIP} - \text{actual WIP}$$

The financial transactions that are posted depend on whether the assembly line concerned is a main line or supplying line.

If the assembly line is a *supplying* line, the following transactions are posted:

- Transaction origin: ASC production
- Financial int. transaction: Line surcharges

Debit	Production WIP
Credit	Surcharge coverage

- Transaction origin: ASC production
- Financial int. transaction: Production result

Debit	Production WIP
Credit	Production result

If the assembly line is a *main* line, the WIP of every order is transferred to the calculation office of the order, which results in the posting of a WIP transfer issue and receipt. In addition to the postings provided in the previous paragraphs, the following transactions are also posted:

- Transaction origin: ASC production
- Financial int. transaction: WIP transfer issue

Debit	WIP in transit
Credit	Production WIP

- Transaction origin: ASC production
- Financial int. transaction: WIP transfer receipt

Debit	Production WIP
Credit	WIP in transit

Note

- If you use **Line Station Based** transaction processing, you can only have results per assembly line per day. If you run this session for a range of days, that is, for every day that the line surcharges are applied to the actual WIP of that day, the production results are calculated and posted for each day. The final outcome is a result that is calculated per assembly line per day, and is logged to the last line station of the assembly line. Line surcharges are applied to the actual WIP before the production results are calculated.
- The WIP figures apply to all the line stations of all the orders on the day concerned.
- You can reopen an assembly line by booking extra hours in People. You must then close the assembly line by using the Close Assembly Lines (tiasc7220m000) session.

You must perform backflushing successfully before the assembly lines can be closed.

To close assembly lines, complete the steps below.

1. Select the main assembly line and click **Close...** on the appropriate menu. The Close Assembly Lines (tiasc7220m000) session starts. Select **Close Lines** on the appropriate menu.
2. If the process to close the assembly lines is successful, all Clustered Line Station Orders (tiasc7530m000) must have the **Closed** status.

Post-assembly operations

Sometimes, an assembled item that comes off the assembly line needs additional work. In LN, you can accomplish this by creating a rework order for the item. You can execute additional operation in regular work centers on an item after completion of an assembly order at a later date.

Procedure

To perform additional job shop operations on an item after completion of the assembly order:

1. Set the generic item up with an associated standard item.
2. Optionally, define a routing for the standard item.
3. In the Production Orders (tisfc0501m000) session, create a production order. In the appropriate menu, click **Serial Numbers** and enter the end item's serial number.
In the details session, select the **Rework Order** check box.
4. Define the production order's operations. You can select a routing for the production order or manually add operations to the production order.
5. Use the Estimated Materials (ticst0101m000) session to define any required materials. To add the materials from another item's bill of material (BOM), on the appropriate menu, click Show Subassembly.

Note

The manufactured item that is the end item of the rework order is also a material for that rework order.

Processing Sales Order Line

Start **Sales > Sales Orders > Sales Orders > Sales Orders (tdsls4100m000)**.

After sales orders are created, sales order approval is a mandatory step in the sales order procedure. The execution of the order procedure activities can start when a user approves the order, either in the Approve Sales Orders (tdsls4211m000) session, or by clicking **Approve** on the appropriate menu of the Sales Orders (tdsls4100m000) session or the Sales Order (tdsls4100m900) session. The approval of the sales order also triggers the sales order line execution if all activities on the order type are set to *automatic*.

For more information on scenarios where assembled end items are sold and put on stock first, before being shipped through a sales order, refer to *Product variants in Warehousing (p. 130)*.

Note

If you send the item to the customer immediately upon completion of the assembly order, you only need the generic item. If a generic item has an associated standard item, you can still enter the generic item on a sales order line. If you enter the generic item on a sales order line, LN sets the **Delivery Type** field on the sales order line to **Work Center** and you cannot store the finished item in inventory.

Unit effectivity in EDM

To set up and use unit effectivity in Engineering Data Management you must use the Unit Effectivity module in Common. To set up data, refer to *To set up unit effectivity (p. 108)*.

To use unit effectivity when engineering an item, carry out the following steps:

1. Define the engineering bill of material (EBOM) in the Engineering BOM (tiedm1110m000) session. To link exceptions to a BOM line, select the BOM line and click **Exceptions** from the appropriate menu. The Exceptions (tcuef0105m000) session is started. If the end item is already defined, you can use effectivity units of the end item. Otherwise, use effectivity units of engineering items.
2. The purpose of exceptions in an EBOM is to engineer a generic design. This means that when the design is finished, all exceptions must be copied to the production BOM. Use the **Copy Engineering BOM** session to copy the EBOM and its linked exceptions to the PBOM. During the copy process, LN provides the user with the possibility to replace the engineering item in the item – effectivity series with a general end item. To do so, LN starts the Relink Item - Effectivity Series (tcuef0201m000) session.
3. At a certain point of time, a general end item must be defined. This is the item that is used on the sales order line. For reasons of clearness, you must link the item – effectivity series that is still linked to the engineering item to the end item. Use the Relink Item - Effectivity Series (tcuef0201m000) session to relink the effectivity series from the engineering item to the end item. You can start this session from the appropriate menu in the Items - Effectivity Series (tcuef0101m000) session.

Finalizing Engineering Data

If you copy an E-BOM to a PBOM by using the Finalize Engineering Data (tiedm3240m000) session, LN proceeds as follows. If the **Unit Effective Supply** check box in the Items (tcibd0501m000) session is selected for the end item, LN does not copy the effectivity statements.

To set up unit effectivity

To set up data for unit effectivity, carry out the following steps:

1. Select the **Unit Effectivity** check box in the Implemented Software Components (tccom0500m000) details session.
2. Select or clear the **Generate Effectivity Unit during Demand Entry** check box in the Unit Effectivity Parameters (tcuef0500m000) session.
 - If this check box is selected, and also the **Unit Effective End Item** check box is selected in the Items (tcibd0501m000) session, an effectivity unit is *automatically* generated when you create a new sales quotation line, sales order line, or sales contract line for a unit effective item. Otherwise, you can enter an effectivity unit yourself. The effectivity unit can be used for pegging purposes. If desired, you can click **Requirements** on the order line to select requirements to model the item. Unit effectivity is then used as a lean configurator. The effectivity unit is linked to a series that is defined in the **Default Series** field.
 - If the **Generate Effectivity Unit during Demand Entry** check box is cleared, and you create a new sales order line, sales quotation line, or sales contract line for a unit effective item, the effectivity unit is by default 0 (zero). Only if you click **Requirements**, an effectivity unit is created, after which you can select requirements to model the unit effective item.
3. For engineering items, you can use the **Unit Effective End Item** check box in the Engineering Item (tiedm0110m000) session so that an effectivity unit is *automatically* generated if you create a new sales quotation line, sales order line, or sales contract line for a unit effective item. If required, you can select the **Interchangeable** check box.
4. Specify business requirement codes and descriptions in the Requirements (tcuef0106m000) session. You use requirements later on to:
 - Link them to exceptions during the design of, for example, a BOM or a routing (series approach).
 - Select them if you enter an effectivity unit in the sales order line (sales order approach). This eventually results in production orders that use the exceptions defined for the requirements.For every requirement, you can define an upgrade price. The upgrade prices are part of the effectivity unit's sales price.
5. If desired, you can define default requirements for end items in the Item - Requirements (tcuef0108m000) session. You can import those default requirements in the Requirement - Effectivity Units (tcuef0107m000) session if an effectivity unit is defined for the end item.

How to continue

Now that you have set up unit effectivity, you can use it in the way you defined it in step 2.

For more information, refer to:

- Unit effectivity as a lean configurator in Sales
- To configure effectivity units

Procuring configured items in Assembly Control - Master Data Setup

This topic explains the master data set up required to procure configured items in Assembly Control module. You can use the configurable purchased items in Assembly Control module only.

To procure configured items, you must:

- Select the **Configurable** check box in the Items (tcibd0501m000) session. If this check box is selected, the item is a configurable item. You can use the configurable purchase items to procure sub-assemblies that are required on the assembly line.
- Select the **Purchase Schedule in use** check box in the Items - Purchase (tdipu0101m000) session. You can use only purchase schedules to procure the configured items in Assembly Control module.
- Select the **Order Controlled/SILS** option in the **Supply System** field in the Item Data by Warehouse (whwmd2110s000).
- Clear the **Supply from Warehouse** check box in the Item Data by Warehouse (whwmd2110s000) session.
- Select the **Sell Multiples of Same Configuration** check box in the Assembly Planning Parameters (tiapl0100s000) session. For more information, refer to *Selling multiples of product variants for assembly* (p. 35).

Note

You must specify the following for the configured end item, in the Items (tcibd0501m000) session:

- Set the **Item Type** to **Manufactured** or **Product**.
- Set the **Default Supply Source** to **Assembly**.

However, you can still specify the configured end item as **Generic** with the following limitations:

- You cannot store a generic item in inventory.

- You can create a sales order for a generic item with the quantity required as one only.

Procuring configured items in Assembly Control - BOM setup

This topic explains the product structure model that must be used when you procure configured items in Assembly Control module.

Generic BOM - PCF

In the PCF module, the generic BOM can be defined for any configurable item using the Configurable Item - Structure (tipcf3100m100) session or the Generic BOMs (tipcf3110m000) session. An item is configurable when the **Configurable** check box is selected. You can select the **Configurable** check box in the Items (tcibd0501m000) session.

A manufactured or generic assembly items can hold the following components:

- Manufactured or Generic Assembly Items
- Engineering Modules
- Purchased Configurable Items

Note

For purchased configurable items, you can specify a quantity greater than 1 on the BOM line.

The link between the BOM line for a purchased configurable item and the Assembly Control is maintained by means of the following fields in the Generic BOMs (tipcf3110m000) session:

- **Operation**
- **Line Station**

Note

You can use the purchased configurable item in Assembly Control module only.

You can use a configurable item to create an item structure that can hold a configurable purchased sub-assembly. The purchased sub-assembly is issued at the assembly line like other assembly parts.

Product structure for procuring configured items in Assembly Control module:

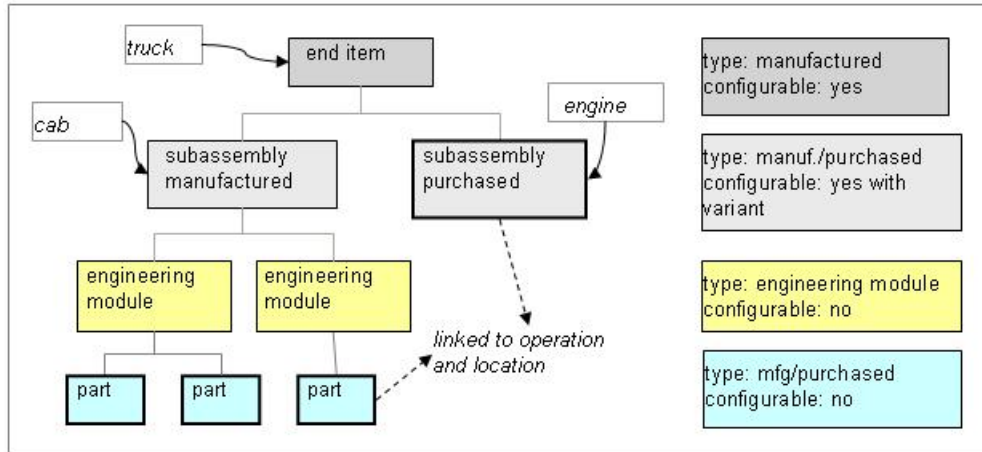

Legend

cab cabin

To model the purchased parts:

- Model the standard purchased items as part of an Engineering Module, using the Generic Bill of Material (tiapl2510m000) session.
- Model the configurable purchased items, using the Configurable Item - Structure (tipcf3100m100) session or the Generic BOMs (tipcf3110m000) session.

The purchased items must be defined at the lowest level in the generic BOM structure, because you cannot define a BOM for the purchased items in LN.

To link features to configurable items, you can use the Product Features by Configurable Item (tipcf1101m000) session. You can link the constraints to the features or to the BOM line.

Note

- The main configured end item can be manufactured or generic with the **Default Supply Source** being **Assembly**. The child item can be a configurable purchase item.
- The main item cannot be a configurable purchased item.

Product Variant Structure

In a product variant structure, a manufactured assembly end item can hold a purchased configurable item.

To use the purchased configured components, you must select the **Sell Multiples of Same Configuration** check box in the Assembly Planning Parameters (tiapl0100s000) session. As a result, the product variant

number is populated in the item specifications. This number in the specifications is used to identify the product variant in the transactions.

The link between the product variant structure and the Assembly Control is maintained by means of the following fields in the Product Variant Structure (tiapl3110s000) session:

- **Operation**
- **Assembly Line**
- **Line Segment**
- **Line Station**

Product variants - Purchased configurable items

This topic explains the following functionality that pertains to purchased configurable items:

- Compare any configured item of the variant.
- Define product variant purchase price structure.

Compare variants

You can compare two product variants to check the following:

- The inventory of a configured purchased subassembly.
- The possibility of using inventory of a matching configuration rather than order a new configured item.

Note

You can consider two configured items as interchangeable if all the options are the same.

You can compare the following configured items of a product variant:

- The configured end item
- Any configurable child

To compare the configured items of a product variant, you can use the Option List ID. The configurable items are compared at the option set level. Two configured items that are created by a variant are considered as interchangeable if they have the same Option List ID.

The Option List ID is used for the following types of transactions:

- Manufactured assembly item transactions
- Purchased configured item transactions
- Inventory transactions

Variant numbers and Option list IDs

The matching of demand and supply of purchased configurable items is based on the Option List ID.

The matching of the demand and supply of a manufactured assembly end item is based on the product variant. Example the demand for the manufactured assembly end item is generated when a product variant is created for a new sales order. The Option List ID for this variant matches with a redundant variant which is in stock. An assembly order is created to meet this demand is created as the variant numbers differ.

The variants numbers and Option List IDs are used in the following processes:

- Create assembly planning (Calculate Assembly Part Requirements (tiapl2221m000)
- Generate assembly orders
- Generate warehouse outbound advice.

Product variant purchase price structure

You can set up the purchase price for a configured item. The purchase price depends on the options of a configured item. You can calculate the purchase price of a variant during the configuration process. You can do so, after you calculate the sales price. If you update the variant, you are prompted to re-calculate the sales price.

To re-calculate the sales price, the configuration date is used as the reference date for price list validation. You can set the configuration date in the Sales Parameters (tdsls0500m000) session in the Sales package. The **Configuration Date (PCS)** can be:

- **Order Date**
- **System Date**
- **Delivery Date**

To calculate the purchase price for a set of variants, you can use the Calculate Product Variant Purchase Price Structure (tipcf5235m000)

To calculate the purchase price for the current variant, you can use the following sessions:

- Product Variants (tipcf5501m000)
- Product Variant Purchase Price Structure (tipcf5535m000)

The purchase price for the schedule is retrieved from the Generic Price Lists (tipcf4101m000) session and is based on the value selected in the **Purchase Price Date Type** field in the Pricing Parameters (tdpcg0100m000) session. Allowed values

- **Order Date**
- **System Date**
- **Delivery Date**

Important!

The purchase price structure is used for analysis only.

Note

Since different dates are used as reference date for sales price/purchase price calculation, the price on the schedule can differ from the price displayed in the variant data.

This chapter comprises of the topics that explain various concepts in Assembly Control module.

Assembly Control

Use the Assembly Control module to schedule and control assembly orders. Assembly Control is intended for use by companies that produce many variants of complex products in a flow assembly line, although it can also be used in low-volume assembly environments if order-specific transaction handling is used.

System performance is enhanced, and the data storage capacity is reduced through the use of:

- **Line-station based transaction handling**
Transactions are performed by period.
- **Line-station variants**
Orders are stored by common variants rather than individually.
- **Eliminating floor stock from order content**
Floor stock can be included in the work instructions, but it is not backflushed.

The functionality of Assembly Control can be roughly divided into four sections:

- **Scheduling**
The assembly orders can be remixed and scheduled by Assembly Control.
- **Dispatching**
Material requirements are dispatched to the job shop or to a supplier, and work instructions can be printed. Many of these processes are run by process triggers.
- **Monitoring**
Events are reported to LN in order to continue the assembly process using real-time activities.
- **Costing**
Most of the financial calculations are performed outside the scope of Assembly Control. Cost components can be defined on either a detailed or aggregated level, or a combination of the two.

Performance aspects

The settings in this session could affect system performance and database growth. For more information, refer to Delete in Assembly Control.

Delete Assembly Orders

You can delete the assembly orders for which the work has not started yet. The assembly orders that you want to delete must not be frozen which implies that none of the related line station orders are frozen.

You can delete the assembly orders from the following sessions:

- Assembly Line - Line Mix (tiasc2501m000): appropriate > **Delete Assembly Orders**
- Assembly Orders (tiasc2502m000): appropriate > **Delete Assembly Orders**

Important!

Deletion of assembly orders - Required conditions

The assembly order must be in the **Created** or **Sequenced** status and

- None of its related line station orders are frozen.
- No supply messages for assembly parts are already generated and transferred to Warehousing or Order Management.

Assembly order deletion-Important Points

- The deletion of an assembly order can only be initiated from the main assembly line also known as the roll-off line. In case of a multicompany assembly model, when you delete the assembly order on the main line, the related assembly orders on the supplying assembly lines are also deleted provided all related assembly orders on the supplying lines fulfill the conditions specified above. If one of the linked assembly orders on supplying lines cannot be deleted, the assembly order on the main line cannot be deleted either.
- The deletion of an assembly order is not allowed if the assembly order or one of its linked supplying assembly order is blocked. A message is displayed to inform the user about the order that has a blocking reason that must be resolved first before the assembly order can be deleted.
- The deletion of an assembly order means that the assembly order including its contents (operations, material requirements and so on) is deleted from the system. The assembly part requirements (part allocation) are updated accordingly.
- The deletion of an assembly order results in its removal from the line mix and line segment sequence. This means that the position of the deleted assembly order is made available again for line mixing and sequencing.

You must (re)generate line mix and/or use sequencing engine to also reflect the changes in the line mix and line segment sequence.

- The deletion of an assembly order results in the update of line utilization to reflect the new line utilization.
- The deletion of an assembly order that has the **Sequenced** status results in the item serial inventory being set to 0 as the item on an assembly order is always serialized.

Assembly items

An assembly item is an item with default source **Assembly**. You specify an item's default source in the **Default Supply Source** field in the Items (tcibd0501m000) session.

Restrictions

The following rules and restrictions apply to assembly items:

- An item cannot be both a revision-controlled item and an assembly item.
- An assembly item must be a serialized item.
- An item with item type **Engineering Module** is always an assembly item.
- A project item cannot be an assembly item.
- An assembly item cannot be used as subassembly for subcontracting.

Item types **Generic, Manufactured and Product**

To support storing an assembly item in inventory, you can represent one physical item by a pair of two items in LN:

- **An item with item type Generic**
You use this item code on the assembly order in Assembly Control.
- **An item with item type Manufactured or Product**
You can use this item code on sales order lines and on warehousing orders to record item inventory.

Note

If you deliver the finished generic item to the customer without storing it in inventory, you do not need an item with item type **Manufactured** or **Product**.

Alternatively, you can configure product variants that contain purchased configurable items. You can use a configurable item to create a item structure that can hold a configurable purchased sub-assembly. You can store the end item in Warehousing and perform inventory transactions.

For more information on procuring purchased configurable items in Assembly Control module, refer to

- *Procuring configured items in Assembly Control - Master Data Setup (p. 109)*
- *Procuring configured items in Assembly Control - BOM setup (p. 110)*
- *Product variants - Purchased configurable items (p. 112)*

Assembly items and FAS items

A **FAS item** is a **Generic**, **Manufactured** or **Product** item with the FAS (Final Assembly Scheduling) order system. FAS items are produced in a mixed model flow process on an assembly line.

If you set the **Default Supply Source** field in the Items (tcibd0501m000) details session to **Assembly**, LN automatically sets the **Order System** field in the Items (tcibd0501m000) session to **FAS**. You can also specify the order system by warehouse-item combination in the Item Data by Warehouse (whwmd2510m000) session.

An assembly item must have order system **FAS**.

Assembly Order Costing

Costing is a crucial aspect of the *Assembly Control (p. 115)* module. The manner in which costing is performed depends partially on how you define your cost components. Other aspects of costing that are described here are:

- Transaction-processing methods
- WIP transfers
- Calculation of final results
- Differences between Assembly Control module costing and Job Shop Control (JSC) module costing.
- Where to view financial data in the Assembly Control module.

Note

The aspects of financial costing that are described here have no relation to the theoretical, mathematical costs associated with line sequencing.

- **Cost components**

There are four types of cost components:

- Materials
- Operations
- Surcharges
- General Costs

Cost components must be posted on the aggregated and collect levels of the cost scheme, the detailed level is optional.

- **Transaction-processing methods**

The Assembly Control module is intended for use by companies that produce many variants of complex products in a flow-assembly line. Assembly Control can also be used for low-volume assembly if you select **Order Based** transaction processing. Select your transaction-processing method in the **Transaction Processing** field in the Assembly Control Parameters (tiasc0100m000) session.

- Use **Line Station Based** transaction processing when you do not need to trace back to the original assembly order. Costs are posted to the assembly line. Results are calculated by period by assembly line.
- Use **Order Based** transaction processing when you want your costing performed on the basis of individual assembly orders. Costs are posted by order by assembly line. Results are calculated by order by assembly line.

- **WIP transfers**

WIP transfers consist of:

- **Generating the transfer order**

A WIP transfer generates a transfer order. However, if the transfer occurs between line stations that are in different logistical companies, a sales order and a purchase order are generated.

- **Performing the material issue**

A WIP issue may unblock or immediately process the transfer warehousing order, dependent on your parameter settings. In multicompany situations, the normal sales procedure must be followed in order to ship the goods.

- **Performing the receipt**

A WIP receipt acknowledges the receipt of the WIP transfer order at a main assembly line that has received work from a supplying assembly line. Warehousing processes the inbound line automatically. If the assembly lines are from two different logistical companies, it is necessary to use sales orders and purchase orders (rather than WIP transfer orders). In multicompany situations, the normal receipt procedure must be followed in order to receive the goods.

You can select whether you want these processes to occur automatically, semiautomatically, or manually.

- **Calculation of financial results**

When you close an assembly line with the Close Assembly Lines (tiasc7220m000) session, the production results of the line are calculated. All the line station orders must have the status **Closed**. The financial results are the WIP transactions (which are estimated costs) minus the actual costs.

Differences between costing in Job Shop Control and Assembly Control

- In Assembly Control, the quantity completed is always one.
- There is no scrap and yield in Assembly Control.

- WIP transfers are only created between different assembly lines, and not between line stations (of the same line).
- There is no set-up time in Assembly Control.
- End item unit costs (estimated material costs and hours costs for an order) are not calculated for an assembly order. This is not necessary because each end item uses the same assembly line, so there is no point in creating separate surcharges for each item.
- In case of **Line Station Based** transaction processing, variances are calculated for an assembly order and not for a generic item.
- Production results are not split into price variances and efficiency variances in Assembly Control.
- Financial results in Assembly Control are posted to the cost component of the assembly line.

Where to view financial data in Assembly Control

- Financial Transactions (tiasc7510m000)
- Print Financial Transactions (tiasc7410m000)
- Print Financial Transactions by Assembly Line (tiasc7414m000)
- Print Costing by Assembly Order or Assembly Line (tiasc7411m000)

Procuring configured items in Assembly Control - BOM setup

This topic explains the product structure model that must be used when you procure configured items in Assembly Control module.

Generic BOM - PCF

In the PCF module, the generic BOM can be defined for any configurable item using the Configurable Item - Structure (tipcf3100m100) session or the Generic BOMs (tipcf3110m000) session. An item is configurable when the **Configurable** check box is selected. You can select the **Configurable** check box in the Items (tcibd0501m000) session.

A manufactured or generic assembly items can hold the following components:

- Manufactured or Generic Assembly Items
- Engineering Modules
- Purchased Configurable Items

Note

For purchased configurable items, you can specify a quantity greater than 1 on the BOM line.

The link between the BOM line for a purchased configurable item and the Assembly Control is maintained by means of the following fields in the Generic BOMs (tipcf3110m000) session:

- **Operation**
- **Line Station**

Note

You can use the purchased configurable item in Assembly Control module only.

You can use a configurable item to create an item structure that can hold a configurable purchased sub-assembly. The purchased sub-assembly is issued at the assembly line like other assembly parts.

Product structure for procuring configured items in Assembly Control module:

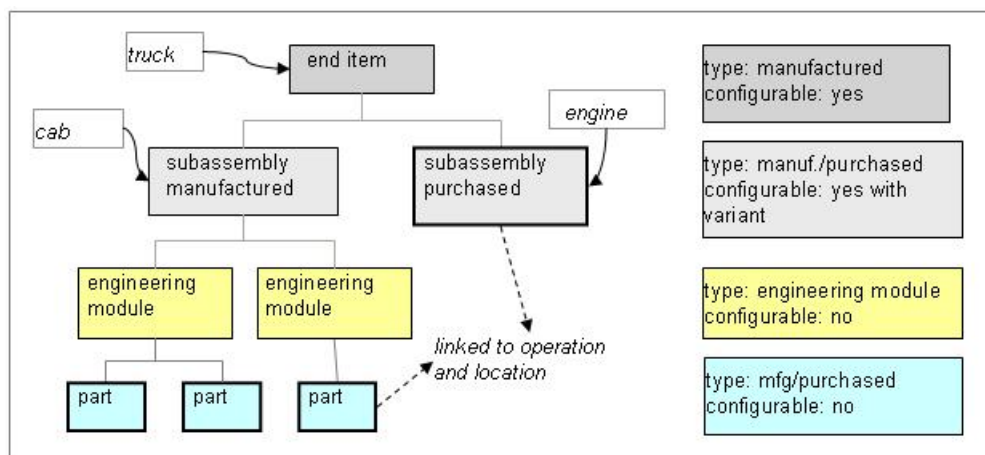

Legend

cab cabin

To model the purchased parts:

- Model the standard purchased items as part of an Engineering Module, using the Generic Bill of Material (tiapl2510m000) session.
- Model the configurable purchased items , using the Configurable Item - Structure (tipcf3100m100) session or the Generic BOMs (tipcf3110m000) session.

The purchased items must be defined at the lowest level in the generic BOM structure, because you cannot define a BOM for the purchased items in LN.

To link features to configurable items, you can use the Product Features by Configurable Item (tipcf1101m000) session. You can link the constraints to the features or to the BOM line.

Note

- The main configured end item can be manufactured or generic with the **Default Supply Source** being **Assembly**. The child item can be a configurable purchase item.
- The main item cannot be a configurable purchased item.

Product Variant Structure

In a product variant structure, a manufactured assembly end item can hold a purchased configurable item.

To use the purchased configured components, you must select the **Sell Multiples of Same Configuration** check box in the Assembly Planning Parameters (tiapl0100s000) session. As a result, the product variant number is populated in the item specifications. This number in the specifications is used to identify the product variant in the transactions.

The link between the product variant structure and the Assembly Control is maintained by means of the following fields in the Product Variant Structure (tiapl3110s000) session:

- **Operation**
- **Assembly Line**
- **Line Segment**
- **Line Station**

Product Configuration (PCF)

In a traditional production control system, the product structure generally consists of:

- Item data, such as delivery time and standard cost.
- Data that relates to the structure of items, such as bills of material.
- Data about operations, such as routings.

This system may be adequate for companies that produce a limited number of products. However, if a large number of variants of the finished products are produced, they are usually only assembled or manufactured when the customer's order has been received. In such cases, the traditional information system may encounter problems with the quantity, complexity, and manageability of the product data, and the need for timely availability of the information.

Almost any company that assembles to order deals with product variants, which makes it impossible to define the product structure for all the versions of all finished products in advance. The answer to this problem is configuration management. This can be translated into a well conceived, modular, product design with proper validation and design support functions provided by the information system to enhance the level of logistical control.

In the *Product Configuration (PCF)* (p. 122) module, a product model is created that defines all the features of the product model. You can define the desired product variant if you select the options of the features.

The translation of your requirements into the product structure of the variant is controlled by a set of decision rules and constraints. These constraints indicate the components and operations that are or are not used in a specific version.

Performance aspects

The settings in this session could affect system performance and database growth. For more information, refer to PCF without PCS.

PCF procedures

Refer to the following online manual topics for more information on specific PCF subjects:

General

- Configurator
- *How to define a product model (p. 125)*
- How to test the product model
- How to configure product variants and generate product structures
- How to use a product model in a sales quotation
- How to use a product model in a sales order

Financial

- How to calculate a discount percentage on the basis of the sales price
- How ERP calculates the product variant cost structure
- How to test the price list

Parameter sessions

Parameters are variables to which a constant value is assigned. By setting parameters, you can tailor the functioning of the module to company specific requirements.

Initially, the parameters are set to defaults by running the Initialize Parameters (tcmcs0295m000) session. You can then change these settings in the parameter session.

Store finished generic items

This topic describes how to set up the items to be able to store the finished end product of an assembly order in inventory.

Setup

To be able to store a finished generic item in inventory, you must define *two* items: a generic item and a standard item.

Both items represent the same physical item. In Assembly Control, you use the generic item. In Sales Control and Warehousing, you use the associated standard item.

To specify which standard item is associated with the generic item, use the Configurable Item - Assembly Line (tiapl2500m000) session.

Item settings

For the generic item and the standard item, use the following item settings:

Session	Field	Generic item	Standard item
Items (tcibd0501m000)	Item Type	Generic	Manufactured or Product
Items (tcibd0501m000)	Serialized	Yes	Yes
Items (tcibd0501m000)	Revision Controlled	(Not used)	No
Items (tcibd0501m000)	Order System	FAS	FAS
Items - Warehousing (whwmd4500m000)	Serials in Inventory	(Not applicable)	Yes
Items - Warehousing (whwmd4500m000)	Lots in Inventory	(Not applicable)	(See below)

The reason why the **Serials in Inventory** check box must be selected, is that Warehousing would otherwise not be able to distinguish between product variants.

Additional instructions:

- The generic item and the standard item must have the same inventory unit.
- If you use unit effectivity, you must define both items as unit effective items in the Items (tcibd0501m000) session.
- If the standard item is lot controlled, you must use the lot-in-inventory type of lot control. To make an item lot controlled, select the **Lot Controlled** check box in the Items (tcibd0501m000) session. To use the lot-in-inventory type of lot control, select the **Lots in Inventory** check box in the Items - Warehousing (whwmd4500m000) session.

Standard cost calculation of the standard item

The standard item must have an effective cost component structure. The standard inventory valuation functionality for items in inventory requires such a cost component structure.

To specify the inventory valuation method, in the Item Data by Warehouse (whwmd2510m000) session, select a value in the **Inventory Valuation Method** field.

To obtain the most accurate inventory valuation, select an inventory valuation method based on actual costing. The recommended inventory valuation method is **Serial Price (Serial)**.

If the inventory valuation method is **Standard Cost**, which is not an actual costing method, you must calculate a standard cost in the Standard Cost Calculation module. In this case, LN values the item against the calculated fixed transfer price (FTP) of the standard item and ignores differences between the product variants.

How to define a product model

Carry out the following steps to define a product model:

Step 1: Product Configuration Parameters

In the Product Configuration Parameters (tipcf0100m000) session, determine the version of the product configurator. If the product model is in the creation stage, you must use the interpreter version. The advantage of this version is that the generic product model can be tested immediately if new constraints are created. If changes are made to these constraints, the constraints need not be recompiled first. Refer to the **Product Configurator Version** field in the Product Configuration Parameters (tipcf0100m000) session.

Step 2: Items - General

In the Items (tcibd0501m000) session, enter the generic items that you need for the product model. If the item is a generic item, the following characters are not allowed in the item code:

% ' " ^ \ ! @ # \$ & * () | / ; ~ ` ? { } [] < >

The reason is that object files that are generated for constraints in the Product Configuration module cannot contain these characters.

You must decide whether you want to use a PCS budget and/or a PCS project when producing product variants, or you want to use PCF without PCS. A PCS budget is used to calculate the standard cost. A PCS project is used to plan, produce, and control the manufacturing process. Consequently, the structure of the product variant is generated by budget or project. The advantage of using PCS is that it provides an item with a detailed cost roll-up, and the possibility of pegging. However, in high volume environments, a detailed cost roll-up is often not necessary. Furthermore, using PCS requires extra time to calculate the project costs and to delete the project structure afterwards.

- If you want to use Project Control (PCS) for Product Configuration (PCF), the **Customize** check box must be selected in the Items (tcibd0501m000) session.
- If you want to use Product Configuration (PCF) without Project Control (PCS), the **Customize** check box must be cleared in the Items (tcibd0501m000) session.

If you configure items without PCS projects, standard items are generated instead of customized items. Pegging functionality is secured by the unique item codes of the configured items that can be related back to the sales order.

Step 3: Product Features

In the Product Feature (tipcf0150m000) session, enter the required product features. You must define all required product features with possible options in this session.

Step 4: Product Features by Generic Item and Constraints by Generic Item

In the Product Features by Configurable Item (tipcf1101m000) session, the product features are linked to a generic item. Product features are controlled by constraints, which you can define in the Configurable Item - Constraints (tipcf2110m000) session.

Step 5: Generic BOMs and Generic Routing

In the Generic BOMs (tipcf3110m000) session and the Generic Routing (tipcf3120m000) session, you can enter respectively the product structure and the routing. The constraints in step 4 are used to ensure that the product structure and routing are in accordance with the selected options.

Step 6: Price-List Matrix Codes, Price-List Matrices and Generic Price Lists

The Price List Matrix Codes (tipcf4110s000) session, the Price List Matrices (tipcf4120m000) session, and the Generic Price Lists (tipcf4101m000) session are not mandatory. If a sales price or a purchase price for a generic purchase item must be generated, the price list can be used to define a price list. You can use matrices for different features that have mutual relationships associated to the price. By defining the price list code and the price list matrices, the features and values in the matrices can be entered.

Step 7: Settings for Generic Item-Data Generation

The Generic Item - Settings for Data Generation (tipcf3101m000) session is not mandatory. The item data that arises when configuring product variants can be defined generically according to your own wishes and insights. You can use this session to create generic settings on how to generate the item code, item description, material, size, text, or standard for a generic item.

Step 8: Product Configuration Parameters

After you defined the product model, you must change the product configurator version from **Interpreter Version** to **Object Version** in the Product Configuration Parameters (tipcf0100m000) session.

Step 9: Compile Constraints by Generic Item

The last step is to compile the constraints to generate objects for each item in the Compile Constraints by Configurable Item (tipcf2201m000) session.

Process Trigger Definition (tiasl8100m000)

Use this session to define the processes that occur at a specific line station, or the session that is triggered by that event.

Fields	Description
Process	<p>You can use four events as triggers in Assembly Control.</p> <p>These events are:</p> <ul style="list-style-type: none"> ■ Complete Line Station Orders ■ Offset Line Station Orders ■ Start Assembly Order ■ Freeze Line Station Orders
Triggered by Station	<p>The line station on which the event takes place that triggers the session. For example, you can state that the session must be carried out on a main assembly line when the order is completed in a supplying assembly line.</p> <p>You define the trigger in the Process field.</p>
Station	<p>The line station for which the triggered process has to be performed, such as the printing of the work instructions on that line station. This can either be the same line station as the one that triggers the process, or another one.</p>
Assembly Kit	<p>The assembly kit for which the triggered process is performed. This kit should have kit type Product. Kit is only applicable in combination with Session/Model in Replenish Shop Floor Warehouse (tiasc8210m000).</p>
Session/Model	<p>The name of the formal workflow process or the session name of the session that you want to trigger, which you have defined in your workflow model.</p> <p>You can trigger the following sessions:</p> <ul style="list-style-type: none"> ■ Replenish Shop Floor Warehouse (tiasc8210m000) ■ Generate WIP Transfer (tiasc7200m000) ■ Execute WIP Issue (tiasc7201m000) ■ Execute WIP Receipt (tiasc7202m000)

- Start Print Work Instructions (tiasc5451m000)
- Request Start - Assembly Order on Line Station (tiasc4200m000)

Process Type

The name of a process used by the software in the Enterprise Modeler package.

In this field, you have the following options:

- *Formal Workflow Process* This option is not implemented. So, choose the next one.
- *Session A LN session* in the Assembly Control module.

Device

If the process produces a report, the device that prints or displays the report.

Job Sequence Type

The planned requirement date and the planned requirement time of the assembly part requirements are calculated on the basis of what you enter in the **Job Sequence Type** field in the Replenish Shop Floor Warehouse (tiasc8210m000) session.

You can schedule materials based on the planned sequence of the line station for which the materials are scheduled (called-off), but this is not always a realistic solution because the planned sequence can differ from the actual sequence. If the planned and actual sequences differ, you can send a message based on the actual sequence the line station on which the triggers are activated. With this solution, materials are only scheduled for the assembly orders that have already passed the trigger point. LN calculates the arrival times of the materials based on:

- The number of line stations between the supply line station and the trigger line station.
- The cycle time. You can also set triggers based on the planned sequence of the supply station. In this case, LN takes into account line buffer variations, for which a safety lead time can be defined, and the scheduled delay.

Note The planned requirement date of items that are ordered with order-controlled/batch is always based on the planned start times of the assembly orders. Therefore, the calculation of the planned requirement date, based on the actual sequence, can only be used by order-controlled/batch items.

The field can have the values **Planned** and **Actual**.

If the assembly order at **Triggered by Station** is not completed or closed, the **Job Sequence Type** can only be set to **Planned**, because no actual timings will be present for the order at this line station.

You can set the **Job Sequence Type** to **Planned** or **Actual**, if the assembly order at **Triggered by Station** is completed or closed. This is because the

actual timings will be present for the order at this line station. If you select Planned, the assembly parts are ordered in a supply line sequence that is based on the planned start time of the line station order. If you select Actual, the assembly parts are ordered in a sequence that is based on the actual sequence.

You can consider the next sequenced assembly order in the line sequence, if the following conditions are met:

- The assembly parts are order controlled SILS assembly parts.
- The supply messages for the assembly order which triggered the supply are generated. The next sequenced orders are considered on the basis of the batch size that is defined for the KIT in the Items - Warehousing (whwmd4500m000) session in Warehousing.

When the replenish process is executed, order controlled SILS / batch messages are generated. These messages are not automatically transferred to Warehousing and Purchase Control. To transfer these messages, the Transfer Assembly Part Supply Messages (tiasc8220m000) must be run, which is normally run as a scheduled job.

The transfer order number is only filled if the Order Controlled SILS/Batch Messages are transferred to Warehousing and Purchase Control, using the Transfer Assembly Part Supply Messages (tiasc8220m000) session. The Transfer Order Number is filled in the Line Station - Assembly Part Supply Transfer (Batch) (tiasc8510m000) session and in the Assembly Part Supply Transfer (SILS) (tiasc8520m000) session.

Defining a mask

A mask is a template that specifies the structure of identification codes such as serial numbers, lot codes, handling units, and Kanban IDs. A mask defines the total length of the identification code and the way the code is divided up. For a mask example, refer to Example of defining a mask.

Defining and using masks

1. In the Masks (tcibd4102m000) session, define the mask code and description, and the separator between the mask segments.
2. Select the defined mask code in the Masks (tcibd4102m000) session, and start the Mask Segments (tcibd4503m000) session from the appropriate menu to define mask segments. If the segment type is **Translation Table**, which means that the segment consists of a converted value, you must define a translation table.

3. A mask is a general concept in LN to generate identification codes. In places where identification codes are required, you must link a mask for:
 - **Serial numbers**
Define a mask in the Mask by Item/Item Group (tcibd4505m000) session. If no mask is found, LN uses the mask defined in the Item Base Data Parameters (tcibd9199m000) session. For more information, refer to Masks for serialized items.
 - **Lot codes**
Define masks in the Lot Control Parameters (whltc0500m000) session. If no masks are found, LN uses the mask defined in the Item Base Data Parameters (tcibd9199m000) session.
 - **Handling units**
Define a mask in the **Internal Handling Unit Mask** field and the **Shipment Handling Unit Mask** field in the Warehouses (whwmd2500m000) session, or in the Warehouse Master Data Parameters (whwmd0500m000) session.
 - **Kanban IDs**
Define a mask in the **Kanban Signal ID Mask** field in the Warehouses (whwmd2500m000) details session, or in the Warehouse Master Data Parameters (whwmd0500m000) session.

Defining a translation table

If the segment type of a mask segment is **Translation Table**, the segment's value is translated to another value. The translation table contains the original values and the translated values. To define a translation table, take the following steps:

1. Define a translation table in the Translation Tables (tcibd4504m000) session. Note that the use of a translation table is not restricted to one mask. You can use a translation table in multiple masks.
2. Select a translation table in the Translation Tables (tcibd4504m000) session. From the appropriate menu, start the Translation Tables (tcibd4504m000) session to enter the translation table values.

Product variants in Warehousing

This topic describes the effect of a sales order line for an assembly item with an order quantity greater than one in Warehousing. LN displays the product variant in the inbound and outbound procedure of manufactured FAS items. The manufactured FAS items must use serial numbers in inventory to enable LN to recognize each individual assembled item in stock. The product variant is stored in the specification. You must use handling units to link the received serial number and product variant in the specifications to the *to be shipped* serials and specification in the outbound procedure.

You can sell multiples of one single configuration, with the configured item to be built on an assembly line. For order quantity greater than one, LN creates several assembly orders linked to one sales order line. To identify the product variant, the various assembly orders and the sales order line have the same

specification, Specifications are enabled when the **Sell Multiples of Same Configuration** check box in the Assembly Planning Parameters (tiapl0500m000) session is selected.

For more information, refer to the following:

- *Selling multiples of product variants for assembly (p. 35)*
- *Assembly items (p. 117)*
- Product variants in Sales

If an ordered quantity on a sales order line is greater than one, the sales order line contains a product variant which will hold the configuration for the ordered quantity. The product variant is linked to the Specification.

Example

If the ordered quantity for item *car* is 10, it implies that these 10 cars have exactly same unique configuration. In LN, the 10 cars will have the same product variant.

Irrespective of the quantity on the sales order line, the quantity specified on an assembly order is always 1.

Example

In case the ordered quantity for item *car* is 10, 10 assembly orders, each for 1 car, are created. This also implies that multiple assembly orders can have the same product variant reference.

In case the ordered quantity is greater than one, the serial number is not recorded on the sales order line. The specification that contains the variant is used to match the sales issue with the assembled end item in stock.

Supported by LN

The following are supported by LN:

1. *Assembly to Order with Stock Point*

A customer orders a specific configuration of an assembly item, but at completion, the assembled item is put into inventory first before delivery to the customer.

For this scenario, a sales order is entered for a product variant, the assembly order is processed, and the end item is received in stock. Note that in the receipt procedure, the inspection step can lead to an adjustment order with negative quantity only when the item is rejected or destroyed during inspection. A handling unit must be generated during the receipt procedure from the product variant in the specification and the serial of the inbound line originating from LN Assembly Control. The handling unit stores the unique serial number and variant for the item.

After closing of the assembly order, the sales order is processed and stock is issued with the outbound procedure. The outbound line has the product variant in the specification that originates from LN Sales and is related to the same product variant as the receipts that are

completed for the assembly order. During generation of the outbound advice, the specifications in stock are matched with the specifications of the sales order line by checking the product variant. In the picking and shipment procedure also, the product variant of the 'sales order line specification' will be visible.

2. *Assembly to Order (Deliver from Line)*

The customer orders a specific configuration of an assembly item. When the assembly is completed, this item is shipped directly from the assembly line to the customer.

3. *Assembly to Stock/Sell from Stock*

Based on a forecast, a specific configuration is build and put into inventory. Afterwards, this item is sold and shipped from inventory against actual sales orders.

For this scenario, the assembly order is triggered by a forecast and not by a sales order. The issuing sales order is not linked to assembly. When the sales order is created, the inventory with the same product variant is issued from the warehouse.

Note

For scenario 1 (Assembly to Order with Stock Point) and 3 (Assembly to Stock/Sell from Stock) where a configured assembled item (Manufactured/Assembly item) can be put into inventory, the sales order line for a configured assembly item can have an order quantity of more than one.

For scenario 2 {Assembly to Order (Deliver from Line)}, the sales order line quantity is still limited to one piece. In this case, a Generic/FAS (Final Assembly Scheduling) item must be used on the sales order line. The item cannot be put into the inventory

Prerequisites

To sell multiples of a product variant you must do the following:

- Select the **Assembly (APL/ASC/ASL)** check box in the Implemented Software Components (tccom0100s000) session.
- Select the **Sell Multiples of Same Configuration** check box in the Assembly Planning Parameters (tiapl0500m000) session.

Note

- You must use handling units for manufactured FAS items if you select the parameter **Sell Multiples of Same Configuration**.
- If **Demand Pegging** is used, the **Allocation Level** must be **Physical Item** in the Item Data by Warehouse (whwmd2510m000) session for manufactured FAS item.

Allocation Buffers

You must enable **Demand Pegging** to create allocation buffers. You can create allocation buffers for product variants to reserve or allocate inventory. The allocation buffers can be generated or entered manually. You can generate allocation buffers from the following places:

- Planning run in EP
- Sales Order Line entry
- Assembly Order Planning

When an allocation buffer is created for a product variant, the on-hand inventory of the product variant without allocation is decreased, and the on-hand inventory of the product variant with the allocation, (as specified for the allocation buffer) is increased. Also, the inventory in allocation buffer is increased for the product variant with the new allocation.

Note

Allocation buffers for product variants can be created only if there is available unallocated on-hand inventory for the required product variant.

Generate Outbound Advice

The inventory on hand for product variants of manufactured FAS items is always Handling Unit inventory. Therefore, outbound advice treats these product variants of manufactured FAS items as if the **Allocation Level** is **Physical Item**.

You can set the **Allocation Level** to **Physical Item** in the Item Data by Warehouse (whwmd2510m000) session for manufactured FAS item.

During outbound advice generation, the handling units are searched for as follows:

1. LN searches for handling units that have correct specification contents. The specification contents of the handling units must be one-to-one equal to the specification contents of the outbound order line. If everything is not advised, step 2 is carried out.
2. If the specification of the outbound order line has contents without allocations, (for example, only product variant), outbound advice process does not search any further.
3. If the specification of the outbound order line contains allocations and also has other contents, such as product variant, outbound advice searches for handling units with the same specification contents, but without allocations, contents, having available allocation buffer inventory in Inventory by Specification (whwmd2519m000) session. Quantity up to the Inventory in allocation buffer can be advised.

When the outbound advice is created, the location allocated inventory is increased in Inventory by Specification (whwmd2519m000) session. The allocation buffer location allocated inventory is also increased when part of the allocation buffer inventory is advised.

Adjustment and Cycle Counting Order Lines

The new field Product Variant is maintainable only for negative inventory changes. Therefore, lost manufactured FAS items can be removed from the administrative system.

Assembly backflushing

When a line station order is reported complete in the Line Station - Assembly Orders (tiasl6510m000) session or the Report Line Station Order Complete Using Bar Code (tiasc2211m000) session, the material requirements and hours budgeted for that order can be backflushed. You can backflush the materials and hours with the Backflush Requirements (tiasc7241m000) session.

The backflushing topics discussed here are:

- Floor stock
- Backflushing mode
- Quantity of parts backflushed
- Number of hours backflushed

Floor stock

Floor stock items such as nuts and bolts are not backflushed in assembly control. To define an item as floor stock, select the **Floor Stock** check box in the Item - Warehousing (whwmd4600m000) session.

Backflushing mode

Backflushing is carried out for each clustered line-station order (CLSO) (see the Clustered Line Station Orders (tiasc7530m000) session). The number of CLSOs produced each day, depends on the mode you select with the **Transaction Processing** parameter, which you define in the Assembly Control Parameters (tiasc0100m000) session. For **Order Based** processing, each individual assembly order provides a CLSO for each line station, creating many CLSOs each day. For **Line Station Based** processing, there is only one CLSO each day, for each line station. All the hours and materials for all buckets, all line-station variants, and all line-station orders are clustered into one CLSO for each line station. This mode is for high-volume production environments.

Assembly parts

The parts required by the line station variant can be backflushed after the line station order is reported complete, with the Backflush Requirements (tiasc7241m000) session. The quantities required are calculated as described for the Build Assembly Part Allocation (tiasc7240m000) session. LN activates a warehousing order line which ensures the parts are delivered to the correct shop floor warehouse.

Floor stock items such as nuts and bolts are not backflushed in assembly control. To define an item as floor stock, select the **Floor Stock** check box in the Item - Warehousing (whwmd4600m000) session.

Man hours and machine hours

Man hours (also known as person hours) and machine hours are backflushed to People.

The number of hours backflushed is the sum of $CT \times MO$ (Cycle Time x Man Occupation or Machine Occupation) for each line station variant, summed for either the assembly line, if **Line Station Based**, or for the line station, if **Order Based**.

- If it is **Line Station Based**, the cycle time comes from the Assembly Line - Assignments (tiasc5510m000) session.
- If it is **Order Based**, the cycle time comes from the Line Station Variant - Operations (tiasc2122m000) details session. You define the occupation in the Assembly Line - Assignments and Line Stations (tiasc5520m000) session, if **Line Station Based**, and in the Line Station Variant - Operations (tiasc2122m000) session, if **Order Based**.

If hours are present, the hours transactions with the status Closed are posted to People and processed automatically. The hours are posted to the employee linked to the line station. You can view the hours with the Assembly Hours (bptmm1160m000) session. You can also enter additional hours with this session.

Note

In the Assembly Control Parameters (tiasc0100m000) session, the **Transaction Processing** field determines how hours are booked:

- **Order Based**
Hours are booked for an individual assembly order. **Order Based** is used in low-volume environments.
- **Line Station Based**
The hours for line-station orders is added together, for each line station, to form one clustered line-station order (CLSO) for each day. **Line Station Based** is used in high-volume environments.

The values that are visible in the Clustered Line Station Orders (tiasc7530m000) session are used by Warehouse Management. When material backflushing is performed, the inventory for the assembly part is backflushed from Warehousing, and the Planned stock transactions in the Order - Planned Inventory Transactions (whinp1501m000) are reduced.

Appendix A

Glossary



address

A full set of address-related details, which include the postal address, access to telephone, fax, telex numbers, and email, Internet address, identification for taxation purposes, and routing information.

allocation

An item quantity that is assigned to a specific order but that is not yet released from the warehouse to production.

appropriate menu

Commands are distributed across the **Views**, **References**, and **Actions** menus, or displayed as buttons. In previous LN and Web UI releases, these commands are located in the *Specific* menu.

as-built structure

The actually built structure of a product including the serial numbers.

assembly assignment

The set of resources assigned to an assembly line for a particular period of the day. The resources are divided over the line stations to create a balanced line.

Assignments are defined for an assembly line. For each assignment, you specify the cycle time and its activity ranges, which are the period and time ranges for which the assignment is effective. The process characteristics that you define for an assignment include:

- Man occupation
- Machine occupation
- Work team
- Operations

These process characteristics are linked to other assignments that are, in turn, linked to the assembly assignment. When an assignment is in effect, the assignments that are linked to it are also in effect.

assignment types

Two types of assignments exist, both of which exist at the same time. The average assignment is used for more general purposes, whereas the nonaverage assignment has a very specific period and time range.

- **Average assignments**
Use an average cycle time that is based on the cycle times of the nonaverage assignments for the day. The average assignment is used in planning. Planning is based on cycle time, calendar, and availability type.
- **Nonaverage assignments**
Use time-based cycle times that are based on the operations performed on the line. The cycle time can vary according to the time range that is provided for the assignment.
Nonaverage assignments are used to define order content. For generated (nonfrozen) orders, the order content is based on the first active, nonaverage assignment. For frozen orders, the order content is based on the nonaverage assignment that is in effect at the time that the order is frozen.
Nonaverage assignments are also used to offset the lead time during sequencing. When the order is sequenced, a lead time is calculated for every order. This lead time is based on the cycle times, and the applicable cycle time is retrieved from the nonaverage assignment.

Note

An average cycle time is not a mathematical average, but is a value that you consider to be a suitable average for the nonaverage cycle times over the course of a full day.

assembly item

An item with default supply source **Assembly**. The production of assembly items is controlled by an assembly order. Assembly orders are executed on an assembly line.

Note

An assembly item can have item type **Generic, Manufactured, Engineering Module, or Product**.

assembly line

A set of consecutive line stations in which FAS (Final Assembly Schedule) items are manufactured. The items are manufactured by passing the items from line station to line station and by carrying out operations at each line station. An assembly line is subdivided into a number of line segments separated by buffers. An assembly line can be either a main line or a supplying line.

assembly order

An order to assemble a product on one or more assembly lines.

assembly part

A component used on an assembly line.

An assembly part forms the link between Configurator and Enterprise Planning. Configurator generates the requirements for assembly parts and Enterprise Planning plans the production or purchase of the item.

backflushing

The automatic issue of materials from inventory, or accounting for the hours spent manufacturing an item, based on theoretical usage and the quantity of the item reported as complete.

bar code

A series of alternating bars and spaces printed on documents or products, representing encoded information that can be read by electronic scanners.

bill of material (BOM)

A list of all parts, raw materials, and subassemblies that go into a manufactured item and show the quantity of each of the parts required to make the item. The BOM shows the single-level product structure of a manufactured item.

BOM sequence number

The BOM sequence number allows you to define more than one component item for each position. These interchangeable components can have different dates when they are valid.

LN also uses sequence numbers when you replace items in BOMs.

Example

Say, you make bicycles and use frames that you buy from supplier A until August. However, after August you will use identical frames that you buy from supplier B. Do not use a new BOM position number for the second frame. Instead, use a new sequence number.

bucket

A quantity of time used for planning and backflushing.

buffer

An assembly line workstation where no operations are carried out, and where orders are waiting to enter the following work station.

You can use buffers to change the sequence of products from one line segment to another. Buffers in LN are random access type.

buffer (FIFO)

The orders that came in first go out first. As a result this buffer is just a 'pipeline' which can have a certain capacity. No planned sequence change can take place so no line rules can be linked to FIFO buffers.

buffer (random access)

Buffers with random access places. During the sequence process, LN checks these access places to achieve a proper sequence on the next line segment. Line rules can be linked to random access buffers. Line rules sequence the assembly orders which enter the random access buffer.

calculation office

A work center of the type **Costing** that is used to determine the enterprise unit for a project, or production order and also has an administrative function.

Note

When linked to production orders, the **Use as Calculation Office** check box in the Work Centers (tirou0101m000) session must be selected for the work center.

CLSO

See: *clustered line station order* (p. 141)

clustered line station order

Represents all the material requirements for a line station for a day. A CLSO consists of user-defined buckets. The material requirements are combined for each bucket.

In Assembly Control, transactions can be carried out per line station and per period, instead of per order. LN can combine the same materials for a specific period into one material line. After doing so, the cumulated quantity is stored in the CLSO. This accumulation reduces the number of transactions that are necessary, because the transactions are performed for a specific bucket.

Acronym: CLSO

See: [bucket](#)

company

A working environment in which you can carry out logistic or financial transactions. All the transaction data is stored in the company's database.

Depending on the type of data that the company controls, the company is:

- A logistic company.
- A financial company.
- A logistic and a financial company.

In a multicompany structure, some of the database tables can be unique for the company and the company can share other database tables with other companies.

compile

To translate all the source code of a program from high-level language into object code prior to execution of the program. Object code is an executable machine code or a variation of machine code.

configurable item

An item that has features and options and must be configured before any activities can be performed on it. If the configurable item is generic, a new item is created after configuration. If the item is manufactured or purchased, the configuration is identified by item code and option list ID.

- **Manufactured or Product** items with the default supply source set to **Assembly** and **Generic** items are always configurable.
- **Purchased or Product** items with a purchase schedule in use can be configurable.
- Configurable **Purchased or Product** items can be used within Assembly Control only.

configured item

A configurable item that is configured, which means options and features are chosen for the item.

A configured item can have components that are also configured, for example, a bike with a bike light. If a configured item is an end item, it is configured with its configurable components and stored as a product variant.

constraint

In LN, a means to check, restrict, or compel to avoid or perform some action.

In the Product Configuration module, a constraint is every possible decision rule or calculation conceivable that can be carried out during the definition of the product variants. You can use constraints in the product model for product features, generic BOMs, routings, price lists, and item data. You can use a constraint editor to define constraints.

Among other things, constraints allow you to indicate under which conditions certain combinations of options are acceptable, mandatory, or not acceptable for product features. You can also indicate which bill of material components and/or operations must be included or excluded, what the purchase or sales price structure for a product variant is, and so on.

In the Product Classification module, a constraint consists of one or more constraint lines that define the conditions under which certain return values or calculation results are included in the classification code during item classification.

constraint

A set of decision rules (constraints) that control the translation of the customer requirements into the product structure of the variant. These constraints indicate which components and operations will be used in a specific product variant.

cost component

A cost component is a user-defined category for the classification of costs.

Cost components have the following functions:

- To break down an item's standard cost, sales price, or valuation price.
- To create a comparison between the estimated production order costs and the actual production order costs.
- To calculate production variances.
- To view the distribution of your costs over the various cost components in the Cost Accounting module.

Cost components can be of the following cost types:

- **Operation Costs**
- **Material Costs**
- **Surcharge**
- **General Costs**
- **Not Applicable**

Note

If you use Assembly Control (ASC), you cannot use cost components of the **General Costs** type.

cycle time

In LN, the time between completion of two separate units of production. For example, the cycle time of motors assembled at a rate of 120 per hour is 30 seconds.

The cycle time is also equal to the time that a product stays in one position on an assembly line, or the time that an operation is carried out on an item in a work station (excluding setup time).

default supply source

The source that supplies an item by default. You can use purchase orders or schedules, production orders or schedules, assembly orders, or warehousing orders to supply an item.

The default supply source determines what type of order is used to supply the item, but in general, you can override the default and specify an alternate source.

demand peg

A relationship between a planned order, or an actual supply order, and an item requirement that represents a definite commitment.

You can only use the demand pegged supply for the pegged requirement, unless either of these conditions applies:

- The peg is deleted.
- Parameters allow issuing unallocated inventory or inventory of a different specification for a demand-pegged outbound order.
- **Pegged supply**
The pegged supply can be a purchase order, a planned purchase order, a production order, a planned production order, a warehousing order with transaction type transfer, or a planned distribution order.
- **Pegged requirement**
The pegged requirement can be, among other things, a sales order line or a required component for a production order.

Related term: soft peg

effective date

The date on which the validity of the materials or the operations is checked.

The application considers a material or operation to be valid, if this date is within the effective date and the expiry date range.

The effective dates are used in the explosion process to create demands for the correct items.

effectivity unit

A reference number, for example a sales order line or a project deliverable line, that is used to model deviations for a unit effective item.

efficiency variances

A part of the production result that is created by differences between the estimated and actual material quantities and hours.

The efficiency variance shows how efficiently materials and resources are used.

E-item

See: *engineering item* (p. 145)

end item

An item that is ready to be delivered to a warehouse. An end item is produced at the end of a dangle routing (co-products and by-products) or a main routing.

engineering item

An item in the process of development.

You can define multiple revisions of an engineering item. Typically, the most recent revisions are still in a design or test phase, another revision may have been taken into production, and older revisions are obsolete.

A normal item can only become revision-controlled when it is copied from the Engineering Data Management module.

Synonym: E-item

engineering module

A virtual item that is used to model a fixed part of a product engineering structure in Assembly Planning in Manufacturing. The product engineering structure is used to generate assembly orders for the Assembly Control module of Manufacturing.

The engineering module is the top of a tree structure (BOM) of engineering items. If Assembly Planning generates the assembly orders, the **Engineering Module** item type is created in the Item Base Data tables in LN, if not yet present. The engineering module is part of the order content and the as-built structure.

engineering module

In Assembly Planning, a system, or, in other words, a logical unit of assembly parts, that is typically not manufactured as a separate physical unit.

For example, the electrical system of a car is the logical unit of all parts required for the electrical system. It is, however, not manufactured as a separate physical unit, but integrated in the dashboard, doors, and so on.

An engineering module has no routings, assembly lines, options, and so on, and is for design and planning purposes only. In the bill of materials (BOM), the engineering module is the top layer of the nonconfigurable section of the BOM.

enterprise unit

A financially independent part of your organization that includes entities such as departments, work centers, warehouses, and projects. The enterprise unit's entities must all belong to the same logistic company, but a logistic company can contain multiple enterprise units. An enterprise unit is linked to a single financial company.

When you carry out logistic transactions between enterprise units, the resulting financial transactions are posted to the financial companies to which each enterprise unit is linked.

exchangeable configuration

A configuration is exchangeable with another configuration at a particular point on the assembly line, if at that point the two configurations have the same specifications.

FAS item

A generic item with the FAS (Final Assembly Scheduling) order system.

FAS items are produced in a mixed model flow process on an assembly line.

feature

A characteristic of a configuration class. It can be any kind of property that can hold a certain value. An example of a feature is color.

Class features can be:

- Mandatory
- Persistent (can be saved)
- Private (cannot be used outside the configuration model)
- Active (is in use)
- Explicit (derived from)

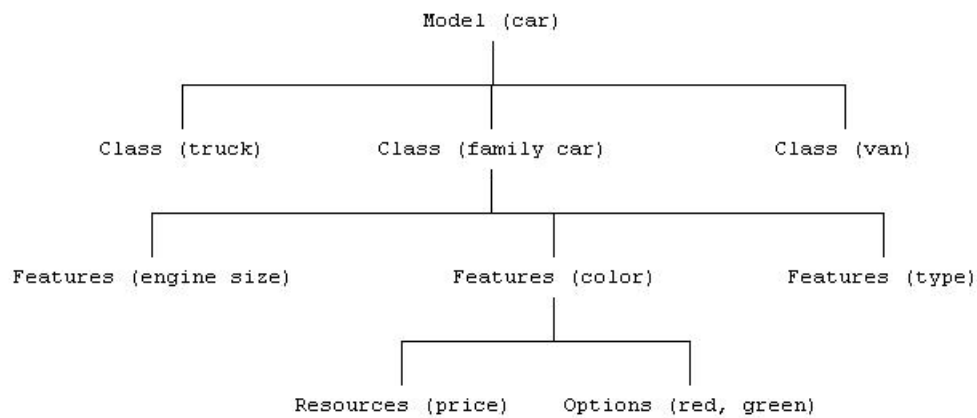

Note

You can link as many features as you like to a class. You can link only one option to a feature.

feature

Characteristics which can be combined and subsequently be linked to configurable items to compose a product variant. An example of a feature is color.

flatten

To bring down a multilevel structure to one level. As a result, all elements of the hierarchical structure are the direct children of the parent item. This process can be used to enhance the calculation of assembly part requirements.

Example

Once in while, a product structure is flattened, and the result is stored separately. This way, LN does not need to browse the structure each time the assembly part requirements are calculated, because all parts that are required can be read at once.

floor stock

A stock of inexpensive material present in the job shop that can be used in production without recording each issue of material individually. Floor stock is not backflushed and is not part of the estimated costs.

freeze

To deactivate line stations, line segments, line station orders, and the like. If something is frozen, no changes are allowed. For example, a line station order can be frozen because the production process is too far advanced to be able to process the change.

generic BOM

Set of components, per generic item, from which product variants can be composed. The generic bill of material forms the basis for the variant bill of material which arises during the configuration/generation of a product variant. For each BOM line (component) a constraint rule may apply.

generic item

An item that exists in multiple product variants. Before any manufacturing activities are performed on a generic item, the item must be configured to determine the desired product variant.

Example

Generic item: electric drill

Options:

- 3 power sources (batteries, 12 V or 220 V)
- 2 colors (blue, gray).

A total of 6 product variants can be produced with these options.

handling unit

A uniquely identifiable physical unit that consists of packaging and contents. A handling unit can contain items. A handling unit has a structure of packaging materials used to pack items, or is a part of such a structure.

A handling unit includes the following attributes:

- Identification code
- Packaging item (optional)
- Quantity of packaging items (optional)

If you link an item to a handling unit, the item is packed by means of the handling unit. The packaging item refers to the type of container or other packing material of which the handling unit consists. For example, by defining a packaging item such as Wooden Crate for a handling unit, you specify that the handling unit is a wooden crate.

See: handling unit structure

inbound-order line

A warehousing-order line used for the inbound of goods. An inbound-order line gives detailed information about planned receipts and actual receipts.

For example:

- Item data
- Ordered quantity
- Warehouse and location of receipt

inspection

To measure, examine, test, or gauge one or more characteristics of a product or service. After doing this, you can compare the results with the specified requirements to determine whether conformity is achieved for each characteristic.

Inspection is often performed on delivered goods upon arrival.

inventory unit

The unit of measure in which the inventory of an item is recorded, such as piece, kilogram, box of 12, or meter.

The inventory unit is also used as the base unit in measure conversions, especially for conversions that concern the order unit and the price unit on a purchase order or a sales order. These conversions always use the inventory unit as the base unit. An inventory unit therefore applies to all item types, also to item types that cannot be kept in stock.

inventory valuation method

A method to calculate the inventory value.

The inventory is valued at either its standard cost or its actual receipt price. Because inventory value can change with time, the age of inventory needs to be noted. In LN, the following inventory valuation methods are available:

Valuation Method

item

The raw materials, subassemblies, finished products, and tools that can be purchased, stored, manufactured, and sold.

An item can also represent a set of items handled as one kit, or which exist in multiple product variants.

You can also define nonphysical items, which are not retained in inventory but can be used to post costs or to invoice services to customers. The examples of nonphysical items:

- Cost items (for example, electricity)
- Service items
- Subcontracting services
- List items (menus/options)

item type

A classification of items used to identify if the item is, for example, a generic item, a service item, or an equipment item. Depending on the item's type, certain functions will only apply to that item.

JIT item

See: *just-in-time item* (p. 149)

just-in-time item

An item of which the procurement is controlled using purchase schedules instead of ordinary purchase orders. The purchase schedule corresponds to a regular series of deliveries during a certain time period.

Acronym: JIT item

kanban

A demand-pull system of just-in-time production that regulates the supply of items to shop floor warehouses.

Kanban uses standard containers or lot sizes (also called bins) to deliver items to shop floor warehouses. In the shop floor warehouse, two or more bins are available with the same items. Items are only taken from one bin. Typically, if a bin is empty, a new bin is ordered and the items are taken from the (second) full bin. To each bin a label is attached. The line stations use the label to order a full bin with the required items.

Sometimes, not every bin is provided with a label. For example, a label is attached to every second bin. When both bins are empty, the user scans the label of the second empty bin to generate a supply order for both empty bins.

lead time

The time between the production start date and the delivery date. The lead time can include order preparation time, transportation time, and inspection time.

line segment

A set of consecutive assembly-line work centers on an assembly line between two buffers. The first buffer is the beginning of the segment, the next buffer is the first part of the next segment.

line sequencing

The determination of the sequence order used to start the production of items in a segment of a production line. The sequence order may be changed from one line segment to the next.

line station

A work center that is part of an assembly line. A line station is used in the production of FAS (final assembly schedule) items. A line station can have multiple positions, which enables more than one item to be present in one line station.

line station order

Production order for an assembly line station.

line-station variant

Holds identical operations and materials that are used at a specific line station for multiple assembly orders. In this manner, the identical operations and materials are stored only once, rather than for each assembly order. When line station variants are used, less data storage is required, and the performance is enhanced.

Example

You produce cars with various features, including two types of wheels: broad and narrow. In the wheel line station, in which the wheels are fitted, all cars with broad wheels are one line station variant, and cars with narrow wheels are another line station variant, regardless of any other specifications, because the other specifications are not relevant to the wheel line station.

Synonym: LSV

lot

A number of items produced and stored together that are identified by a (lot) code. Lots identify goods.

lot item

An item that is subject to lot control.

LSV

See: *line-station variant* (p. 151)

main assembly line

An assembly line that produces end products. An assembly line is a set of consecutive line stations where FAS (Final Assembly Schedule) items (and sometimes other item types) are manufactured.

main item

The end result of a production order.

A main item is either be changed to an end item (for delivery to a warehouse), or delivered directly to the customer in bulk.

mask

A template that specifies the structure of an identification code. A mask is used to generate the identifier for a shift when it is generated through either the Update Calendar Working Hours (tcccp0226m000) session.

See: mask segment

mask segment

A part of a mask that represents specific data. For example, a mask segment can be a date, a LN field, or a sequence number.

See: mask, translation table

mass BOM change

A mechanism to simultaneously make multiple changes to the engineering bills of material of several items.

You can use mass bill of material changes to concurrently carry out several of the following actions:

- Modify EBOM lines
- Copy E-item revisions to production items
- Copy EBOMs to productions BOMs

Synonym: MBC

master company

In a multicompany situation, a master company is used to synchronize data in all companies. Data that is entered or generated in the master company, for example, the line structure, can be replicated to the other companies. The master company can either be one of the companies of the assembly lines, or a separate company.

material

The raw materials, components, and subassemblies used to manufacture an item. A cost item, for example, electricity, can also be treated as a material.

MBC

See: *mass BOM change* (p. 152)

multicompany

From a logistical point of view, multicompany relates to the flow of goods or information between multiple locations, which are implemented in different logistic companies. Typically, these locations are situated in various regions or countries.

From a financial point of view, multicompany relates to the financial flow between financial entities, represented by departments and warehouses, which are implemented in different financial companies. Typically, these warehouses and departments are located in various countries or belong to different business units.

multilevel bill of material

A BOM that lists the subcomponents of the components, and any eventual subcomponents.

In the multilevel BOM, the final product is at level zero.

offsetting

To plan orders to account for the cumulative lead-time of the production process.

operation

One of a series of steps in a routing that are carried out successively to produce an item.

The following data is collected during a routing operation:

- The task. For example, sawing.
- The machine used to carry out the task (optional). For example, sawing machine.
- The place where the task is carried out (work center). For example, woodwork.
- The number of employees required to carry out the task.

This data is used to compute order lead times, to plan production orders and to calculate standard cost.

option combination

A specific combination of product options, for example, color or style, that are related to an assembly order.

Each option combination is either a single option, or a combination of other option combinations.

order controlled/Batch

A demand-pull system that regulates the supply of items to shop floor warehouses.

In this supply system, items that are required at a particular line station of the assembly line are called off at an earlier line station, called the trigger-from station. The number of items that is called off depends on what is needed on the assembly line in a specified time fence, called the maximum time interval.

In general, the items that are supplied to the shop floor warehouse by batch, are fast movers and are processed in high volumes. There is no direct link between these items and the assembly orders they are used for. In addition, one warehouse order set can be used to supply the goods needed by several assembly orders.

order system

The order parameter that controls the way by which recommended purchase and production orders are generated.

Options:

- **FAS** (final assembly scheduling).
- **SIC** (statistical inventory control).
- **Planned** (schedule-based and order-based planning).
- **Manual** (manual reordering).

order type

A group of orders that are processed according to the same procedure (series of order steps = sessions). In addition, these orders share a number of other characteristics (return order y/n, collect order y/n, subcontracting order y/n, and so on).

parallel assembly operations

An assembly line network in which you can perform same operations on different assembly lines simultaneously or model a network in which a supply line feeds multiple supply lines which again converge at a later stage into a single line.

PBOM

See: *production BOM* (p. 155)

person hours

The unit of work equal to one person working for one hour. The terms man-hours and person-hours are used interchangeably.

physical breakdown

A serialized item's composition and structure, defined by the parent-child relationships of its constituent items. The physical breakdown can be displayed in a multilevel structure or a single-level structure.

physical location

The room, building, or construction site where an operation is carried out.

planned offline date

The date when an assembly item is planned to roll off the assembly line.

Initially, the planned offline date equals the requested offline date, but the planned offline date can be changed later for planning reasons.

price variances

The price variance of a production order is the part of the production result created by differences between the estimated and actual price of an item or hour.

The price variance indicates the effect of changing rates and prices on the production result.

process-triggered workflow

Workflow in which actions are triggered by an activity, or batch or activities, in another line station.

production BOM

A type of bill of material (BOM) that contains a list of materials and the information about the way the parts and materials detailed in the BOM relate to each other in assembly.

Acronym: PBOM

production order

An order to produce a specified quantity of an item on a specified delivery date.

product model

Used in the definition of the product variant in making a sales order or quotations by translating the customer requirements into a product variant

product structure

The sequence of steps by which components are put together to form subassemblies, until the finished product is produced.

The product structure is defined by a multilevel bill of materials, sometimes in combination with routing data.

product variant

A unique configuration of a configurable item. The variant results from the configuration process and includes information such as feature options, components, and operations.

Example

Configurable item: electric drill

Options:

- 3 power sources (batteries, 12 V or 220 V)
- 2 colors (blue, gray).

A total of 6 product variants can be produced with these options.

product variant structure

The structure of the product variant, which consists of one configurable end item that is related to several configurable sub-items and/or engineering modules.

Configurable sub-items can also have their own configurable sub-items and/or engineering modules. The configurable items represent the product and the subassemblies of the product. The engineering modules are used for assembly items and represent logical units that may not constitute independent products, such as an electrical system. The product variant structure is generated by LN and, dependent on the options, holds a part of the bill of material.

project item

An item that is produced or purchased for a particular sales order. The item's project provides a link with the sales order.

A project item can be recognized by its item code. If a code has been entered in the project segment, the item is a project item.

A project item can be customized to the specifications of a customer, but it can also be a standard-to-order item.

purchase schedule

A timetable of planned supply of materials. Purchase schedules support long-term purchasing with frequent deliveries and are usually backed by a purchase contract. All requirements for the same item, buy-from business partner, ship-from business partner, purchase office, and warehouse are stored in one schedule.

reference type

A product variant may relate to a sales quotation, sales order, budget or project, or it may concern a standard variant.

requested offline date

The date when an assembly item must roll off the assembly line in order to meet the delivery date on the sales order line.

revision

A version or revised version of an engineering item (E-item) or a revision-controlled item, that is, an item linked to an E-item. Several revisions of an E-item can exist.

Example

E-item: Mountain bike E-MB01

Revision	Description	Status
A1	Draft drawing of bike	Not released
A2	Drawing of bike	Not released
A3	Parent E-item of bike MB01	Released
A4	Obsolete bike	Canceled

revision-controlled

The revision-controlled items are items in continuous development. To identify the item's version, add a revision number to the item code.

If a revision-controlled item is selected, the current version is used. The obsolete versions are no longer manufactured and prototypes are not sold yet.

rework order

A production order to fix or upgrade an already produced or purchased item. The item that must be reworked is both input and output of the production order.

roll-off line

The assembly line where a product is completed.

routing

The sequence of operations required to manufacture an item.

For each operation, the task, machine, and work center are specified, as well as information about setup time and cycle time.

sales order lines

A sales order contains items that are delivered to a customer, according to certain terms and conditions. The lines of a sale order are used to record the items ordered, as well as the associated price agreements and delivery dates.

scrap

Unusable material or rejects of intermediate products, for example, because of faulty components, or products lost in cutting or sawing operations. The gross material requirements and/or an operation's input quantity must be increased to account for anticipated scrap.

In the BOM, you can define scrap as a percentage of the net material requirements, which is the scrap factor, and as a fixed quantity, which is the scrap quantity. A scrap quantity is mostly used to define the amount of material that is lost every time when you start producing, for example, to test the equipment.

For an operation, you can only define the scrap as a fixed quantity.

segment schedule

A schedule that indicates when assembly parts are required. Based on the offline date of the assembly order, and the segment for which the assembly parts are required, the segment schedule indicates when the parts must be delivered to the line. Segment schedules are used for a rough calculation of assembly part requirements, when high volumes are processed, and the performance of the calculation is critical.

serialized item

A physical occurrence of a standard item that is given a unique lifetime serial number. This enables tracking of the individual item throughout its lifetime, for example, through the design, production, testing, installation, and maintenance phases. A serialized item can consist of other serialized components.

Examples of serialized items are cars (Vehicle Identification Number), airplanes (tail numbers), PCs, and other electronic equipment (serial numbers).

serial number

The unique identification of a single physical item. LN uses a mask to generate the serial number. The serial number can consist of multiple data segments that represent, for example, a date, model and color information, sequence number, and so on.

Serial numbers can be generated for items and for tools.

shop floor warehouse

A warehouse that stores intermediate inventory in order to supply work centers. A shop floor warehouse is linked to an individual work cell, an assembly line, or one or more work centers. A shop floor warehouse can be supplied with goods using replenishment orders, or by pull-based material supply.

The pull-based material supply methods are:

- **Order Controlled/Batch** (only applicable in Assembly Control).
- **Order Controlled/SILS** (only applicable in Assembly Control).
- **Order Controlled/Single** (only applicable in Job Shop Control).
- **KANBAN.**
- **Time-Phased Order Point.**

The items stored in the shop-floor warehouse are not part of the work in process (WIP). When items leave the shop floor warehouse for use in production, their value is added to the WIP.

specification

A collection of item-related data, for example, the business partner to whom the item is allocated or ownership details.

LN uses the specification to match supply and demand.

A specification can belong to one or more of the following:

- An anticipated supply of a quantity of an item, such as a sales order or production order
- A particular quantity of an item stored in a handling unit
- A requirement for a particular quantity of an item, for example a sales order

standard cost

The sum of the following item costs as calculated by the standard cost calculation code:

- Material costs
- Operational costs
- Surcharges

Prices that are calculated against other price simulation codes are simulated prices. The standard cost is used for simulation purposes and in transactions when no actual price is available.

Standard cost is also an inventory valuation method for accounting purposes.

standard item

A purchased item, material, subassembly, or finished product that is normally available.

All items that are not built according to customer specification for a specific project are defined as standard items. Opposite term is customized item.

subassembly

An intermediary product in a production process that is not stored or sold as an end product, but that is passed on to the next operation.

For subcontracting purposes, a manufacturer can send a subassembly to a subcontractor to carry out work on the subassembly. This subassembly has its own item code defined in the Item Base Data.

After work is finished, the subcontractor sends the subassembly back to the manufacturer. Also this reworked subassembly has its own item code defined in the Item Base Data.

supplying assembly line

An assembly line which produces subassemblies that are used in another assembly line. It may additionally produce items that are not used on any assembly line. An assembly line is a set of consecutive line stations where FAS (Final Assembly Schedule) items (and sometimes other item types) are manufactured.

supply in line sequence

The supply of assembly parts or assembly kits to a shop floor warehouse, so that they are delivered to the line station in the same sequence as the assembly orders.

time fence

The date until which an item's supply plan and planned orders are frozen.

The time fence is expressed as a number of working days or working hours from the date you carry out the simulation.

As a rule, Enterprise Planning does not regenerate the supply plan or the planned orders within the time fence. However, you can overrule this behavior when you run a master-plan simulation or order simulation.

The time fence is meant to prevent:

- Disturbance of orders that have already started (at the shop-floor level).
- Generation of planned orders with start dates in the past (that is, orders that are late).

Usually, the lead time of an item's production process is a reasonable value for the time fence.

translation table

A table to translate the actual data into the code required to form the serial number. For example, to translate the production date into the date code.

unit effective item

An item for which an effectivity unit can be defined on the sales order line or the sales quotation line. The effectivity unit is used to model deviations for the unit effective item, and to peg purchase orders and production orders to a specific sales order line for the unit effective item.

unit effectivity

A means to control the validity of variations by effectivity units.

Unit effectivity enables you to model changes for the following entities:

- Engineering bill of material
- Production bill of material
- Routing
- Routing operations
- Supplier selection
- Sourcing strategies

upgrade price

A price that is defined for a requirement in Unit Effectivity (UEF). If the requirement is used in an effectivity unit's configuration, the upgrade price is added to the effectivity unit's sales price.

warehouse order

See: *warehousing order* (p. 161)

warehousing order

An order for handling goods in the warehouse.

A warehouse order can be of the following inventory-transaction types:

- **Receipt**
- **Issue**
- **Transfer**
- **WIP Transfer**

Each order has an origin and contains all the information required for warehouse handling. Depending on the item (lot or non-lot) and warehouse (with or without locations), lots and/or locations can be assigned. The order follows a predefined warehousing procedure.

Note

In Manufacturing a warehousing order is often called a warehouse order.

Synonym: warehouse order

WIP transfer

The transfer of the value of the work in process from one work center to the next, in accordance with a physical transfer of a subassembly to the work center where the next operation must be performed.

work center

A specific production area consisting of one or more people and/or machines with identical capabilities, that can be considered as one unit for purposes of the capacity requirement planning and detailed scheduling.

yield

The usable output from a operation expressed as a percentage of its input.

Example 1: An operation in the production process for light bulbs has a yield of 98%. So, out of every 100 light bulbs produced, 98 are good on average. The remaining light bulbs are faulty, and will therefore be rejected.

Example 2: Steel wires are twisted together to produce a steel cable. Due to the twisting, the cable is 10% shorter than the wires from which it is produced. So, the yield is set to 90%.

Index

- Actualize Cost Component Scheme**
 - calculate standard cost, 57
 - address**, 137
 - allocation**, 137
 - Allocation**
 - allocation, 93
 - and actualize cost component structures**, 57
 - appropriate menu**, 137
 - as-built structure**, 137
 - As-built structure**, 85, 88
 - assembly assignment**, 138
 - Assembly Control (ASC)**
 - Assembly Control, 115
 - Assembly control exercise introduction**, 15
 - Assembly control**
 - post-assembly operations, 105
 - storing generic items, 123
 - assembly item**, 139
 - Assembly Items**
 - assembly items, 117
 - assembly line**, 139
 - Assembly Line**
 - costing data, 57
 - Assembly line selection**
 - Configuration Dependent parameter, 24
 - Assembly Line Structure**
 - product structure, 33
 - Product Structure, 37, 37, 39, 40, 41, 43, 46, 48, 49, 50, 57, 69, 71
 - Assembly materials**, 134
 - Assembly operations**, 59
 - assembly order**, 139
 - Assembly Orders**
 - costing, 118
 - assembly**
 - Part, 93
 - assembly part**, 139
 - Assembly**
 - part, 93
 - product variant, 35
 - Assembly variant**, 82
 - Backflush Assembly Parts**
 - backflush assembly parts, 101
 - Backflush Hours**
 - backflush hours, 101
 - backflushing**, 139
 - Backflusing in assembly control**, 134
 - bar code**, 139
 - bill of material (BOM)**, 139
 - BOM sequence number**, 140
 - bucket**, 140
 - buffer**, 140
 - buffer (FIFO)**, 140
 - buffer (random access)**, 140
 - Build Assembly Part Allocation**
 - build assembly part allocation, 93
 - business processes supported in LN**
 - Introduction, 15
 - Business Processes Supported in LN**
 - introduction, 11
 - Calculate Assembly Part Requirements**, 75, 84
 - Calculate cost prices and actualize cost component structures**, 69, 71
 - Calculate Standard Cost**
 - actualize cost component scheme, 57
 - calculation office**, 140
 - CLSO**, 141
 - clustered line station order**, 141
 - company**, 141
 - compile**, 141
 - Completing**
 - line station orders, 97
 - configurable item**, 141
 - Configuration Dependent parameter**
 - assembly line selection, 24
-

configured item, 142
constraint, 142, 142
cost component, 143
Costing
 assembly orders, 118
Costing Data
 assembly line, 57
Create Assembly Parts Inventory
 link generic items to assembly lines, 49, 50, 69, 71
Create Constraints by Generic Item
 link product features to generic item, 49, 50, 69, 71
Create Generic BOM
 Create Sales Price List for generic item, 49, 69, 71
Create Operations, 41, 43
Create Sales Order (Line)
 review product variant, 75, 84
Creation of assembly orders, 80
cycle time, 143
default supply source, 143
Define Assembly Line Assignment, 39, 40, 41, 43
 process engineering, 46, 48
Define Inventory Valuation method
 Manufactured assembly item, 48
Define Option Combinations, 69, 71
Define Sequence Parameters for Line segments, 71
Delete Assembly Orders
 assembly orders, 116
demand peg, 144
Divergent assembly lines
 linking supply line to multiple parent lines, 16
EDM summary, 45
effective date, 144
effectivity unit, 144
Effectivity units, 108
efficiency variances, 144
E-item, 145
end item, 144
Engineering data management
 effectivity units, 107
engineering item, 145
Engineering items, 45
engineering module, 145, 145
enterprise unit, 145
exchangeable configuration, 145
Executing WIP Transfer, 101
FAS backflushing, 134
FAS item, 146
FAS orders, 80
feature, 146, 146
Final assembly line sequencing, 59
flatten, 147
floor stock, 147
freeze, 147
 Assembly orders, 95
Freeze
 assembly orders, 95
Generate Assembly Orders
 Review Assembly Orders, 84
generic BOM, 147
generic item, 147
Generic items
 Storing completed items, 123
handling unit, 148
inbound-order line, 148
inspection, 148
Introduction, 11
 business processes supported in LN, 15
inventory unit, 148
inventory valuation method, 149
item, 149
Item Data
 Product engineering - An Introduction, 46, 48
item type, 149
JIT item, 149
just-in-time item, 149
kanban, 150
lead time, 150
line segment, 150
Line Segments, 46, 48
 process engineering, 37, 39, 40, 41, 43
line sequencing, 150
Line sequencing, 59
line station, 150
line station order, 150
Line Station Orders
 completing, 97
line-station variant, 151
Linked Assembly Lines
 transportation time, 29, 90
Linking supply line to multiple parent lines
 divergent assembly lines, 16

Link supply line to multiple supply lines

- assembly line selection, 24

lot, 151**lot item**, 151**LSV**, 151**main assembly line**, 151**main item**, 151**mask**, 151**Mask**, 85

- define, 129

mask segment, 152**mass BOM change**, 152**master company**, 152**material**, 152**MBC**, 152**multicompany**, 152**multilevel bill of material**, 153**Multiples**

- multiples, 35

offsetting, 153**operation**, 153**option combination**, 153**order controlled/Batch**, 153**order system**, 154**order type**, 154**parallel assembly operations**, 154**Parameter sessions**, 123**Parameters**

- parameters, 33

PBOM, 155**person hours**, 154**physical breakdown**, 154**physical location**, 154**planned offline date**, 154**Post-assembly operations**

- assembly control, 105

price variances, 155**Process Engineering**

- line segments, 37, 39, 40, 41, 43, 46, 48

- parameters, 37

Processing assembly orders, 80**Processing sales order (line)**, 106**process-triggered workflow**, 155**Procuring configured items in Assembly Control - Product Structure**, 110, 120**Procuring configured items in Assembly Control - Setting up Master Data**, 109**Product Configuration (PCF)**, 122**Product engineering - An Introduction**, 43**production BOM**, 155**production order**, 155**Production orders for assembly line**, 80**product model**, 155**product structure**, 155**Product Structure**

- assembly line structure, 33

- Assembly Line Structure, 37, 37, 39, 40, 41, 43, 46, 48, 49, 50, 57, 69, 71

product variant, 155**Product Variant**

- assembly, 35

Product variant - purchased configurable item

- compare variants, 112

Product variant purchase price structure, 112**Product variants in Warehousing**

- Product variants in Sales, To sell multiples of a product variant, 130

product variant structure, 156**project item**, 156**purchase schedule**, 156**reference type**, 156**refresh**

- Assembly Orders, 95

Refresh

- assembly orders, 95

requested offline date, 156**Review Line Station Orders**, 84**Review product variant**, 78**Review Product Variant**

- create sales order (line), 75, 84

revision, 157**revision-controlled**, 157**rework order**, 157**Rework orders**

- rework orders, 105

roll-off line, 157**routing**, 157**Rules**, 59**sales order lines**, 158**scrap**, 158**segment schedule**, 158**Sequence Assembly Orders**, 84**Sequencing**

- assembly orders, 59

serialized item, 158**Serialized item handling**

automatic, 88
manual, 88

Serialized item
handling, 88
Manufacturing, 85, 88
setup, 85
working, 88

serial number, 158

shop floor warehouse, 159

specification, 159

standard cost, 159

standard item, 159

Storing generic items
storing generic items, 123

subassembly, 160

supplying assembly line, 160

supply in line sequence, 160

Synchronizing a supply line with multiple parent lines
Assembly line selection - The Configuration
Dependent parameter, 28

time fence, 160

Transfers
WIP, 99

translation table, 160

Transportation Lead Time
linked assembly lines, 29, 90

Transportation Time
transportation lead time, 29, 90

Types
rule, 59

unit effective item, 160

unit effectivity, 161

Unit effectivity and EDM, 107

Unit effectivity
to set up, 108

upgrade price, 161

Validate Assembly Lines, 40, 41, 43
Create Operations, 46, 48

Variant
line station, 82

warehouse order, 161

warehousing order, 161

WIP transfer, 161

work center, 162

yield, 162
