



# Planning Application Host Administration Guide

Release 15.1.9.2

### **Important Notices**

The material contained in this publication (including any supplementary information) constitutes and contains confidential and proprietary information of Infor.

By gaining access to the attached, you acknowledge and agree that the material (including any modification, translation or adaptation of the material) and all copyright, trade secrets and all other right, title and interest therein, are the sole property of Infor and that you shall not gain right, title or interest in the material (including any modification, translation or adaptation of the material) by virtue of your review thereof other than the non-exclusive right to use the material solely in connection with and the furtherance of your license and use of software made available to your company from Infor pursuant to a separate agreement, the terms of which separate agreement shall govern your use of this material and all supplemental related materials ("Purpose").

In addition, by accessing the enclosed material, you acknowledge and agree that you are required to maintain such material in strict confidence and that your use of such material is limited to the Purpose described above. Although Infor has taken due care to ensure that the material included in this publication is accurate and complete, Infor cannot warrant that the information contained in this publication is complete, does not contain typographical or other errors, or will meet your specific requirements. As such, Infor does not assume and hereby disclaims all liability, consequential or otherwise, for any loss or damage to any person or entity which is caused by or relates to errors or omissions in this publication (including any supplementary information), whether such errors or omissions result from negligence, accident or any other cause.

Without limitation, U.S. export control laws and other applicable export and import laws govern your use of this material and you will neither export or re-export, directly or indirectly, this material nor any related materials or supplemental information in violation of such laws, or use such materials for any purpose prohibited by such laws.

### **Trademark Acknowledgements**

The word and design marks set forth herein are trademarks and/or registered trademarks of Infor and/or related affiliates and subsidiaries. All rights reserved. All other company, product, trade or service names referenced may be registered trademarks or trademarks of their respective owners.

### **Publication Information**

Release: Infor Fashion PLM 15.1.9.3

Publication Date: December 3, 2019

Document code: ifplm\_15.1.9.3\_ifplmag\_\_en-us

# Contents

- About this guide.....5**
  - Related documents.....6
- Contacting Infor.....7**
- Chapter 1: Understanding PAH concepts.....8**
  - PAH overview.....8
  - Installation.....8
  - Authorization.....9
    - Licensed modules and authorization.....10
    - Authorization features.....10
  - Authentication.....10
  - Diagnostic exception log.....11
    - Types of exception logs.....11
    - Types of exceptions.....11
  - Diagnostic program trace.....13
    - Frequency and volume of tracing.....13
    - Configuring the trace.....14
  - User profile management and application modules.....14
- Chapter 2: Working with Planning Application Host.....15**
  - Versions.....15
    - Managing versions.....15
    - Working with an active version.....15
  - Profiles.....16
    - Creating profiles.....16
    - Deleting a profile.....17
    - Changing profiles.....17
  - Actions.....17

---

Monitoring tasks.....	17
Handling messages.....	18
Closing panels.....	18
Preferences.....	19
Customizing language and fonts.....	19
Selecting a theme.....	19
Tools.....	20
Customizing layouts.....	20
Executing scripts.....	21
Viewing logs.....	21
Generating user log reports.....	22
<b>Chapter 3: Working with the Multi-User Administration module.....</b>	<b>23</b>
Managing roles.....	23
Create a role.....	23
Create active directory groups.....	24
Managing users.....	24
Create a user.....	25
Assign a profile to a user.....	26
Enable multi-user mode.....	26
Reset a user's password.....	26
Delete a user.....	26
Managing user sessions.....	27
End user session.....	27
Enable or disable login.....	27
Send notification.....	28
Managing version security.....	28
Define version access.....	28
<b>Chapter 4: Categories and authorities.....</b>	<b>29</b>
Available authorities in each licensed module.....	29

---

## About this guide

This document explains how to use Planning Application Host (PAH) by introducing you to key features and tasks, such as managing versions and users.

### Intended audience

This document is intended for system administrators who manage the configuration and multi-user administration of Infor Fashion PLM.

### Organization

To help you better understand PAH, this guide has been divided into the following parts:

Chapter	Description
Understanding PAH	Learn PAH concepts and basic features.
Working with PAH	Understand additional features that enhance the design and usability of PAH.
Working with the Multi-User Administration (MUA) module	Learn how to manage roles and users by using the MUA module.

You can use one of the following tips in reading this document:

- View the guide in sequence using the table of contents. Select the **Contents** tab, then click the plus box next to a book to see its contents. Click the title of each page to view the corresponding details in the right-hand pane.
- View the help in sequence by clicking **Next** at the top of the viewer. Click **Previous** to go backward.
- Find information using the online index. Click the **Index** tab, scroll through the keyword list, and double-click the keyword. When you double-click a keyword, the corresponding topic appears in the right-hand pane.
- Locate every occurrence of a word or phrase in the help. Click the **Search** tab and type the word. When the list of topics is displayed, double-click the topic title you want to display. The corresponding topic appears in the right-hand pane.

## Related documents

You can find these documents in the Infor Xtreme Support portal:

- *Infor Fashion PLM Planning Application Host Installation Guide*
- *Infor Fashion PLM Online Help*

## Contacting Infor

If you have questions about Infor products, go to Infor Concierge at <https://conciierge.infor.com/> and create a support incident.

If we update this document after the product release, we will post the new version on the Infor Support Portal. To access documentation, select **Search > Browse Documentation**. We recommend that you check this portal periodically for updated documentation.

If you have comments about Infor documentation, contact [documentation@infor.com](mailto:documentation@infor.com).

## Chapter 1: Understanding PAH concepts

Learn the concepts and requirements of the application.

### PAH overview

Planning Application Host (PAH) is a platform used to host one or more applications called licensed modules. You can perform these tasks with the PAH framework:

- Install and execute multiple instances of a module on the same machine  
PAH architecture provides the initial framework for a .NET smart client application, which can contain multiple planning modules and be made available as one common planning suite. An example is PAH with Infor Fashion PLM and Multi-User Administration Module (MUA). Another example is PAH with ARP and Single User Modules.
- Automate, to a certain extent, the maintenance of the database  
As applications, licensed modules need the support of a database to function. To address this need, PAH enables you to create and manage database versions of each licensed module. This function is conceptually similar to creating application versions.
- Work with several copies or versions of a database  
PAH enables users to work with several database versions and to copy a version as a new version. Using the Version Manager features, PAH can create, upgrade, and copy databases for each application it hosts.

### Installation

PAH Framework is installed using Infor Deployment Manager. The diagram illustrates how Deployment Manager is essential for PAH installation.

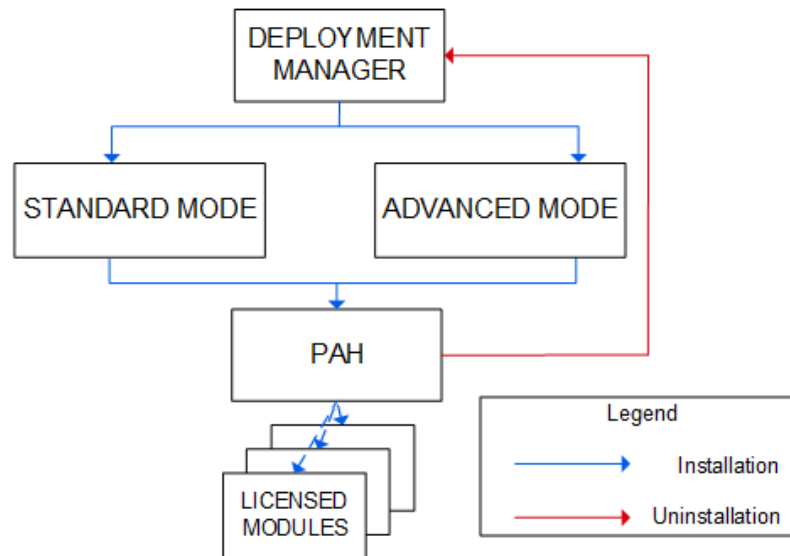

Deployment Manager is also used to install, update, and manage the publication of PAH and other application modules. You can install PAH by using the Deployment Manager in any of these two modes:

- Standard mode  
Installs the application in single user mode, and creates a local database.
- Advanced mode  
Installs, updates, and manages publishing of PAH and licensed modules.

See the *Infor Fashion PLM Planning Application Host Installation Guide*.

## Authorization

Authorization is the process of determining if a user or a user profile can perform a specific activity. Authorization has four entities:

- User  
Maps to a Windows user account, and forms a bridge between the Windows user and PAH user.
- Authority  
Represents a Boolean state that indicates if the user has rights to perform a specific task. This entity is the lowest unit of authorization.
- Role  
Maps to a real-world model and consists of one or more authorities. The mapped roles of authorities define the privileges for a user.
- User profile

Groups roles for a user by offering an abstraction layer. A user may be mapped to one or more profiles, and each profile may be mapped to one or more roles. This enables the user to choose among various assigned profiles.

## Licensed modules and authorization

A licensed module is an application that is launched using PAH. PAH hosts a licensed module and provides some core services to it, such as Authorization and Version Management. Each licensed module is expected to bring with it a set of authorities that may be mapped to one or more roles. When a licensed module is installed, all the authorities of that module are available in the licensed module database (LMD) file.

## Authorization features

- Multi-User Administration Module (MUA)  
The MUA feature enables the user to create and work with multiple user profiles. It imposes no restrictions on the creation of multiple roles and to what authorities they are mapped to.
- Navigation  
Each licensed module has the ability to specify the navigation tree that it requires.

## Authentication

Authentication is the process of identifying the credentials of a user. Authentication ensures that users who cannot be identified are denied access to the system.

Users are authenticated by accessing the central database server. This makes a network and access to the database server critical to authentication. If the network is unavailable, or if access to the database is restricted, the users cannot be authenticated.

By default, the authentication mode of Infor Fashion PLM is set to Windows authentication. This mode uses Active Directory Integration, which means, a user name and a password is not required to access the application. If you disable Active Directory Integration, a user name and password is required to access the application.

See [Managing roles](#) on page 23.

See [Managing users](#) on page 24.

## Diagnostic exception log

Diagnostic exception log records PAH exceptions for diagnostic purposes. PAH uses two methods to capture and process all exceptions:

- **Global exception handlers**  
PAH has a global exception handling mechanism that captures any unhandled exception occurring within the application. This mechanism acts as a safety net to ensure that all exceptions get captured and processed successfully.
- **Local exception handlers**  
PAH has localized exception handling blocks positioned at sections where the risk of encountering an exception is relatively higher. These blocks guard against certain known exceptions that might occur and handle them appropriately. This level of exception handling helps the application identify, track down, and process known exceptions in a better way.

## Types of exception logs

Once an exception is caught by a handler, a centralized logging mechanism logs the details pertaining to the exception, along with the date and time of its occurrence. This information is maintained in an exception log. An exception log can be configured to log exceptions to one or more log sources, such as the Windows event log, a text file, an XML file, and the database. PAH maintains two types of exception logs:

- **Default log**  
The default log acts as a central repository for all exceptions. All exceptions are logged to the application's default log. This log is maintained in a standard text file. This setting cannot be modified, but the user can choose to add more default log sources through the XML configuration file. This means that the default log can be configured to write exceptions to the text file and the Windows event log.
- **Crash log**  
The crash log is used to log exceptions that have a high level of impact. This log captures all exceptions that require immediate attention. By default, this log is configured to be maintained in the Windows event log. The log can be reconfigured through the XML file to log to any source as required.

## Types of exceptions

When an exception occurs, a message box that contains a description of the exception is displayed. The contents and design of the message box may vary, based on the type of exception that occurs. All exceptions occurring in PAH can be broadly classified into these types:

- 1 Expected exceptions

An exception that can occur under certain scenarios is called an expected exception. The application is aware of these scenarios and will have logic to handle these exceptions appropriately by catching them locally. All expected functional exceptions are assigned a low severity level. Expected exceptions can be classified as:

- Functional exceptions

This type of exception is thrown to serve a useful purpose. Such exceptions are intentionally introduced in various parts of the application to ensure user data validity and to enforce certain business rules and constraints. Examples include invalid data, business rule violations, and security or access-related exceptions.

- Nonfunctional exceptions

This type of exception does not serve a useful purpose and hinders the application flow. They occur unintentionally due to prevailing environmental conditions. The application is aware of the nonfunctional exception and can try to recover from it, but it may not always be able to advise the user on what exactly needs to be done to fix the problem. Certain expected, nonfunctional exceptions are considered critical if the application cannot fully recover from them. These are examples of expected, nonfunctional exceptions:

- Network problems that leads to failure of database operations
- Failure of database operations due to locked records
- Attachment files that cannot be found

## 2 Unexpected exceptions

Exceptions that occur unexpectedly and are caught by the application's default exception handling mechanism fall under this category. The application is not inherently aware of the causes of such exceptions and will need the help of an application administrator or developer to resolve them.

These are examples of unexpected exceptions:

- Unable to connect to the server
- Unable to access a component
- Exceptions arising from application defects

All unexpected exceptions are assigned a severity level of critical.

The Notify Administrator option available on the exception dialog box generates a new mail message using the user's default email client. This mail message is preloaded with the administrator's email ID and also has the details of the exception included inline. Additionally, the mail body has a section titled "Steps to replicate," and the user can choose to fill in the details of how the exception was encountered. Finally, the user can choose to include additional recipients and then send out the mail.

The Copy option that is also available on the exception dialog box enables the user to generate a .zip folder that contains the error log. The application settings and SCAH settings are also created in the .zip folder and are both generated in XML format. The user can then paste the compressed files in any folder in their computer. These files can be used to identify the exception error.

## Diagnostic program trace

Diagnostic Program Tracing is the process of finding out what is going on as a program executes, without interfering with the normal operation of the program. To achieve this, PAH provides:

### 1 Logging trace messages

PAH has a built-in mechanism to log trace messages. The application will have a centralized logging mechanism in place, which will facilitate the logging of trace messages. The application can define one or more loggers, and the trace data will be written to each of the configured loggers. By default, these built-in loggers will be available within the framework:

- Text file logger  
The trace information will be maintained in a trace log. Users can configure the path to the trace log.
- Windows event logger  
The trace information is maintained in the windows event log. Users have the option to turn on logging on either or both loggers.

### 2 Classification of trace messages

The program should have a means by which trace messages can be classified into meaningful groups. This enables the users to easily manage the group of functions they want to trace, rather than just tracing all messages. Messages being logged to the trace can be classified as Errors, Warnings, System Settings, Application Configuration Settings, Execution Path, Database Calls, and Data.

## Frequency and volume of tracing

You can use the tracing infrastructure to trace all events and data, but doing so could have a serious impact on the application's performance. Identifying relevant data becomes difficult if too much data is captured. Not enough data, on the other hand, is too abstract to be helpful and might result in loss of useful information. To balance between these extremes and prioritize the messages, PAH ensures that these activities are accomplished:

- Trace data is verified to be important and useful.
- Additional tracing is enabled in sections with relatively higher levels of functional complexity or business logic.
- Additional tracing is enabled in sections where the application interacts with external interfaces or components.
- Key milestones are traced in the execution path of the application.

## Configuring the trace

PAH provides the user with a facility to configure the tracing mechanism dynamically. This option is available in the Deployment Manager. By selecting this option, the user can trace parameters such as location of log files and level of trace elements to be included in the trace.

## User profile management and application modules

You can add new users to a user profile and update. You can also update application modules to upgrade modules within PAH. A user will update a module because of one or both of these reasons:

- Bug fixes
- Enhancements

Users can access licensed modules on a per profile basis. Some organizations may want to provide each user with several profiles.

See [Managing users](#) on page 24.

## Chapter 2: Working with Planning Application Host

Learn Planning Application Host (PAH) features that enhance the design and usability of PAH.

### Versions

A version is a copy of a database that is identified by a name. Conceptually, this may be thought of as a file name. PAH enables the user to work with several copies or versions of a database, including the ability to copy a version as a new version. The Version Manager has the ability to create several versions with each version being identified by a name.

### Managing versions

- 1 In Infor Fashion PLM, select **Admin > Manage Version**.
- 2 In the Manage Version dialog box, select Infor Fashion PLM from the list of licensed modules and click **Activate**. The selected module must be active and displayed in the list of active modules. The active module will have these details:
  - Name
  - Description
  - Version
  - Locked
  - Synchronization

### Working with an active version

Use these options to work with an active licensed module:

- Create
- Rename selected version
- Copy
- Mark for Deletion
- Unmark Delete

- Delete
- Lock version
- Close for Synchronization
- Import Version
- Export Version

See the *Infor Fashion PLM Online Help*.

## Profiles

A user is a PAH or a licensed module user who interacts with the system to perform a set of actions. A user is also mapped to a Windows user account, forming a bridge between the standard Windows user and a PAH user.

A user profile is an abstraction layer that provides the ability to group roles. A user may be mapped to one or more profiles, and each profile may be mapped to one or more Roles. This gives the User the ability to choose between the various profiles that has been assigned to the user account. User actions are granted or denied access based on the users' associated profile, roles, and authorities.

**Note:** Only one profile is created by default and is displayed as the default profile on the status bar.

## Creating profiles

Before creating a profile, ensure that you have created users and roles. A profile can be defined only in the context of a user, while roles define the authorities that can be mapped to a profile.

- 1 In Infor Fashion PLM, select **Admin > Manage Users**.
- 2 Select a user from the list and click **Edit**.
- 3 In the Assigned Profiles section, click **New**.
- 4 In the Add/Edit Profile window, specify this information:
  - Profile Name**  
Specify a name for the profile.
  - Description**  
Specify details about the role.
  - Select Work Method**  
Select a work method from the list.
- 5 To assign roles to a profile, select a role from the Available Roles list and click **>** to move it to the Selected Roles list.
- 6 Click **Save and Close** to save the profile and close the window.
- 7 Click **Save and New** to save the profile and create a new profile.
- 8 To exit the window without saving the profile, click **Close**.

## Deleting a profile

You can only delete profiles that are not yet assigned to users.

- 1 In Infor Fashion PLM, select **Admin > Manage Users**.
- 2 Select a user from the list and click **Edit**.
- 3 In the Assign Profiles section under Available Profiles, select the profile and click **Delete**.

## Changing profiles

Before changing profiles, ensure the user has more than one defined profile.

See [Creating profiles](#) on page 16.

- 1 In Infor Fashion PLM, select **Admin > Manage Users**.
- 2 On the Manage Users panel, click **Enable Multi-User Mode**.
- 3 A message confirming the switch to Multi-User Mode is displayed. Click **OK**.
- 4 Restart the application.
- 5 Select the new profile from the list.

**Note:** To switch back to Single User Mode, open Infor Deployment Manager and click **Update User Information**.

See the *Infor Fashion PLM Planning Application Host Installation Guide*.

## Actions

PAH provides these features to enhance the usability of Infor Fashion PLM:

- Monitoring tasks
- Handling messages
- Closing panels

## Monitoring tasks

Some features in Infor Fashion PLM require you to execute tasks to process the planning data. Such tasks are referred to as user-initiated tasks, and are executed locally on the same computer or on a remote server.

Infor Fashion PLM manages user-initiated tasks as foreground tasks or background tasks:

- Foreground task  
This task must be completed before starting another task.

- **Background task**

A background task is executed either in a local server or a remote server in the background without affecting other tasks that the user is executing. This task can be scheduled to run immediately or at a later date and time. A background task executed locally is not continuous and will be terminated if the machine is shut down. However, a background task scheduled on a remote server runs continuously until the task is complete.

The status of the background task is observed by launching the task monitor. A task monitor is a utility built into PAH that uses Windows services to monitor user-initiated background tasks. To launch the task monitor, select **Actions > Task Monitor** on the main menu.

## Handling messages

You can record messages of background tasks executed in Infor Fashion PLM.

### Record messages

- 1 In Infor Fashion PLM, select **Admin > Configure - Planning Application Host**.
- 2 In the Planning Application Host Settings dialog box, click **Messages**.
- 3 Specify the maximum number of messages that can be accumulated in each user profile. The number that you provide sets the limit to recorded messages. By default, the maximum value is 200.  
A value of 0 indicates no limit to recording messages and can cause message buildup and performance issues.
- 4 Click **Save**.

### View messages

- 1 In Infor Fashion PLM, select **Actions > Messages**.
- 2 On the Messages panel, select a licensed module from the list.
- 3 To view message details, double-click the message or click **Details**.
- 4 Click **Refresh** to update the list of messages.
- 5 Click **Delete** to delete a message.
- 6 Close the Message panel.

## Closing panels

PAH provides options on closing active and inactive panels immediately. This table shows the available options in closing the panels:

Option	Action
Close all panels	On the main menu, select <b>Actions &gt; Close All Panels</b> or press <b>Ctrl+Shift+A</b> .
Close an active panel	On the main menu, select <b>Actions &gt; Close Active Panel</b> or press <b>Ctrl+F4</b> .
Close inactive panels	On the main menu, select <b>Actions &gt; Close Inactive Panels</b> or press <b>Ctrl+Shift+W</b> .

## Preferences

The Preferences option enables the user to choose and set the language and fonts for PAH, as well as the color theme for Infor Fashion PLM.

## Customizing language and fonts

- 1 In Infor Fashion PLM, select **Admin > Preferences**.
- 2 In the Settings dialog window, click **Language and Fonts**.
  - To set the language:
    - a Select a language from the list of available languages.
    - b To reset the language to default application settings, click **Use Default**.
  - To set the fonts:
    - a Click the ellipsis button to set the fonts for Display Font 1, Display Font 2, and Data Font respectively.
    - b Select the font style and font size.
    - c To reset the font to default application settings, click **Use Default**.
- 3 Click **OK** then click **Save** to save changes.

## Selecting a theme

- 1 In Infor Fashion PLM, select **Admin > Preferences**.
- 2 On the Settings dialog window, click **Themes**.
- 3 Select Office White or Metropolis Dark.
- 4 To reset the theme to default application settings, click **Use Default**.
- 5 Click **Save**.
- 6 Restart Infor Fashion PLM for changes to take effect.

## Tools

To enable you to monitor performance and customize settings in Infor Fashion PLM, PAH provides these tools:

- Layouts
- Scripts
- Logs
- System information

## Customizing layouts

The Layout Designer enables you to configure layouts for the main modules of the application: Style, Material, and Trim. The customized layouts that you configure using the Layout Designer are available in the Layout pane.

To configure layouts, you must first define custom fields through the Field Designer. You can then design a layout for a module type, brand, and category.

## Define custom fields

- 1 In Infor Fashion PLM, select **Admin > Tools > Designer > Field Designer**.
- 2 On the Field Designer window, click **New**.
- 3 Specify this information:
  - Label**  
Specify a label name. The label serves as the field name.
  - Field Type**  
Select a field type from the list.
- 4 Click **Save**, then click **Close**.

## Define the layout

- 1 In Infor Fashion PLM, select **Admin > Tools > Designer > Layout Designer**.
- 2 On the Layout Designer window, select the **Edit Mode** check box.
- 3 Specify this information:
  - Module Type**  
(Required) Select Style, Material, or Trim.  
This field specifies the module type of the layout..

**Brand**

Select the brand that the layout will use.

**Category**

Select a product category.

- 4 Click **New**.
- 5 On the New Layout window, specify the layout name, and then click **OK**.
- 6 Click **Fields**.
- 7 Select available fields and click > to move them to the Used Fields box, and then click **OK**.
- 8 Hover to **Items** icon on the upper leftmost corner of the Layout Designer window to view the available fields and layout formats.
- 9 Drag and drop items to add them to the layout and use the tool bar to adjust the position, height, width, alignment, naming, and spacing of added fields in the layout.
- 10 Optionally, click **Set as Default** to make the layout available for other categories and brands in a module type without a defined layout.
- 11 Click **Save**.

## Executing scripts

Scripts are uncompiled codes that can be run by the users for PAH. The application reads, compiles, and executes these scripts for the users. Scripts can be used as a solution when certain factors in the application do not function properly, causing the application to fail or to not produce desired results. A script solution resides in a single file. You can deploy scripts by copying them to the application installation folder.

- 1 In Infor Fashion PLM, select **Admin > Tools > Script**.
- 2 On the Scripting dialog window, select a script from the list of files with .cs (script) extension displayed in the dialog window and click **Execute**.

Add-ins serve the purpose of extending or altering the functionality of the application without needing a full product shipment along with isolating the logic from the main application or product.

## Viewing logs

The Show Log option is used to display any exception that is caught by the system.

- 1 In Infor Fashion PLM, select **Admin > Tools > Show Log**.
- 2 Select a .log file from the list to view the details of the exception.

## Generating user log reports

You can generate user log reports to track the active users of the system.

**1** In Infor Fashion PLM, select **Admin > Tools > Generate User Log Report**.

User log summary report preview will open as a new window showing these details:

- **User Name**

This column shows the list of all users from the Manage Users module.

- **Name**

This column shows the names, which is a combination of first name and last name, of all the users who accessed the application.

- **Profile**

This column shows the profile name set by each user upon login.

- **Total Login**

This column shows the total number of times a user, per profile, logged into the application.

- **Last Login Date**

This column shows the last date and time a user, per profile, logged into the application.

**Note:** Last login date and time are based on your local machine's date and time settings.

- **Last Modified Date**

This column shows the last date and time a module record was modified by a user, per profile.

**Note:** Tracking of last modified date is limited to Style, Material, Trim, and Request records.

Last modified date is based on your local machine's date and time settings.

- **Last Modified Module**

This column shows the last module record that was modified by a user, per profile.

**Note:** Tracking of last modified module is limited to Style, Material, Trim, and Request records.

**2** Click the save icon to save a copy of the logs.

You may also click the print icon to print user log reports.

## Chapter 3: Working with the Multi-User Administration module

Learn how to use the Multi-User Administrator (MUA) module.

### Managing roles

Roles can be defined by one or many authorities in the system. By default, these roles are available in the application:

- Designer
- Technical Designer
- Product Specialist
- Material Coordinator
- Trim Specialist
- Merchandiser/Buyer

### Create a role

- 1 In Infor Fashion PLM, select **Admin > Manage Roles**.
- 2 On the Manage Roles panel, click **New**.
- 3 On the Add/Edit Roles dialog window, specify the relevant role details:

**Role Name**

(Required) Specify a name for your role.

**Description**

Specify a description for the role you are creating.

**Licensed Module**

(Required) Select Multi-User Administration, Infor Fashion PLM, or Fashion Application Host from the list.

The licensed module that you select determines the authorization you can assign to a role.

### Select Work Method

(Required) Select a work method from the list.

- 4 Assign authorities to the role by selecting from the Available Authorities list box and clicking **>**. See [Available authorities in each licensed module](#) on page 29 to know more about available authorities in the application.
- 5 Click **Save and Close**.
- 6 Optionally, click **Save and New** to save the changes and open a new Add/Edit Roles window.
- 7 Optionally, you can select any user role from the list and edit the same by clicking **Edit**.

## Create active directory groups

Before creating active directory groups, you must enable active directory integration through Deployment Manager.

See the *Infor Fashion PLM Planning Application Host Installation Guide*.

Users in active directory groups can access the application without having to be added as individual users under the Manage Users feature. An online profile is automatically generated and assigned to users that access the application.

- 1 In the Add/Edit Roles dialog window, click the **Active Directory Groups** tab.
- 2 Click **Add** to view a list of existing active directory groups.
- 3 Select active directory groups and click **OK**.
- 4 Click **Save and Close**.
- 5 Restart Infor Fashion PLM for changes to take effect.

**Note:** A user can only use one auto-generated or online profile, but one auto-generated or online profile may be used and shared by multiple users.

## Managing users

A user is essentially a Planning Application Host (PAH) or licensed module user who interacts with the system to perform actions. User actions are granted or denied based on the user's associated profile, roles, and authorities.

The administrator can perform these tasks by using the manage user functionality:

- Create a new user
- Edit a user
- Delete a user

When deleting a user, ownership of the user's information, such as the user's created records, user assignments, and other user fields, are transferred to the system user.

- Enable multiple users

The administrator can define any numbers of users, as well as view and modify all users in the system.

## Create a user

- 1 In Infor Fashion PLM, select **Admin > Manage Users**.
- 2 On the Manage Users panel, click **New**.
- 3 In the Save User window, specify this information:

### **Login Name**

Specify the login name.

### **User Name**

Specify the user name.

### **First Name**

Specify the first name of the user.

### **Last Name**

Specify the last name of the user.

### **Email**

Specify the e-mail address of the user.

### **Description**

Specify a short description.

### **Status**

Select active or inactive from the list.

**Note:** Inactive users are not allowed to log in on the application.

**Note:** By default, the authentication of Infor Fashion PLM is set to Windows Authentication. When you upgrade an existing Infor Fashion PLM installation and set, for the first time, the authentication to Basic Authentication, the passwords of all existing users in multi-user mode will be set to password. Upon initial sign in, all users in multi-user mode will be asked to change their passwords.

See “Set the authentication mode” in the *Infor Fashion PLM Planning Application Host Installation Guide*.

If the E-mail Settings of Infor Fashion PLM is set up and Basic Authentication is enabled, a newly created user will be assigned a random password that will be sent through email. If E-mail Settings is not set up and Basic Authentication is enabled, the default password for a newly created user is password. Upon initial sign in, the user will be asked to change the password.

See “Configuring email messages” in the *Infor Fashion PLM Online Help*.

## Assign a profile to a user

- 1 Select a user profile from the Assign Profiles list box and click **>**.  
You can create and edit a new profile using the New and Edit icons in the Assign Profiles list box. When the Add/Edit Profile dialog is displayed, apply the required changes.
- 2 Click **Save and Close** or **Save and New**.
- 3 Optionally, you can select and edit any user from the user list by clicking **Edit**.

## Enable multi-user mode

On the Manage Users panel, click **Enable Multi User Mode**.

**Note:** In multi-user mode, when Active Directory Integration is enabled, users under an Active Directory group that has been assigned a role in the Manage Roles module can access the application without being manually added in the Manage Users module of Infor Fashion PLM. An online profile is automatically generated and assigned to a user that accesses the application.

See [Managing users](#) on page 24.

## Reset a user's password

- 1 On the Manage Users panel, select a user.
- 2 Click **Reset Password**.
- 3 Upon initial sign in, change the password for added security.

**Note:** The Reset Password button is enabled only if the authentication mode is set to Basic Authentication.

See "Set the authentication mode" in the *Infor Fashion PLM Planning Application Host Installation Guide*.

## Delete a user

- 1 In Infor Fashion PLM, select **Admin > Manage Users**.
- 2 In the Manage Users panel, select a user account and click **Delete**.
- 3 In the confirmation dialog box, click **Yes**.

Once a user profile has been deleted in the system, the audit trail of the deleted user will be masked in the database. The host name and system user information of the records created or assigned to the deleted user are updated to default generalized names.

Host name is replaced with SYSTEM.

System user is replaced with SYSTEM USER.

## Managing user sessions

The Manage User Sessions module of Infor Fashion PLM allows you to control existing user connections to the application. The user sessions inside Infor Fashion PLM are maintained on a per profile basis.

**Note:** To receive notifications regarding user sessions, configure the messaging settings in Infor Fashion PLM.

See the *Infor Fashion PLM User Guide*.

- 1 From the main menu, select **Admin > Manage User Sessions**.
- 2 Select a user from the list and click the applicable action.

## End user session

- 1 Click **End User Session**.
- 2 Specify this information:

### **Title or Subject**

Specify a title or subject for your message.

### **Message Body**

Specify your message.

A notification is sent to the user containing the message that you specified in the Message Body field. You can configure the type of notification that the user will receive by configuring the messaging settings.

See the *Infor Fashion PLM User Guide*.

### **Disable User Login**

Select to disable user login.

- 3 Click **OK**.
- 4 Click **Yes** to confirm.

If the user encountered an error that closes the application, the user is still displayed as inactive in the user list. You must end the user session to clear the user status.

## Enable or disable login

- 1 Click **Enable Login** to enable user login.
- 2 Click **Disable Login** to disable user login.

## Send notification

You can use this action to notify the user before you end the session.

1 Select a user from the list and click **Send Notification**.

2 Specify this information:

### **Title or Subject**

Specify a title or subject for your message.

### **Message Body**

Type your message.

A notification is sent to the user containing the message that you specified in the Message Body field. You can configure the type of notification that the user will receive by configuring the messaging settings.

See the *Infor Fashion PLM User Guide*.

3 Click **OK**.

4 Click **Yes** to confirm.

## Managing version security

PAH provides version security by enabling you to define and manage the access of all user profiles in the application. Because a user may be mapped to one or more profiles, a user may have varying levels of access depending on the profile he is using.

## Define version access

Changes to version security are immediately applied to the application. Restarting the application is no longer needed.

1 In Infor Fashion PLM, select **Admin > Manage Version Security**.

2 In the Manage Version Security panel, select a user profile and click **Edit**.

3 In the Select Version dialog box, go to **User Details**.

4 Select an action to define the user's access to the application:

- Allow Full Access to all Versions
- Restrict to Versions Selected Below

5 To restrict access to selected versions, select a version from the Available Versions list and click **>** to move it to the Selected Versions list.

6 Click **Save and Close**.

## Chapter 4: Categories and authorities

### Available authorities in each licensed module

Available authorities can be classified into these categories:

- Full Control enables users to view, create, modify, and delete items in a module.
- Read Only enables users to view items in a module, but restricts them from creating, modifying, and deleting items.
- Read, Create and Update enables users to view, create, and modify items in a module.
- Delete enables users to view items in a module, but restricts them from creating and modifying items.

This table shows the available authorities in each licensed module:

Licensed module	Available authority
Multi-User Administration	Manage User (Full Control)
Multi-User Administration	Manage Roles (Full Control)
Multi-User Administration	Manage Version Security (Full Control)
Multi-User Administration	Manage User Sessions (Full Control)
Infor Fashion PLM	Style (Read Only)
Infor Fashion PLM	Style (Read, Create and Update)
Infor Fashion PLM	Style (Delete)
Infor Fashion PLM	Style (Archive)
Infor Fashion PLM	Style (Delete Attachment)
Infor Fashion PLM	Style Colorways (Read Only)
Infor Fashion PLM	Style Colorways (Read, Create and Update)
Infor Fashion PLM	Style Colorways (Delete)
Infor Fashion PLM	Style Colorways (On the fly)
Infor Fashion PLM	Style Overview 2 (Read Only)
Infor Fashion PLM	Style Overview 2 (Read, Create and Update)
Infor Fashion PLM	Style Overview 2 (Delete)

Licensed module	Available authority
Infor Fashion PLM	Style Sizes (Read Only)
Infor Fashion PLM	Style Sizes (Read, Create and Update)
Infor Fashion PLM	Style Sizes (Delete)
Infor Fashion PLM	Style BOM (Read Only)
Infor Fashion PLM	Style BOM (Read, Create and Update)
Infor Fashion PLM	Style BOM (Delete)
Infor Fashion PLM	Style BOM (On the fly)
Infor Fashion PLM	Style BOM (Delete Attachment)
Infor Fashion PLM	Style BOO (Read Only)
Infor Fashion PLM	Style BOO (Read, Create and Update)
Infor Fashion PLM	Style BOO (Delete)
Infor Fashion PLM	Style BOO (On the fly)
Infor Fashion PLM	Style Measurement (Read Only)
Infor Fashion PLM	Style Measurement (Read, Create and Update)
Infor Fashion PLM	Style Measurement (Delete)
Infor Fashion PLM	Style Measurement (On the fly)
Infor Fashion PLM	Style Pattern (Read Only)
Infor Fashion PLM	Style Pattern (Read, Create and Update)
Infor Fashion PLM	Style Pattern (Delete)
Infor Fashion PLM	Style Pattern (Delete Attachment)
Infor Fashion PLM	Style Marker (Read Only)
Infor Fashion PLM	Style Marker (Read, Create and Update)
Infor Fashion PLM	Style Marker (Delete)
Infor Fashion PLM	Style Marker (Delete Attachment)
Infor Fashion PLM	Style Images (Read Only)
Infor Fashion PLM	Style Images (Read, Create and Update)
Infor Fashion PLM	Style Images (Delete)
Infor Fashion PLM	Style Care & Content (Read Only)
Infor Fashion PLM	Style Care & Content (Read, Create and Update)
Infor Fashion PLM	Style Care & Content (Delete)
Infor Fashion PLM	Style Sourcing (Read Only)

Licensed module	Available authority
Infor Fashion PLM	Style Sourcing (Read, Create and Update)
Infor Fashion PLM	Style Sourcing (Delete)
Infor Fashion PLM	Style Costing (Read Only)
Infor Fashion PLM	Style Costing (Read, Create and Update)
Infor Fashion PLM	Style Costing (Delete)
Infor Fashion PLM	Style Costing (On the fly)
Infor Fashion PLM	Style Request (Read Only)
Infor Fashion PLM	Style Request (Read, Create and Update)
Infor Fashion PLM	Style Characteristic (Read Only)
Infor Fashion PLM	Style Characteristic (Read, Create and Update)
Infor Fashion PLM	Style Characteristic (Delete)
Infor Fashion PLM	Style Integration (Read Only)
Infor Fashion PLM	Style Integration (Read, Create and Update)
Infor Fashion PLM	Style History (Read Only)
Infor Fashion PLM	Style Variation (Read Only)
Infor Fashion PLM	Style Variation (Read, Create and Update)
Infor Fashion PLM	Style Comments (Read Only)
Infor Fashion PLM	Style Comments (Read, Create and Update)
Infor Fashion PLM	Style Comments (Delete)
Infor Fashion PLM	Style Comments (Delete Attachment)
Infor Fashion PLM	Style Compliance (Read Only)
Infor Fashion PLM	Style Compliance (Read, Create and Update)
Infor Fashion PLM	Style Compliance (Delete)
Infor Fashion PLM	Style Compliance (Delete Attachment)
Infor Fashion PLM	Style Follow Up (Read Only)
Infor Fashion PLM	Style Follow Up (Read, Create and Update)
Infor Fashion PLM	Style Follow Up (Delete)
Infor Fashion PLM	Style Additional Info (Read Only)
Infor Fashion PLM	Style Additional Info (Read, Create and Update)
Infor Fashion PLM	Style Module Designer (Read Only)
Infor Fashion PLM	Style Module Designer (Read, Create and Update)

Licensed module	Available authority
Infor Fashion PLM	Style Module Designer (Delete)
Infor Fashion PLM	Style Reports (Read Only)
Infor Fashion PLM	Style Reports (Read, Create and Update)
Infor Fashion PLM	Currency (Read Only)
Infor Fashion PLM	Currency (Full Control)
Infor Fashion PLM	Color (Read Only)
Infor Fashion PLM	Color (Full Control)
Infor Fashion PLM	Colorway Comments (Read, Create and Update)
Infor Fashion PLM	Colorway Comments (Read Only)
Infor Fashion PLM	Colorway Comments (Delete)
Infor Fashion PLM	Status (Read Only)
Infor Fashion PLM	Status (Full Control)
Infor Fashion PLM	Exchange Rate (Read Only)
Infor Fashion PLM	Exchange Rate (Full Control)
Infor Fashion PLM	Size (Read Only)
Infor Fashion PLM	Size (Full Control)
Infor Fashion PLM	Reports (Read Only)
Infor Fashion PLM	Reports (Full Control)
Infor Fashion PLM	Size Characteristics (Read Only)
Infor Fashion PLM	Size Characteristics (Read, Create and Update)
Infor Fashion PLM	Size Characteristics (Delete)
Infor Fashion PLM	Size Range (Read Only)
Infor Fashion PLM	Size Range (Full Control)
Infor Fashion PLM	Size Category (Read Only)
Infor Fashion PLM	Size Category (Full Control)
Infor Fashion PLM	Sourcing (Read Only)
Infor Fashion PLM	Sourcing (Full Control)
Infor Fashion PLM	Supplier Compliance Template (Read Only)
Infor Fashion PLM	Supplier Compliance Template (Full Control)
Infor Fashion PLM	Supplier Request (Read Only)
Infor Fashion PLM	Supplier Request (Full Control)

Licensed module	Available authority
Infor Fashion PLM	Generic Lookup (Read Only)
Infor Fashion PLM	Generic Lookup (Full Control)
Infor Fashion PLM	Generic Lookup Field Dependencies (Read Only)
Infor Fashion PLM	Generic Lookup Field Dependencies (Full Control)
Infor Fashion PLM	Manage Version (Read Only)
Infor Fashion PLM	Manage Version (Full Control)
Infor Fashion PLM	Trim (Read Only)
Infor Fashion PLM	Trim (Read, Create and Update)
Infor Fashion PLM	Trim (Delete)
Infor Fashion PLM	Trim (Archive)
Infor Fashion PLM	Trim (Delete Attachment)
Infor Fashion PLM	Trim Colorways (Read Only)
Infor Fashion PLM	Trim Colorways (Read, Create and Update)
Infor Fashion PLM	Trim Colorways (Delete)
Infor Fashion PLM	Trim Sizes (Read Only)
Infor Fashion PLM	Trim Sizes (Read, Create and Update)
Infor Fashion PLM	Trim Sizes (Delete)
Infor Fashion PLM	Trim Images (Read Only)
Infor Fashion PLM	Trim Images (Read, Create and Update)
Infor Fashion PLM	Trim Images (Delete)
Infor Fashion PLM	Trim Care (Read Only)
Infor Fashion PLM	Trim Care (Read, Create and Update)
Infor Fashion PLM	Trim Care (Delete)
Infor Fashion PLM	Trim Sourcing (Read Only)
Infor Fashion PLM	Trim Sourcing (Read, Create and Update)
Infor Fashion PLM	Trim Sourcing (Delete)
Infor Fashion PLM	Trim Characteristic (Read Only)
Infor Fashion PLM	Trim Characteristic (Read, Create and Update)
Infor Fashion PLM	Trim Characteristic (Delete)
Infor Fashion PLM	Trim Extra Details (Read Only)
Infor Fashion PLM	Trim Extra Details (Read, Create and Update)

Licensed module	Available authority
Infor Fashion PLM	Trim Where Used (Read Only)
Infor Fashion PLM	Trim Request (Read Only)
Infor Fashion PLM	Trim Request (Read, Create and Update)
Infor Fashion PLM	Trim Comments (Read Only)
Infor Fashion PLM	Trim Comments (Read, Create and Update)
Infor Fashion PLM	Trim Comments (Delete)
Infor Fashion PLM	Trim Comments (Delete Attachment)
Infor Fashion PLM	Trim Compliance (Read Only)
Infor Fashion PLM	Trim Compliance (Read, Create and Update)
Infor Fashion PLM	Trim Compliance (Delete)
Infor Fashion PLM	Trim Compliance (Delete Attachment)
Infor Fashion PLM	Trim Additional Info (Read Only)
Infor Fashion PLM	Trim Additional Info (Read, Create and Update)
Infor Fashion PLM	Trim Reports (Read Only)
Infor Fashion PLM	Trim Reports (Read, Create and Update)
Infor Fashion PLM	Trim Module Designer (Read Only)
Infor Fashion PLM	Trim Module Designer (Read, Create and Update))
Infor Fashion PLM	Trim Module Designer (Delete)
Infor Fashion PLM	Material (Read Only)
Infor Fashion PLM	Material (Read, Create and Update)
Infor Fashion PLM	Material (Delete)
Infor Fashion PLM	Material (Archive)
Infor Fashion PLM	Material (Delete Attachment)
Infor Fashion PLM	Material Colorways (Read Only)
Infor Fashion PLM	Material Colorways (Read, Create and Update)
Infor Fashion PLM	Material Colorways (Delete)
Infor Fashion PLM	Material Images (Read Only)
Infor Fashion PLM	Material Images (Read, Create and Update)
Infor Fashion PLM	Material Images (Delete)
Infor Fashion PLM	Material Care (Read Only)
Infor Fashion PLM	Material Care (Read, Create and Update)

Licensed module	Available authority
Infor Fashion PLM	Material Care (Delete)
Infor Fashion PLM	Material Sourcing (Read Only)
Infor Fashion PLM	Material Sourcing (Read, Create and Update)
Infor Fashion PLM	Material Sourcing (Delete)
Infor Fashion PLM	Material Request (Read Only)
Infor Fashion PLM	Material Request (Read, Create and Update)
Infor Fashion PLM	Material Characteristic (Read Only)
Infor Fashion PLM	Material Characteristic (Read, Create and Update)
Infor Fashion PLM	Material Characteristic (Delete)
Infor Fashion PLM	Material Construction (Read Only)
Infor Fashion PLM	Material Construction (Read, Create and Update)
Infor Fashion PLM	Material Where Used (Read Only)
Infor Fashion PLM	Material Comments (Read Only)
Infor Fashion PLM	Material Comments (Read, Create and Update)
Infor Fashion PLM	Material Comments (Delete)
Infor Fashion PLM	Material Comments (Delete Attachment)
Infor Fashion PLM	Material Compliance (Read Only)
Infor Fashion PLM	Material Compliance (Read, Create and Update)
Infor Fashion PLM	Material Compliance (Delete)
Infor Fashion PLM	Material Compliance (Delete Attachment)
Infor Fashion PLM	Material Additional Info (Read Only)
Infor Fashion PLM	Material Additional Info (Read, Create and Update)
Infor Fashion PLM	Material Reports (Read Only)
Infor Fashion PLM	Material Reports (Read, Create and Update)
Infor Fashion PLM	Material Module Designer (Read Only)
Infor Fashion PLM	Material Module Designer (Read, Create and Update)
Infor Fashion PLM	Material Module Designer (Delete)
Infor Fashion PLM	Pattern (Read Only)
Infor Fashion PLM	Pattern (Full Control)
Infor Fashion PLM	Point of Measure (Read Only)
Infor Fashion PLM	Point of Measure (Full Control)

Licensed module	Available authority
Infor Fashion PLM	Grade Rule (Read Only)
Infor Fashion PLM	Grade Rule (Full Control)
Infor Fashion PLM	Item Type (Read Only)
Infor Fashion PLM	Item Type (Full Control)
Infor Fashion PLM	Color Palette (Read Only)
Infor Fashion PLM	Color Palette (Full Control)
Infor Fashion PLM	Care (Read Only)
Infor Fashion PLM	Care (Full Control)
Infor Fashion PLM	Style Mass Create
Infor Fashion PLM	Style Mass Update
Infor Fashion PLM	Material Mass Create
Infor Fashion PLM	Material Mass Update
Infor Fashion PLM	Trim Mass Create
Infor Fashion PLM	Trim Mass Update
Infor Fashion PLM	Characteristic (Read Only)
Infor Fashion PLM	Characteristic (Full Control)
Infor Fashion PLM	Test (Read Only)
Infor Fashion PLM	Test (Full Control)
Infor Fashion PLM	Standard (Read Only)
Infor Fashion PLM	Standard (Full Control)
Infor Fashion PLM	Request (Read Only)
Infor Fashion PLM	Request (Full Control)
Infor Fashion PLM	Request Comments (Read, Create and Update)
Infor Fashion PLM	Request Comments (Read Only)
Infor Fashion PLM	Request Comments (Delete)
Infor Fashion PLM	Organizational Structure (Read Only)
Infor Fashion PLM	Organizational Structure (Full Control)
Infor Fashion PLM	Activity (Read Only)
Infor Fashion PLM	Activity (Full Control)
Infor Fashion PLM	Activity List (Read Only)
Infor Fashion PLM	Activity List (Full Control)

Licensed module	Available authority
Infor Fashion PLM	Milestone (Read Only)
Infor Fashion PLM	Milestone (Full Control)
Infor Fashion PLM	Critical Path (Read Only)
Infor Fashion PLM	Critical Path (Full Control)
Infor Fashion PLM	UOM Conversion (Read Only)
Infor Fashion PLM	UOM Conversion (Full Control)
Infor Fashion PLM	Cost Element (Read Only)
Infor Fashion PLM	Cost Element (Full Control)
Infor Fashion PLM	Cost Model (Read Only)
Infor Fashion PLM	Cost Model (Full Control)
Infor Fashion PLM	Dictionary (Read Only)
Infor Fashion PLM	Dictionary (Full Control)
Infor Fashion PLM	Operation (Read Only)
Infor Fashion PLM	Operation (Full Control)
Infor Fashion PLM	Operation List (Read Only)
Infor Fashion PLM	Operation List (Full Control)
Infor Fashion PLM	Collection Plan (Read Only)
Infor Fashion PLM	Collection Plan (Full Control)
Infor Fashion PLM	Line Plan (Read Only)
Infor Fashion PLM	Line Plan (Full Control)
Infor Fashion PLM	Fashion PLM Settings - Attachments Settings (Full Control)
Infor Fashion PLM	Fashion PLM Settings - Organization Settings (Full Control)
Infor Fashion PLM	Fashion PLM Settings - Color Settings (Full Control)
Infor Fashion PLM	Fashion PLM Settings - Critical Path (Full Control)
Infor Fashion PLM	Fashion PLM Settings - Data Filtering (Full Control)
Infor Fashion PLM	Fashion PLM Settings - Date and Time Settings (Full Control)
Infor Fashion PLM	Fashion PLM Settings - E-Mail Settings (Full Control)
Infor Fashion PLM	Fashion PLM Settings - History Settings (Full Control)

Licensed module	Available authority
Infor Fashion PLM	Fashion PLM Settings - Locked Record Settings (Full Control)
Infor Fashion PLM	Fashion PLM Settings - Load Grid Settings (Full Control)
Infor Fashion PLM	Fashion PLM Settings - Field Length Limit (Full Control)
Infor Fashion PLM	Fashion PLM Settings - Mass Create/Mass Update Settings (Full Control)
Infor Fashion PLM	Fashion PLM Settings - Tab Details (Full Control)
Infor Fashion PLM	Fashion PLM Settings - Care & Content Settings (Full Control)
Infor Fashion PLM	Fashion PLM Settings - Request Tag Settings (Full Control)
Infor Fashion PLM	Fashion PLM Settings - Request Ownership Settings (Full Control)
Infor Fashion PLM	Fashion PLM Settings -Messaging Settings (Full Control)
Infor Fashion PLM	Fashion PLM Settings - Style SKU Settings (Full Control)
Infor Fashion PLM	Fashion PLM Settings - Partner Collaboration Settings (Full Control)
Infor Fashion PLM	Fashion PLM Settings - BOM Details Update Settings (Full Control)
Infor Fashion PLM	Fashion PLM Settings - Style Measurement Settings (Full Control)
Infor Fashion PLM	Fashion PLM Settings - Pattern / Marker Settings (Full Control)
Infor Fashion PLM	Item Type (Read Only)
Infor Fashion PLM	Item Type (Full Control)
Infor Fashion PLM	Purchase Order (Read Only)
Infor Fashion PLM	Purchase Order (Full Control)
Infor Fashion PLM	Manage Version (Read Only)
Infor Fashion PLM	Manage Version Records (Full Control)
Infor Fashion PLM	Manage Deleted Records (Read Only)
Infor Fashion PLM	Manage Deleted Records (Full Control)

Licensed module	Available authority
Infor Fashion PLM	Manage Archived (Read Only)
Infor Fashion PLM	Manage Archived Records (Full Control)
Infor Fashion PLM	Manage Locked Records (Read Only)
Infor Fashion PLM	Manage Locked Records (Full Control)
Infor Fashion PLM	Manage Partner Collaboration (Read Only)
Infor Fashion PLM	Manage Partner Collaboration (Full Control)
Infor Fashion PLM	Manage Merchandise Planning (Read Only)
Infor Fashion PLM	Manage Merchandise Planning (Full Control)
Infor Fashion PLM	ID Generator (Read Only)
Infor Fashion PLM	ID Generator (Full Control)
Planning Application Host	Clear All Completed Tasks (Full Control)
Planning Application Host	Extract License Audit Trail (Full Control)
Planning Application Host	Report Generate Logs (Full Control)
Planning Application Host	Generate System Information (Full Control)
Planning Application Host	ID Generation (Full Control)
Planning Application Host	Update Settings (Full Control)
Planning Application Host	Field and Layout Designer (Full Control)
Planning Application Host	Scripts (Full Control)
Planning Application Host	Show Log (Full Control)
Planning Application Host	Show Trace (Full Control)