



Infor CloudSuite Business Multi-Site Planning Guide

Release 9.01.x

Copyright © 2017 Infor

Important Notices

The material contained in this publication (including any supplementary information) constitutes and contains confidential and proprietary information of Infor.

By gaining access to the attached, you acknowledge and agree that the material (including any modification, translation or adaptation of the material) and all copyright, trade secrets and all other right, title and interest therein, are the sole property of Infor and that you shall not gain right, title or interest in the material (including any modification, translation or adaptation of the material) by virtue of your review thereof other than the non-exclusive right to use the material solely in connection with and the furtherance of your license and use of software made available to your company from Infor pursuant to a separate agreement, the terms of which separate agreement shall govern your use of this material and all supplemental related materials ("Purpose").

In addition, by accessing the enclosed material, you acknowledge and agree that you are required to maintain such material in strict confidence and that your use of such material is limited to the Purpose described above. Although Infor has taken due care to ensure that the material included in this publication is accurate and complete, Infor cannot warrant that the information contained in this publication is complete, does not contain typographical or other errors, or will meet your specific requirements. As such, Infor does not assume and hereby disclaims all liability, consequential or otherwise, for any loss or damage to any person or entity which is caused by or relates to errors or omissions in this publication (including any supplementary information), whether such errors or omissions result from negligence, accident or any other cause.

Without limitation, U.S. export control laws and other applicable export and import laws govern your use of this material and you will neither export or re-export, directly or indirectly, this material nor any related materials or supplemental information in violation of such laws, or use such materials for any purpose prohibited by such laws.

Trademark Acknowledgements

The word and design marks set forth herein are trademarks and/or registered trademarks of Infor and/or related affiliates and subsidiaries. All rights reserved. All other company, product, trade or service names referenced may be registered trademarks or trademarks of their respective owners.

Publication Information

Release: Infor Cloudsuite Business (Industrial) 9.01.x

Publication Date: July 21, 2017

Document code: csbi_9.01.x_csbimspcg_op_csbus_en-us

Contents

About this guide.....	9
Resulting tools.....	9
Planning worksheet.....	10
Contacting Infor.....	13
Chapter 1: Determining your corporate structure.....	15
Creating a flowchart that shows your hierarchy.....	15
Creating a SiteEntity spreadsheet.....	16
Background information.....	17
Company hierarchies.....	18
Chapter 2: Multi-site vs. multi-warehouse.....	19
Multi-site considerations.....	19
Deciding whether you need multi-site.....	20
Background information.....	20
Financial considerations.....	20
Manufacturing considerations.....	23
Payroll/Human Resources considerations.....	24
Operations considerations.....	25
Administration/technical requirements considerations.....	28
Warehouses overview.....	28
Chapter 3: Multi-site per database vs. one site per database.....	35
Deciding whether you need multiple sites in one database.....	37
Background information.....	38
Chapter 4: Entities.....	41
Updating the flowchart.....	41
Updating the SiteEntity spreadsheet.....	42
Background information.....	42
Entities overview.....	42
Sites that report to an entity.....	42
Setup of entities and the reporting structure.....	43
Multiple currencies and consolidation.....	44
Combined vs. consolidated reporting.....	44
Chapter 5: Number of sites that are required.....	45

Considerations.....	45
Updating the flowchart.....	46
Creating a list of currency codes.....	46
Updating the SiteEntity spreadsheet.....	47
Background information.....	47
Material transfers between sites.....	47
Centralized and decentralized order entry.....	50
Functions where entity data is not available.....	52
Using multiple currencies.....	52
Physical requirements.....	54
Chapter 6: Using the same forms database for multiple sites.....	55
Updating the SiteEntity spreadsheet.....	56
Background information.....	56
Chapter 7: Using the same objects database for multiple sites.....	57
Considerations.....	57
Updating the SiteEntity spreadsheet.....	58
Background information.....	58
Chapter 8: Grouping sites.....	59
Example.....	59
Creating a list of potential groups.....	60
Updating the SiteEntity spreadsheet.....	60
Background information.....	60
Chapter 9: Intranets.....	63
Considerations.....	63
Reviewing your physical requirements.....	64
Updating the SiteEntity spreadsheet.....	64
Background information.....	65
About intranets.....	65
Sending or receiving Business Object Documents from multiple sites on an intranet.....	66
TaskMan monitoring of sites.....	66
Chapter 10: Web rendering.....	69
Considerations.....	69
Actions.....	70
Chapter 11: Grouping and managing configurations.....	71
Considerations.....	71
Adding configuration names and groups to a spreadsheet.....	71

Determining the configuration groups that you need.....	72
Determining which server is the configuration server.....	72
Background information.....	72
Configuration names.....	72
Configuration server.....	73
Configuration groups.....	74
Chapter 12: Sharing data between sites.....	77
Considerations.....	77
Updating the flowchart.....	77
Creating a ReplicationRules spreadsheet.....	78
Background information.....	78
Replication with multiple sites per database.....	78
Default replication categories.....	78
Replicating Site Admin.....	82
Replicating A/P and A/R.....	82
Replicating multi-site information for Home forms.....	83
Replicating Manufacturer Item.....	83
Replicating Centralized Order Entry and Inventory/Transfers.....	83
Sharing vendors, customers, or items between sites.....	84
Replicating financial information.....	86
Replicating dimensions.....	88
Replicating shared currency.....	88
Replicating planned transfer orders (Planning).....	89
Replicating external financial (EXTFIN) data.....	90
Initializing parameter table data.....	91
Replicating Invoice Builder data.....	91
Replicating Journal Builder data.....	92
Replicating Purchase Order Builder data.....	92
Replicating Voucher Builder data.....	93
Replicating Customer and Vendor Portal data.....	94
Replicating Service data.....	94
Replicating data via BODs (ESB).....	95
Recommended transactional replication rules.....	95
Chapter 13: Sharing some data through master sites.....	97
Considerations.....	97
Updating the flowchart.....	98
Creating a list of the tables or categories controlled by the master site.....	99
Updating the SiteEntity spreadsheet.....	99
Updating the ReplicationRules spreadsheet.....	99
Background information.....	100

Intranets with shared tables and master sites.....	100
Shared _all tables.....	100
Shared user tables.....	100
Frequently asked questions about shared tables and master sites.....	101
Maintaining customer, vendor or item data for other sites in the intranet.....	104
Chapter 14: Frequency of data replication.....	107
Update the ReplicationRules spreadsheet.....	107
Background information.....	107
Replication Rules form.....	108
Chapter 15: Using the Application Event System.....	111
Actions.....	111
Background information.....	111
Monitoring events.....	112
Chapter 16: Add-on products and modules.....	115
Updating the flowchart and spreadsheets.....	115
Background information.....	115
APS.....	115
Analytics.....	118
Country packs and localizations.....	119
CPM.....	119
Credit Card Interface.....	119
DataViews and Critical Numbers.....	120
EDI.....	120
Enterprise Financials (SLSI).....	120
Microsoft Excel add-in.....	121
Factory Track.....	122
Global Financials (Varial).....	122
BOD-enabled applications (ION).....	123
Industry packs.....	123
Infor Local.ly.....	123
Mobile.....	123
Office Application Search Service.....	124
Outlook.....	124
Configure Price Quote (CPQ).....	124
PLM.....	125
PLM Accelerate.....	125
Portals.....	125
SCE Warehouse Management (WM) module.....	127
Service.....	127

Chapter 17: Licensing	129
Considerations.....	129
Creating a License spreadsheet.....	130
Background information.....	130
Chapter 18: Naming rules	131
Considerations.....	131
Updating the flowchart and spreadsheets.....	132
Determining prefix use for records in different sites.....	132
Background information.....	132
Prefixes.....	132
Item numbers.....	134
Chapter 19: Incorporating later changes	135
Revising your flowcharts and spreadsheets.....	135
Background information.....	135
Changes to your reporting structure.....	135
Appendix A: Replication overview	137
About replication.....	137
_all tables.....	138
Replication categories and rules.....	140
Using categories with rules.....	140
Point to point replication.....	141
Intranets.....	142
Transport protocol.....	143
Master sites and shared tables.....	143
Multiple sites in one database.....	143
Replicating _all tables.....	143
Replicating base tables.....	144
Replicating shared tables.....	144
Appendix B: Replication category tables	145
A/P category.....	145
A/R category.....	147
CCI Centralized Order Entry category.....	149
Centralized Order Entry category.....	149
Customer Portal category.....	153
Dimensions category.....	154
ESB category.....	154
EXTFIN category.....	155

Contents

EXTFIN Customer category.....	156
EXTFIN Vendor category.....	156
G/L category.....	156
Initialize _All Parameters category.....	159
Inventory/Transfers category.....	159
Invoice Builder category.....	162
Journal Builder category.....	163
Ledger Consolidation category.....	164
Ledger Detail category.....	165
Manufacturer Item category.....	166
Multi-Site Home form categories.....	166
Multi-Site BOM Builder category.....	166
Multi-Site Customers category.....	167
Multi-Site Items category.....	167
Planning category.....	168
PO - CO - Across Sites category.....	169
Purchase Order Builder category.....	170
Service - Global Incidents category.....	171
Service - Global Scheduling Shared Partners category.....	172
Service - Global Service History category.....	172
Service - Global Units category.....	173
Service - Multi-Site SRO Copy category.....	173
Shared Currency category.....	174
Site Admin category.....	174
Vendor Portal category.....	175
Voucher Builder category.....	175
Glossary.....	177

About this guide

Use this guide to plan for a multi-site installation of Infor CloudSuite Business. When you have multiple sites, the installation and configuration of your system becomes much more complex. If you answer the questions in this guide before you begin installation, you will be prepared, and your installation and configuration should go more smoothly.

This guide has these sections:

- Planning worksheet: Lists the questions, in order, that you should ask and answer when planning your system. Each step lists one or more tasks that must be completed while answering the question.
- Chapters that perform these functions:
 - Address each of the questions from the planning worksheet
 - List the planning tasks you must perform to answer the questions
 - Provide background information that helps you complete the planning tasks
- Glossary: Defines CloudSuite Business and industry-specific terms used in this guide

Resulting tools

After you complete the planning tasks, you should have these tools:

- A flowchart showing all of the sites and entities in your logical/financial hierarchy, and the shared data relationships between them
- A `SiteEntity` spreadsheet that lists, for each site, most of the information required for installation, such as site name, type, database names, site group, intranet name, and so on
- A `ReplicationRules` spreadsheet that lists each of the rules that is required to replicate data between the sites
- An `Events` spreadsheet listing the configurations to be monitored by the Application Event System
- A `Licensing` spreadsheet that lists each license module (along with the number of users) needed for each site
- A `Configurations` spreadsheet, if you have multiple configurations per application database, that lists the configuration names, groups, and the related databases
- A list of your planned currency codes

- Lists of your planned site groups and master site tables

Use these tools, along with the *Infor CloudSuite Business Multi-Site Implementation Guide* and the *Infor CloudSuite Business Installation Guide*, to install and set up your system. Keep the information in the spreadsheets up to date, to use for reference as your system changes.

Samples of these tools are available in a ZIP file in the Documentation area on the Infor Xtreme support site.

Planning worksheet

Use this worksheet to determine the questions to ask and the tasks that must be completed before you start installing your system. The questions are addressed in more detail, with information to help you answer them, in the chapters of this guide.

Step	Question	Tasks
1	What is your corporate structure? What hierarchical structure is required for financial reporting, for sharing of data and for transfer of materials?	<ol style="list-style-type: none">1 Draw a preliminary flowchart in pencil or using a computer modeling tool like Visio®. You will probably change the flowchart several times.2 Create a <code>SiteEntity</code> spreadsheet containing a preliminary list of the site names and types.
2	Multi-site or multi-warehouse? Understand the differences between using sites and warehouses in CloudSuite Business.	Decide whether your company really requires a multi-site setup. If not, skip the rest of this document.
3	If multi-site, should you use separate site databases or combine them in a single database?	Decide how to set up sites in application databases.
4	Do you need separate entities? If yes, then how many different entities do you need?	<ol style="list-style-type: none">1 Update your flowchart with any changes to the site/entity reporting structure.2 Update your flowchart with any changes to the site/entity reporting structure.
5	How many sites do you need? Determine the optimal number of sites for your system. Then determine some basic information about each site.	<ol style="list-style-type: none">1 Update your flowchart with any changes to the site reporting structure.2 If your system will have sites/entities with different base (domestic) currencies, make a list of the 3-character currency codes to be used for those base currencies.3 Update your <code>SiteEntity</code> spreadsheet with any changes to the list of sites. For

Step	Question	Tasks
		<p>each site, specify the time zone, SQL server name or local node name, computer and domain name.</p> <p>Also specify the base currency for each site.</p>
6	<p>Can you use the same Forms database for multiple sites?</p> <p>Do you need multiple Forms databases, and if so, which application databases should each one be linked to?</p>	<p>Update your <code>SiteEntity</code> spreadsheet to specify the Forms database used with each site.</p>
7	<p>Can you use the same Objects database for multiple sites?</p> <p>Do you need multiple Objects databases, and if so, which application databases should each one be linked to?</p>	<p>Update your <code>SiteEntity</code> spreadsheet to specify the Objects database used with each site.</p>
8	<p>How should sites be grouped?</p> <p>Do you need multiple groups for different multi-site functions or users?</p>	<ol style="list-style-type: none"> 1 Create a list of potential Site Groups. 2 Update the <code>SiteEntity</code> spreadsheet to specify which Site Group the site should reside in initially.
9	<p>What configurations do you need?</p> <p>Do you need different sets of configurations to be available to different sets of users?</p> <p>Will you need multiple utility servers and thus a designated configuration server?</p>	<ol style="list-style-type: none"> 1 In the <code>SiteEntity</code> spreadsheet, add the configuration name and application database name for each site - or else create a <code>Configuration</code> spreadsheet. 2 Determine what configuration groups you need. 3 Decide which web/utility server is the Configuration Server.
10	<p>How many CloudSuite Business intranets do you need?</p> <p>Review your physical requirements: web servers, utility servers, etc.</p> <p>Decide on the intranet names, and which sites will belong to each intranet.</p>	<p>Update the <code>SiteEntity</code> spreadsheet to indicate the name of the CloudSuite Business intranet to which each site is connected.</p>
11	<p>How do you want to use web rendering?</p>	<p>Decide which utility server you want to use for the Web client, and determine the URL to access the Web client.</p>
12	<p>Which data needs to be shared between sites?</p> <p>What categories of data need to be replicated?</p>	<ol style="list-style-type: none"> 1 Update the flowchart with arrows indicating the categories of data being shared, and the directions the data is flowing.

Step	Question	Tasks
	<p>Which sites need to share that type of data? Does data need to be shared in both directions?</p>	<p>2 Create a <code>ReplicationRules</code> spreadsheet listing each of the categories you think you will need, in each direction, from each site.</p>
13	<p>Should some data be shared through a master site and SQL views rather than through replication? You might decide to set up master sites and shared views for some areas of your system.</p>	<p>1 Update the flowchart with boxes indicating master sites, if used. For data flowing to a master site from using sites, use a different type of arrow.</p> <p>2 Update the <code>SiteEntity</code> spreadsheet to indicate any sites that are master sites.</p> <p>3 Create a list of the tables that are controlled by the master site.</p> <p>4 If some of the rules you thought you would need have been replaced by the use of a master site, remove the rules from the <code>ReplicationRules</code> spreadsheet.</p>
14	<p>If you will replicate data, how often? Should you use transactional or non-transactional replication?</p>	<p>Update the <code>ReplicationRules</code> spreadsheet to indicate which rules are transactional or non-transactional. If using non-transactional rules, specify the interval type and timing.</p>
15	<p>Will you be using the event system?</p>	<p>Consider how event data might be replicated. Create an <code>Events</code> spreadsheet listing the configurations to monitor.</p>
16	<p>What modules or products will interface with each site? Will you be interfacing CloudSuite Business to an external financial interface, EDI, an Infor BOD-enabled application, etc.?</p>	<p>Update the flowchart and spreadsheets as needed, if you decide to rearrange your sites due to add-on product requirements.</p> <p>If a site interfaces with an application via Infor BODs, update the <code>SiteEntity</code> spreadsheet with the logical ID.</p>
17	<p>How many licenses (and what types) do you need? Determine which users - and how many users - will need to work in multiple sites.</p>	<p>Create a <code>License</code> spreadsheet listing the sites and the license modules and number of licenses required for each site.</p> <p>If some sites use intranet licensing, note their intranet's master site in the spreadsheet.</p>
18	<p>Is your naming scheme logical? Name sites, configurations, intranets, and site groups to indicate the logical structures and relationships.</p>	<p>Update the flowchart and spreadsheets with any name changes.</p>

Step	Question	Tasks
19	How easily will your structure incorporate later changes? Think about how radical changes to your company hierarchy may affect the structure.	Revise your flowchart and spreadsheets if you decide to rearrange your hierarchical structure.

Note: Planning and implementing a multi-site system is not a simple task. We recommend that you discuss the process and the results of your planning decisions with Infor Consulting Services prior to implementation.

Contacting Infor

If you have questions about Infor products, go to the Infor Xtreme Support portal.

If we update this document after the product release, we will post the new version on this website. We recommend that you check this website periodically for updated documentation.

If you have comments about Infor documentation, contact documentation@infor.com.

Determining your corporate structure

1

What hierarchical structure does your company require for these functions:

- Financial reporting
- Sharing of administrative data
- Sharing of customer orders and invoices
- Transfer of materials

Creating a flowchart that shows your hierarchy

Draw a flowchart showing your company's site hierarchy. Use a pencil, or use an application that lets you draw flowcharts on your computer, because you will probably change the flowchart several times. You will use the information in later chapters of this guide to help you refine your flowchart.

Example

This multi-site corporation has facilities in three locations. The flowchart shows the logical structure of the company, set up as sites and entities.

Illinois Facility: This is the corporate office and the United States divisional office. It has a warehouse for shipping and receiving. Orders shipped from this site are invoiced from this site. This facility also processes all sales orders, receivables and payables for the other two sites.

California Facility: The California facility has a warehouse for shipping and receiving. Orders shipped from this site are invoiced from this site. One product line is sourced at this location from a Mexican vendor.

Ontario Facility: The Ontario facility is the Canada divisional office and has a warehouse for shipping and receiving. Orders shipped from this site are invoiced from this site. A product line from this location is sourced from a Canadian vendor.

The arrows show how different categories of data would flow between the sites and entities at this example company. Do not be concerned with the arrows yet, although you may want to include some possible data flows.

Categories will be explained later. See "Sharing data between sites" on page 77.

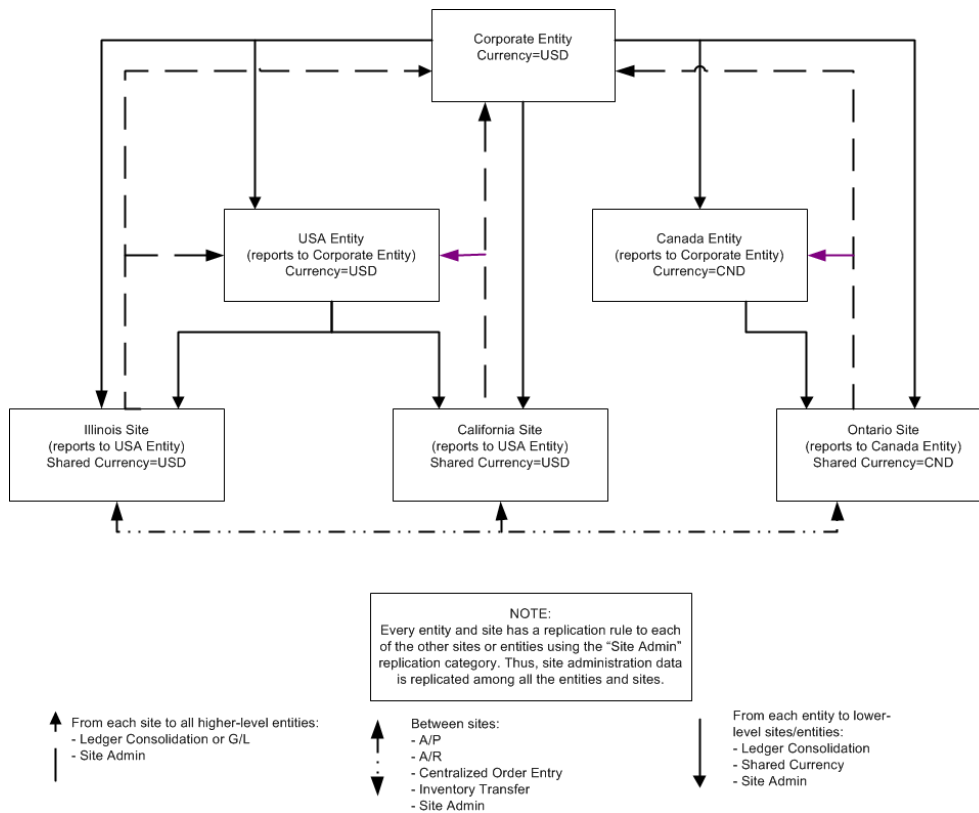

Creating a SiteEntity spreadsheet

Create a spreadsheet named SiteEntity that lists this information for each potential site:

- **Site ID:** Up to 8 characters. Avoid using these special characters in site names or IDs: \ (back slash) / (forward slash) : (colon) * (asterisk) ? (question mark) " (double quote) < (left arrow) > (right arrow) | (vertical bar) (embedded space)
- **Site Name:** Up to 60 characters, including spaces. This is the long name for the site. It appears along with the Site ID on several forms. (In some forms, this field is truncated.) For example, if your Site ID is ONT, your Site Name could be Ontario.

You might want to include the type (site or entity) information in the name; for example, "Ontario Site."

- **Site Description:** Up to 40 characters, including spaces. This text could describe both the location of the site and what it is used for. For example, "Illinois Site - Distribution."
- **Site Type:** Specify Site or Entity. See the background information section for more information about how to determine this.
- **Application Database Name:** Use standard SQL database naming conventions. Application database names might include the site ID (for an environment with one site per database) or some

other identifying characteristic. Generally you should end the name with the type of database; for example ONT_App.

The information in the spreadsheet columns should match your sample flowchart.

	A	B	C	D	E
1	SiteID	SiteName	SiteDescription	SiteType	AppDBName
2	CRP	Corporate	Corporate Entity	Entity	Crp_App
3	USA	United States	United States Entity	Entity	USA_App
4	CAN	Canada	Canada Entity	Entity	Can_App
5	ILL	Illinois	Illinois Site	Site	Ill_App
6	ONT	Ontario	Ontario Site	Site	Ont_App
7	CAL	California	California Site	Site	Cal_App

You will add more columns for each site in later chapters. This information is used when you create and configure sites.

Background information

You can perform these multi-site functions in CloudSuite Business:

- Move or transfer material or items between sites or warehouses.
- Combine data from sites at financial entities.
- Ship to common customers and receive from common vendors.
- Share administrative functions between sites.
- Centralize payment processing (between sites having the same currency).
- Centralize customer order entry.
- Centralize maintenance of customer, item and vendor data at a master site for an intranet.
- View Accounts Payable and/or Accounts Receivable transactions across sites.
- View item availability across sites.
- View "Home" form information across sites.
- Copy an item's bill of materials (BOM) between sites.
- Maintain and validate licensing across sites on an intranet.
- Use "builder" forms to enter manual journal entries, vouchers, purchase orders, invoices and credit memos for multiple sites at a central location.

Determine which site and warehouse is best for shipping orders, based on distance, quantity available, and planned production time.

Logically, a site is any place where work is done.

Thus, a site can correspond to company headquarters, a manufacturing plant, a distribution center, or a legal company that requires financial reporting. Even if all of these facilities share a single physical building, each may be considered a logical site.

Sites can report to financial reporting units called entities. An entity is a separate instance that maintains accounting periods, chart of accounts, and currency, and reports on its consolidated ledger and budgets. Sites can report to only one entity, and they must share characteristics with the entity such as account numbers and base (domestic) currency.

For more information about setting up and using entities, and making sites report to them, see the background information in "Entities" on page 41.

Sites and entities are defined during CloudSuite Business database server installation. Additional information about each site and entity is set up on the Sites/Entities form.

This information includes the intranet used by the site and any linked sites. You can set up replication rules to transfer data between sites, or you can specify master sites that maintain data for multiple sites.

For information on these features, see "Sharing data between sites" on page 77 and "Sharing some data through master sites" on page 97.

You can also set up site groups to combine data for sites performing related functions, for example, AR payment generation or subcomponent manufacturing. Sites in a group do not have to report to the same entity, but they do need to share the appropriate data through replication. See "Grouping sites" on page 59.

You can add or remove sites later, as required by your situation.

You can also create new entities, add a new site to an existing entity, and/or move sites from one entity to another.

Company hierarchies

A corporate entity can have child entities, for consolidating reporting at different levels, and each entity can have child sites. Each site can contain multiple warehouses, and each warehouse can contain multiple item stockroom locations to store inventory.

This chart shows the hierarchical relationship between components of a company:

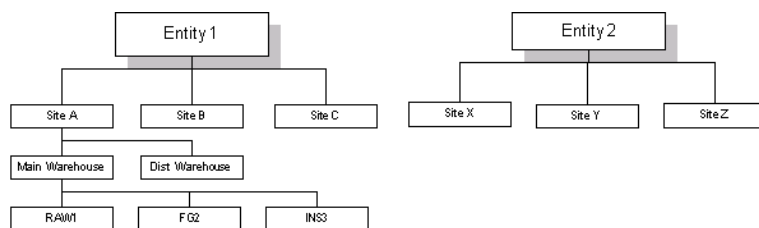

Sites A, B, and C are grouped to form Entity 1. There are two warehouses under Site A: Main and Dist. There are three locations shown under the Main warehouse: RAW1, FG2, and INS3. Entity 2 has three sites (X, Y, and Z) reporting to it.

Does your system require multiple sites, or is a single-site, multi-warehouse system better for your company?

You must understand the differences between a multi-site environment and a multi-warehouse environment, so you can decide which one your company should use.

Multi-site considerations

A multi-site system includes multiple sites, site-specific controls, and the ability to transfer demands and materials between sites through centralized order entry and transfers. Multi-site functionality was designed for businesses that have relatively autonomous sites. If most of your company activity is centralized, such as planning, purchasing, and accounting, then multi-site might not be the best option.

These are reasons to use multiple sites:

- The same items can be made at different plants using different manufacturing methods.
- Sites will have separate control of jobs, POs, COs, and inventories. (Within one site, special prefix numbering can be used to keep the data organized.)
- Inventory levels can be monitored across sites.
- A site might need to run autonomously due to technical infrastructure or communications reliability.
- Goods can be transferred between sites, with or without recognizing sales and profits.
- Sites can use different charts of accounts or different base currencies.
- Centralized order entry is available to link customer demands between sites.

In addition, it is easier to break out financial information for different sites, rather than for different areas within one site.

Multi-warehouse

Multi-warehouse allows the setup of multiple warehouses within one site. Revenue and expense information for goods and services is controlled through the use of Product Code distribution accounts. All other company information, such as chart of accounts, invoices, vouchers, and scheduling, is shared between the warehouses.

These are reasons for using one site with multiple warehouses:

- Centralized MRP and planning.
- A manufacturing process, within a routing, moves between manufacturing locations.
- Centralized purchasing, centralized entry of A/P vouchers, or accounting that creates many journal entries across locations, for example, allocating corporate expenses among all sites.

Note, however, that the "builder" features in CloudSuite Business allow you to handle some of these centralized requirements in a multi-site environment. See the online Help for information about the PO, voucher, invoice and journal builders.

Deciding whether you need multi-site

Use the background information to determine whether your company needs a multi-site system.

- 1 When you read the questions in the tables, write a "weight factor" from 0 (not important to your company) to 5 (very important) next to each question. Also, write down whether your answer to the question indicates the need for multi-site or single-site. If neutral, write "neutral."
- 2 When you have completed all the questions, add up your scores for multi-site vs. single-site. This score should give you some insight about which setup is best for your company.
- 3 Read the background information on warehouses to better understand how they are used in Cloud Suite Business.
- 4 If you decide that you need a multi-site system, then continue with the next chapter.
If a single-site, multi-warehouse setup will meet your needs, you are finished with the evaluation process, and you can skip the rest of this guide.

Background information

Consider your company's responses to these questions to determine whether to use multiple sites or one site with multiple warehouses. The symbols to the left of the descriptions indicate, for each question, whether the multi-site or single-site option is better, worse, or neutral:

- + Better
- - Worse
- = Neutral

Financial considerations

Financial considerations include General Ledger, Accounts Payable, and Accounts Receivable questions.

General Ledger

G/L question	+/-	Multi-site	+/-	Single site with Multi-Warehouse
Are there multiple reporting entities (Balance/P&L)?	+	Multi-Site supports Profit & Loss and Balance Sheet statements by site.	=	Single Site supports P&L statements by distribution codes. A Balance Sheet is only available for the whole site. If unique Balance Sheets are required, they must be constructed manually. Warning: this process is manual and complex.
Is consolidated financial reporting required?	+	Multi-site supports the consolidation of reporting units within a site, multiple sites at the entity level, and multiple entities at the corporate level.	=	If multiple, non-linked databases are used, export/import utilities can be used to transfer G/L information.
Do you have completely different account numbers in different areas of the company?	+	Chart of accounts are the same at sites as at the entity they report to, or the sites contain a subset of the entity's chart of accounts. If completely different account numbers are used in different areas, then separate entities must be created.	-	Only one Chart of Accounts is supported for all areas.
Are inter-company sales present?	+	Inter-company (sites) sales are recognized at the site and eliminated at the entity level through the Ledger Consolidation activity.	-	This is not supported.
Are entries required at the entity level?	+	Financial entries can only be entered at the site level. A separate legal, business entity, like a holding company, may require a separate site. Note: Entries can also be made at each site to an inter-company 'offset' account that will net zero when a consolidated financial is run.	-	Financial entries can be entered within the site. (There is no separate "entity" level.)
Is reporting performed in multiple currencies?	+	Different sites may have different base (domestic) currencies, but each site must have the same domestic currency as the entity it reports to.	-	One base reporting currency is available.

G/L question	+/-	Multi-site	+/-	Single site with Multi-Warehouse
How are financial statements maintained?	=	Financial statements should be maintained in each site or entity. Statements can be copied across sites. Sites typically run statements for their own ledgers. Entities typically run statements for the sites that report to them. However, you can run statements for any combination of sites from any site or entity, as long as the appropriate data is being replicated.	=	Financial statements exist at the site level.
Do you need to manually input journal entries for multiple sites from one location?	+	From a central site, you can use Journal Builder to enter journal entries for multiple sites.	=	There is only one site and one set of journals.

Accounts Receivable:

A/R questions	+/-	Multi-site	+/-	Single site with multi-warehouse
Is centralized order entry required?	=	Centralized and decentralized order entry strategies are supported.	=	Centralized and decentralized order entry strategies are supported.
Is consolidated invoicing performed across sites?	=	Multi-site does not support consolidated invoicing. Invoicing is controlled at the site level. However, you can use the Invoice Builder to create and post invoices and credit memos for the current site and other target sites for customer order shipments and returns	+	Consolidated invoicing is supported.
Is centralized cash application required?	=	Multi-site supports centralized or decentralized cash application. Cash application across sites using the same base currency is supported. Cash application across sites using different base currencies is not supported.	=	Centralized cash application is supported. All warehouses must maintain the same base currency.

Accounts Payable:

A/P questions	+/-	Multi-site	+/-	Single site with multi-warehouse
Is consolidated vouchering across sites required?	=	From a central site, you can run Voucher Builder to create vouchers and adjustments for other sites when generating vouchers from PO Receipts. You can also create manual vouchers across sites; however manual adjustments across sites are not supported.	=	Supported via a single site.
Are centralized payments required across sites?	=	Multi-site supports this functionality.	=	Supported via a single site.
Do the payment sites have the same currency?	=	All sites sharing payment information must have the same base currency.	=	All warehouses must maintain the same base currency.
Are centralized commissions required?	=	Multi-site supports centralized commission payment across sites.	=	Supported via a single site.
Is centralized vendor maintenance required?	=	Multi-site, with a master site setup, supports centralized adding and maintaining of most vendor data. Deletion must be done at sites.	=	Supported via a single site.

Manufacturing considerations

Manufacturing considerations include job, production schedule, and material resource planning questions.

Job and Production Schedule:

Job/PS questions	+/-	Multi-site	+/-	Single site with multi-warehouse
Do job operations extend across warehouses or sites?	=	Multi-site does not support the planning of production across sites. All operations must be only for the local site. All outside production must be treated as an outside purchase in logic with different item numbers. Multi-site supports the copy of current and single level BOMs across sites.	=	One warehouse per site is designated for production; any additional warehouses are designated for storing inventory. This is also true for multi-site with multiple warehouses per site.

Multi-site vs. multi-warehouse

Job/PS questions	+/-	Multi-site	+/-	Single site with multi-warehouse
Are capacity and manufacturing schedules viewed across warehouses or sites?	=	Multi-site does not support the scheduling of production across sites. All outside production must be treated as an outside purchase in logic with different item numbers.	=	One warehouse per site is designated for production; any additional warehouses are designated for storing inventory. This is also true for multi-site with multiple warehouses per site.
Do you make the same item at different plants using different processes?	+	If your item run-times or routings are different at different manufacturing sites, you probably need a multi-site system.	-	In a single current site, you can have only one routing and BOM for an item. (However, jobs can have different routings/BOMs for the same item.)

MRP:

MRP questions	+/-	Multi-site	+/-	Single site with multi-warehouse
Is centralized planning required?	-	Multi-site through the use of linked MRP allows demands to be pushed to other sites. There is no other method to consolidate material requirements. Planned orders can only be performed at the local level, not across sites.	+	Supported via a single site.
Do different areas have different planning and scheduling requirements?	+	Planning and scheduling are done per site.	-	Not supported.

Payroll/Human Resources considerations

Payroll/HR questions	+/-	Multi-site	+/-	Single site with multi-warehouse
Is payroll performed at a "global" level?	-	Multi-site does not support payroll processing across sites.	+	Supported via a single site.
Do employees work in more than one division?	=	Employees working in multiple sites must be set up and processed at each local site.	=	Departments must be set up to support this process.
Will sales representatives be	-	If sales representatives will be paid through payroll, all commis-	+	Supported via a single site.

Payroll/HR questions	+/-	Multi-site	+/-	Single site with multi-warehouse
paid through payroll?		tion processing will be processed at the site.		

Operations considerations

Operations considerations include order entry, purchasing, inventory control, and transfer order questions.

Order Entry:

Order entry questions	+/-	Multi-site	+/-	Single site with multi-warehouse
Is centralized order entry required across sites?	+	Centralized and decentralized order entry strategies are supported.	=	Supported via a single site.
What order and invoice number logic is used across sites?	=	CO prefixes must be used in each site to properly identify and track orders. Invoice sequences will be maintained at the site level. The "Site ID" is added as a prefix to the invoice number.	=	CO prefixes are available within a site.
Are shared customers required?	=	Multi-site, with a master site setup, supports centralized adding and maintaining of most customer data. Deletion must be done at sites.	=	One customer master is utilized within the site.
Are site-level customer credit limits required?	+	If centralized order entry is set up between sites, and the same customer number is defined in multiple sites, then that customer's credit limits, posted balance, and on order balances display the total for that customer from all the shared sites. Local (unshared) customers allow local credit limits and balances.	=	Supported via a single site.
Is invoicing required by order with central order entry?	+	Invoicing is performed by the ship site. If one line on an order is shipped from one site and another line is shipped from another site, two invoices will be generated. However, you can use the Invoice	=	Supported via a single site.

Order entry questions	+/-	Multi-site	+/-	Single site with multi-warehouse
		Builder to create and post invoices and credit memos for the current site and other target sites for customer order shipments and returns.		
How are performance measurements reported?	=	Order entry information, such as ship date vs. due date, is maintained at the site level.	=	Order entry information, such as ship date vs. due date, is maintained at the warehouse level.
Is global pricing maintenance required?	-	All pricing logic is maintained at the site level. If central order entry is used, the price that defaults to the order line comes from either the site that is taking the order or from the ship site (depending on order entry parameters). The ship site cannot update the quantity or the price on an order that originated in another site. No mass update utility exists across sites for maintenance.	+	Supported via a single site.
Are sales analysis and booking required across sites?	+	All sales analysis and booking information is maintained at the site level. However, on the Salesperson Home form you can see the information for various sites, or for all sites.	=	Supported via a single site.
Are global salespersons and commission logic used?	=	If centralized order entry is used, the central order site must contain all possible salespersons. Commission information cannot be input at the central order entry level. Commission distributions must be set up and maintained at the site level.	=	Supported via a single site.

Purchasing:

Purchasing questions	+/-	Multi-site	+/-	Single site with multi-warehouse
Is consolidated requirements planning required?	-	Multi-site has no ability to provide requirements planning across sites. All requirements are planned at the site level.	+	Supported via a single site.
Is centralized purchasing per-	=	Builder purchase orders can be entered at one site to create pur-	=	Supported via a single site.

Purchasing questions	+/-	Multi-site	+/-	Single site with multi-warehouse
formed across sites?		chase orders for other sites. Maintenance of these POs is then done at the individual sites.		
Is centralized receiving performed across sites?	-	Multi-site has no ability to provide centralized receiving across sites. All receiving is performed at the site level.	+	Supported via a single site.
Are shared vendors required?	=	Multi-site, with a master site setup, supports centralized adding and maintaining of most vendor data. Deletion must be done at sites.	=	One vendor master is utilized within the site.

Inventory:

Inventory questions	+/-	Multi-site	+/-	Single site with multi-warehouse
Is standardized item number logic used across sites?	=	Multi-site, with a master site setup, supports centralized adding and maintaining of most item data. Deletion must be done at sites.	=	Supported via a single site.
How is materials planning performed?	=	Item availability across sites is only available using Item Availability (with drilldown). No reports combine on-hand balances across sites.	=	Supported via a single site.
Is item cost different at different warehouses?	=	You can set item costing at either the warehouse or site level.	=	You can set item costing at either the warehouse or site level.

Transfers:

Transfer questions	+/-	Multi-site	+/-	Single site with multi-warehouse
What transfer controls, visibility, and documents are required?	=	The proper transfer process will be related to the controls, visibility, and documents that the customer requires.	=	Same logic.
Is profit recognized from inter-site material transfers?	+	Multi-site allows you to recognize and eliminate inter-site transfer profits. The transfer pricing logic is linked to the price matrix and transfer pricing. The elimination of	-	Warehouse transfers are supported. Inter-company sales are not supported.

Transfer questions	+/-	Multi-site	+/-	Single site with multi-warehouse
		inter-company profits is linked to the Ledger Consolidation activity.		

Administration/technical requirements considerations

Admin questions	+/-	Multi-site	+/-	Single site with multi-warehouse
Where is system administration performed?	=	Users can be global or local. Authorizations for global users can be set locally at each site, or globally.	=	Supported via a single site.
How will sites be connected (LAN/WAN)?	=	Determines the type of replication you can use and how sites are connected.	=	N/A
Where will system administration personnel be located?	=	Remote administration of sites may present challenges	=	Assumes system administrator is in same physical location as database.

Warehouses overview

Each site has at least one warehouse, designated as MAIN, which is created during system installation. In most cases, this also becomes the default, or primary, warehouse for the site, but you can change the default.

Multiple warehouses

Many companies have more than one location in which to store inventory, so you can add warehouse locations to the list of warehouses available for various transactions. To add warehouses, use the Warehouses form. You can also use this form to view and update information for all warehouses in the system.

Item stockroom locations

Before you can show inventory in your warehouses, you must establish item stockroom locations. Each warehouse can contain multiple item stockroom locations where you store inventory for lot-tracking and other audit-trail purposes. Add these item stockroom locations using the Locations form.

Item/warehouse records

When you add an item to the system using the Items form, an item/warehouse association (or record) for the item is created automatically. For this record, the default warehouse is used as defined in the **Default Whse** field on the Inventory Parameters form. An item stockroom location is also automatically created for the item, using both the default warehouse and the default location defined on the Inventory Parameters form.

If you want to stock an item at multiple warehouses, you must create an item/warehouse association for each warehouse location. To create these item/warehouse associations, use the Item/Warehouse form. You can then use the Item Stockroom Locations form to add quantities of the item to locations within the designated warehouse.

Consignment warehouses

There are two ways to use a consignment warehouse:

- You can specify some of your warehouses as vendor consignment warehouses, where vendor materials are stored until you decide to consume or purchase them.
- You can specify a customer's warehouse as a customer consignment warehouse, where you store some of your materials until the customer decides to consume or purchase them.

For more information regarding the setup of customer and vendor consignment warehouses, see the online help topic about consignment warehouse setup.

Warehouse default values

Many of the forms where you can select a warehouse use a default warehouse setting. In all cases, you can override this default setting by selecting a different warehouse.

The values for the default warehouse settings on different CloudSuite Business forms come from various places. The About Warehouses help topic explains where the various default warehouse values are set up.

About the current warehouse

Many forms take as their default value the warehouse that the system recognizes as the "current warehouse," which can change on a per-user, per-session basis. When the system designates the current warehouse," it uses these rules:

- When you log in, the system designates the warehouse from the your profile as the current warehouse for that session. This setting is defined in the Whse field on the Users form.
- If that field is blank, the system uses the Default Whse field on the Inventory Parameters form.
- At any point after logging in, you can change the current warehouse setting in the Change Warehouse form.

Note: This current warehouse setting is valid only on a user-session basis. That is, the current warehouse setting can be different for each user logged in to the system. This setting is only in effect as long as you are logged in. After you log out, the setting reverts to your default user setting, if any.

Setting warehouse defaults manually

There are several ways to manually change warehouse default settings:

- Change the system default warehouse using the **Default Whse** field on the Inventory Parameters form.
- Change a user's default current warehouse setting using the **Whse** field on the Users form. See the About the Current Warehouse help topic.
- As a user, change the current warehouse setting for your current session using the Change Warehouse form. See the About the Current Warehouse help topic.
- Change the default warehouse for a range of customers using the Set Default Warehouse form.
- Change the default warehouse for a range of vendors using the Set Default Warehouse form.
- Change the default warehouse for a range of users using the Set Default Warehouse form.

Containers

Inventory movements can be expedited through the supply chain by replacing single inventory transactions with bulk (container) inventory transactions. Inventory in CloudSuite Business can be grouped into containers that are assigned to a stock location for a warehouse. Each container is assigned a unique container number, and incoming inventory can be added into the container. You can specify a container number during an inventory transaction, and the system performs all the single-level inventory transactions transparently.

How MRP, APS, and MPS Processor use warehouses

The MRP, APS, and MPS Processor planning functions view on-hand inventory as the total on-hand quantity (that is, On Hand - Qty Reserved for customer orders) at all nettable stockroom locations across all warehouses at the site.

For example, suppose you have a customer order for 150 of an item. The item is stored at three warehouses: A, B, and C. Warehouse A contains 50 on-hand, warehouse B contains 50 on-hand, and warehouse C contains 50 on-hand. When you run MRP or APS Planning or the MPS Processor, the system allocates on-hand from all 3 warehouses to satisfy the demand, and no planned orders are needed. This planning behavior occurs regardless of any specific warehouse specified on the customer order.

Dedicated remote warehouses

In some situations, you may want a warehouse to serve only local-area orders and not orders entered at the main facility. In the above example, suppose you wanted to "protect" the inventory at warehouse C so it could be used only for specific customer orders. To do this, select the Dedicated Inventory field on the Warehouses form for that warehouse.

When you run MRP or APS Planning or MPS Processor, the system ignores the inventory in the dedicated-inventory warehouse. Likewise, these planning functions ignore all demands and supplies that specify a dedicated-inventory warehouse.

Be aware of these restrictions on dedicated inventory:

- You cannot select the **Dedicated Inventory** option for a warehouse selected as the default warehouse on the Inventory Parameters form.
- You cannot perform the Get ATP or Get CTP function on a line item (for example, on the Customer Order Lines form) that is associated with a dedicated-inventory warehouse.
- The Planning Detail and Planning Summary forms do not display any inventory transactions related to dedicated-inventory warehouses.
- The exception message "Initial On-Hand Quantity Negative" (which appears on the Planning Detail form and on the Exceptions Report) does not consider inventory at dedicated-inventory warehouses.
- The planning functions ignore demands set to ship from dedicated-inventory warehouses and supplies set to supply dedicated-inventory warehouses.

Dedicated inventory and planning of transfer orders

Outgoing transfer orders are not planned as demands at the current, local site if the warehouse specified as the From warehouse is a dedicated-inventory warehouse. However, that transfer order is planned as a supply if it is sent to a warehouse at the same site that is a non-dedicated inventory warehouse (that is, if the To warehouse is one in which the **Dedicated Inventory** field is not selected).

Incoming transfer orders are not planned as supplies at the current, local site if the To warehouse is a dedicated-inventory warehouse. However, that transfer order is planned as a demand if it is received from a warehouse at the same site that is a non-dedicated inventory warehouse (that is, if the From warehouse is one in which the **Dedicated Inventory** field is not selected).

Distribution warehouses

Distribution warehouses are dedicated-inventory warehouses that are designated to plan intra-site transfers using the transit time, in days, between the default warehouse and a distribution warehouse. For these transfers, the original demand is ignored, but the pre-planning process generates planned transfer orders based upon the demand at the distribution warehouse. New planned intra-site transfers represent demand for the planning engines.

Sourcing percentages of planned orders

You can set rules that automatically split planned transfer orders for a certain item or product code between multiple sites and warehouses, specifying what percentage of the order comes from which site/warehouse. For more information, see the online help about creating source rules for planned orders.

Determining the best site and warehouse to fulfill an order

When you fulfill customer orders, use the Multi-Site Item Sourcing form to determine the driving distance between each site/warehouse and the Ship To address, using the Google Distance API. You can use the distance, along with the quantity available at the warehouse and the planned production time, to select the best source site and warehouse for an order.

Moving inventory between locations

Use transfer orders or multi-site quantity moves to move inventory from one warehouse to another (within the same site or across sites). See "Material transfers between sites" on page 47 for more information.

A hypothetical shipping and receiving scenario, in which both warehouses are within the same site, is shown below:

- Warehouse A transfers to Warehouse B.
- Warehouse A ships to a Transit Location, which is maintained at Warehouse B.
- When Warehouse B receives the item, it is moved from the Transit Location to a Stock Location within Warehouse B.

This diagram shows the process.

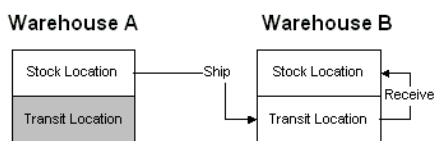

Moving quantities between locations

Use these options to move inventory:

- Use the Multi-Site Quantity Move utility to move inventory between different sites, warehouses within the same site, or locations within a single warehouse, you can.
- Use the Warehouse to Warehouse Bulk Transfer utility to move inventory between two warehouses within the same site.
- Use the Quantity Move utility to move inventory between different locations within a single warehouse.

Transferring lot- and serial-tracked items

When you transfer a lot-tracked or serial-tracked item from a warehouse at one site to a warehouse at another site, there are issues to consider regarding whether the lot or serial number exists at each site and in what location it will be created. These issues are described in the online help.

Counting warehouse inventory

Counting inventory is done at the warehouse level. There are two primary ways to count the existing inventory at each warehouse:

- Performing a cycle count: Count your inventory quantities at each warehouse and stock location on a scheduled, cyclical basis. You can define cycle-count triggering options at each warehouse to instruct the system to create a cycle count record each time a particular inventory event occurs at that warehouse.

- Performing a physical inventory: Perform a physical count of the inventory in a warehouse. This process prints tags and/or sheets for personnel to use when they count the inventory in stock and then manually enter that information into the physical inventory system.

Multi-site per database vs. one site per database

3

This chapter explains the differences between an environment with multiple sites all in one SQL database, versus an environment with each site in a different SQL database.

You can also set up an environment where you have multiple sites in one database, and another site in a separate database.

This table shows the advantages and disadvantages of each type of environment:

Topic	Multiple sites per database	One site per database
Maintenance	<p>Pro: Because you have only one database, backups, administration of indexes, etc. are easier.</p> <p>Con: Backups and restores take longer to complete for all sites participating, and will take progressively longer over time, exponential to the number of sites. Increased time to run index rebuilds, analysis, statistics, etc.</p> <p>Con: Only one recovery model can be selected.</p>	<p>Pro: Backups and restores can be done on the databases (sites) during the various sites' maintenance windows, based on each site's operations low utilization or down times.</p> <p>Con: Administration of multiple databases for indexes, statistics and database maintenance is more complex and potentially more time-consuming.</p> <p>Con: Data recovery, high availability, and disaster recovery could require coordination between multiple database (site) failover points for all of the application databases.</p>
Upgrades and issue fixes	<p>Pro: Because you have only one database, upgrades are easier.</p> <p>Pro: You have one copy of the stored procedures and functions that is used by all of the sites in</p>	<p>Pro: Single sites can be upgraded to new versions of CloudSuite Business, rather than having to simultaneously train and convert all sites at once. (However, this gets more complicated if the site is replicating data to other sites.)</p>

Topic	Multiple sites per database	One site per database
	<p>the database. So when you upgrade or install bug fixes, you only have to update one database.</p> <p>Con: When you apply single fixes that involve core database logic (method calls) such as stored procedures, etc., the fix impacts all sites.</p>	<p>Con: You have multiple copies of the stored procedures and functions in each site SQL database that is used by the specific site. So when you upgrade or install issue fixes, you must update all site databases.</p>
Processing speed	<p>Pro: If all your sites are in one database, tasks that require performance of queries, stored procedures or functions at another site may display results more quickly at the originating site, because they can take advantage of shared memory.</p> <p>Con: Writes to the log file of a single instance database with multiple sites could create a bottleneck at the log file. Log file maintenance is more important in this scenario.</p>	<p>Pro: Each site can be separately administered and tuned to best perform for the usage of that site (memory allocation, backup schemes, number of active sessions, etc.)</p> <p>Con: Collecting and querying data from multiple databases is less efficient. You need multiple execution plans and connection sets.</p>
Data integrity	<p>Pro: Keeping data in sync between sites is easier, especially after a restore</p>	<p>Con: You could lose some multi-site data integrity when you backup and restore individual databases in various states that are participating in a multi-site environment.</p>
System down	<p>Con: If the database goes offline, all sites are down. If you have to do a system restore or backup, it affects all sites in the database.</p>	<p>Pro: When you take a site database offline, there is little or no impact on other site databases.</p>
Scalability	<p>Con: The database server that is processing data for the single database with multiple sites will need to scale up as the database grows in size and usage. The ability to distribute site load across multiple database server infrastructure/instances would not be effective.</p>	<p>Pro: If sites reside in their own databases, you can distribute of those databases across multiple database server infrastructure/instances.</p>
Objects database	<p>Con: Only one objects database can be used with all sites in the application database</p>	<p>Pro: Sites can use different objects databases.</p>

Topic	Multiple sites per database	One site per database
Licensing	Con: A shared license is required.	Pro: You can license each site separately, or use a shared license.
Portability	Con: Use the “Add new site to an Existing Database” option to copy the site to a new database, but no option to remove one site from an existing multi-site database.	Pro: Sites are physically separate in their own database, so portability is less of an issue. A site and its contents can be moved or removed if necessary.
SQL requirements	Con: The Enterprise version of SQL Server is required.	Pro: Either the Standard or Enterprise version can be used, except when other factors such as required memory, etc. indicate that the Enterprise Edition is needed.
Other considerations	<p>Pro: UETs and events are shared between sites. (This can also be a “con.”)</p> <p>Con: You cannot isolate site-specific procedure changes, either programmatically or from a SQL security perspective. A change made to a stored procedure is visible to all sites in the same application database. Coding to exclude sites could be implemented in custom stored procedures.</p> <p>Con: If you turn on performance tuning or troubleshooting (for example, Profiler, execution plan estimation, etc.), it impacts all sites.</p> <p>For tables that contain large binary fields, rebuilding an index locks the table for all sites.</p>	<p>Pro: Sites are logically separate, each with a complete set of data and programs.</p> <p>Pro: Performance tuning and troubleshooting have less impact on the other sites running on the infrastructure.</p>

Deciding whether you need multiple sites in one database

Use the background information to determine whether your company needs a multi-site system.

Background information

These details can help you make your decision.

Switching from one option to the other

You can use the Configuration Wizard to copy a site from one database into another, which lets you merge sites into a single database or split sites into individual databases.

The copied site remains in the source database. If any other remaining sites are still valid in the source database, they must be moved to a new database, because there is currently no way to remove a site from a database.

Differences between single database vs. multiple databases

You must understand the differences between the options.

_All tables vs. base tables

If sites are in different databases, the `_all` tables in each site database contain data specific to other sites on the current site's intranet. The base (`_mst`) tables in each site database contain only data specific to the current site. The `_all` views point to the base tables.

If all sites are in one database, the `_all` tables still exist but do not contain any data. They are simply views pointing to the base tables. The base tables contain data for all sites in the database, including the current site, filtered by the `site_ref` column value. However, if at least one site listed in the `sites` table for an application database is in a separate application database, then the `_all` tables are populated, and the `_all` views point to the `_all` tables.

Event handlers

Application Event System events and event handlers (including the Active option) are defined for a database, not for an individual site. However, you can use the **Applies to Sites** field to specify the sites for which an event handler is active.

For more information about event handlers, see the *Guide to the Application Event System*.

Optional modules

Country-specific localizations, industry packs, and some optional products are installed and licensed for an application database; however, you might not want all of the sites in a database to access all of the licensed modules. For these products that are installed with CloudSuite Business, you can use the Optional Modules form at a site to enable module features for that site. See the *Infor CloudSuite Business Licensing Administration Guide* for more information about what it means to enable a module for a site.

Speed of replication

Replication between sites is faster if the sites are on the same SQL server. However, replication between sites within the same database is not any faster than for sites in different databases on the same server.

Multi-site tables and shared tables

Multi-site tables include a `site_ref` column that indicates the site to which a row of data belongs. Most application tables are multi-site and have an `_mst` suffix. Several Mongoose tables are also multi-site.

Most Mongoose tables, and a few application tables, are considered to be “shared” by all sites in a database.

For more information, see the white paper, *Coding and Schema Changes Made in SyteLine 9.00 for Multiple Sites per Database*.

Data visibility

If you have two sites in the same database that are not replicating data between each other, and are not sharing `_all` table data, a SQL user with direct database access to one of the sites can still view base (`_mst`) table data for both sites. If that is not desirable, then the two sites should not be placed in the same database.

Process defaults

Settings on the Process Defaults form apply to all sites in a database.

Modified reports

SSRS reports use Background Task Definition executable file names that are the same across a database. In a multi-site, single database system, if you need to modify report tasks so that they produce different outputs for different sites, you can set up SSRS subfolders that match the sites' configuration names. The system looks first in the SSRS subfolder that matches the configuration name for a report to run.

If the report is not found in that folder, the `SyteLineReports` folder is used.

For form-based reports or Dataview reports, you can use the scope level to distinguish between sites.

Consider these key points about entities, and read the background information about entities and consolidation. This information can help you decide whether your system requires separate entities and, if so, how many entities are needed.

- An entity exists for the specific purpose of financial consolidation, reporting, and currency translation. If your company does not require any of those features, then you do not need to define any entities.
- The chart of accounts must be the same at the sites as at the entity they report to, or the sites must contain a subset of the entity's chart of accounts.
- Financial entries can only be entered at the site level. A separate legal, business entity, for example, a holding company, may require a separate site that reports to it.
- Financial statements can be run in either an entity or a site.
- Each site must have the same base (domestic) currency as the entity it reports to. If you have areas of the company using different base currencies, and those areas must provide financial information to a reporting hierarchy, then you must have at least one entity for each currency. An entity reporting to another entity does not need to use the same base currency; the currency will be translated during financial consolidation to the next entity level.
- A site can report to only one entity. A site is not required to report to an entity, in which case its financials are not consolidated.
- Does your company frequently acquire other companies or sell off divisions? If so, it is better to "loosely couple" different divisions/companies, and keep the financial reporting separate (that is, different entities).
- It is not necessary to have a balanced financial hierarchy.
- The more levels of entities you have, the more complex the administration. Simpler is better, when possible.
- Depending on your needs, you may be able to use multi-site groups instead of creating an entity. See "Combined vs. consolidated reporting" on page 44 and "Grouping sites" on page 59.
- An entity can be stored in a separate database, or in the same database as other sites and entities.

Updating the flowchart

Update the flowchart with any changes to the reporting structure.

Updating the SiteEntity spreadsheet

If you have added or removed entities or sites, change the list in the spreadsheet.

Background information

Use this information to better understand the concepts.

Entities overview

In a multi-site environment, you can specify a hierarchy of financial entities that operating sites report to. A financial entity is a level of business operation with these components:

- A complete set of financial statements
- Its own domestic currency code, which must be shared by sites that report to it, and its own currency rates, which may or may not be shared by reporting sites/entities
- Its own chart of accounts and accounting periods, which must be shared by reporting sites. (Reporting entities do not have to share these characteristics with a higher-level entity.)

Each entity allows no business activity aside from period, chart and currency maintenance, and the reporting of its consolidated ledger and budgets.

If ledger detail is replicated to the entity from the sites, you may be able to "drill down" to view detail down to the level of the originating transaction. (This assumes that any other categories required for the transaction-level detail are also being replicated. However, having this level of G/L and other transaction detail replicated to the entity often does not make sense from a performance standpoint.) Otherwise, you must log into the specific site in order to view the transaction detail.

Sites that report to an entity

The majority of operations at sites reporting to an entity remain the same as at a non-reporting site, including the financials. However, if a site reports to an entity, the site's Chart of Accounts is now owned by the entity and is copied from it. In the site's local copy of the Chart of Accounts, you can delete records in order to use a subset of the entity's accounts.

The site must use the domestic currency of its entity, but it may use its own rates.

Journal entries must be made at the site level in order to properly recognize expenses, etc. No transactions are allowed at the entity level. All distribution journals must be posted at the sites.

Consolidation utilities must be run at the reporting sites to copy the posted ledger transactions and budgets into the entities all the way up the hierarchy.

A site is not required to report to an entity, in which case its financials are not consolidated.

Setup of entities and the reporting structure

When you create CloudSuite Business databases, or add sites/entities to an existing application database through the Configuration Wizard, you must specify a site type. For an entity, specify a site type of Entity.

Entering operational data such as customers and vendors is not necessary for entities. Maintenance and reporting of financial data is allowed.

Defining the hierarchy

To define or change the hierarchy of your sites and entities, several utilities are available in CloudSuite Business:

- **Change Reports to Entity:** Use this utility at the reporting site/entity to specify the next-level entity to which this site/entity reports. This utility can also be run if a site is sold and needs to be removed from the financial consolidation structure.
 - If this utility is run at a site, you can only change the **Reports To Entity** to a financial entity that has the same base (domestic) currency, Chart of Accounts and accounting periods. Also, the system verifies that all accounts defined at the site already exist at the financial entity. If this validation fails, the change is not allowed, and a report is created detailing the failures. If chart records exist at the site that do not exist at the entity, you can use the Multi-Site Chart Copy Utility to copy the site's Chart of Accounts to the financial entity. If no Chart of Accounts or accounting periods have been set up yet at the site, this Change Reports To Entity utility will copy them from the entity to the site.
 - If this utility is being run at a financial entity at any level, the closing balances for each account at every site beneath the financial entity are calculated and consolidated all the way up the hierarchy. Then the Reports-To value is changed. All the Reports To account mappings for the entity's Chart of Accounts must be corrected to map to the Chart of Accounts of the new Reports-To financial entity.
- **Multi-Site Chart Copy:** Use this utility at the entity to copy the Chart of Accounts down to the reporting sites and entities.
- **Ledger Consolidation:** Use this utility at the reporting site or entity to consolidate any unconsolidated ledger records (by mapping accounts and unit codes and converting currencies) up to and including the cutoff date. Each ledger record will be consolidated all the way up the hierarchy. The ledger at this site will be marked as consolidated. For higher level entities, the newly created ledgers are stored, using that entity's chart of accounts and base currency. The utility validates this information:
 - The hierarchy is valid.
 - The accounts map correctly.
 - The unit codes map correctly.
 - The currencies convert properly.
- **Budget Consolidation:** Use this utility at the reporting site or entity to consolidate all previously unconsolidated site budgets and plans through the cutoff date. All entities in the hierarchy that are

senior to the current site must be replicating G/L or Ledger Consolidation data with the current site. Each budget and plan for each account is consolidated all the way up the hierarchy; the budget and plan at the current site remains unchanged. For higher level entities, the newly created budgets and plans are stored using that entity's chart of accounts, base currency, and financial periods. If a site or entity enters and leaves a hierarchy in the course of a single year, the original budget/plan will be replaced with the later one.

- **Set Ledger Consolidated Flag:** Use this utility to rebuild an entity. Use it to reconsolidate entities whose data was lost, corrupted or discarded due to a change in corporate structure.

Multiple currencies and consolidation

When you use multiple currencies in a consolidated environment, be aware of these requirements:

- The base (domestic) currency must be the same at all sites reporting to an entity. However, you may set up the sites so they can maintain their own currency exchange rates - or you may want to maintain the rates only at the entity. See "Replicating shared currency" on page 88.
- In each entity's Chart of Accounts, the currency translation method and the exchange rate type are specified for each account. To comply with FASB52 or GAAP standards, revenue and expense accounts should use the Average translation method, and asset and liability accounts should use the End translation method.
- The currency table of the entity is the one used for translation during the consolidation. Sites use the domestic currency of their entity, so there is no currency translation at this level.

Combined vs. consolidated reporting

Financial statements can either show combined data from a group of sites, or consolidated data from an entity and its reporting sites.

If you want to create sample financial statements before changing a hierarchical structure, to see what the combined data from multiple sites will look like, you can mimic the new structure by using multi-site group IDs and combined financial statements. After creating a multi-site group that contains all the sites you want to combine, you can specify this site group when running certain General Ledger reports. To ensure meaningful reports, the sites must share the same Chart of Accounts format.

Even after you have set up a consolidated environment, you can still run combined financial statements for a group of sites.

When you run consolidated financial reports from the entity, all sites that report to the entity must have run the Ledger Consolidation utility. When the financial statement is run, no currency translation is required, because the data at the entity level is already translated into the entity's currency and Chart of Accounts. Also, since no multi-site group IDs are specified, it looks only at the information in the entity. Therefore, consolidated financial reports run much faster than combined financial reports.

Number of sites that are required

5

Determine the optimal number of sites for your system. Then determine some basic information about each site.

Simpler is better. When you have fewer sites, the less the administration is less complex.

Considerations

Base currencies

When a site or entity is created, the Site Currency is defined, also known as the "domestic" currency or the "base" currency. The currency codes to use must be decided before the sites are created.

When a site in one country executes a transaction with a customer or vendor in another (foreign) country using a currency other than the domestic currency, one currency is converted into another to settle the transaction. This conversion from one currency to another creates gains and losses depending on the currency exchange rate specified at the site. Some forms and reports show amounts in the site's domestic currency, while others display amounts in the customer/vendor's currency but can be translated to the domestic currency with the click of a button.

Customers and vendors can be set up to support transactions in currencies other than their defined "default" currency. Totals are still in the default base currency. For more information, see the online help topics about multiple currencies for customers or vendors.

All sites reporting to the same entity must use the same domestic currency as the entity.

Time zones

A time zone must be specified for each site when the site is created. The time zone for the site is independent of the time zone for the server. Multiple sites running on one server can have different time zones. The time zone for each site should be appropriate for the users of that site.

When transactions are replicated between sites, the transactions are stored in `_all` tables and use the date and time the transaction occurred at the creating site.

The only exceptions to this are dates stored in the `currdate_mst` and `curr_uk_mst` tables. Those dates will shift to show the date and time at the local site. This allows currency rates to be current for the date and time at the local site.

SQL Server name or local node name

When you create application databases on the database server, you must specify the SQL Server Name where the database will reside. If you use SQL Clustering, you specify the SQL instance of the local node in the SQL Server Name field.

Corporate financial entries and manual adjustments

If you have an entity, you must have at least one site under the entity in order to enter transactions - since no transactions may be entered at the entity.

Even if you have other sites under an entity, you might want to have a separate site used for entering corporate journal entries that do not apply to a specific site. For example, operational expenses for a private jet should be allocated equally to the ILL and CA sites, but the expenses should not appear in either the ILL or CA consolidated financials.

Manufacturing plants

How many manufacturing plants do you have? Generally each of those will require a site. Or consider whether the different plants could be handled through multi-warehouse features. See "Multi-site vs. multi-warehouse" on page 19.

Balance sheets

If different areas of the company require unique balance sheets, each area must be in a separate site.

Updating the flowchart

If you add or remove sites, or move them around in the hierarchy as a result of the information in this chapter, update your flowchart.

Creating a list of currency codes

If your system will have sites or entities with different base (domestic) currencies, make a list of the three-character currency codes to use. You might also want to define codes for other foreign currencies that will be used in the system.

Updating the SiteEntity spreadsheet

Update this spreadsheet with any changes to the list of sites and entities. For each site and entity, specify this information:

- The base currency code
- The time zone in which the site operates
- The SQL Server name - or local node name, if using SQL Clustering
- The computer and domain name on which the SQL server resides
- You can also include a column for the SQL user under which the sites will be created; however, if you always use the "sa" user, you might not need this column.

Your spreadsheet now looks like this example:

	A	B	C	D	E	F	G	H	I	J	K
1	SiteID	SiteName	SiteDescription	SiteType	AppDBName	Currency	TimeZone	SQLDBServer	Computer	Domain	SQLUser
2	CRP	Corporate	Corporate Entity	Entity	Crp_App	USD	Central Stanc	MARS	MARS	USOLAR	sa
3	USA	United States	United States Ent	Entity	USA_App	USD	Central Stanc	MARS	MARS	USOLAR	sa
4	CAN	Canada	Canada Entity	Entity	Can_App	CND	Eastern Stan	SATURN	SATURN	CASOLAR	sa
5	ILL	Illinois	Illinois Site	Site	Ill_App	USD	Central Stanc	MARS	MARS	USOLAR	sa
6	ONT	Ontario	Ontario Site	Site	Ont_App	CND	Eastern Stan	SATURN	SATURN	CASOLAR	sa

Background information

Use this information to better understand the use of multiple sites when transferring items, when using centralized order entry, or when calculating currency rates.

Material transfers between sites

There are two different ways to move or transfer items or material between sites:

- Use the Multi-Site Quantity Move form to perform simple, quick movements of inventory where there is relief of inventory in one site and receipt in another. A multi-site quantity move does not require paperwork and assumes no transit time.
- Use a transfer order for planning and controlling stock movement and availability. When a transfer order requests that the material be transferred from the shipping site to the receiving site, the shipping site must be aware of this transfer order. If the material is being transferred to the receiving site from the shipping site, the receiving site must be aware of this transfer order. Once the transfer order is entered at one site, the system creates a complementary record automatically at the other site. In addition to in-transit visibility, transfer orders support these features:
 - Landed cost
 - Full cross-referencing capability with jobs, purchase orders, and customer orders
 - The ability of the "From" site to use price codes

- Shipping paperwork and pro-forma invoices
- Multiple currencies
- Lot/serial controls

Both multi-site quantity moves and transfer orders support the use of lots and serial numbers.

In order to do moves or transfers between sites, there must be a replication rule set up for the Inventory/Transfers category between the sites. See "Sharing data between sites" on page 77.

Price codes

The price code determines the costs that are used in multi-site quantity moves or transfer orders. You can set up price codes for sites that report to different entities. If both sites are in the same entity, price codes are not used.

Accounts

Multi-site transfer accounting automates inter-company financial transactions and inter-company financial consolidation. CloudSuite Business provides parameter setup for profit/cost eliminations, and offers separate account tracking for inter-company profit, cost, accounts receivable, accounts payable, sales, and cost of sales.

Accounts must be set up to establish site relationships and default account numbers that will record inter-entity financial transactions. When initiating either a move or a transfer between sites, the costs and account numbers that default for the transaction come from the Inter-Site Parameters form and are relative to the site that initiated the transaction.

Costing

Multi-site quantity moves do not use the To and From in-transit accounts of journal entries. Instead, inventory moves directly to the buyer's inventory accounts.

Transfer orders can cause in-transit entries to occur; the act of shipping and receiving inventory moves the inventory in and out of in-transit accounts.

Transfer order costing will function in one of two ways depending on the setting of the Posting Method parameter, found on the Inter-Site Parameters form. These are the available posting methods:

- Intra-Entity: Transfers occur at cost between sites.
- Inter-Entity: transfers occur with revenue between sites, with the From Site making a profit.

Transit location

A stock location of type "transit" must exist in sites performing transfer orders. This location is used to hold the inventory between the time the shipment is made and the receipt performed.

Free On Board (FOB) site

The **Free On Board** (FOB) field on the Inter-Site Parameters form determines ownership of in-transit inventory. This is the site at which you must specify the location as "transit" for multi-site transfers.

For transfer orders, you can identify the FOB point as either the Ship Site or the Receive Site. You must specify the FOB point for all inter-company movements.

If the FOB point is the Ship Site, transfer of ownership takes place at the time of shipment. Material moves from a location in the Ship Site to a transit location in the Receive Site, and financial ownership changes from the Ship Site to the Receive Site. At receipt time, transactions are created to move the material from the transit location to a standard location at the Receive Site.

If the FOB point is the Receive Site, transfer of ownership takes place at the time of material receipt. Material moves from a location in the Ship Site to a transit location in the Ship Site. At receipt time, transactions are created to move the material from the transit location at the Ship Site to a standard location at the Receive Site. Financial ownership changes at receipt time.

FOB and costing

When a site transfers inventory to another site, inventory cost at the shipping site is relieved against the five cost categories (Material, Labor, Fixed Overhead, Variable Overhead, and Outside Services).

When a site sells inventory to a site in another entity of the company, the Inter-Entity cost of goods sold at the shipping entity is debited against the five cost categories, and inventory is relieved against all five categories.

When a site receives inventory transferred from another site, inventory is received into stock as if it were a purchased item. If the receiving site has employed standard cost, the transferred item comes into inventory using the five cost elements (Material, Labor, Fixed Overhead, Variable Overhead, or Outside Services). If the receiving site uses any other cost type, the cost comes in as Material Only.

See the online help for a list of the supported inter-site financial transaction types and examples that illustrate the different types of inter-site transactions and the resulting journal entries.

Markups

CloudSuite Business supports two types of transfer markups:

- **Profit Markup:** A site within an entity sells product to another site in a different entity at a profit. Profit is defined as any amount added by the selling entity in excess of the cost amount of the inventory shipped. This markup must be eliminated during financial consolidation. From a company-wide standpoint, entities cannot make profits by selling to each other. From Site profit must equal the To Site cost. (A markup may be established by filling in the **Price Code** on the Inter-Site Parameters form. This uses standard pricing logic.)
- **Cost Markup:** One entity or site transfers or sells a product to another entity or site and landed costs are incurred as a result of moving inventory. The seller does not increase costs to cover these expenses. It is the responsibility of the receiving entity to correctly include these costs in inventory. The CloudSuite Business Landed Cost functionality is used to include costs in the buying site's inventory. These costs are true costs to the receiving site, and should not be eliminated during financial consolidation.

Payments

Payments are entered at the From Site and distributed to the To Site.

When posting an A/P payment, the From Inter-Site Asset account is debited and the To Inter-Site Liability account is credited. When posting an A/R payment, the From Inter-Site Liability account is credited and the To Inter-Site Asset account is debited.

Multi-site linked MRP and APS

CloudSuite Business can replicate transfer orders between remote sites. When either MRP or APS creates planned transfer supply orders (PLNs) for components provided by remote supply sites, the planned transfer order is replicated to the supply site as a planned demand transfer order. See "Replicating planned transfer orders (Planning)" on page 89.

Inter-Site Parameters

The Inter-Site Parameters form must be filled out prior to any A/P, A/R, or transfer multi-site activities taking place. These parameters establish the relationship between the sites ("inter" or "intra") and identify the inter-company account numbers to be used during transactions. If your sites are set up to replicate Site Admin data, you can enter these parameters in one site and all the others will update automatically.

Centralized and decentralized order entry

If you want your sites to share customer order data, set up "centralized order entry" replication rules between the sites. This allows either of these types of order entry:

- Centralized order entry, where the company's ordering, A/R payments and/or pricing can be handled at a single site.
- Decentralized order entry, where any site can originate its own orders.

An order's shipment can span several sites: for example, lines 1-3 are shipped from Site A, and lines 4-6 are shipped from Site B. Shipping and invoicing tasks are performed at each shipping site.

When determining whether to implement centralized order entry, consider where Cost of Sales and Revenue are recognized. In centralized order entry, the shipping site incurs the cost and earns the revenue.

Be aware of these notes about multi-site customer orders:

- Credit checking and inventory visibility are provided from site to site.
- Invoice, credit, and debit memo sequences may be used to easily distinguish one site's A/R transactions from another. It is possible to create an open credit memo in one site, post it, and then reapply the credit memo to an invoice in another site. In order to prevent overlapping credit memo numbers from different sites, you should set up different credit memo sequences for different sites.
- The Item Availability form can be used to check inventory levels across sites. It uses the Site Group ID.
- Both the Shipping and Invoicing activities must take place in the "shipping" site. In a multi-site environment, invoicing is performed by each individual site. The originating site invoices only those line items shipping from its site. Other shipping sites will invoice locally for only their line items. In centralized order entry, if the originating site has no inventory, invoicing is done only by the shipping

sites, not the originating site. However, if you have Invoice Builder replication set up between sites, users can create and post invoices at one site for items that are shipping from that site and other sites, through the Multi-Site Invoice Posting form.

- A/R cash application can be done centrally, as long as the sharing sites have the same base currency. (In order to do centralized cash applications, A/R replication rules must be set up between the sites.)
- A site can make a payment for an order that originated from another site that reports to the same entity, as long as the necessary data is being replicated between the sites. However, you cannot generate a new draft payment and apply it to multiple invoices, because when an invoice is generated for a draft customer, the system creates a draft record. There is a site-specific one-to-one relationship between an invoice and a draft.
- To pull all default item prices for CO lines from the site originating the order, select **Price from Originating Site** on the Order Entry Parameters form. If this field is not selected, the system pulls the default prices from the site shipping the order line item.
- Customer order cross-referencing (to purchase orders, jobs, etc.) can only be done for the local site.
- You can use prefixes to ensure that orders are unique by site.

Using credit limits and credit hold in a multi-site environment

When you enter or change a credit limit in one site, the credit limit value is changed in all other sites replicating that data. The On Order Balance shown for the customer at each site is the cumulative balance of that customer's orders at all replicating sites. For example, a customer has a credit limit of \$100. Site 1 has one open order for the customer, for \$50. Site 2 has one open order for \$25. ("Open" in this case means Status=Ordered and nothing has shipped.) The customer's record in the Customers form shows an On Order Balance of \$75 in both sites. If you add a new CO Line Item for \$35 in either site, the proposed On Order Balance would be \$110. Even though each site fits under the credit limit, the line item is added as Status=Planned because the proposed On Order Balance has exceeded the credit limit.

In a multi-site environment, the Originating Site of a customer order controls the credit hold status of the customer order for all sites from which the customer order may be shipped.

When you initiate the Order Credit Hold Change Utility in a multi-site environment, the system performs the processing at all sites for the selected customers. The system checks the customer's credit limit against the On Order Balance to determine when the credit limit is exceeded. If a customer's credit limit is exceeded, what happens depends on the shipping site:

- If the shipping site is the originating site of the customer order, the order is placed on credit hold.
- If the shipping site is not the originating site of the customer order, a warning message displays, but the customer order is not placed on credit hold.

Payment hold for vendors

If payment hold is selected for a vendor in an environment where vendors are set up to be the same across sites, then payment hold is selected for that vendor in all sites.

Payment hold does not exist at the purchase order level.

Functions where entity data is not available

Many CloudSuite Business forms include a "Site" field that allows you to select a site or a site group. In some cases, both sites and entities are listed; however, if the data on the form is not applicable to entities, then only sites are listed.

Multiple financial sets of books

If one site is using multi-FSB, and that site is replicating G/L data to other sites, only the standard set of books for the site is replicated to the other sites.

Using multiple currencies

You can define a default currency for each customer and vendor. You can also define customer or vendor currencies other than the default currency, to use for specific sets of customer and vendor transactions. The transaction currency is no longer required to be in the customer or vendor default currency.

The customer and vendor currencies might be different than your company's base (domestic) currency. CloudSuite Business makes this possible through these multi-currency features:

- Maintainable currency rates.
- Transactions that use either fixed or variable rates. To specify a fixed rate for a specific transaction, select the Fixed Rate check box in the transaction's form.
- Euro conversion tools.
- FASB52 compliance.
- Recognition of currency exchange rate gains or losses.
- Customer and vendor transactions can be maintained in the foreign currency but can quickly be translated to your domestic currency.
- Customer and vendor payments are in the currency of the associated bank. Customer payments can be entered in a currency other than the currency of the bank where the payment will be deposited. In that case, the currency will be converted to the currency of that bank.
- Your general ledger maintained in your domestic currency.

Customer amounts can be stored in the system in the customer's default currency. This affects customer orders, estimating, and A/R.

Vendor amounts can be stored in the vendor's default currency. This affects purchase orders and A/P.

In addition to the default currency specified for a customer or vendor, you can define other currencies for a customer or vendor. Certain types of transactions have been modified to support these additional currencies used for the transaction currency.

Thus, if two sites in different countries use the same vendor, but the vendor uses a different currency in each country, you can use the same vendor number in both sites, but specify a different currency to be used for specific types of transactions.

Cash accounts used in bank reconciliations may be stated in non-domestic currencies. Payments are in the currency of the associated bank.

All amounts in journals, ledger, inventory (price and cost), and the shop floor are always stated in domestic currency.

When amounts are posted into journals, they are translated into domestic currency.

Currency master data

Currencies are maintained in the Currency Rates form. Users can enter an unlimited number of date- and time-stamped currency exchange rates. They can also back-date these rates by entering a past date. There are two exchange rates entered:

- The buying rate is used exclusively in purchase orders and A/P.
- The selling rate is used exclusively in customer orders, estimating, and A/R.

In the Currency Codes form, users can specify formats for currency amounts, and accounts to use for currency gains and losses.

For better integration with other applications, we recommend that you use the standard ISO currency codes.

Applying payments

You cannot apply payments to invoices of other sites where the other sites do not have the same base currency as the site entering the payment to apply.

Financial statements

You can print financial statements in different currencies. The exchange rates used to print the report are the rates stored in the site/entity that contains the ledger records being processed. The translations are for display purposes only. No posting of any kind takes place and no gain or loss is calculated.

Translations are defined for each line of the financial statement. You choose to use the buying or selling exchange rate.

Realized and unrealized gains and losses

When a company that is headquartered in one (domestic) country executes a transaction with a company in another (foreign) country using a currency other than the domestic currency, one currency needs to be converted into another to settle the transaction. This conversion from one currency to another creates gains and losses depending on the currency exchange rate.

Realized currency exchange gains and losses can occur when full or partial payments are applied to voucher or invoice amounts.

However, if financial statements are prepared between the date of the original transaction (sale or purchase on account, for example) and the date of the cash receipt or cash payment, and the exchange rate has changed since the original transaction, an unrealized gain or loss must be recognized in the statements.

Consolidated financial statements with foreign subsidiaries

Before the financial statements of domestic and foreign companies are consolidated, the amounts shown on the statements for the foreign companies must be converted to domestic currency. Asset and liability amounts are normally converted to domestic currency by using the exchange rates as of the balance sheet date. Revenues and expenses are normally converted by using the exchange rates that were in effect when those transactions were executed. For practical purposes, a weighted average rate for the period is generally used. The adjustments (gains or losses) resulting from the conversion are reported as a separate item in the stockholders' equity section of the balance sheets of the foreign companies.

After the foreign company statements have been converted to domestic currency, the financial statements of domestic and foreign subsidiaries are consolidated in the normal manner. See the ledger consolidation information in "Entities" on page 41 for more information.

Physical requirements

Generally, it is best to keep all application databases that will be sharing data through transactional replication on the same database server or at least in the same physical data center.

See the *Infor CloudSuite Business Guide to Technology* for more information about the physical requirements of a multi-site system.

Using the same forms database for multiple sites

6

Do you need multiple forms databases? If so, which sites should each forms database be linked to?

Consider this information:

- If you have multiple sites, and they will be looking at the same version of the CloudSuite Business application and the Mongoose framework, it might make sense to link them all to a single forms database. This allows you to create form customizations that all the users at those sites would see.
- You might want to use different forms databases for different communities of users. For example, some users may need to see a set of custom forms or custom fields, and other users would not require them. This flow chart shows an example:

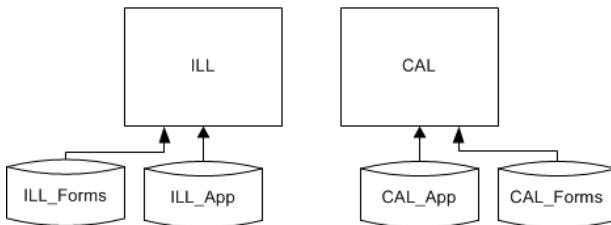

- However, using a single forms database, you can target customizations by group, as shown in this example:

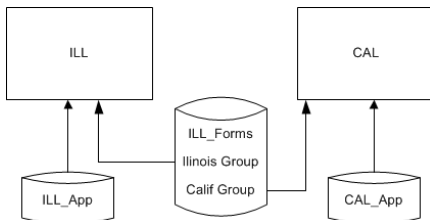

- Using one forms database for multiple sites can save space on your database server machine. And since forms database "traffic" is mostly read-only access, having many users/sites sharing a forms database usually does not present performance problems.

Updating the SiteEntity spreadsheet

Update your SiteEntity spreadsheet to specify the forms database to be used with each site.

Note: The CloudSuite Business configuration wizard will assume that the forms database name is the same as the application database name (for example, Crp_App would have a forms database called Crp_Forms). You can select a different forms database by changing the default value.

Background information

The forms database stores specifications for form components, validation procedures, scripts, variables, and other objects that make up the CloudSuite Business forms (in essence, the user interface). Data specified in design mode is stored in the forms database, and the framework interprets the data at run time to create the form.

The forms database includes a set of "strings" tables, which contain translations of the text strings used in form titles, field labels, buttons, and so on. The default strings table, for English, is named Strings. The other strings tables have names like JapaneseStrings, FrenchStrings, and so on. The strings table used for each language ID/culture is determined by the settings in the application's Language IDs form.

If you are customizing CloudSuite Business, we recommend maintaining a separate, work-in-progress forms database that is accessed by developers using WinStudio design mode. This work-in-progress database stores product changes until they are tested and ready to be copied to the deployed forms database accessed by end users.

The value you specify in the Forms Database Name field on the Sites or Sites/Entities form points to the forms database that contains the strings tables you want a specific site to use. The value in this field should match the Runtime Forms Database Name that is specified in the Configuration Manager utility for the primary configuration used to log into this site.

More information about the use of the forms database is available in the online help for the FormControl and FormSync utilities.

Using the same objects database for multiple sites

7

Do you need multiple objects databases, where the IDO definitions reside? If so, which sites should each objects database be linked to?

Considerations

Consider this information:

- IDO editor forms in Infor CloudSuite Business are used to create and maintain the IDOs metadata, which is then stored in the objects database and used by the IDOs at run time.

In versions of CloudSuite Business previous to version 8.00, IDO creation and maintenance was done through the ObjectStudio application, and the IDOs were stored as DLLs.

More information about the use of the IDO editor forms is available in the online help. These forms are accessible only with a separate "development" license.

During configuration, the objects database is specified for a site. The application database contains views into the objects database, so the runtime environment does not directly access the objects database.

- These are reasons to share a single instance of the objects database for multiple sites:
 - Any IDO patches, add-ons, or customizations are shared.
 - The application uses less disk space.
- You might not want to share an instance of the objects database across sites if the sites are in different data centers, and you do not want to pay the performance cost of accessing the objects database across a slow internet at run time.

Note: If you have multiple sites in a single application database, all of the sites must use the same objects database.

Updating the SiteEntity spreadsheet

Update your spreadsheet to specify the objects database to be used with each site.

	B	C	D	E	F	G	H	I	J	K	L	M
1	SiteName	SiteDescription	SiteType	AppDBName	Currency	TimeZone	SOLDBServer	Computer	Domain	SOLUser	FormsDBName	ObjectDBName
2	Corporate	Corporate Entity	Entity	Crp_App	USD	Central Stanc	MARS	MARS	USOLAR	sa	Crp_Forms	Crp_Objects
3	United States	United States Ent	Entity	USA_App	USD	Central Stanc	MARS	MARS	USOLAR	sa	Crp_Forms	Crp_Objects
4	Canada	Canada Entity	Entity	Can_App	CND	Eastern Stan	SATURN	SATURN	CASOLAR	sa	Can_Forms	Can_Objects
5	Illinois	Illinois Site	Site	Ill_App	USD	Central Stanc	MARS	MARS	USOLAR	sa	Crp_Forms	Crp_Objects
6	Ontario	Ontario Site	Site	Ont_App	CND	Eastern Stan	SATURN	SATURN	CASOLAR	sa	Can_Forms	Can_Objects
7	California	California Site	Site	Cal_App	USD	Pacific Stand	MARS	MARS	USOLAR	sa	Crp_Forms	Crp_Objects

Note: The CloudSuite Business configuration wizard will assume that the objects database name is the same as the application database name. For example, Crp_App can have an objects database called Crp_Objects. You can select a different objects database by changing the default value.

Background information

For more information about IDO maintenance forms and the objects database, see the online help.

Do you need multiple groupings of sites for different multi-site users or functions?

Consider this information:

- Site groups can be set up to combine data for sites performing related functions, for example, AR payment generation, inventory item availability, or subcomponent manufacturing. Sites in a group do not have to report to the same entity, but they must share the appropriate data through replication or shared tables.
- You can define groups containing different combinations of sites. A site can be included in more than one site group.
- On some activity, utility and report forms, you can select a site group, which allows you to process records for all sites in that group. If you want to process records only for the local site, you leave the site group field blank or, if the field is required, specify a group that contains just the local site.
- You can specify default site groups to use on certain types of forms (for example, A/P activities). You can also specify, for a specific user, the default site group to display when that user opens the Item Availability form.
- Site groups are used to determine which sites you can select when you copy records from one site to other sites in the Multi-Site Items, Multi-Site Customers, or Multi-Site Vendors forms.

Example

This flowchart shows an example of a site hierarchy:

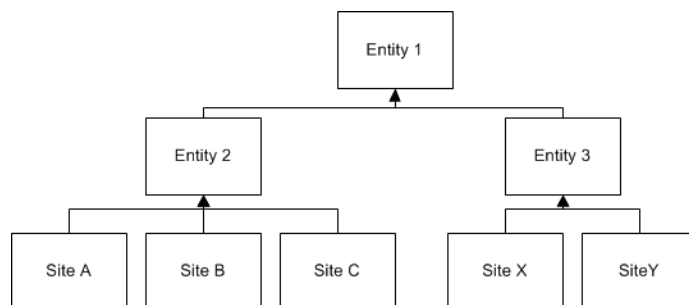

Grouping sites

A product manager is in charge of finished goods that are only manufactured at sites A and Y. All other sites produce sub-components. You can create a Site Group "AY", consisting of only sites A and Y.

Site Group "AY" can then be specified as the default site group for the product manager. Then when the product manager opens the Item Availability form, the system automatically defaults the Site Group field to "AY". In effect, this customizes the product manager's view of the system.

Creating a list of potential groups

Make a list of the site groups your system might use. Later, you can assign these groups to sites through the application's Site Groups form.

Updating the SiteEntity spreadsheet

Update your SiteEntity spreadsheet to specify which site group each site should initially belong to. An initial group is required when you configure the site.

	B	C	D	E	F	G	H	I	J	K	L	M	N
1	SiteName	SiteDescription	SiteType	AppDBName	Currency	TimeZone	SOLDBS	Computer	Domain	SOLUFormsDBName	ObjectDBName	SiteGroup	
2	Corporate	Corporate Entity	Entity	Crp_App	USD	Central Stan	MARS	MARS	USOLAR	sa	Crp_Forms	Crp_Objects	FIN
3	United States	United States Ent	Entity	USA_App	USD	Central Stan	MARS	MARS	USOLAR	sa	Crp_Forms	Crp_Objects	FIN
4	Canada	Canada Entity	Entity	Can_App	CND	Eastern Stan	SATURN	SATURN	CASOLAR	sa	Can_Forms	Can_Objects	CAN
5	Illinois	Illinois Site	Site	Ill_App	USD	Central Stan	MARS	MARS	USOLAR	sa	Crp_Forms	Crp_Objects	FIN
6	Ontario	Ontario Site	Site	Ont_App	CND	Eastern Stan	SATURN	SATURN	CASOLAR	sa	Can_Forms	Can_Objects	CAN

Background information

Review the additional information in "Background information" on page 17.

See the information on combined vs. consolidated reporting in "Entities" on page 41 for examples of how multi-site groups can be used.

This is an example of a form where you can select a site group in order to process records from multiple sites:

The screenshot shows a window titled "Cash Requirements Report" with the following elements:

- Options:**
 - Suppress Zero Records
 - Subtotal by Month
 - Print Open Payments
 - Display Report Header
 - Translate To Domestic Currency
- Filters:**
 - Site Group: FIN
 - Payment Hold: Both
- Payment Date:** 08/28/2007 Increment Date
- Starting:**
 - Due Date: [dropdown]
 - Vendor: [dropdown]
 - Name: [text box]
- Ending:**
 - [dropdown] Increment Date
 - [dropdown]
 - [text box]
- Buttons:** Preview, Print

The Intranet feature provides a way to logically show your LAN/database site setup from within Infor CloudSuite Business. Determine the number of intranets needed, decide on the intranet names, and decide which sites will belong to each intranet.

In most cases, you will need only one intranet. The exceptions are listed in this section.

Considerations

Consider this information:

- How are the sites physically connected? Generally all the sites on an CloudSuite Business logical intranet should be on the same physical LAN/intranet, especially if you plan to use transactional replication. Although it may be possible to run transactional replication between sites on different CloudSuite Business intranets, it is not recommended if the sites are connected by a slow or unreliable network connection.
- Will you have different versions of CloudSuite Business running at different sites? (This is not typical.) If so, they must be on different intranets.
- There can be only one master site per intranet. For information about using master sites, see "Sharing some data through master sites" on page 97.
- Are you planning to use intranet licensing, where you enter and maintain licensing information at one master site for all sites on the intranet? This concept is explained in the *Infor CloudSuite Business Licensing Administration Guide*.
- Will you have an external intranet, which allows integration, via replication, to applications other than those based on the Mongoose framework? Replication performed to a site on an external intranet must be non-transactional.
- Clients may be deployed to key customers or suppliers over the internet, allowing them access to specific system features. In this case, you probably should configure your web server components (and the URL for that server on the Intranets form) to use https instead of http, so that the data going over the internet is encrypted.
- Will you be pooling multiple utility servers through a Configuration server? If so, we generally recommend that a Configuration server and all its pooled utility servers, and all the clients using that Configuration server, be on the same intranet in the same datacenter, for high-speed, high-reliability connectivity. However, it is possible to have two intranets in the same datacenter (for

reasons of logical grouping) and use a single set of utility servers to make the configurations available to end users for sites on both intranets.

For more information, see "Configuration server" on page 73.

- Are you planning to have multiple sites send and receive business object documents (BODs)?
- How will TaskMan be configured to monitor sites on an intranet, especially in a setup with multiple utility servers? See "TaskMan monitoring of sites" on page 66.
- There can be only one replication queue listener defined per utility server. For non-transactional replication, each intranet requires a replication queue listener. Therefore, if you have multiple intranets in your data center, you must have one utility server for each intranet where the replication services are configured to monitor that intranet for non-transactional replication.
- If you have multiple sites in a single application database, and if the sites are sharing _all or user tables (through the Intranet Shared Tables or Intranet Shared User Tables utilities), then all sites in that database must be on the same intranet.

Reviewing your physical requirements

See the *Infor CloudSuite Business Guide to Technology*, or discuss with your CloudSuite Business provider, to determine your system's physical requirements

Physical requirements include the number of utility servers, web servers, clients, and so on. If you are using multiple utility or database servers, you may want to update your hierarchy flowchart to indicate which databases and configurations will be used on which servers.

Updating the SiteEntity spreadsheet

Update your SiteEntity spreadsheet to indicate the name of the CloudSuite Business intranet to which each site is connected.

	A	C	D	E	F	G	H	I	J	K	L	M	N	O
1	SiteID	SiteDescription	SiteTyp	AppDBNa	Curre	TimeZone	SQLDBS	Computer	Domain	SOLU	FormsDBNa	ObjectDBNa	SiteGroup	Intranet
2	CRP	Corporate Entity	Entity	Crp_App	USD	Central Stand	MARS	MARS	USOLAR	sa	Crp_Forms	Crp_Objects	FIN	USA
3	USA	United States Ent	Entity	USA_App	USD	Central Stand	MARS	MARS	USOLAR	sa	Crp_Forms	Crp_Objects	FIN	USA
4	CAN	Canada Entity	Entity	Can_App	CND	Eastern Stan	SATURN	SATURN	CASOLAR	sa	Can_Forms	Can_Objects	CAN	CANADA
5	ILL	Illinois Site	Site	Ill_App	USD	Central Stand	MARS	MARS	USOLAR	sa	Crp_Forms	Crp_Objects	FIN	USA
6	ONT	Ontario Site	Site	Ont_App	CND	Eastern Stan	SATURN	SATURN	CASOLAR	sa	Can_Forms	Can_Objects	CAN	CANADA

Note: The sample spreadsheet in the Multi-Site Tools ZIP file includes additional columns for the Cloud Suite Business base version and "Patched To" version. Although this information is not required for initial setup, knowing the current base and patch version will be valuable later as you maintain and update your sites.

Try to keep this spreadsheet up to date.

Background information

Review this information.

About intranets

CloudSuite Business intranets represent logical groupings of sites in your enterprise. An intranet may represent a grouping of CloudSuite Business sites that exist together on a high-speed network, and for which you want common administration. (Common administration can include replication or creation of master sites.) An intranet may also represent an external non-CloudSuite Business system, allowing you to set up replication rules between CloudSuite Business sites and external systems.

Use the Intranets form in the application to define information about your logical intranets. Then use the Sites or Sites/Entities form to assign your sites to an intranet.

For example, if you have two sites in one datacenter and two sites on a different datacenter, define two intranets, one for each datacenter, and put the sites from each datacenter on those intranets.

External intranet

Create an external intranet if you need to set up replication between sites on one of your CloudSuite Business intranets and an external system or an application.

For example, you might use an external intranet to connect to the Enterprise Financials application.

For such external systems or applications, the only attributes that matter will be the intranet name (so you can define "sites" on the Sites or Sites/Entities form that represent instances of external systems), the transport method (see below), and the URL. When you have defined sites on such an external intranet, you can then create replication rules. See "Frequency of data replication" on page 107. The replication system will dispatch XML documents to the URL you have specified on the intranet.

An CloudSuite Business site can communicate with an external site when it is on a different intranet, as shown in this example:

MyCORP (Internal) Intranet: SiteA SiteB (master site) SiteC

SunSystems Intranet (Enterprise Financials): SUNBU1 site

InforBUS Intranet (BOD-enabled applications): InforBUS site

Each of these external sites must be on its own intranet because each application uses a different URL address.

CloudSuite Business SiteB could perform transactional replication with all the internal sites, and could perform non-transactional replication to all the external sites.

Transport method

Most sites on external intranets use HTTP transport protocol to communicate with CloudSuite Business sites. However, Infor BOD-enabled applications use the ESB transport protocol.

Sending or receiving Business Object Documents from multiple sites on an intranet

Consider this information.

Inbound and outbound BODs

You can specify a default configuration name for a site in the Sites or Sites/Entities form. Alternatively, you can create a configuration whose name exactly matches the local site name.

On the CloudSuite Business utility server, you specify configuration information on the **Replication** tab of the Service Configuration Manager utility:

- In the **Replicator/Inbound Bus Configurations** field, specify all of the configurations that can receive inbound or outbound messages from other sites on the intranet. The Replication Document Outbox form at each site collects outbound BODs for that site. The Replication Document Inbox form at each site collects inbound BODs for that site.
- In the **ReplQListener Queue Servers** field, set up a queue server name for every intranet in your system.

Note: If you are upgrading from a previous version and you already have replication set up through a "bootstrap" site, it will still work as it did in the previous version. The **Replicator/Inbound Bus Configurations** field contains one site set as the Master Site, and the **ReplQListener Queue Servers** field has the **Default** field selected.

The named queue is the same for the specification in the Service Configuration Manager as it is in the **Queue Server Name** field on the Intranets form. For example, if you want `utilityserver3\private$\MyQueues` to be looked at by ReplQListener, you would use that queue in the Service Configuration Manager as well.

Purging BOD information

Information from every inbound BOD, including sequencing information, is collected in a table in the application. This data constantly builds up and, over time, could cause performance issues. For this reason, system administrators should periodically use the Purge BOD Information form to purge information from that table. You can set up a background task to perform this function automatically.

You can also use the Replication Document Inbox/Outbox Purge Utility to clear out older BODs from the Replication Document Inbox and Outbox.

TaskMan monitoring of sites

The Infor Framework TaskMan service must be set up to monitor each site on which users will be executing reports, stored procedures, IDO methods, executables, or other background tasks.

Entities must be monitored, since financial reports can be run on them.

During installation, a shared folder called SyteLine is set up on the utility server. When you enter information on the Intranets form, you must specify the path to this shared folder as the TaskMan Path.

That path, which is used for all sites on the intranet, is usually set to \\utility_server\SyteLine, where utility_server is the server containing the shared folder.

Using the Service Configuration Manager on the utility server, you specify which configurations will be monitored by TaskMan on that server.

Using multiple utility servers

You may have more than one utility server with identical configuration settings, pointing at the same application databases. You can configure the TaskMan service on each of the utility servers so that TaskMan monitors the same configurations on each server.

One utility server could be used as a "report server" and would contain the shared folder SyteLine. That server would be used for processing all reports, background tasks, etc. for the entire system.

You can have more than one TaskMan service instance monitoring the same application database (ActiveBGTasks_mst table). Whenever task requests come in from a site, the appropriate utility server's TaskMan service would pick them up. The TaskMan services on all the utility servers would access the shared UNC path (specified in the TaskMan Path on the Intranets form).

When initiating TaskMan, the system calls a stored procedure to retrieve the TaskMan Path value; then all report task requests are based on that path.

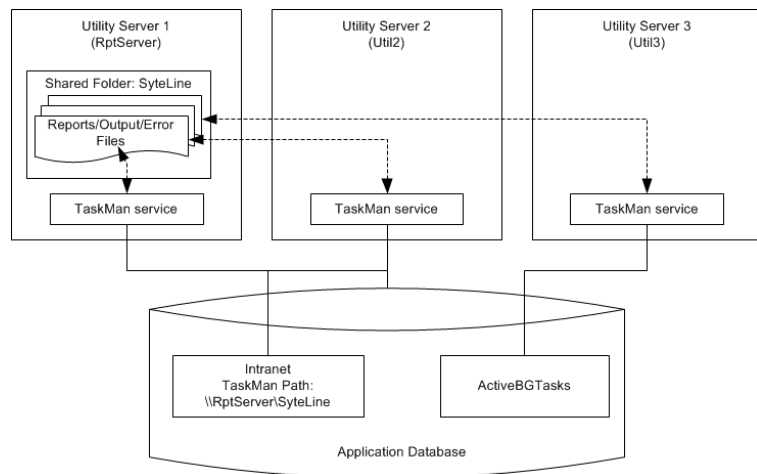

As long as each TaskMan service startup account has read/write privileges for the report server shared folder (\\RptServer\SyteLine), and the TaskMan Path for each site's intranet is pointing at the appropriate shared UNC path, the system can handle these tasks from any site:

- Look for requested report files on the report server
- Direct Microsoft SQL Server Reporting Services (SSRS) to generate output files in a specified output folder
- Create error/log files on the report server

The CloudSuite Business framework allows you to display forms in Web browsers. Two CloudSuite Business clients are available for use with browsers:

- The CloudSuite Business smart client via browser is available for use in Internet Explorer. It runs in a Windows environment and requires a small footprint on the client machine.
- The CloudSuite Business Web client can be used with most popular internet browsers. It has a zero footprint.

This chapter describes the use of the Web client, not the smart client via browser.

Considerations

Consider this information:

- Do you want your users to be able to view forms through the Web client? Reasons your users may want the web client as opposed to the smart client include access on computers that require a zero client footprint (no file downloads), non-Windows computers, mobile devices, or use inside Infor Ming.le.
- If you do want to include the Web client, do you want it to be run from a utility server that is also performing other work, such as servicing the smart client or running TaskMan, or do you want to set up a dedicated utility server for the web rendering engine?

Although firm guidelines are not defined, if you expect a very high volume of your users to use the Web client, then you might want to dedicate a utility server for this purpose.

- Use the DMZ Server installation option in deployments where the IDO Request Service and WSWebClient web applications are installed on a machine without the full utility server components. You can choose this option if you do not want to expose your utility server directly to the internet and do not want to place a load balancer or other hardware between the utility server and the internet.

Actions

If you want to use the Web client, identify the utility servers that will run the client. Include the Web client option when you install CloudSuite Business on that utility server.

After installation, you must provide the Web client login URL, which includes the server name, to your Web users.

For more information about the installation and setup of the Web client, see the *Infor CloudSuite Business Installation Guide*.

Do you need different sets of configurations to be available to different sets of users? Will you need multiple utility servers and thus a designated configuration server?

Considerations

Consider this information:

- Each site has at least one configuration defined for it through the Configuration Manager. Multiple configurations may be defined for one site.
- Configurations may be grouped to prevent users from accessing certain sites.
- You can designate one web/utility server as the Config Server.

Adding configuration names and groups to a spreadsheet

On the Sites/Entities form, specify a default Configuration Name for the site. You must create a configuration with this name, which will be mapped to this site record.

Alternatively, if you leave this field blank, you must create a configuration whose name exactly matches the local site name, including the capitalization. For example, if your local site name is oh, you must create a configuration named oh. You can use the Copy feature of the Configuration Manager utility to create this configuration

You might require multiple configurations, with different names, for one site.

If you plan to have only one client configuration for each site, then add the configuration name to the SiteEntity spreadsheet.

However, if you will have multiple configurations for the same site, create a new `Configurations` spreadsheet that contains this information:

- Configuration Name
- Configuration Group(s) to which it belongs
- Site
- Application Database
- Forms Database
- Objects Database
- Utility Server (or Configuration Server if pooling servers)

Determining the configuration groups that you need

You may want to restrict the list of configuration names that users see to a subset of the defined configurations. See the background information for details.

Determining which server is the configuration server

In a large multi-site system, you may have multiple web/utility servers. In this case, a designated Configuration Server is required. Read the background information to see how the Configuration Server is used.

Background information

Use this information to better understand the concepts.

Configuration names

You will be asked to create at least one client configuration name for each site. A site can have multiple configurations associated with it.

The configuration name is what the user sees and selects at login - so it should be descriptive and easily distinguished from other sites' configurations. For example, you might have two configurations for the ONT site called ONT_SALES and ONT_WHSE, using different forms databases but the same application database.

The maximum length for a configuration name is 50 characters and can include spaces. However, only the first 25 or so characters are displayed in the selection drop-down list on the CloudSuite Business

login screen. To allow users to see the entire configuration name, we recommend that you keep the names shorter than 25 characters.

Differentiation of configuration names should be obvious in the first five characters or so. This allows you to quickly distinguish between configurations when you have several CloudSuite Business sessions open at once.

Configuration server

In a large multi-site system, you may have multiple web/utility servers. In this case, a designated Configuration Server is required, because clients have one initial URL, pointing to a single machine. Only after users log in will the client session be directed to a member of the utility/web server pool.

GetConfigurations Request

This flow chart shows the flow of a request for a configuration:

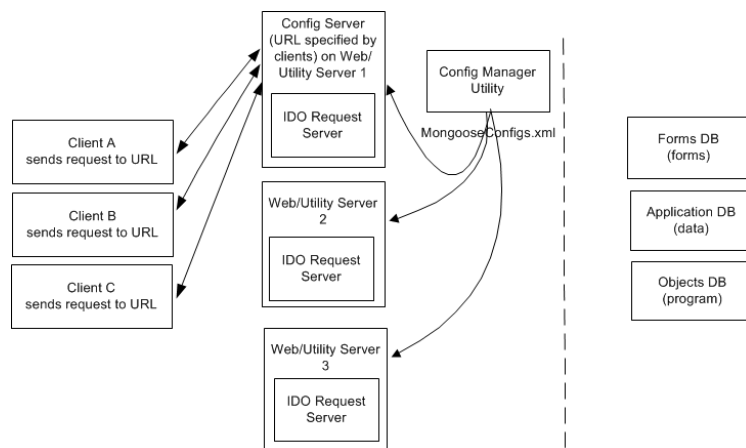

When a user logs into a CloudSuite Business session on a client, the system looks for a URL in either of these places:

- In the application shortcut’s properties, a -s parameter is followed by the URL, or
- In click-once client deployments, the URL is found in the ConfigServerURLs.xml file on the client.

The client sends a “GetConfigurations” request to this URL, which points to the ConfigServer.aspx page on a utility/web server that the administrator has decided to use as the "Configuration Server."

When this request comes in, the ConfigServer.aspx reads the MongooseConfigs.xml file, which also resides on the utility server. This XML (created with the Configuration Manager utility) contains information about these objects:

- Configurations: named combinations of specific application, forms, and objects databases.
- Applications: specifications of themes, etc.
- Web Servers: a list of available utility/web servers. Do not include DMZ servers in this list.

- Configuration groups: defined subsets of the full list of configurations available on a server.

Each time a GetConfigurations request comes in, ConfigServer.aspx picks a utility/web server from the list, in round-robin order; that is, it selects the next one in the Web Servers list in MongooseConfigs.xml.

It returns to the client the URL of the IDO Request Service on the selected utility/web server. This service can connect to all available configurations listed in its copy of MongooseConfigs.xml. The list is limited by the configuration groups the client can access.

IDO requests

For the remainder of that session, the client sends all requests to the specified IDO Request Service URL, which runs the request and returns the response back to the client, as shown in this flow chart.

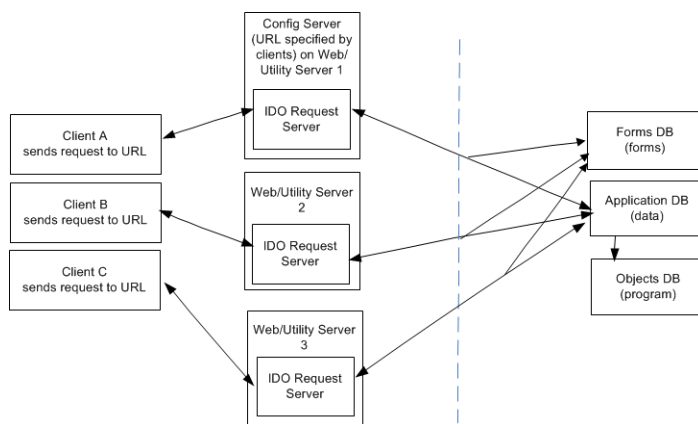

Designating a configuration server

Run the Configuration Manager utility only on the web/utility server that you want to designate as the Configuration Server. This creates the MongooseConfigs.xml file. Then copy that XML file to the same place on all other web/utility servers. Whenever you need to update configurations or your list of web servers, run Configuration Manager on the Configuration Server machine and redistribute the MongooseConfigs.xml file to the other servers.

On all clients, specify the same URL, which points to the web/utility server designated as the Configuration Server. For example: <http://server1/IDORquestService/ConfigServer.aspx>.

Configuration groups

When users start Infor CloudSuite Business, they are presented with a list of configuration names to select from. By default, this is a list of all the configurations that are defined on the Configuration Server. However, you may want to restrict the list of configuration names that users see to a subset of the defined configurations. For example, you could hide test, pilot or other configurations from users who should not access them.

You set up configuration groups, and specify the configurations that are members of each group, through the Configuration Manager utility. Then, when setting up clients, you can specify a group name as part of the connection information:

- If a client is using WinStudio on a utility server with no `-s` command line option, you can specify the configuration group using the `-gconfig-group` command line option. For example: `WinStudio.exe -gAcme`
- If a client is connecting to the Configuration Server using http, the configuration group can be specified as a query parameter in the URL. For example:
`http://slutil/IDORRequestService/ConfigServer.aspx?ConfigGroup=Acme`
- If you are using XML to connect, you can specify the configuration group name as part of the GetConfigurations IDO request. For example:

```
<IDORrequest>
<RequestHeader Type="GetConfigurations" ConfigGroup="Acme"/>
</IDORrequest>
```

See "Replication overview" on page 137 to get a general understanding about how replication works before you continue. Without that understanding, the replication planning steps probably will not make sense.

Considerations

Generally, the data that needs to be shared falls into one of the default replication categories - for example, Centralized Order Entry, G/L, or Inventory/Transfers. The default categories are described in the Background Information. These standard categories have been tested to ensure that they include all the necessary database tables, methods/stored procedures, and/or XML documents that must be included when replicating data for these areas of CloudSuite Business.

When you set up a multi-site system, you usually start by replicating the default categories between the sites where you think the information is required.

After your system is running, you might need to revise the rules, and possibly customize the categories, to achieve optimal performance based on your specific system's needs.

List the categories of data that need to be shared through replication, and the sites that need to share that type of data.

Does the data need to be shared in both directions?

Updating the flowchart

Update your flowchart with arrows indicating the categories of data being shared between the sites, and the directions the data is flowing.

See the sample flowchart in "Creating a flowchart that shows your hierarchy" on page 15.

Creating a ReplicationRules spreadsheet

Create a ReplicationRules spreadsheet listing each of the categories you think you will need, in each direction, from each site.

	A	B	C
1	Source Site	Target Site	Category
2	CAL	CAN	Site Admin
3	CAL	CRP	Ledger Consolidation
4	CAL	CRP	Site Admin
5	CAL	ILL	A/P
6	CAL	ILL	A/R
7	CAL	ILL	Centralized Order Entry
8	CAL	ILL	Inventory/Transfers
9	CAL	ILL	Site Admin
10	CAL	ONT	Centralized Order Entry
11	CAL	ONT	Inventory/Transfers
12	CAL	ONT	Site Admin
13	CAL	USA	Ledger Consolidation
14	CAL	USA	Site Admin

Do not specify whether the rules are transactional or non-transactional yet.

Background information

Use this information to better understand the concepts.

Replication with multiple sites per database

When you have multiple sites per database, tables are shared by the sites in that database. However, data is filtered by site. If you want a site to be aware of another site's specific data, you still must set up replication rules between the sites.



Default replication categories

The default replication categories included in CloudSuite Business are listed in the table below. More information about when to use each category is included in this section. See "Replication category tables" on page 145 for details about the stored procedures and tables that are included in each category.

If you choose to create new categories or modify existing ones, we strongly recommend that you get help from Infor Consulting Services. Determining all the relationships between tables and stored procedures is not a simple task. For example, the Centralized Order Entry category includes more than 90 tables and methods.

Note: Carefully consider which of the categories you actually need to replicate to each site. The more data being replicated, the slower the system's performance will be.

Some tables and objects exist in multiple categories; however, if you replicate these multiple categories to a site, only one set of table records is sent to the site.

Category	Create a source site-to-target site rule for this category in order to do this
A/P	View Accounts Payable posted transactions for the remote site Distribute A/P payments to remote site A/P posted transactions Include remote sites in A/P reports Share vendor addresses to the remote site
A/R	View Accounts Receivable posted transactions for the remote site Distribute A/R payments to remote site A/R posted transactions Include remote sites in A/R reports Share customer addresses to the remote site
CCI Centralized Order Entry	Use with the Centralized Order Entry category to support the use of the Credit Card Interface with centralized order entry.
Centralized Order Entry	Enter order lines to be shipped from the remote site Enable global item defaulting with the remote site View available inventory for the remote site Share customer addresses to the remote site
Customer Portal	Provide multi-site item pricing for Customer Portal and Reseller Portal. Allow the portal User Account Management Utility to create user accounts across sites
Dimensions	Share dimensions and attributes created at other sites. Site-specific information such as account numbers is not replicated.
ESB	Support the import and export of Business Object Documents (BODs) to and from Infor BOD-enabled applications.
EXTFIN	Support the export of A/P, A/R, Analytical Ledger, and Ledger posted transactions to an external financial application (the remote site is the site representing the external financial application).
	 Caution: This category should only be used in rules for transferring data to an external financial application.
EXTFIN Customer	Support the export of customer data to an external financial application (the remote site is the site representing the external financial application)
	 Caution: This category should only be used in rules for transferring data to an external financial application.

Category	Create a source site-to-target site rule for this category in order to do this
EXTFIN Vendor	<p data-bbox="500 331 1419 401">Support the export of vendor data to an external financial application (the remote site is the site representing the external financial application)</p> <div data-bbox="500 415 1419 548" style="background-color: #e6f2e6; padding: 5px;">  Caution: This category should only be used in rules for transferring data to an external financial application. </div>
G/L	<p data-bbox="500 569 1419 600">Support multi-site G/L reporting of data for the remote site</p> <p data-bbox="500 611 1419 642">Perform financial reporting by site group</p> <p data-bbox="500 653 1419 688">Support site/entity relationships between the local site and the remote site</p>
Initialize _All Parameters	<p data-bbox="500 709 1419 810">Quickly select all parameter tables during multi-site replication setup. See the <i>Infor CloudSuite Business Multi-Site Implementation Guide</i> for more information.</p>
Inventory/ Transfers	<p data-bbox="500 831 1419 863">View available inventory for the remote site</p> <p data-bbox="500 873 1419 936">Support the setup of inter-site parameters between the local site and the remote site</p> <p data-bbox="500 947 1419 978">Enable multi-site transfer functionality with the remote site</p> <p data-bbox="500 989 1419 1020">Enable global item defaulting with the remote site</p>
Invoice Builder	<p data-bbox="500 1041 1419 1104">Generate, print and post invoices for customer order shipments and returns in multiple target sites from a base site.</p>
Journal Builder	<p data-bbox="500 1125 1419 1188">Enter pending multi-site journal entries at the local site and validate the information from the remote site.</p>
Ledger Consolidation	<p data-bbox="500 1209 1419 1314">Pass G/L data needed only for ledger consolidation. This is a subset of the G/L category that does not include journal and ledger tables; if you are already replicating the G/L category, do not replicate this one.</p> <p data-bbox="500 1325 1419 1356">Support site/entity relationships between the local site and the remote site</p>
Ledger Detail	<p data-bbox="500 1377 1419 1409">Support viewing ledger detail for transaction data stored at the remote site.</p>
Manufacturer Item	<p data-bbox="500 1430 1419 1461">View manufacturer item information that was created in another site.</p> <p data-bbox="500 1472 1419 1535">View another site's cross-reference information between manufacturer item records and CloudSuite Business item records.</p>
Multi-Site BOM Builder	<p data-bbox="500 1556 1419 1619">Use with the Multi-Site BOM Builder form, to support the copy of item BOMs from one site to other sites.</p>
Multi-Site Buyer	<p data-bbox="500 1640 1419 1671">Support multi-site information on the Buyer Home form.</p>
Multi-Site Controller	<p data-bbox="500 1692 1419 1724">Support multi-site information on the Controller Home form.</p>
Multi-Site CRM	<p data-bbox="500 1745 1419 1776">Support multi-Site CRM information on the Salesperson Home form.</p>
Multi-Site Customer Service	<p data-bbox="500 1797 1419 1829">Support multi-site information on the Customer Service Home form.</p>

Category	Create a source site-to-target site rule for this category in order to do this
Multi-Site Customers	Support use of the Multi-Site Customers form from a master site.
Multi-Site Inventory Control	Support multi-site information on the Inventory Control Home form.
Multi-Site Items	Support use of the Multi-Site Items form from a master site.
Multi-Site Production Planner	Support multi-site information on the Production Planner Home form.
Multi-Site Project Manager	Support multi-site information on the Project Manager Home form.
Planning	<p>Pass Planned Supply created by the (single-site) Planner to the supply site as planned transfer demand - for items flagged as Transferred and containing a Supply Site</p> <p>View planning requirements and receipts for remote sites.</p>
PO - CO Across Sites	Support the ability for demand from one site to be satisfied by another site in a purchase order-customer order relationship.
Purchase Order Builder	Enter builder purchase orders at the local site and validate the information from the remote site.
Service - Global Incidents	Ensure that incidents that are updated in one site are synchronized to another site.
Service - Global Scheduling Shared Partners	Replicate tables related to both appointments and partners.
Service - Global Service History	View service information from multiple sites together on the Service Console.
Service - Global Units	Ensure that units that are updated in one site are synchronized to another site.
Service - Multi-Site SRO Copy	Cross-reference lines, operations, reasons, and planned transactions of the specified service order from one site to another and create a new service order in another site.
Shared Currency	Share currency and currency rate data with the remote site.
Site Admin	<p>Support setup of inter-site parameters</p> <p>Share site/entity data, including intranet data and site group data, with the remote site.</p>
Vendor Portal	Allow the portal User Account Management Utility to create user accounts across sites.
Voucher Builder	Create vouchers and adjustments in other sites based on information from those sites.

Replicating Site Admin

Replicating the Site Admin category between sites/entities allows them to share information about linked sites/entities, intranets, and system types. This should be the first category you replicate once you set up your multi-site system.

We recommend that, if you are replicating any data between CloudSuite Business databases, you always include a rule to replicate the Site Admin category. This applies to both entity and site databases, and the rules should be written to replicate the Site Admin data in both directions.

This flow chart shows an example:

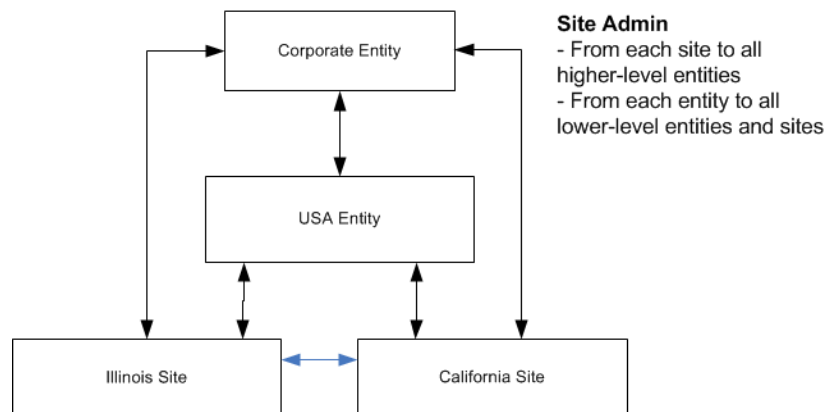

Replicating A/P and A/R

The A/P and A/R categories are generally replicated between sites. These categories allow you to handle the payment of an invoice or voucher from another site, and to centralize cash applications. You can also view A/P or A/R posted transaction details for multiple sites.

You will need to specify liability and asset accounts for inter-site payments on the **Payment** Tab of the Inter-Site Parameters form.

This flow chart shows an example:

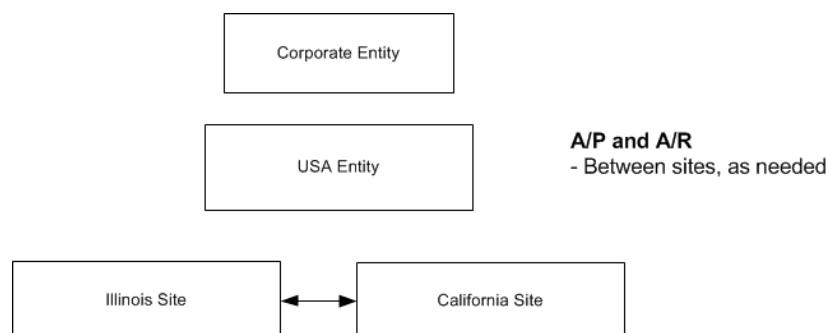

Replicating multi-site information for Home forms

These categories allow you to view related information from other sites in the appropriate Home form:

- Multi-Site Buyer
- Multi-Site Controller
- Multi-Site CRM (Salesperson Home)
- Multi-Site Customer Service
- Multi-Site Inventory Control
- Multi-Site Production Planner
- Multi-Site Project Manager

Replicating Manufacturer Item

The Manufacturer Item category is generally replicated between sites. Manufacturer item records contain cross-referenced information about your CloudSuite Business items and various manufacturers' items. This category allows you to view the source site's information at a target site.

Replicating Centralized Order Entry and Inventory/Transfers

The Centralized Order Entry and Inventory/Transfers categories are generally replicated between sites. For a better understanding of how the Centralized Order Entry and Inventory/Transfers categories may be used, see "Centralized and decentralized order entry" on page 50.

For these categories, you must specify some intra-entity and inter-entity account numbers on the Inter-Site Parameters form.

When you replicate A/R or Centralized Order Entry, the `custaddr_mst` table is replicated. Thus, when a user in the Customers form at any site updates certain customer information such as the billing address, the change is made for that customer at all other sites. You may want to set up CloudSuite Business authorizations to limit the users who can modify customer information. The same thing is true for the A/P category and the `vendaddr_mst` table.

Replicating credit card information

If you have a multi-site system with centralized order entry and the Credit Card Interface is available, your users can enter and validate credit card information from a centralized site, and then later charge the card from a different shipping site where the invoice is generated. Be aware of these rules:

- This feature does not apply to service orders, only to customer orders

- Your company must have a single merchant account that is used by all of your sites. Therefore, the gateway access and other settings in the CCI Parameters form must be the same in every site.
- Stored credit card information is not replicated. It is stored only at the order entry site.

To turn on this feature, use these steps:

- 1 Ensure that replication rules are created that include both of these replication categories:
 - Centralized Order Entry
 - CCI Centralized Order Entry
- 2 On the Replication Rules form, set up the shipping sites as target sites that receive both rules from the centralized order entry (source) site, and regenerate the replication rules at all sites.
- 3 When a user clicks **Pay with Credit Card** during order entry, if a successful authorization is received, the system replicates that authorization information to each of the sites that are set up to receive this replication category.

Sharing vendors, customers, or items between sites

You might want an administrator to control adding, updating, and deleting of shared customers, vendors, and items across the system. Keep in mind that each site can control its local customer and vendor records, and these records are independent of other sites.

Shared vendors

If you have a master site, use the Multi-Site Vendors form at the master site to add and update multi-site vendor records for all sites on the intranet. The A/P, Ledger Consolidation (or G/L) and Inventory/Transfers categories must be replicating in order to use this form.

If no master site is required, but if A/P replication is set up between sites, some vendor data is replicated to other sites when a new vendor is added at one site. The new record does not automatically appear in the Vendors form at the other sites. However, the new vendor number does appear in the drop-down list when you start to add a new vendor at the other sites - so you can select it and add a new record for it. This ensures that the vendor number is the same at all sites.

Any changes made to the vendaddr records in one site are automatically replicated if the vendor number exists in the other site and the A/P category is replicated. Note that the vendaddr_mst table contains other information in addition to the vendor's address.

The currency code cannot be changed for a vendor after the record is saved. However, an additional vendor record can be added with the new currency code.

Shared customers

If you have a master site, use the Multi-Site Customers form at the master site to add and update multi-site customer records for all sites on the intranet. The Site Admin and Multi-Site Customers categories must be replicating in order to use this form.

If no master site is required, but if A/R or Centralized Order Entry replication is set up between sites, some customer data is replicated to other sites when a new customer is added at one site. The new

record does not automatically appear in the Customers form at the other sites. However, the new customer number does appear in the drop-down list when you start to add a new customer at the other sites - so you can select it and add a new record for it. This ensures that the customer number is the same at all sites.

Any changes made to the custaddr records in one site are automatically replicated if the customer number exists in the other site and the A/R or COE category is replicated. Note that the custaddr_mst table contains the customer's credit information as well as the address and other information.

The currency code cannot be changed for a customer after the record is saved. However, you can specify additional currencies for the customer, to be used with specific transactions.

Using Credit Hold in a Multi-Site Environment

In a multi-site environment, the originating site of a customer order controls the credit hold status of the customer order for all sites from which the customer order may be shipped. Also, when you initiate the Order Credit Hold Change Utility in a multi-site environment, the system performs the processing at all sites for the selected customers.

CloudSuite Business checks the customer's credit limit to determine if it is exceeded to determine whether to use credit hold:

- If a customer's credit limit is exceeded and the shipping site is the originating site of the customer order, the order is placed on credit hold.
- If a customer's credit limit is exceeded and the shipping site is not the originating site of the customer order, a warning message displays, but the customer order is not placed on credit hold.

Shared items

If you have a master site, use the Multi-Site Items form at the master site to add and update multi-site item records for all sites on the intranet. The Site Admin and Multi-Site Items category must be replicating between the sites in order to use this form.

If no master site is required, and Inventory/Transfers replication is set up between sites, some item data is replicated to other sites when a new item is added at one site. This data appears in the Global Items form. The Global Items form also contains a default Shipping Site, which is used to determine how the Customer Order Line ship site defaults when entering a centralized order for the item. Typically, replicating sites have identical Global Items default values when all sites are within the same country. If sites are in different countries, the **Description** and **U/M** fields can be updated as required on Items records.

The new record does not automatically appear in the Items form at the other sites. However, the new item number does appear in the drop-down list when you start to add a new item at the other sites - so you can select it and add a new record for it. This ensures that the item number is the same at all sites.

Coordinating units of measure at different sites

Item units of measure (U/M) are handled differently for customer order entry and transfer orders:

- Transfer Orders: Items on transfer orders must have identical U/Ms at all sites.

- Order Entry: It is not necessary to have the same U/M defined at different sites, as long as the shipping site has defined a U/M conversion between the item's base U/M and the U/M used in the order line.

If an item could be both sold on a customer order and transferred between sites, then the item must have identical units of measure at each site.

Replicating item routing and BOM information

Use the Multi-Site Bill of Material Builder utility and the Multi-Site BOM Builder replication category to copy an item's bill of materials from a site to other sites. The Builder copies a single level at a time. For more information, see the help on copying a multi-site item bill of materials.

Replicating financial information

Use the information in this section to decide when to replicate these categories:

- G/L
- Ledger Detail
- Ledger Consolidation

Note: Be aware that replicating the G/L and Ledger Detail categories can create thousands of (possibly unnecessary) records at the target site and can send large amounts of data over your intranet, affecting system performance.

From entities to child entities or sites

Ledger Consolidation is a subset of the G/L category. In order to push Chart of Accounts, Accounting Periods, and Budget/Plan data from the entity to its child sites, you must replicate either the G/L or Ledger Consolidation category. Generally you should use the Ledger Consolidation category when replicating from an entity to another entity or to a site, because you do not need to view the entity's journal or ledger information at the other entity/site. Less data is transmitted between the systems, which results in better system performance.

This flow chart shows an example of Ledger Consolidation replication:

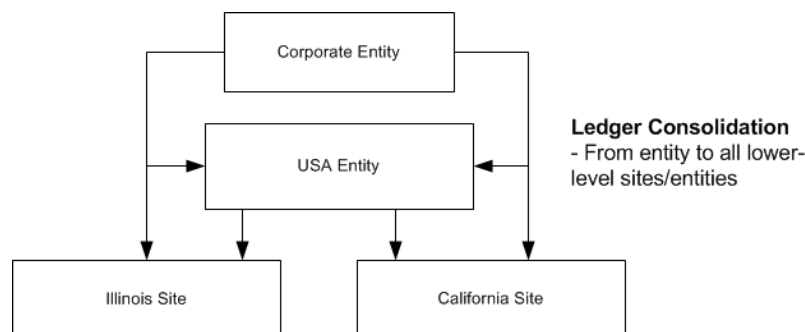

From child sites or entities to a parent entity

Financial statements require balance information, which is calculated using data from the ledger. So if you want to run a financial statement at an entity that includes data from another entity or site, consider this:

- When you run a financial statement at the entity and specify a Site Group, the entity looks at replicated data, so you would need to use the G/L category when replicating from child sites/entities to this entity.
- When you run a financial statement at the entity and leave the Site Group blank, the entity looks at the consolidated records created via the Ledger Consolidation utility. (When you use the Ledger Consolidation utility to consolidate information from a site to an entity, the utility copies the ledger table to the parent entities, altering the hierarchy column to reflect the Entity path from the Site, converting amounts to the Entities' currency, and possibly creating new ledger transactions to reflect currency rounding differences.) So if you never specify a Site Group at the entity, use the Ledger Consolidation category when replicating from sites/child entities to this entity.
- If you sometimes specify a Site Group and sometimes do not, use the G/L category when replicating from child sites/entities to this entity. That way the data will be available at the entity when you need it.

If you need to "drill down" to view a site's transaction details at the remote site, then replicate the Ledger Detail category as well as the G/L category. This assumes that any other categories required for the transaction-level detail are also being replicated; for example, viewing detail for invoice transactions may also require replication of the A/R or Centralized Order Entry categories. It may be better (from a performance standpoint) to just log into the site where the transaction occurred and view the detail there.

If you will perform Budget Consolidation, either Ledger Consolidation or G/L replication is required from sites to the parent entities, as shown in this flow chart:

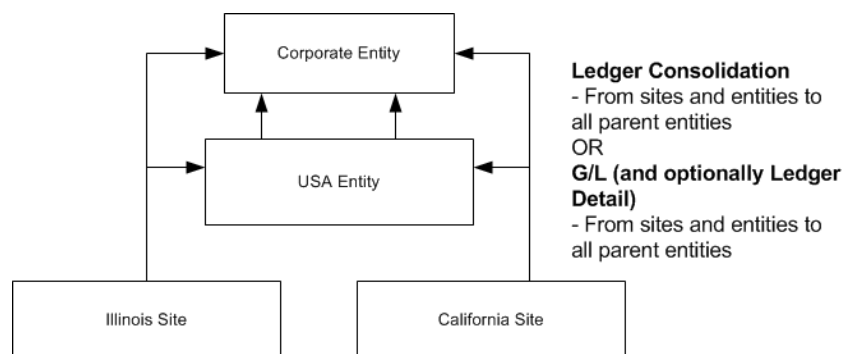

Using the Change Reports To Entity utility

The Change Reports To data is replicated in the G/L or Ledger Consolidation categories, and the **Reports To** field is replicated in the Site Admin category. Set up replication so that your highest-level entity displays **Reports To** information in the Sites/Entities form for all sites and lower-level entities.

Between sites

General ledger data rarely should be replicated between two non-entity sites.

Unit codes

The `unitcd[1-4]_mst_all` and `chart_unitcd[1-4]_mst_all` tables are replicated in the G/L category. The Ledger Consolidation replication category contains a stored procedure that inserts information into the `unitcd[1-4]_mst` tables based on the unit codes within ledger rows that are consolidated. (Unit code information is included when you run the Ledger Consolidation utility.)

The `unitcd[1-4]_mst_all` table is included in other financial replication categories such as A/P, A/R, Journal Builder, and Purchase Order Builder.

The Inventory/Transfers category also includes `unitcd[1-4]_mst_all` and `chart_unitcd[1-4]_mst_all` tables. This allows visibility of unit codes from remote sites on the Inter-Site Parameters form.

Replicating dimensions

Replicate the Dimensions category if you want users to view dimensions and attributes that were created at other sites. Because the replicated tables are not `_all` tables, this data is being "shared" between the source and target sites. If updates are made at the source site, these updates are made to the tables in target sites.

Site-specific information such as account numbers is not replicated. For more information about dimensions and attributes, see the online help.

Replicating shared currency

Depending on how your system handles currencies between sites, the Shared Currency replication category can be used to permit sites and entities to share currency definitions and exchange rates; otherwise, each site maintains its own currency codes and rates.

The domestic currency must be the same at all sites reporting to an entity. However, you may set up the sites so they can maintain their own currency exchange rates - or you may want to maintain the exchange rates only at the entity:

- If currency and rate maintenance is performed only at the entity, you should replicate the Shared Currency from the entity down to the reporting sites. You do not need to replicate the Shared Currency category up from the sites to the entity. You must then disable the ability to change Currency Rates at the sites, in order to maintain control over the data. This flow chart shows an example of this option:

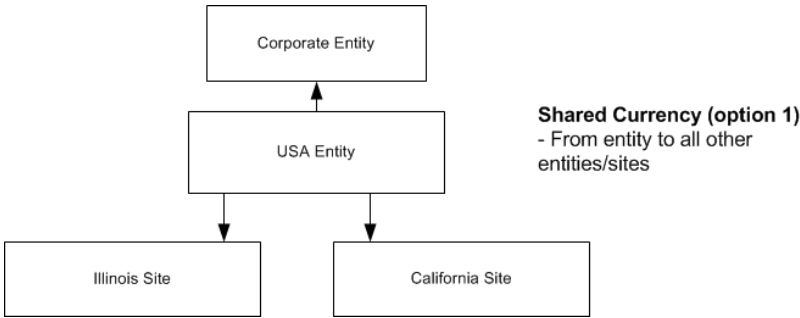

- If currency and rate maintenance is performed at sites, then you should replicate the Shared Currency category from the sites up to the entity to which the sites report (and not back down to the sites from the entity). When using this setup, sites within the same reporting structure should also replicate currency and rate information between the sites. This flow chart shows an example of this option:

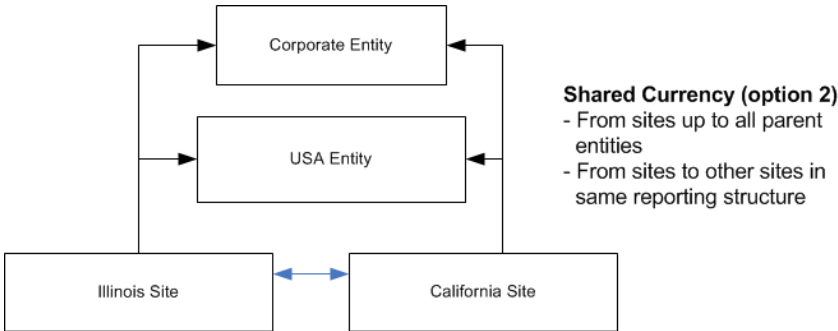

Although this category replicates base tables, updates to the tables at one site/entity are only replicated to other sites/entities if there is a replication rule between them. (Replication is point-to-point.)

You could also set up your system to have only one site maintaining the currency codes, in which case you would have one-way replication rules from that site to all other sites and entities.

Replicating planned transfer orders (Planning)

The MRP and APS systems generate planned transfer supply orders (PLNs) for any components provided by remote supply sites. The due date on these PLNs will be based on each item's lead time and transit time. To generate the corresponding planned transfer demand, or TPLN, at the supply site (that is, for the supply site to "see" this demand), you must set up the system to replicate the planned transfer order to the supply site.

In the Replication Rules form, you define the receiving site and supply site for replicating the transfer orders:

- The Source Site must be the receiving site (the site where the demand originates).

- The Target Site must be the supply site that produces the component. This should be the same site defined as the Supply Site on the item record. The planned transfer order will be replicated at this site.

Additional notes:

- Multiple planned transfer demands are consolidated before being replicated to the supply site.
- When you replicate the Inventory/Transfers category, supply and demand transfer orders are synchronized; that is, a demand transaction at one site precedes the related supply transaction at the other site. However, if you also replicate the Planning category, planned transfer orders do not need to wait for a transfer order transaction from the other site, as demonstrated by this example:
You run planning (either MRP or APS) at the receiving site. At the supply site, the planned transfer demand (TPLN) is automatically generated, with an XFD reference, as soon as it arrives – without having to firm a transfer order. In this way, the receiving site has immediate visibility of the TPLN ahead of the true Transfer Order. (With APS, the TPLN is incrementally planned.) The resulting projected date for the order is not replicated back to the receiving site that generated the demand. At the receiving site, when you firm the planned transfer supply order into an actual transfer order, the system replicates that transfer order to the supply site and deletes the TPLN.
- The due date on a planned transfer order reflects transit time.
- Sites running MRP Planning can replicate transfer orders to sites running APS Planning. Sites running APS Planning (in single-site mode) can replicate transfer orders to sites running MRP Planning. However, sites running APS Planning in Global mode cannot replicate transfer orders to MRP sites.

This flow chart shows an example of Planned Transfer replication:

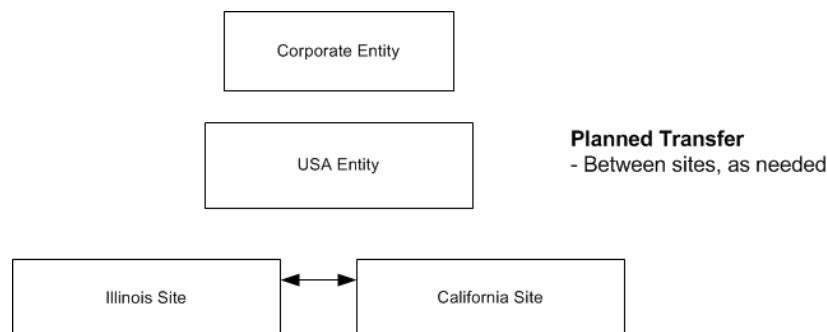

Replicating external financial (EXTFIN) data

CloudSuite Business provides an XML-based interface that can be used with an external financial system such as SAP.

Note: The EXTFIN interface is not the same as the Infor CloudSuite Business Enterprise Financials interface, which interfaces with SunSystems and which uses a custom set of replication categories. For more information about this interface, see "Enterprise Financials (SLSI)" on page 120. EXTFIN is also not the same as the Infor Global Financials (IGF) interface, which uses direct data access.

You can choose the types of financial information to export or import between CloudSuite Business and the other system. These are the default External Financial categories:

- **EXTFIN:** Used for exporting CloudSuite Business A/R, A/P, and G/L transactions to the external financial system, and also for exporting requests for updates to CloudSuite Business tables by the external financial system. This category includes the functions and XML documents required to export financial information:
 - **ExtFinAPVoucherPosting:** Exports data from the CloudSuite Business `export_aptrx_mst` and `export_aptrxd_mst` tables, which are holding tables for data collected from various A/P tables.
 - **ExtFinARInvoicePosting:** Exports data from the CloudSuite Business `export_arinv_mst` and `export_arinvd_mst` tables, which are holding tables for data collected from various A/R tables.
 - **ExtFinAnaLedgerPosting:** Exports data from the CloudSuite Business `ana_ledger_mst` table.
 - **ExtFinLedgerPosting:** exports data from the CloudSuite Business `ledger_mst` table.
 - **ExtFinRequest...:** Exports a request to the external financial application for updates to a specific CloudSuite Business table. See the help on the External Financial Interface Data Request Utility for more information
- **EXTFIN Customer:** Used for exporting CloudSuite Business Customer information. This category includes the sibling database tables `custaddr_mst` and `customer_mst`.
- **EXTFIN Vendor:** Used for exporting CloudSuite Business Vendor information. This category includes the sibling database tables `vendaddr_mst` and `vendor_mst`.

Rules that contain EXTFIN, EXTFIN Customer, or EXTFIN Vendor should be set up only where the "To" Site is a site that represents an external application.

When a new customer or vendor record is added in CloudSuite Business, the information is sent to the external financial system as two XML documents: one XML that contains new `customer_mst` or `vendor_mst` data but only key values for `custaddr_mst` or `vendaddr_mst` table records, and another XML document that contains new and old values for updated `custaddr_mst` and `vendaddr_mst` table records. For updates to existing customer or vendor records, the XML document pulls records only from the table that changed.

Initializing parameter table data

The Initialize _All Parameters category is only used with the Update _All Tables form, to simplify the selection of the parameter tables during replication setup. For more information about how to use this category, see the information about setting up replication in the *Infor CloudSuite Business Multi-Site Implementation Guide*.

Replicating Invoice Builder data

If you plan to use the Invoice Builder form to create invoices at other sites, set up these replication rules for the Invoice Builder category:

- From the site running the Invoice Builder to remote sites into which invoices will be inserted. This allows the creation of the invoices in the remote sites.
- From the remote sites to the Invoice Builder site. This replicates the necessary _all table data for validations performed on the Invoice Builder form.

In the Customer Order Lines and Customer Order Blanket Lines forms, users can specify a ship site. The item is shipped from this site even if the order is created at another site. Normally, the invoice is created at the ship site. For example, an order is created at the OH site, with two lines for Item X and Item Y. For item X, the ship site is OH, and for Item Y, the ship site is IN. The invoice for Item X is created in the OH site, and the invoice for Item Y is created in the IN site. However, if you have Invoice Builder replication set up, invoice creation and posting can all be done at the OH site, through the Multi-Site Invoice Posting form.

If you use the Invoice Builder, be aware of these requirements:

- In the target sites and the site where the Invoice Builder is being run, this information must match: base (domestic) currency, currency and quantity formats, cost/price formats, tax systems, and terms code tables.
- The same customers, customer addresses, and customer currency must be used at the Invoice Builder site and at the target sites.

Replicating Journal Builder data

If you plan to use the Journal Builder form to enter multi-site journal entries that will be created in other sites, set up these rules for the Journal Builder category:

- From the site running the Journal Builder to remote sites into which pending journal transactions will be inserted. This rule allows the processing of the pending journal transactions to the remote sites.
- From the remote sites to the Journal Builder site. This replicates the necessary _all table data for validations performed on the Journal Builder form.

Journal Builder use at an entity, or to enter transactions to be inserted at an entity, is not supported.

In the Journal Builder, transactions can be entered only for sites that use the same domestic currency as the local Journal Builder site.

Replicating Purchase Order Builder data

If you plan to use the Purchase Order Builder form to create purchase orders at other sites, set up these replication rules for Purchase Order Builder:

- From the site running the Purchase Order Builder to remote sites into which purchase orders will be inserted. This allows the creation of the POs in the remote sites.
- From the remote sites to the Purchase Order Builder site. This replicates the necessary _all table data for validations performed on the Purchase Order Builder form and for printing the Builder purchase order.

Be aware of these setup requirements for the Purchase Order Builder:

- These characteristics must match in the target sites and the site where the Purchase Order Builder is being run: base currency, currency and quantity formats, terms code table, tax system setup, tax parameter setup, tax codes assigned to vendors, and tax codes assigned to items.
- On each purchase order related to the same Builder PO, the system assumes that the same terms code, buyer, Remit To address, vendor contact, and LCR number are used.
- Vendors must be set up to use the same currency in both target and PO Builder sites.
- The target sites must have the same U/M Conversion factors as the PO Builder site.
- Transactional replication is required.

Replicating Voucher Builder data

If you plan to use the Voucher Builder form to create vouchers and adjustments at other sites, set up these replication rules for the Voucher Builder category:

- From the site running the Voucher Builder to remote sites into which vouchers and/or adjustments will be inserted. This allows the creation of the vouchers and/or adjustments in the remote sites.
- From the remote sites to the Voucher Builder site. This replicates the necessary _all table data for validations performed on the Voucher Builder form.

If you plan to use the Manual Voucher Builder form to create a voucher in one or more sites for a single vendor's invoice, set up these replication rules for the Voucher Builder category:

- From the Manual Voucher Builder site to the remote sites into which pending voucher transactions will be created. This allows the setup of how the system will process pending voucher transactions.
- From the remote sites into which pending voucher transactions will be created to the Manual Voucher Builder site. This replicates the necessary _all table data for validations performed on the Manual Voucher Builder form.

Be aware of these setup requirements for the Voucher Builder:

- These characteristics must match in the target sites and the site where the Voucher Builder is being run: base (domestic) currency, currency and quantity formats, cost/price formats, tax systems, and terms code tables.
- The system requires that the same vendors, vendor addresses, and vendor currency are used at the Builder Voucher site and at the target sites.

Be aware of these setup requirements for the Manual Voucher Builder:

- These characteristics must match in the target sites and the site where the Manual Voucher Builder is being run: base (domestic) currency and currency formats.
- The system requires that the same vendors, vendor addresses, and vendor currency are used at the Builder Voucher site and at the target sites.

Replicating Customer and Vendor Portal data

All sites in the portal site group must be linked and replicated using standard replication rules. For the Vendor Portal, the A/P replication category must be replicated across all sites in the Vendor Portal site group. For the Customer Portal and Reseller Portal, the A/R, Centralized Order Entry, and Customer Portal replication categories must be replicated across all sites in the Customer Portal site group.

For more information about setting up multi-site portals, see "Portals" on page 125.

Replicating Service data

These replication categories are used with CloudSuite Business Service:

- Service - Multi-Site SRO Copy
- Service - Global Incidents
- Service - Global Service History
- Service - Global Units
- Service - Global Scheduling of Shared Partners

Incidents and units

Both the Service - Global Incidents and Service - Global Units categories allow you to set up replication rules so that incidents and units that are updated in one database are synchronized to another database. When you create a replication rule for either category, set the **Interval Type** to **Transactional**.

Note: Because customer information is included on an incident, the A/R replication category must also be replicated whenever incident replication is taking place.

Incident Reason and Resolution notes are replicated with the Service - Global Incidents category. Incident notes are not replicated.

Service Console

Use the Service - Global Service History category to set up replication rules so that service information from multiple sites can be viewed together on the Service Console form. The replicated data is read-only, so system performance and business processes should determine the replication interval setting.

Service orders

The Service - Multi-Site SRO Copy category is used with the Multi-Site Service Order Copy form, which copies all lines, operations, reasons, and planned transactions of the specified SRO from one site to another. Set the replication rule interval to Transactional.

Note: The service order copy utility only works between live-linked sites on the same SQL database server.

Global scheduling of shared partners

Global scheduling of shared partners can be performed by companies that have multiple back office sites but one pool of technicians (partners) who perform service work for all sites. The Service - Global Scheduling Shared Partners replication category replicates tables related to both appointments and partners. The replication rule interval should be set to Transactional.

The appointment reference is not replicated. If your company requires cross-site access to the appointment reference, you should implement scheduling by incidents and configure the system for global incidents.

The warehouse, department, work code, and misc code are not included in this replication category, because these values are optional (not required) for partner setup. If your company populates this information on the partner, you must ensure that the data exists in both sites. To do this, either implement manual data entry processes or leverage standard replication by creating a custom replication category that includes the tables to replicate.

Replicating data via BODs (ESB)

CloudSuite Business provides an XML-based interface that can be used to transmit data to and from other Infor BOD-enabled applications. This interface must be set up as described in the appropriate application's integration guide.

Rules containing the ESB replication category should be used only where the "To" Site is a site that represents BOD integration.

Recommended transactional replication rules

Infor Consulting recommends some standard rules for companies that use transactional replication.

Transactional replication and Update All Columns are explained in "Frequency of data replication" on page 107."

This table lists the recommended rules for entities:

Replication Category	To	Interval Type	Update All Columns
Site Admin	All Sites All Entities	Transactional	No
Ledger Consolidation **	Child Sites/Entities	Transactional	No
Shared Currency *	Child Sites/Entities	Transactional	No

This table lists the recommended rules for sites:

Sharing data between sites

Replication Category	To	Interval Type	Update All Columns
Site Admin	All Sites All Entities	Transactional	No
G/L or Ledger Consolidation **	Sites/Entities	Transactional	No
All Others (A/P, A/R, Central- ized Order Entry, Invento- ry/Transfers) as needed	Sibling Sites	Transactional	No

** See "Replicating financial information" on page 86 for your options.

* See "Replicating shared currency" on page 88 for your options.

See "Replication overview" on page 137 to get a general understanding about how replication works before you continue. Without that understanding, the replication planning steps probably will not make sense.

Considerations

You might decide to set up master sites and shared views into tables at the master site, instead of replicating tables, for some areas of your system.

If all your sites are in a single database, you are effectively sharing many database tables already. However, we recommend that you set a master site for the intranet, in order to maintain customers, vendors, and items for all sites from the master site. You can optionally use the Intranet Shared User Tables form to share the Authorizations_mst, UserGroupMap_mst, and/or user_local_mst tables if you want to share users and group authorizations information between sites. You should not use the Intranet Shared Tables form; those tables are already shared because the sites are all in one database.

If you have one or more sites in one database, and additional sites in the same intranet but not in the same database, you can use a master site and the Intranet Shared Tables feature to allow sharing between the sites in one database and the sites in other databases.

Advantages of using a master site

If you use a master site for certain functions, you have these advantages:

- Establish central global tables, many of which allow filtering by site
- Require less storage space – fewer records are replicated across the enterprise
- Use less background processing
- Simplify replication troubleshooting and querying of _all tables
- Provide a lighter load on database servers, thus better speed for end users.
- Centralize entry of customer, vendor and item records
- Centralize maintenance and validation of licenses if you are also using intranet licensing. See the information about intranet licensing in the *Infor CloudSuite Business Licensing Administration Guide*.
- Centralize maintenance of user and group information.

Physical requirements

- There can be only one master site for a CloudSuite Business logical intranet.
- Live links must be set up (on the Sites or Sites/Entities form) between the master site and the other sites in the intranet.
- Do not share _all or user tables across multiple SQL Server instances, because it may severely impact performance. We recommend that a master site and its subordinate sites reside on the same server in a linked SQL environment. If you have multiple SQL Server instances, you can set up one intranet per SQL Server instance name and use regular replication between the two master sites on those two intranets.
- If a master site exists and has a shared table, all sites on that CloudSuite Business intranet must share that table through views; you cannot have some sites sharing the table and some sites not sharing the table.
- If you have multiple sites in different application databases on one SQL server, then you can perform one of these tasks:
 - Set up transactional replication between the sites
 - Set up a master site that shares its tables with other sites on its intranet
 - Set up a combined system, where the master site holds some shared _all tables, but some other _all tables are replicated between the sites
- If you have multiple sites on separate servers or on separate intranets, non-transactional replication is probably a better choice.
- If multiple sites exist in one database, then it is not possible to share tables in one site without sharing tables in all sites in that database.
- Consider the load on the database used for the master site and the number of users/sites that will need to access the master site. In large multi-site systems, you may want to designate a site to be used only for that purpose, for better system performance.

For example, you might not want the master site also to be used as a production manufacturing site.

Updating the flowchart

Update your flowchart with boxes for any master sites. These boxes should indicate somehow - through shading or color, perhaps - that they are master sites.

Indicate shared data that resides at the master site - either by replication category or by table name. Use a different type of arrow, perhaps thicker or a different color.

This flow chart shows an example with a master site:

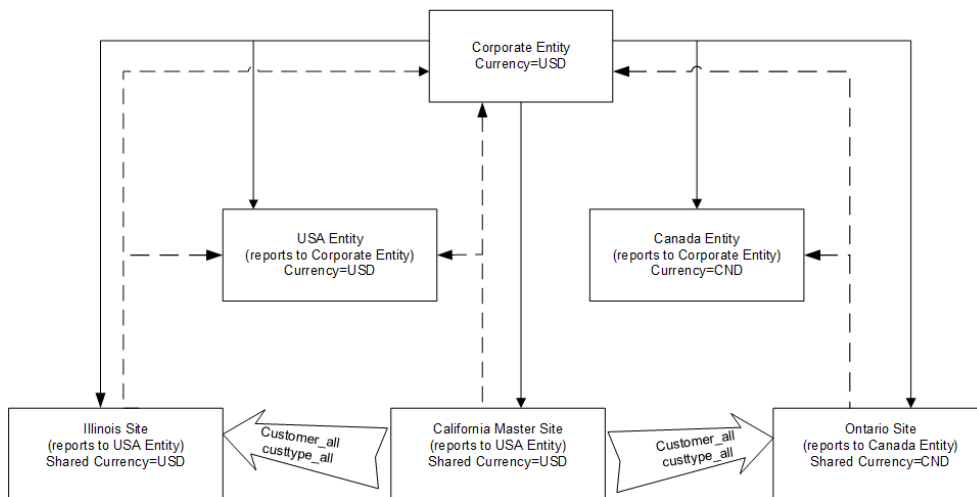

Remember that all of the sites in the same application database must share tables in the same way. You cannot share a table in one site in database A without sharing the table for all sites in database A.

Creating a list of the tables or categories controlled by the master site

For future reference when setting up the Intranet Shared Tables form, create a list of the shared tables (or the replication categories) controlled by each master site.

Updating the SiteEntity spreadsheet

Update the SiteEntity spreadsheet to indicate any sites that are master sites. You could do this either by adding a Master Site column or by adding "Master Site" to the description.

Updating the ReplicationRules spreadsheet

If you plan to add and maintain customers and vendors at your master site, be sure A/P, A/R, Ledger Consolidation (or G/L), and Inventory/Transfer categories are replicating between all sites on the intranet.

All sites on the master site's intranet must be replicating the SiteAdmin category, in order to recognize the master site.

Background information

Use this information to better understand the concepts.

Intranets with shared tables and master sites

On the Intranets form, you can specify a master site for an intranet. Master sites are CloudSuite Business sites that control some data for all other sites on an intranet. For example, master sites control any shared `_all` tables or shared user tables.

An intranet defined as "External" (containing non-CloudSuite Business sites) cannot have a master site defined for it.

You cannot delete an intranet that contains shared tables.

Shared `_all` tables

At the master site, use the Intranet Shared Tables form to choose the `_all` tables that you want to share — that is, the tables that should reside only at the master site for this intranet. Alternatively, you can select a replication category, and the system automatically selects the `_all` tables that are included in that category.

The selected tables are removed from all sites on the intranet except the master site. SQL views to the table on the master site are created at each using, or "slave," site. The other sites can add, update, and delete records through the views.

You can also unshare a shared table from this form. The views at the using sites are dropped, and the `_all` table is rebuilt at each of the using sites on the intranet.

Shared user tables

At the master site, use the Intranet Shared User Tables form to share the user maintenance tables so they reside only at the master site for this intranet.

If multiple sites that belong to the same intranet are not in the same application database, then Intranet Licensing must be set up at the master site and all participating sites before you share user tables for the sites. This requirement is not applicable when all of the sites are in a single database.

The tables are removed from all sites on the intranet except the master site. SQL views to the table on the master site are created at each using or "slave" site. The other sites can add, update, and delete records through the views.

You can also unshare shared tables from this form. The views at the using sites are dropped, and the user tables are rebuilt at each of the using sites on the intranet.

Frequently asked questions about shared tables and master sites

Q: When would I want to set up a master site?

A: We recommend that you set up a master site even if you do not plan to share any tables at this time. (The only exception might be if you have only one or two sites to maintain.)

Master sites currently allow you to centralize entry of customers, items and vendors and to centralize maintenance of licenses and users.

Q: Why would I want to set up shared `_all` tables?

A: If your system is replicating a lot of data among many sites, processing time is reduced when the `_all` tables exist only at the master site.

For example, your system replicates Inventory/Transfer data between 10 sites. A user releases a job that has an "exploding" bill of material, generating thousands of record updates throughout the system. If the inventory-related `_all` tables are stored at each of the 10 sites, system processing speed will be affected during replication of these records to all the sites. If the `_all` tables are stored only at the master site, processing will be much faster.

Q: Why would I want to set up shared user tables?

A: It allows one administrator to maintain one set of users and user permissions in the master site that are applicable to all of the using sites on the intranet. This information is included:

- User information
This can include application-specific data such as user initials, multi-site group, etc.
- Groups information, including user-group assignments, user-group authorizations, and user-license module assignments.

You also have the option to exclude the `AccountAuthorizations_mst`, `UserGroupMap_mst`, and/or `user_local_mst` tables when you share user tables. This allows administrators to maintain users and most user settings in the master site, but apply different permissions for those users in each of the sites. Or you can maintain authorization groups globally (so they are the same for all sites), but maintain the user groups locally, so users can be assigned to different permission groups at different sites within an intranet.

Q: Can I set up some tables to reside only at the master site, and other tables to be replicated at all sites?

A: Yes, for `_all` tables. No, for user tables.

Q: Which tables does it make most sense to maintain at a master site rather than replicating?

A: This depends on your data, and the parts of the system you use the most.

Q: Which tables can only be maintained from a master site?

A: If you are using intranet licensing, the license tables can only be maintained from the master site.

Other than that, you can maintain data at any site (slave or master site).

At the master site, special forms are available for maintaining data about multi-site vendors, customers, and items. You can still maintain this information for specific sites from those sites. But from the master site, you can maintain vendor, customer, and item data for all the sites on the intranet.

Q: Can I have a master site for one intranet and not for another one? If so, why would I want to do that?

A: Yes. The other intranet may not have large `_all` tables, or performance is good. Then for that intranet, there might not be a need for shared `_all` tables. Also note that if an Intranet is flagged as External, then it could not have a master site.

Note: If an intranet is set up to share tables, then only sites for that intranet can be placed in the same application database.

Q: Can I set up a master site any time, or just when setting up the application initially?

A: At any time.

Q: Can I change the master site after it is set up?

A: Yes. Some of the `_all` or user tables at the slave sites have been dropped and would have to be rebuilt, and the data that resides only in the master site's tables would have to be reloaded into the rebuilt tables. You can do this in the Intranet Shared Tables or Intranet Shared User Tables forms.

If you remove a master site, these features that depend on a master site will no longer be available:

- Multi-Site Vendors form
- Multi-Site Customers form
- Multi-Site Items form
- intranet licensing

Q: Can I have a master site on one intranet and no master site on another intranet, and still perform replication between sites on both intranets?

A: Yes.

See the example in the *Mongoose Replication Reference Guide*.

Q: Why would I use a master site if all of my sites are in a single database?

A: The Multi-Site Customers, Multi-Site Items, and Multi-Site Vendors forms can only be used from a master site.

Since all sites are in the same database, most user tables are shared across all sites even without a master site and without setting up Intranet Shared User Tables. However, you can share these user tables only if a master site is defined, through the Intranet Shared User Tables form:

`AccountAuthorizations_mst`, `UserGroupMap_mst`, `user_local_mst`.

Q: Can I add a new site to an existing intranet that has shared tables?

A: Yes. See the online help.

Q: Can I add an existing site that is currently on a non-shared intranet to an intranet that has shared tables?

A: Yes.

Q: Can I change an existing site that is currently on a shared table intranet to be on a different intranet?

A: Yes. You would need to unshare the tables for the site's current intranet, which then rebuilds them at all the sites in the intranet. Then you would move the site to another intranet. And then you would reshare the tables in the old intranet.

Q: What happens to users at the other sites if the master site goes down for an extended period?

A: All sites on the intranet that link to the master site will not be able to access/update the tables that are only on the master site.

Q: Do I still need to set up replication categories and replication rules at each site?

A: Yes, if the sites are in different databases. Even if you select a category to be shared (controlled by the master site), you still may have to replicate that category, because there may also be other tables (not `_all` or user tables) as well as non-table data, such as stored procedures, included in the category.

Although shared tables still appear in the replication category, those tables are not replicated when a rule for that category is set up between sharing sites. Also, if you try to add a shared table to a new replication category, the system will not allow it unless you are in the master site.

Q: Can you change the "Reports To Entity" structure for sites on a shared-table intranet? Can a site that reports to an entity be on a different intranet than the entity?

A: There is nothing to stop it, but this is not a recommended approach.

Q: Will my site see data from all other sites on the intranet when we share a table?

A: If the dropdown list in a form is based on an "`_all`" table, and if you are in a using site where that `_all` table is actually a view, then it will access that view.

If you share user tables, an administrator at any site on the intranet can see and update data for all users and groups, if the administrators have the appropriate permissions. If you originally share user tables and then change to per-site user tables, the user and group information for all users on the intranet is loaded into the tables at each non-master site.

Q: When I upgrade to another service pack or version, will the upgrade utility recognize when a site is using a view and not try to update a non-existing `_all` or user table?

A: Yes, the upgrade process will check for views before trying to add or change columns in an `_all` or user table. However, if you are sharing user tables, you must first unshare the tables, upgrade, and then reshare the user tables. These steps are not required for shared `_all` tables.

Q: If I have existing sites containing the same user names and group names or IDs, what happens when I share the user tables?

A: If the system finds matching user names or group names with different IDs in different sites during the sharing process, it assigns new IDs to the names in the shared user tables at the master site. It also updates the IDs in any non-shared tables that reference the IDs at the non-master sites.

However, the processing assumes that you do not have conflicting user names, for example, the user name "jjones" is unique among all users on all sites on the intranet. If you have existing sites with conflicting user names, for example, "jjones" is James Jones at site OH but Jean Jones at site MI, then you must change one of the user names and all its referenced areas before sharing the user tables.

It is best to share the user tables before sites contain user and group data, if possible. Processing runs much faster with minimal data, and you are less likely to encounter conflicts.

Q: Can I use the master site to copy records from one site to multiple other sites?

A: You can use the Multi-Site Customers, Multi-Site Vendors, and Multi-Site Items forms to copy records to multiple other sites in the same intranet as the master site. The other sites must be in the same multi-site group as the master site. Item BOMs are not copied with item records when you use this method.

Maintaining customer, vendor or item data for other sites in the intranet

Special forms are available only at the master site that allow you to add and maintain some vendor, customer or item data for other sites on that intranet. This section shows examples for vendor data.

Vendor data includes the vendor_mst_all table/view (storing information that is not typically shared among sites), as well as the vendaddr_mst tables (storing information that is shared among all sites). The vendaddr_mst base table is replicated directly from the base table in the source site to the base table in the target site. In a master site scenario, vendor_mst_all is a view at the sharing sites (assuming that vendor_mst_all is set up as a shared table), but vendaddr_mst is an actual table that contains the same data at the master site and all sharing sites.

An example process to add and update vendor data between the master site and sharing sites is shown in this flow chart:

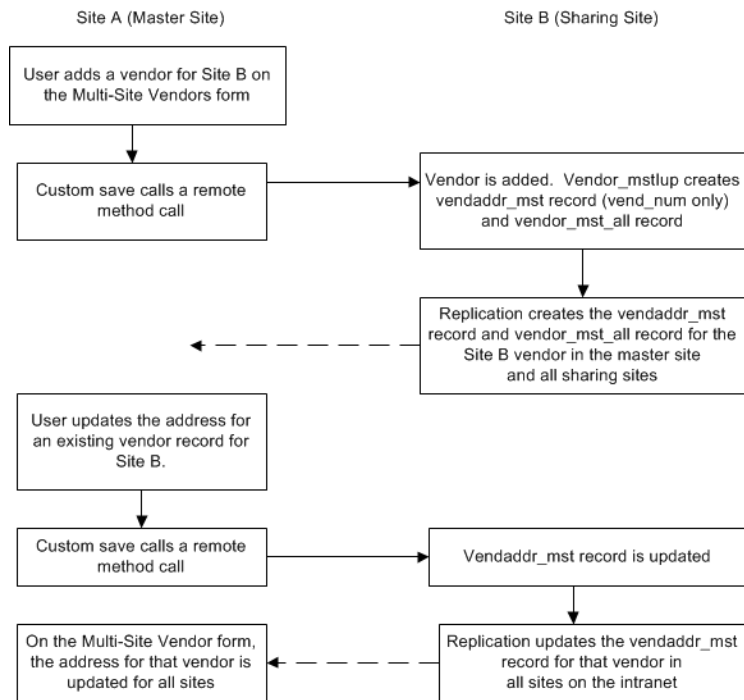

Frequency of data replication

See "Replication overview" on page 137 to get a general understanding about how replication works before you continue. Without that understanding, the replication planning steps probably will not make sense.

Consider this information:

- You can use transactional or non-transactional replication between your sites, or a combination of both.
- Replication rules specify when and where to replicate the categories of data you chose earlier.

Update the ReplicationRules spreadsheet

Indicate which of your rules are transactional or non-transactional. For non-transactional rules, also specify the interval type and timing. For both types, indicate whether all columns should be updated.

1	A	B	C	D	E	F	G	H	I	
2	Source Site	Target Site	Category	Descr	Interval	Type	Interval	Start Interval	Disable Rep	Update All Col
3	CAL	CAN	Site Admin		Transactional		0		0	0
4	CAL	CRP	Ledger Consolidation		Transactional		0		0	0
5	CAL	CRP	Site Admin		Transactional		0		0	0
6	CAL	ILL	A/P		Transactional		0		0	0
7	CAL	ILL	A/R		Transactional		0		0	0
8	CAL	ILL	Centralized Order Entry		Transactional		0		0	0
9	CAL	ILL	Inventory/Transfers		Transactional		0		0	0
10	CAL	ILL	Site Admin		Transactional		0		0	0
11	CAL	ONT	Centralized Order Entry		Transactional		0		0	0
12	CAL	ONT	Inventory/Transfers		Transactional		0		0	0
13	CAL	ONT	Site Admin		Transactional		0		0	0
14	CAL	USA	Ledger Consolidation		Transactional		0		0	0
15	CAL	USA	Site Admin		Transactional		0		0	0

Background information

After administrators have defined the source site, target site, categories, and time frames when replication will occur, they can write their replication rules: "Any time this data changes in this place, replicate it to this place." They then regenerate the replication triggers to enable the replication process.

Replication Rules form

You set up the replication rules in the Replication Rules form at each site. The spreadsheet you create in this step is the basis for the rules you set up. You can copy and paste rows from the spreadsheet into the grid view of this form.

The screenshot shows the 'Replication Rules' window. On the left is a grid with columns for Source Site, Target Site, and Category. On the right is a configuration panel for the selected rule (row 13).

	Source Site	Target Site	Category
1	ILL	CAL	A/P
2	ILL	CAL	A/R
3	ILL	CAL	Centralized Order
4	ILL	CAL	Site Admin
5	ILL	CAN	Site Admin
6	ILL	CRP	Ledger Consolidation
7	ILL	CRP	Site Admin
8	ILL	ONT	Centralized Order
9	ILL	ONT	G/L
10	ILL	ONT	Inventory/Transfer
11	ILL	ONT	Site Admin
12	ILL	USA	Ledger Consolidation
13	ILL	USA	Site Admin

Configuration panel for rule 13:

- Source Site: ILL
- Target Site: USA
- Category: Site Admin
- Description: (empty)
- Interval Type: Immediate
- Interval: 0
- Start Interval At: (empty)
- Disable Replication
- Update All Columns

Interval Type, Interval, and Start Interval At field usage

For each rule, use these three fields together to specify the interval at which replication will occur. For example, you might choose an interval type of **Minutes** and then specify **90** in the **Interval** field. All interval types except transactional are non-transactional, which means that there is no live connection to another site.

These interval types are available:

- **Transactional**: Provides a live constant connection from one site to another. Updates are made to the remote site immediately. No interval or start time is required.
- **Immediate**: Immediately sends the replicated data to the replication queue. This setting does not mean that the data is shown immediately in the other site. It depends on how soon the queue is retrieved by the other site. No interval or start time is required.
- **Minutes**: Replicates data every *nn* minutes, where *nn* is the value specified in the **Start Interval** field.
- **Hours**: Replicates data every *nn* hours, where *nn* is the value specified in the **Start Interval** field.
- **Days**: Replicates data every *nn* hours, where *nn* is the value specified in the **Start Interval** field.

Update All Columns field usage

Specify **Update All Columns** for a rule if you want every table column included in that category or rule to be updated on the target site even if it wasn't changed by a user interaction on the local site. This is not recommended for replication, due to the high data traffic it may generate.

If **Update All Columns** is not specified, replication occurs only for the columns that have been changed.

Rule execution

Replication happens chronologically, based on the order things happened in the source system. For example, an order line cannot be added until after the order is added. So, when looking at the list of tables in a category, the replication process changes data from the listed tables in the proper order - it does not simply run down the list of tables alphabetically to determine what is different.

Use the application event system to set up and maintain workflow or automated events. For a multi-site system, be aware of this information about events:

- Event handling is limited to the site(s) contained in the application database associated with the configuration governing the event object.
- The Dispatch IDO Request event action can initiate IDO activities in another site, if it specifies a URL() that controls activities in another site.
- If an event action effects a database change that normally triggers a replication activity, the replication activity will occur when the event action executes.
- CloudSuite Business Mobile and CloudSuite Business portals require the use of workflow event handlers. If you will be using those features at a site, be sure the Event Service is monitoring that site configuration.

Actions

If you are using multiple utility servers, you can create an Events spreadsheet indicating which servers should monitor which application databases.

If you plan to replicate event metadata between sites in different application databases, you can create the appropriate custom replication categories and rules to handle it.

Background information

In its most basic form, the application event system consists of these interrelated components:

- Events are uniquely named incidents that can be triggered during the use of an application. Events can have multiple triggers and can be fired by user actions, conditions in a database, other events, or other situations.

- Event handlers are software routines and data that determine how the system should respond when the associated event is triggered. Each event can have multiple handlers but each handler can be associated with only one event. Each event handler consists of one or more event actions.
- Event actions are the individual tasks or bits of work that are performed by the event handler. Each event handler can have multiple actions.

For example, suppose you have a sales manager who wants to be notified whenever someone adds a new customer to the system. You could use the application event system to set up an event that fires whenever anyone adds a new customer into the system, and use event handlers and actions to automatically generate a notification that is sent to the sales manager.

Events and event handlers are defined for an application database. If you want an event handler to run only at certain sites in a multi-site application database, use the **Applies To Sites** field to specify the sites.

For more information about how the event components work together, see the *Guide to the Application Event System*.

Monitoring events

Through the Service Configuration Manager on the utility server, you can configure the Event Service to monitor any known configurations from any and all utility servers. Use these guidelines:

- Select an optimal combination for best load balancing.
- It is pointless to monitor a configuration whose application database contains no event handlers or fires no events. However, note that Infor or another vendor from whom you purchased an add-on product might have included event handlers or code that fires events in their distribution, so you should check for these when you consider which configurations to monitor.
- You can create new configurations solely for monitoring by the Event Service.

Each configuration in the monitoring list represents an independent software timer on an independent operating system thread whose time slices can be scheduled (by the operating system) to run on a different CPU than the others, where available.

Example 1

Hardware: One superfast/multiprocessor utility server.

Goal: You want to handle all events on one server.

Implementation: Pick a set of configurations, each of which points to a different application database, and which together span all application databases. Monitor that set.

This table provides the details:

Configuration	App database	Monitor?
ILL_Prod	ILL_App	Yes
ILL_Test	ILL_App	No

Configuration	App database	Monitor?
CAL_Prod	CAL_App	Yes
OH_Prod	OH_App	Yes

Example 2

Data: Six sites (ILL, CAL, OH, COL, CHINA, and FRANCE) and two entities (USA and CRP). The entities will not have events in this example, because they are only used for G/L roll-up.

Hardware: Three utility servers, one of which (Util1) is comfortably loaded with other functions such as replication, TaskMan, or IDO communications.

Goal: Spread the load from the six site application databases over the two free utility servers (Util2 and Util3).

Implementation: Monitor the largest, heavy-traffic site alone or with another lesser site. Monitor the rest together.

This table provides the details:

Server	Configuration	App database	Monitor?
Util2	ILL	ILL_App	Yes
Util2	CAL	CAL_App	Yes
Util3	OH	OH_App	Yes
Util3	COL	COL_App	Yes
Util3	CHINA	CHINA_App	Yes
Util3	FRANCE	FRANCE_App	Yes

Example 3

Data: One heavily used site (ILL_App) with many events firing per second, and/or a need for immediate response to queued and adjourned events.

Hardware: One superfast/quadprocessor utility server (Util1), plus other slower utility servers.

Goal: Select items from the super-site's event queues on as many processors as possible.

Implementation: Monitor the super-site multiple times from the superfast server (once per CPU) and once from the other servers. Monitor the other sites from the other servers, evenly.

This table provides the details:

Server	Configuration	App database	Monitor?
Util1	ILL_1	ILL_App	Yes
Util1	ILL_2	ILL_App	Yes
Util1	ILL_3	ILL_App	Yes

Using the Application Event System

Server	Configuration	App database	Monitor?
Util1	ILL_Prod	ILL_App	Yes
Util2	CAL_Prod	CAL_App	Yes
Util2	OH_Prod	OH_App	Yes
Util2	ILL_Prod	ILL_App	Yes
Util3	ILL_Prod	ILL_App	Yes
Util3	COL_Prod	COL_App	Yes
Util3	CHINA_Prod	CHINA_App	Yes
Util3	FRANCE_Prod	FRANCE_App	Yes

Will you be interfacing CloudSuite Business with a financial product, Analytics, a CRM product, an Infor BOD-enabled application, or a business partner product? If so, how does that affect your multi-site setup?

Some products run against a single CloudSuite Business site. In that case, make sure that all of the CloudSuite Business data that is required for the external product is replicated from other sites to the site that is connected to the external product.

Use the background information to help you determine how, or if, additional products will affect the setup of your multi-site system.

Updating the flowchart and spreadsheets

If you decide to rearrange your sites or rules due to add-on product requirements, update the flowchart and spreadsheets as needed.

Background information

Use this information to help you make multi-site decisions that are related to add-on products and modules.

APS

You can select either the Infor Advanced Planning & Scheduling (APS) or Material Requirements Planning (MRP) for planning your material requirements. There are two planning modes: APS and Infinite APS. In APS mode, you can set resources to have a finite capacity, while Infinite APS mode considers all resources to have infinite capacity. MRP and Infinite APS mode are built into CloudSuite Business. APS mode is a separately licensed CloudSuite Business module.

MRP plans requirements for items according to the level the item appears in a BOM, batching together requirements needed at the same period of time. APS and MRP both generate planned orders, which you firm into actual CloudSuite Business transactions. MRP and APS use the same basic input data. However, the APS system plans all requirements for one demand (through the end item's entire BOM), then plans all requirements for the next demand, and so forth for all the demands, based on order priority and each demand's due date.

APS generates real-time projections of when you can complete orders by comparing all demands against a long-term plan. The system views the current status, including inventory levels, forecasts, job schedules, PO due dates, customer orders, etc. and creates planned orders accordingly to satisfy the demands. You then "firm" the planned orders into purchase orders, purchase requisitions, job orders, production schedules, or transfer orders.

For more information about how APS (or MRP) is used, see the online help. The rest of this section focuses on how APS is used in a multi-site system.

The APS planning algorithm, which produces planning output that is sent back to the CloudSuite Business SQL database, uses a Planner database (PDB) as its in-memory database. Since the PDB is in memory and requires a lot of CPU when it is running, a separate Planning Server is required.

In a multi-site environment, you can generate a global plan for all sites defined in your APS Sites and Alternative Management form. Planned transfer orders are not created when you run planning in a single site.

There are two modes for global planning: Global Planning and Multiple Site Planning, which is defined on the Planning Parameters form, **Advanced APS** tab. In both modes, all sites are planned. The difference lies in how demands for components supplied by remote sites are planned.

With Global Planning mode, these demands are planned by contacting the remote site to get a realistic delivery date. A transfer supply is created at the local site and corresponding transfer demand is created at the supplying site.

With Multiple Site Planning mode, these demands are planned using lead time and planning replication creates the transfer demand at the supplying site.

A global plan generates all plans, transfer supply orders, and transfer demand orders for any remote components using up-to-date planning data at the remote site. To use this option, multiple sites must be defined on the APS Sites and Alternative Management form. The site you are logged into must be configured on the **Main** tab, and the other sites must be configured on the **Remote** tab. If **Global Planning Mode** is set to **Global Planning**, then each site must populate the **Main** and **Remote** tabs of the APS Sites and Alternative Management form. If **Global Planning Mode** is set to **Multiple Site Planning**, then you only need to add remote sites in the site where you will be running Global APS Planning. The sequence in which each site is planned is determined by the site priority defined at the local site where you run APS Planning.

Global Planning steps

When you run APS Global Planning in Global Planning mode, APS performs these steps:

- 1 Connects to all sites that are defined on the APS Sites and Alternative Management form. All sites' PDBs are now locked. No site is able to perform the Get ATP/CTP process or run APS Planning during the time of the global planning process.

- 2 Evaluates the site priorities and begins planning at the site that has the highest priority (the site with the lowest numerical priority value).
- 3 Removes and replans all demands at the site. Transfer orders are planned for any components supplied by a remote site.
- 4 Begins planning the next site in the site priority hierarchy.
- 5 When the system finishes replanning all sites, the global plan is complete and the PDBs are unlocked. At each site, any transactions entered in CloudSuite Business during the planning process while the PDBs were locked are now entered into the plan incrementally.

Multiple site planning steps

When you run APS Global Planning in Multiple Site Planning mode, APS performs these steps:

- 1 Connects to all sites that are defined on the APS Sites and Alternative Management form. All sites' PDBs are now locked. No site is able to perform the Get ATP/CTP process or run APS Planning during the time of the global planning process.
- 2 Evaluates the site priorities and begins planning at the site that has the highest priority (the site with the lowest numerical priority value).
- 3 Removes and replans all demands at the site (in single-site mode). For any component supplied by a remote site, replication is used to transfer that demand to the remote site.
- 4 Begins planning the next site in the site priority hierarchy.
- 5 When the system finishes replanning all sites, any remaining unplanned transfer demands are incrementally planned at each site.
- 6 When the system finishes planning the transfer demands, the global plan is complete and the PDBs are unlocked. At each site, any transactions entered in CloudSuite Business during the planning process while the PDBs were locked are now entered into the plan incrementally.

Transferred items

During global APS Planning, or during any incremental planning activity, if an item requires a component that is supplied by another site (that is, an "inter-site" transfer), transfer orders are planned using these steps:

- 1 Contacts the supply site that produces the remote item (based on the **Supply Site** field on the Items form).
- 2 Plans the item in a test copy of the supply site's PDB (also considering the transit time value defined on the Inter-Site Parameters form).
- 3 Plans the component in the supply site's master PDB and creates a planned transfer demand order.
- 4 Creates a corresponding planned transfer supply order at the site requiring the remote component.

Note: Due dates on planned transfer orders include transit time.

If APS Planning is unable to contact the supply site (due to the site's PDB being down, network problems, etc.), it uses the item's lead time and the transit time defined on the Inter-Site Parameters form to determine the projected availability of any remote components.

Transfer orders can automatically generate additional remote orders, depending on the component's requirements. For example, if site A needs a component that is produced at site B, and the component at site B requires a component produced at site C, APS Planning plans the demand transfer order at site C automatically.

Note: The system does not globally plan intra-site transfers (that is, items where the Supply Site is set to the local site).

After a transfer supply order is generated by a demand order, no other demand order can use inventory created by the transfer supply order. However, any excess inventory generated due to minimum lot sizes remains available at the supply site for other demands to allocate.

APS Planning creates planned transfer orders; you must firm them into actual transfer orders in the Planning Detail form or the Material Planner Workbench form.

In order to transfer items between sites, there must be a replication rule for the Inventory/Transfer category between the sites.

Site recursion in a bill of material

Global Planning mode does not support site-to-site recursion on a single order line. That is, an item at one site cannot require a component from a site that was a supply site higher in the item's bill of material. The Site Recursion limitation applies only to Global Planning, and not to Multiple Site Planning.

For more information about APS, see the online help.

Analytics

Infor Analytics for CloudSuite Business takes the data from your CloudSuite Business databases and turns it into multi-dimensional business information you can use to monitor financial, manufacturing, sales, inventory and purchasing data for your organization. The application includes these components:

- Infor ION BI OLAP Server for multidimensional analysis, planning and modeling
- Infor ION BI Repository to manage users, user groups, permissions and roles
- Infor BI Query & Analysis
- Infor ION BI Application Studio, used for reporting via Web browsers, with output to PDF and Excel.
- Infor ION BI Office Plus, which is an Excel interface for ad-hoc analysis or cell-based reporting.
- Infor ION Dashboards to provide quick views of KPIs relevant to a particular objective or business process.

Use the SysInitialization.xls spreadsheet to specify information for each site that you want BI to connect to:

- Site ID
- Database server
- Database name

When users generate BI reports, they can use the Site dimension to specify the site for which they want to see data, or specify **All** to view a summary of data for all sites. To restrict certain users to access only certain sites, instead of all sites, administrators can define data level permissions on the Site dimension.

Drill-through back to the CloudSuite Business application is not currently available.

For more information about BI setup, see the *Infor CloudSuite Business Analytics Installation* guide.

Country packs and localizations

In the case of CloudSuite Business country packs that are separately installed, the country pack languages and localizations are applied to selected configurations on a utility server. The country pack wizard finds the appropriate application databases, forms databases, and objects databases to update, based on the configurations defined on the utility server.

Country packs are optional, based on what your company has purchased. If a pack is licensed and installed, it applies to all sites in one application database. Use the Optional Modules form to enable or disable the features of a specific country pack at a specific site.

If a country pack is licensed for a database, but disabled for a particular site in that database, ensure that authorizations are set so that users cannot access forms that are part of the optional module.

CPM

The Infor CPM to CloudSuite Business integration is based on specialized CloudSuite Business views created for this purpose. The CPM model is created from the information in the CloudSuite Business views when the model is built. The CloudSuite Business views pull data from certain `_all` tables. The `_all` tables include a "site" column. During the CPM model creation, the CloudSuite Business "site" information is used to create the CPM organization structure. CPM uses this information to roll up values from the sites into a CPM "total unit." If your company structure changes, you may need to update the CPM organization structure from the CloudSuite Business integration views.

CloudSuite Business summary data, rather than transaction detail data, is loaded into CPM. CPM allows users to drill through to a journal transaction detail data view that is provided as part of the Cloud Suite Business integration.

For more information about the CPM 10 integration, see the *Infor CloudSuite Business CPM 10 Integration Guide*.

Credit Card Interface

Using the Credit Card Interface for CloudSuite Business, users can enter and validate credit card information from a centralized customer order entry site, and then charge the card from a different shipping site where the invoice is generated. To use this feature, include the CCI Centralized Order Entry replication category in a replication rule. Then, when a user clicks **Pay with Credit Card** during order entry, if a successful authorization is received, the system replicates that authorization information to each of the sites that are set up to receive this replication category. When an invoice is generated in the shipping site, the system sees the replicated authorization and completes the credit card payment

process. See the *Infor CloudSuite Business Credit Card Interface Configuration Guide* for more information.

DataViews and Critical Numbers

You can build DataViews and Critical Numbers over IDOs that show data from multiple sites. For Critical Numbers, you can write stored procedures that access data from any site. For more information, see the CloudSuite Business online help.

EDI

Electronic Data Interchange (EDI) is a module included with CloudSuite Business. EDI allows trading documents, such as purchase orders, shipment authorizations, advanced shipment notices, and invoices, to be communicated electronically so that they do not have to be re-entered manually. Companies exchange transaction data using data files in an ANSI standard format. CloudSuite Business, which is integrated with an EDI translator, imports inbound transactions from the translator and exports outbound transactions to the translator.

EDI is usually set up to work with one site. You can have multiple sites, each with its own setup and translator but not sharing EDI data. Or you may be able to set up a customized design for sharing EDI information in a multi-site system.

In CloudSuite Business versions previous to 8.0, EDI was a separately licensed module. EDI is now included in the standard product license.

Enterprise Financials (SLSI)

The Infor CloudSuite Business Enterprise Financials interface product provides a specific set of parameters, mappings, and processes that allow certain types of financial data to flow between Cloud Suite Business and SunSystems.

The interface uses non-transactional replication to export CloudSuite Business transactions and data, and uses stored procedures to retrieve certain SunSystems data into CloudSuite Business. You must define a site on an external intranet for the interface, and define a URL pointing to the interface. Additional SUN replication categories are added during implementation.

The interface allows you to map SunSystems business units to CloudSuite Business sites, to review errors and resubmit transactions that failed during transmission to SunSystems, and to notify users by email if a transmission failure occurs.

See the *Infor CloudSuite Business Enterprise Financials Installation Guide* for more information.

Microsoft Excel add-in

With the CloudSuite Business add-in for Microsoft Excel, you can retrieve and format CloudSuite Business general ledger data from sites and entities into an Excel workbook to produce reports such as Balance Sheet, Profit/Loss Statement, and Cash Flow Statement.

You can associate different Excel worksheets in a single workbook with different site databases. For example, you could have one worksheet associated with Site A and another worksheet associated with Site B. You can then have a third "consolidated" worksheet that pulls information from Site A and Site B.

You can specify a site group in the Site parameter of these functions, to consolidate financial data from the sites in the group:

- SLGL
- SLGLBAL
- SLGLYTDBAL

Specifying a home site

As part of the setup for the Excel Add-in, you specify a connection to an CloudSuite Business database server and application (site) database. This site becomes the "home" site for this instance of Excel, and is the default site whenever you open an Excel workbook. The "master" or "home" site is also the source of connection information about other sites within the server.

When a tenant is finished being created, the consumer will receive an email detailing a number of useful URLs. Both the End Point and Web Client URL values are provided.

Specifying a default site for a worksheet

The CloudSuite Business toolbar in Excel includes a Site drop-down list. The list is populated with sites that meet the criteria mentioned below.

To associate different worksheets with different sites, select a site name from the drop-down list in the toolbar. Then right-click on the worksheet tab and select Associate Site(sitename). The worksheet stays associated with that site even when you select a different default site name in the toolbar.

Associating a site with a worksheet is helpful, because the tool bar value then changes automatically when you select each worksheet and make the worksheet active.

Specifying sites in formulas

In individual cells of a worksheet, formulas can specify the site from which the data is pulled. If a site parameter is specified in the formula, the site that is explicitly supplied by the parameter is always used. Any formulas in the worksheet that do not specify a site name assume that the data is pulled from the site specified in the toolbar.

The site value on the toolbar is initially set to the "home" site. The site value in the toolbar changes when a worksheet is activated that has a different site associated with it. You can change the site value in the toolbar to specify a site other than the worksheet's associated site, as long as it meets the criteria listed below.

In most cases, we recommend that you include the site name in all formulas, to provide clarity about which site the data comes from. The exception to this is for dynamic worksheets that you run against different sites.

Note that there is nothing in the extracted data that indicates which site it came from.

Associating sites with a worksheet or using sites in formulas

A workbook can display data from more than one CloudSuite Business site, as long as these criteria are met:

- The site must be on the same database server as the home site.
- The site must be listed on the Sites/Entities form at the home site, and the Application Database field on that form must be filled in for the site.
- The user is authorized to access data on the other sites.

Any sites that meet this criteria are displayed in the drop-down list on the toolbar.

Licensing and permissions

In order to use the IDO Web Service, users must be assigned an Automation license. Also, certain middleware authorizations must be assigned for the user on the Object Authorizations for User form.

For more information about the Excel add-in, see the *Infor CloudSuite Business Microsoft Office Integration User Guide*.

Factory Track

One instance of Infor Time Track integrates with one CloudSuite Business site. This is true when Cloud Suite Business has multiple sites per database, and also when there is one CloudSuite Business site per database. Each Time Track instance must be in its own database. The databases can all be on one database server.

EveryCloudSuite Business site is provisioned with a matching Factory Track tenant. Each Factory Track site is in a separate database (and therefore tenant). Multiple sites per database are not currently supported for Factory Track.

Global Financials (Varial)

The integration of Infor Global Financials with CloudSuite Business supports one or more CloudSuite Business sites mapped to one IGF company. CloudSuite Business and IGF share customer, vendor, and financial account master data. CloudSuite Business invoices and vouchers are transferred to IGF for posting and processing of payments.

BOD-enabled applications (ION)

Infor uses the ION enterprise messaging system to transport data between CloudSuite Business and other Infor BOD-enabled applications. The data exchanged is sent as XML documents referred to as Business Object Documents (BODs). These documents are defined by Open Applications Group Integration Specifications (OAGIS).

In order to integrate with BOD-enabled applications, an accounting entity and a logical ID must be defined for each site within CloudSuite Business, and then a document flow must be set up between the connection point and the other application.

Industry packs

In the case of CloudSuite Business industry packs that are separately installed, the industry pack is applied to selected configurations on a utility server. The wizard finds the appropriate application databases, forms databases, and objects databases to update, based on the configurations defined on the utility server.

Industry packs are optional, based on what your company has purchased. If a pack is licensed and installed, it applies to all sites in one application database. Use the Optional Modules form to enable or disable the features of a specific industry pack at a specific site.

If an industry pack is licensed for a database, but disabled for a particular site in that database, ensure that authorizations are set so that users cannot access forms that are part of the optional module.

Infor Local.ly

CloudSuite Business can interact with Infor Local.ly through BODs or XML documents.

CloudSuite Business sends BODs to Business Vault, and Infor Local.ly accesses the Business Vault data. Business Vault can hold data from multiple sites.

For XML reports, we pass a data set to Infor Local.ly Reporting. Fields on the Intranets form define the location of the Infor Local.ly report renderer. You can specify the same Infor Local.ly URL, shared folder and data set server in the Intranets form at multiple sites.

Mobile

In mobile forms where a user can view data from different sites, a **Site** drop-down list is displayed on the form. If the form's data comes from an `_all` table, no logging in and out of sites is needed. However, in the case of a customer address, the `custaddr_mst` table can be shared among multiple sites. When the table is shared, the **Site** list is populated with sites that are participants in the sharing. When the table is not shared then the list displays only the current site.

If the data must be accessed from separate site databases, then the user must select a configuration from the list and tap the **Switch** link to "switch sites." Behind the scenes, a URL is built that includes the name of the Web server, the new configuration, the current form, and the user's name. A login screen to the other site is displayed. If you want the switch to be seamless, without requiring the user to enter a password, then set up the user with a workstation login in that site.

The use of the Switch Sites feature assumes that all of your sites use the same web client on the same web server.

Office Application Search Service

The search is performed only on the site (configuration) that is specified in the Select a **Config** field during the search service setup in Microsoft Office. However, users can point to a different site by changing the configuration value.

For more information about the Application Search Service, see the *Infor CloudSuite Business Microsoft Office Integration User Guide*.

Outlook

We recommend that users connect to the same site each time they use the CloudSuite Business add-in for Microsoft Outlook. Users can change the setup to point to a different configuration; however, this can cause duplicate contacts in Outlook, because the row pointer of the contact record is different in different CloudSuite Business databases. There are cases where switching sites can be useful; for example, you could copy SiteA contacts into Outlook, and then copy those contacts from Outlook into SiteB.

For more information about the Outlook Add-in, see the *Infor CloudSuite Business Microsoft Office Integration User Guide*.

Configure Price Quote (CPQ)

You can use Infor Configure Price Quote (CPQ, formerly PCM or BuyDesign) with CloudSuite Business to configure products. A site parameter is passed to the Configurator through the configuration Header ID.

Some previous versions of this product required unique order prefixes in each site, in order for configurations to work properly in a multi-site, single database environment. Unique order prefixes are no longer required for CPQ configurations. (However, unique order prefixes are still required in each site in CloudSuite Business if you use centralized order entry features such as shipping lines from remote sites.)

PLM

CloudSuite Business integrates with Infor PLM 8 for adding operations to BOMs generated by PLM. These BOMs are imported as XML files and processed using the BOM Import Builder form. In addition, the XML files can be imported using the BOM Bulk Import utility.

In a multi-site environment, as long as the client machine can access the XML file, the user can load the data.

PLM Accelerate

Multi-site integration to PLM Accelerate is supported. The BODs that are sent between the applications contain accounting entity or site information.

You can define multiple ERP “companies” in PLM Accelerate, Each PLM company has a name and a set of properties, which are equivalent to CloudSuite Business sites, with currency codes and a chart of accounts.

Portals

Customer, Vendor and Reseller Portal Web pages can connect to multiple sites, to display and update data from those sites. Portals have a primary site, where key data such as items and item categories is maintained by CloudSuite Business users. Some data is obtained strictly from the primary site; other data comes from all sites.

These methods of retrieving and maintaining data to or from multiple sites are used:

- Use a multiplex data source, known as a portal site group, to retrieve or save data simultaneously to or from all sites tied to the portal, or to execute a method simultaneously in each site.
- Use RemoteMethodCall to affect or retrieve data to or from multiple sites.
- Use CloudSuite Business _all tables to obtain multi-site data by connecting to a single site.

Define portal data source configurations through the Portal Manager, to include databases for each site in the portal site group:

- One of the data sources must be named **PrimarySite**, which points to the single CloudSuite Business database where all portal-enabled items and item category hierarchies must be defined. Other data must also be maintained in this primary site.
- One of the data sources must be named **PortalSiteGroup**. This data source must include the primary site and all other sites that the portal can access. The PortalSiteGroup is the default data source.
- If there is only one site in the portal site group, both the primary site and portal site group data sources must be defined and must point to the same site.
- If one of the sites to be exposed to the portal is a master site, then the portal site group must be a site group in which the master site is included.

In this case, we recommend that the primary site of the portal be the same as the master site, although this is not required. If you make them the same site, you can use the Multi-Site Items, Multi-Site Customers, and Multi-Site Vendors forms in the master site (primary site) to maintain data across the other sites in the intranet. A master site user can then copy items from the non-master sites to the master site, which is useful because all portal-exposed items must be listed in the primary site's item_mst table.

- If a master site exists, and users are shared through the Intranet Shared User Tables form, then the primary site must be the master site. For more information, see the *Infor CloudSuite Business Licensing Administration Guide*.

In the Site Groups form, define a group that is assigned to the portal. This group is identified as the portal site group in the Portal Parameters form. This group must include all sites that contain information that is displayed in the Customer Portal or Vendor Portal.

Replication rules

All sites in the portal site group must be linked and replicated using standard replication rules. For the Vendor Portal, the A/P and Vendor Portal replication categories must be replicated across all sites in the Vendor Portal site group. For the Customer Portal and Reseller Portal, the A/R, Centralized Order Entry, and Customer Portal replication categories must be replicated across all sites in the Customer Portal site group.

Accounts Receivable

If you plan to use the Customer Portal in a multi-site setup, define the aging bucket in the CloudSuite Business Accounts Receivable Parameters form the same way in all sites included in the Customer Portal site group.

If the Customer Portal site group contains a different set of sites than the Accounts Receivable site group, the customers' account balance data will not equal the balance shown in the CloudSuite Business Accounts Receivable Transactions Summary form, and might not represent the actual aging information.

Customers

If you plan to use the Customer Portal in a multi-site setup, all customer records must use consistent customer numbers across sites, that is, Customer 1 in site A must be the same as Customer 1 in site B.

Interactions

When CloudSuite Business users subscribe to interaction alerts, they must subscribe to the alert in the site where they are responsible. If CloudSuite Business users also want to be notified of interactions created from the portal that do not reference a specific object, they must also subscribe to the alert in the primary site. Portal users who subscribe to an interaction alert are subscribed to that publication in all sites.

The same set of interaction topics must be defined in each site of the Customer Portal site group. Interactions topic translation must be the same across all sites that belong to a portal site group, for Customer Portal, Reseller Portal and Vendor Portal.

Resellers

A customer can be associated with only one reseller across all sites in the portal site group. A customer is either associated with a reseller or is not associated. This must be true across all sites and Ship To records. Salesperson IDs used for reseller association must reference the same vendor number across sites.

Vendors

If you plan to use the Vendor Portal in a multi-site setup, all vendor records must use consistent vendor numbers across sites, that is, Vendor 1 in site A must be the same as Vendor 1 in site B. If a vendor is not defined in any site, then no data for that site is displayed for the logged-in vendor.

Users

The sites from which information is displayed to portal users depend on the type of login, the type of portal, and the specific portal page.

For example, on the portal pricing pages, B2B customers can see pricing for the item at all sites connected to their primary site, but B2C customers and pre-login customers can only see pricing for the item at their default site.

The user account must exist in all the sites of the Portal Site group. If the portals connect to multiple sites and the user account is missing in any of these sites, access is denied on login.

SCE Warehouse Management (WM) module

A CloudSuite Business site can contain one or more SCE WM-controlled warehouses. One instance of SCE can be integrated with a multi-site CloudSuite Business system where customers and items are the same in all sites, or with multiple single-site instances where the customers and items are different in each site.

In WM, clear **Use ExternStorerKey** for trading partners if all trading partner IDs will be unique across the enterprise and trading partner IDs will not exceed 15 characters. If the same ID might be used by different accounting entities, or if trading partner IDs might exceed 15 characters, select this option. After trading partners are loaded into SCE, this option cannot be changed.

Service

Infor CloudSuite Business Service is an optional module with separate licensing. The multi-site setup includes adding rules for replication categories related to the Service module. See "Replicating Service data" on page 94.

Determine which users, and how many users, must work in multiple sites. Determine the types of licenses these users require.

You might already have had some discussions with your sales representatives about licensing. This step refines your existing licensing decisions based on the multi-site planning decisions you have made.

Considerations

Consider these questions:

- How many people need access to only one site?
- How many people need access to multiple sites?
- How many people need access to entities?
- What modules or add-on products require additional licensing per database?
- Will you have custom forms?
- Do you want to control licensing for all sites on an intranet from a master site?
- Will you use demo and/or pilot databases?
- Will you be using Infor Ming.le widgets, the Excel add-in, or other automation sessions to display information from CloudSuite Business IDOs?
- Will your customers be accessing CloudSuite Business data through a portal?
- Will your users be accessing CloudSuite Business from their mobile devices?
- Will your users be accessing CloudSuite Business forms from within Microsoft Outlook?

You must have a license document to apply your licenses. Infor provides this document in the form of a .txt file when you purchase an Infor product. The file contains, in an encrypted format, all the information needed to apply your licenses to each application database. However, you must determine what licenses you need before the license document can be provided.

Creating a License spreadsheet

Review the background information in the *Infor CloudSuite Business Licensing Administration Guide*. Then create a License spreadsheet to list the types and number of licenses you need.

This is an example of the License spreadsheet:

***ALL LICENSES FOR ONE APPLICATION DATABASE MUST BE THE SAME TYPE (Concurrent or Named)							
Site	Use Intranet Licensing?	If Yes, Master Site Name	SQL Server	App Databa:	DB Type	License Module	# Users Type
CRP			MARS	Crp_App	Entity	Entity	4 Concurrent
USA			MARS	USA_App	Entity	Entity	4 Concurrent
CAN			SATURN	Can_App	Entity	Entity	4 Concurrent
ILL			MARS	Ill_App	Site	Transactional_MS	8 Concurrent
ILL			MARS	Ill_App	Site	Transactional	3 Concurrent
ILL			MARS	Ill_App	Site	Automation	3 Concurrent
ILL			MARS	Ill_App	Site	Inquiry	8 Concurrent
ONT			SATURN	Ont_App	Site	Transactional_MS	8 Concurrent
ONT			SATURN	Ont_App	Site	Transactional	3 Concurrent
ONT			SATURN	Ont_App	Site	Inquiry	10 Concurrent
ONT			SATURN	Ont_App	Site	CRM	3 Concurrent

Consult your Sales Representative about any changes to your existing license requirements.

Background information

Review the *Infor CloudSuite Business Licensing Administration Guide* for information about how licenses are used in a multi-site environment. This document explains the licensing of modules in a multi-site environment, how the intranet licensing option works, and which product and module licenses have special multi-site versions.

If you have a large multi-site system, you will have many site IDs, site names, configuration names, intranet names, group names, and database names to manage. Now that you have set up your initial plan, review the flowcharts and spreadsheets for naming consistency.

It is easier to keep track of which site users are currently logged into, if the names you use are logical, and the configuration name matches the application database name, which matches the site name, and so on.

Considerations

Consider this information:

- After a site is created, changing its site ID is time-consuming and requires a complete stoppage of work in all databases that communicate with, or replicate to, that site.
The site ID should remain the same throughout your test, pilot, and production phases, if possible.
- Avoid generic site names (for example, "Site1") that do not differentiate your sites. Use names that describe the location, the hierarchy, or what the site is used for.
- Avoid using these special characters in configuration names and site IDs or site names:
 - \ (back slash)
 - / (forward slash)
 - : (colon)
 - * (asterisk)
 - ? (question mark)
 - " (double quote)
 - ' (single quote)
 - < (left arrow)
 - > (right arrow)
 - | (vertical bar)
 - (embedded space)

- The site ID, the site name, and the application database name should relate to each other, if possible. The site name can be much longer than the ID. For example, if your Site ID is ARIZ, your site name could be Arizona and your application database name could be ARIZ_App.
You might want to include the type (site or entity) information in the site name. If you have multiple sites in one application database, the database name should be more generic but still descriptive.
- See also the information on configuration names on "Configuration names" on page 72.
- In web server names, avoid using special characters other than '-' or '.' A Microsoft security feature does not preserve session state when web server names in URLs contain other special characters. If your web server must use other special characters, use the IP address in URLs pointing to the server.
- For site groups, use names that define their function (for example, FINANCE) or their location (for example, PACIFIC), depending on the logical grouping.
- Do you want to use prefixes to distinguish site-specific customers, vendors, jobs, transfer orders, purchase orders, and so on?

Updating the flowchart and spreadsheets

If you decide to change your naming conventions based on the information in this chapter, update the flowchart and spreadsheets as needed.

Determining prefix use for records in different sites

Determine whether you want to include site-specific prefixes on customer and purchase orders, transfers, and so on.

Background information

Use this information to better understand the concepts.

Prefixes

At each site, you can specify prefixes for these types of records:

- Applicant
- Builder invoices

- Builder purchase orders
- Builder vouchers
- Container
- Co-product mix
- Current job
- Customer
- Customer order
- Customer order contract
- Delivery order/BOL
- Drop Ship number
- EDI order
- EDI order acknowledgement
- Employee
- Estimate
- Estimate job
- Estimate project
- Export document
- Job
- Lot
- Maintenance ID Prefix (on Resources form)
- Office
- PO contract
- Point-of-sale customer order
- Point-of-sale service order
- Position
- Production schedule
- Project
- Purchase order
- Purchase order requisition
- RFQ
- RMA
- Schedule ID
- Serial number
- Transfer order
- Transfer/Project BOL
- Vendor
- Vendor-created PO
- Vendor-created PO requisitions

For example, if you specify **CO** as the prefix for customer orders, the default customer orders created in this site will be CO00000001, CO00000002, CO00000003, and so forth. If you do not enter a value in the **Order Prefix** field, the default customer order numbers used in this site will be 1, 2, 3, and so forth.

A prefix can consist of numeric and non-numeric (letters and symbols) characters. However, the prefix should end with an alphabetic character to ensure that the system increments order numbers correctly.

When you reach the 10-character limit, the system prompts you with a warning message. You must start a new prefix sequence. In the CO example, when you reach CO99999999, you must begin a new customer order prefix.

Using a site indicator in the prefix

For some types of records, you might want to include a site indicator as part of your prefix, to avoid duplication between sites, and to provide a larger pool of transfer order numbers.

For example, you have a site located in Dallas that uses 'TD' as the transfer prefix, and another site in Columbus that uses 'TC' as the transfer prefix. By default, CloudSuite Business then creates transfer order numbers at the Dallas site with a prefix of 'TD', for example TD00000001, TD00000002, TD00000003, etc.

When you create a transfer order in Dallas that will be shipped to the Columbus site, the next default transfer order number for Dallas is used, for example TD0000000321. The system also automatically creates a complementary record in Columbus with the same transfer order number, TD000000321.

The creation of the complementary record provides you with a way to track a transfer order between two sites. In this example, both Dallas and Columbus will recognize 'TD000000321' as the same transfer. Besides avoiding duplication, another benefit of using a meaningful transfer order number prefix is that you can determine which site originated the transfer order.

Be aware that adding a prefix limits the number of digits available for the record number. If you use a long prefix, you will have a smaller pool of numbers available.

Also be aware that prefixes are only used when you allow the system to auto-generate new records.

Lot and serial prefixes

Lots and serial numbers can use "intelligent" prefixes. The prefix can include information such as the date or job number, reference information or a site ID.

For more information about intelligent prefixes, see the online help.

Item numbers

Generally, item numbers are descriptive of your products and are not site-specific. If an item will exist in multiple site databases, you should use the same item number for the same part in every site. This allows you to ship items across sites, perform transfers, and so on.

Now that you have a hierarchical structure of sites, and rules for setting up data flow between them, consider how any radical change to that structure will affect it:

- How will later additions/deletions of sites, or changes to existing sites, affect this structure? Is it set up in a way that will allow changes with the least disruption?
- What if your company buys another company - possibly in a different country? What if your company is acquired? Will this structure be flexible enough to accommodate those changes?
- What if the new company uses a different financial reporting system, or different domestic currency?
- What if one site has to be taken down for maintenance? Will the structure allow your business to continue running during that time?

Revising your flowcharts and spreadsheets

If you decide to rearrange your hierarchical structure or data flows after reviewing the questions in this chapter, then update the flowchart and spreadsheets to match.

Background information

Use this information to better understand the concepts.

Changes to your reporting structure

Over time, sites come and go and the hierarchy of entities may change. As these changes occur, the historical consolidated financial data will not change, and a historical time-phased site/entity structure will be maintained. This allows prior period reporting and drill-downs to yield identical results, even after the structure has changed. On the date of a reporting structure change, a large transaction is posted to close out all accounts for all selected subordinate sites, computing the account balance of

each account. Half of this transaction is immediately consolidated to the existing structure, effectively zeroing the balances from the books. After the hierarchy is changed, the other half of the transaction is consolidated to the new structure, creating opening balances for all the accounts. At the site level, this has no effect, since a debit and credit for the same amount is posted to the same account on the same date.

Be aware of the these rules when changing the reporting hierarchy:

- Financial statement reporting at entities only shows data for transactions that occurred during the time period that the hierarchy was in place.
- When you change an entity's Reports To mapping, there is no historical audit trail of how it was formerly set up.
- Transactions are consolidated to the current structure only, regardless of effective date of the hierarchy change or the ledger transaction date.

Replication overview



The information in this appendix is similar to the first chapter in the *Mongoose Replication Reference* guide, available on our support site. For more details about how replication works, please refer to that guide.

Note: Most of this section is intended for users who have sites in different application databases. If you have all of your sites in one application database, see "Multiple sites in one database" on page 143.

About replication

Data replication is the copying of data between CloudSuite Business sites. The site whose data will be copied is the source, or local, site. The site receiving the copied data is the target, or remote, site.

Replication also allows the system to transmit procedure execution requests (SPs) between the source and target sites.

Infor CloudSuite Business supports two replication methods: transactional and non-transactional.

Transactional replication

This method (also sometimes referred to as "synchronous" or "connected") performs updates on the target site, based on the transaction being performed at the source site. All changes on both the local database and the target database are committed or rolled back together. Transactional replication assumes that the source site and the target site are always connected through SQL Server and have the same database schema (same CloudSuite Business version).

Transactional replication allows immediate updates between databases without the use of queues or XML-formatted content. Only database triggers and direct stored procedure calls are used to replicate the data.

Data errors (for example, requesting an item that does not exist at the specified remote site) are caught immediately, and the system will not allow the user to save the record with the error.

Transactional replication generally should be used between sites on the same intranet. For best performance, both site databases should be on SQL Server machines within the same LAN, or even on the same SQL Server machine.

Non-transactional replication

This method (also sometimes referred to as "asynchronous" or "delayed") assumes that the source site and target site may not be connected through SQL Server. Non-transactional replication uses inbound/outbound queues and XML documents to transfer data or to pass application calls (remote procedure calls, or RPCs).

The sites must be running SQL-based versions of CloudSuite Business.

The sites need not be on the same version of CloudSuite Business; however, if you use different versions, you might need to define XSL transformations so the data arrives at the target site in a usable format for that version. Transformations are required if something significant has changed from one version of the data source to the other, or the target site has more differences than just new nullable columns.

You can also use non-transactional replication to communicate with other applications, if transformations are provided. For more information, see the document *Integrating IDOs with External Applications*.

Non-transactional replication can occur "immediately" (that is, updates are placed in the replication queue as soon as the Replicator service polling interval has elapsed), or at specified intervals (that is, updates are put in the queue when the time interval specified in the replication rule has elapsed). As soon as it reaches the queue, the data is processed by the replication services.

Data errors in non-transactional replication must be handled by the target site system. The user at the source site may not be aware that a replication-related error occurred.

Non-transactional replication populates the ShadowValues table. This and other replication-related tables grow very quickly and may impact system performance.

General notes about replication

You can use transactional replication between some of your sites and non-transactional replication between others; it depends on how the sites are connected and how quickly you want the data to be available.

When data is updated in the target system via replication, the replication process bypasses business rule validation and triggers, so replication should only be performed between "trusted" sites. Referential integrity and database-level constraints still apply. Note also that trigger validation is not applied to tables in any case.

_All tables

The application database can include many tables ending in "_all." In a single-site database, these tables contain data for all sites, while the corresponding base tables contain data only for the local site. The _all tables might include only a subset of the columns from the base table—just enough information to perform local processing on other sites' data.

Example

A system has two sites, OH and MI. OH is replicating its billing terms data to MI, and MI is replicating its billing terms data to OH. The OH_App database has a terms_mst table with these columns and rows:

terms_code	description	due_days	disc_days	disc_pct	prox_day	tax_disc	cash_only	prox_code
2%	2/10 Net 30	30	10	2	0	0	0	99
2%P	2/10 Proxy 30	0	10	2	30	0	0	99
4%	4/10 Net 30	30	10	4	0	0	0	99
4%P	4/10 Proxy 30	0	10	4	30	0	0	99
5%	5/10 Net 30	30	10	5	0	0	0	99

The MI_App site database has a terms_mst table with these columns and rows:

terms_code	description	due_days	disc_days	disc_pct	prox_day	tax_disc	cash_only	prox_code
COD	COD Only	0	0	0	0	0	0	99
N15	Net 15 Days	15	0	0	0	0	0	99
N30	Net 30 Days	30	0	0	0	0	0	99
N45	Net 45 Days	45	0	0	0	0	0	99
NT	No Terms	0	0	0	0	0	0	99
P30	Proxy Day 30	0	0	0	30	0	0	99

Both OH and MI also have a terms_mst_all table with these columns and rows:

Notice that the terms_mst_all table has a site_ref column to distinguish the records for each site. It does not include all the columns from the base table - only the ones that typically would be used in a multi-site environment.

When a billing term is added at OH or MI, the _all tables at both sites are updated.

site_ref	terms_code	description	tax_disc
OH	2%	2/10 Net 30	0
OH	2%P	2/10 Proxy 30	0
OH	4%	4/10 Net 30	0
OH	4%P	4/10 Proxy 30	0
OH	5%	5/10 Net 30	0
MI	COD	COD Only	0
MI	N15	Net 15 Days	0
MI	N30	Net 30 Days	0
MI	N45	Net 45 Days	0

site_ref	terms_code	description	tax_disc
MI	NT	No Terms	0
MI	P30	Proxy Day 30	0

General notes about _All tables

_All tables at the local site are populated with local site data through database triggers when the base table is updated. The _all table may also contain remote site data, populated through replication (depending on the replication rules defined at the remote sites).

_All tables are used when the information in a base table is not typically shared among sites (for example, customer orders or transfers). When the information in a base table is typically shared among all sites (for example, customer addresses), there may be no need for an _all table. Data is replicated directly from the base table in the source site to the base table in the target site. So, such tables usually are replicated directly.

Replication categories and rules

See "Sharing data between sites" on page 77 for descriptions of the default replication categories that are included in this application, with detailed information about each category

These standard categories have been tested to ensure that they include all the necessary database tables, stored procedures, and/or XML documents required to replicate the information used in the specified application function. For example, the A/P category contains the components needed for replicating your Accounts Payable data, the G/L category contains the components needed for replicating General Ledger, and so on. The categories can be included "as-is" in your replication rules.

Using categories with rules

To replicate a category to other sites, create a replication rule for each source-target site combination. For example, if you want to replicate order entry data from site OH to site MI, and you want to use transactional replication, create a rule in the Replication Rules form at the OH site.

Source Site:	OH
Target Site:	MI
Category:	Centralized Order Entry
Description:	
Interval Type:	Transactional
Interval:	0
Start Interval At:	
	<input type="checkbox"/> Disable Replication
	<input type="checkbox"/> Update All Columns

After the rule is defined and saved, click **Regenerate Replication Triggers** on the Replication Management form. This regenerates the table triggers so that the data is replicated according to the specifications in the category and rule.

In certain cases, replication rules and categories determine which sites are available when performing CloudSuite Business functions.

For example, if there is no replication rule set up for Centralized Order Entry from the local site to any other site (or if the rules are disabled), then, when a user accesses the Customer Order Lines form at the local site, the form's **Ship Site** field is disabled and the order must be shipped from the local site. If there is at least one enabled replication rule for Centralized Order Entry, the **Ship Site** field is enabled and lists all available sites. When the user then selects a ship site, the system validates that there is an enabled replication rule for Centralized Order Entry from the local site to the selected remote site. If not, an error message is displayed.

For most other forms that specify a remote site, the system validates a record against the `_all` tables to determine whether the record may be saved. For example, assume you have a transactional replication rule being used to replicate the Inventory/Transfers category between sites. A person creating a transfer order line at the local site selects a remote site from which the item will be transferred, and then tries to save the record. The system checks the `item_mst_all` table to determine whether the selected remote site database contains the specified item. If not, the record validation displays an error.

Point to point replication

Replication is point-to-point between sites. There is no "routing forward."

Consider this example:

- Site A has a rule to Site B that replicates category X (which includes the table xxx).
- Site B has a rule to Site C that replicates category X.
- Site A does not have a replication rule to Site C that replicates category X.

If the xxx table is updated at Site A, the change is replicated to the xxx table at Site B; however, that change is not replicated from Site B to Site C. For an xxx table change at Site A to be replicated at Site C, there must be a replication rule in Site A that sends that data to Site C as well.

Intranets

When you configure a site, you assign it to an intranet on the Sites or Sites/Entities form. Intranets are used to segregate a company's sites into virtual groupings that reflect the actual network setup.

Usually, all the sites on the same LAN and/or database server will belong to the same intranet, and usually sites on different database servers are in different intranets, as shown in this flow chart:

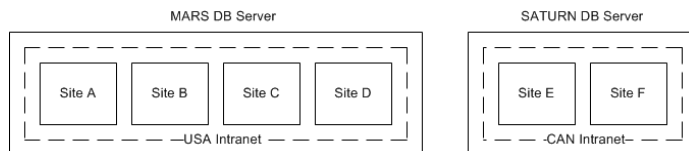

However, it is possible to set up sites on the same database server that are in different intranets, as shown in this flow chart:

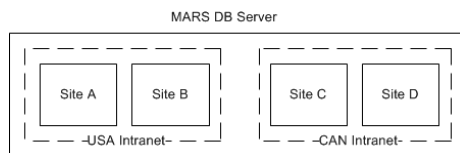

It is also possible to set up one intranet with sites on different servers, as shown in this flow chart:

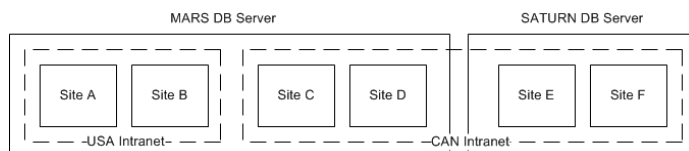

If you have multiple sites in a single application database, and if the sites are sharing `_all` or user tables (through the Intranet Shared Tables or Intranet Shared User Tables utilities), then all sites in that database must be on the same intranet.

Generally, transactional replication should be performed only between sites on the same database server, for performance reasons. However, if your database servers are on a very fast network, transactional replication between sites on different servers is possible.

When a system includes multiple intranets on different servers, the data generally should be transferred between intranets through non-transactional replication (XML documents). When the schema in the source and target databases are not identical—for example, CloudSuite Business to another application that uses Mongoose, or different versions of your application—an XSL transformation (style sheet) should be used. Each intranet has an ASP page that provides intranet access to the inbound queue. The ASP is the gateway to other databases. The address of the ASP is defined on the Intranets form.

Transport protocol

Non-transactional replication between sites on different intranets generally uses HTTP POST (internet) communication. Non-transactional replication between sites on the same intranet does not use HTTP POST; instead, it is handled directly by one utility server and its MSMQ infrastructure.

When CloudSuite Business communicates with other applications using ION, the transport protocol is ESB. The protocol is specified on the Intranets form.

Master sites and shared tables

If your environment has many sites, large amounts of shared data, and many users, you may want to set up one site as the master site for an intranet. Master sites are CloudSuite Business sites that control some data for all other sites on an intranet.

If you use a master site, certain tables can reside only on the master site and are shared (read and written to through a SQL view) by other sites on the same intranet. No replication needs to occur for the shared tables, which can greatly improve system performance and simplify the setting up of replication rules.

After you set up a master site for an intranet and share tables between the sites on the intranet, the intranet is considered a "shared table" intranet. You can add new sites to a shared table intranet. Removing sites from a shared table intranet is more complex, because you must first unshare the shared tables (that is, recreate them) at the site being removed from the intranet. For more information about sharing and unsharing `_all` and user tables, see the online help.

For more information about setting up master sites and shared tables, see the online help and the *Infor CloudSuite Business Multi-Site Implementation Guide*.

Multiple sites in one database

Consider the information in this section when all sites are in a single database.

Replicating `_all` tables

If all sites in your system are in the same application database, the base tables already contain data for each of the sites, so the `_all` tables are not populated and are simply views to the base tables. In that case, replication of `_all` table data is not necessary.

If at least one site is in a separate database, and you are replicating data to/from that site, the `_all` tables are populated.

Replicating base tables

Base tables can include a multi-site column that contains the site name, so that each site in the database can maintain its own records in the table.

You might want to replicate base table data between two sites in the same database. For example, you might want to maintain codes at one site and replicate them to other sites in the database. Whenever a change is made to a code record in the OH site, you want to replicate that change to the MI site. You could set up a replication category that includes the code table, with the Retain Site field cleared. (Clearing the Retain Site field allows the system to create or update a record in the same database table.) Then you create a rule from OH to MI that includes that category.

Replicating shared tables

Shared tables have names that do not end in `_all`, and they do not contain a `site_ref` column. For example, the Event table is shared. If all sites in your system are in the same application database, the data for these tables is shared across all sites; that is, the data is not split out by site. In that case, replication of shared table data is not necessary.

If at least one site is in a separate database, and you want that site to "share" data with the other sites, create appropriate replication rules to and from the site.

Replication category tables

B

This appendix contains brief descriptions of the objects in each of the predefined categories.



Caution: Except where specifically noted, these tables and methods are often used by multiple forms and processes, so removing them from a category might have unintended consequences.

A/P category

A/P object name	Used for
apdrafft_mst_all	A/P draft transactions
apparms_mst_all	Accounts payable parameters - used in A/P payment distribution and generation
ApSitPmtpSp	A/P check/draft/wire/EFT posting
aptrxp_mst_all	A/P posted transactions - used in many A/P areas
bank_addr_mst_all	Bank addresses
bank_hdr_bank_file_fmt_all	Bank code and bank file format cross-references
bank_hdr_mst_all	Bank reconciliation header information
chart_mst_all	Chart of accounts - used throughout the system
chart_unitcd1_mst_all	Unit codes - chart of accounts
chart_unitcd2_mst_all	Unit codes - chart of accounts
chart_unitcd3_mst_all	Unit codes - chart of accounts
chart_unitcd4_mst_all	Unit codes - chart of accounts
commdue_mst_all	Commissions due - used in A/P payment generation/distribution
country_mst	Country codes - used throughout the system
curr_uk_mst_all	Customs and excise exchange rates

Replication category tables

A/P object name	Used for
curracct_mst_all	Default currency accounts - used in currency codes, A/P and A/R payment, distribution, and quick payments
currate_mst_all	Currency rates - used throughout the system
currency_mst_all	Currency codes - used throughout the system
currparms_mst_all	General currency parameters
DelVendaddrSp	Vendor addresses
euro_parms_mst_all	Euro parameters - used throughout the system
item_mst_all	Items - used throughout the system
journal_mst_all	Only used by the Journal Transaction Report. If you do not need to see Journal records from another site, this is not needed.
parms_mst_all	General parameters - used throughout the system
periods_mst_all	Accounting periods - used in many financial areas
poparms_mst_all	Purchase order parameters
RemoteSaveAprxpSp	A/P Posted Transaction Detail
RemoteSitpmt2Sp	Update information in the To site for A/P payment posting. This involves setting the Active flag on the AP Posted Transaction (if it is not already set), creating a journal (debit) entry to Accounts Payable - Liability, creating a journal (credit) entry to Purchase Expense - Discount, creating a journal entry to Inter-Site Liability, updating the vendor's discount YTD, and creating an A/P Posted transaction.
slsman_mst_all	Salespersons - used in A/P payment generation and in the Order Verification Report
tax_system_mst_all	Tax systems - used in A/P payment generation and A/P check/draft/wire/EFT printing/posting
taxcode_mst_all	Tax codes - used in A/P payment generation and A/P check/draft/wire/EFT printing/posting
taxparms_mst_all	Tax parameters - used in A/P check/draft printing/posting
terms_mst_all	Billing terms - used in accounts payable aging
THAApSitPmtSp	Thailand localization
unitcd1_mst_all	Unit codes
unitcd2_mst_all	Unit codes
unitcd3_mst_all	Unit codes
unitcd4_mst_all	Unit codes
vch_hdr_mst_all	Voucher register - used in A/P payment generation

A/P object name	Used for
vch_item_mst_all	Voucher line item - used in voucher listing
vendaddr_mst	Vendor address - used throughout the system
vendcat_mst_all	Vendor categories
vendor_mst_all	Vendor information - used throughout the system
VendorInsUpdSp	Insert/update vendors

A/R category

A/R object name	Used for
ar_terms_due_mst_all	A/R multiple due date payment terms
ARActiveSp	Setting Active flag for A/R transactions
arparms_mst_all	Accounts receivable parameters
ARPaymentDistPostingSp	A/R payment distribution posting
ARPayPostRemoteCopyNotesSp	A/R payment posting - copy notes
ArpmtpblSp	Validate customer number during A/R payment posting
ArSitpmt2Sp	Find invoice information from a specified site and apply an open credit/payment to an invoice during quick payment
artran_mst_all	Accounts receivable transactions
ArtranUpdSp	When information is updated on the A/R Posted Transaction Detail form, this is called to update the information on the referenced site.
chart_mst_all	Chart of accounts - used throughout the system
chart_unitcd1_mst_all	Unit code - chart of accounts
chart_unitcd2_mst_all	Unit code - chart of accounts
chart_unitcd3_mst_all	Unit code - chart of accounts
chart_unitcd4_mst_all	Unit code - chart of accounts
coparms_mst_all	Customer order parameters (includes invoice length, used in many A/R functions)
country_mst_all	Country codes - used throughout the system
CreateArInvSp	Create an (unposted) A/R invoice using information passed to it from ReturnedChecksSp.

Replication category tables

A/R object name	Used for
curr_uk_mst_all	Customs and excise exchange rates
curracct_mst_all	Default currency accounts - used in Currency Codes, A/P and A/R payment, distribution, and quick payments
currate_mst_all	Currency rates - used throughout the system
currency_mst_all	Currency codes - used throughout the system
currparms_mst_all	General currency parameters
cust_lcr_mst_all	Customer letters of credit
custaddr_mst	Customer address
custdrft_mst_all	Customer draft
customer_mst_all	Customers information
custtype_mst_all	Customer types
DeleteRemoteNotesSp	Delete notes tied to a record at a remote site
endtype_mst_all	End user types
euro_parms_mst_all	Euro parameters - used throughout the system
inv_category_mst_all	Invoice category
inv_hdr_mst_all	Invoice header
inv_item_mst_all	Invoice line item
inv_stax_mst_all	Invoice sales tax
item_mst_all	Items - used throughout the system
LoadReplicatedNotesSp	Take a row out of the NotesContentShadow table and updates the matching system, user, or specific note. If the note does not exist, it is created.
MakeRemoteObjectNotesSp	Create an ObjectNotes record at the remote site. It assumes the system, user, or specific notes records have already been created.
MXVATARMultiSiteTransDirSp	Mexican localization
NotesContentShadow	System, user, or specific note information used to populate the appropriate notes record at the remote site.
parms_mst_all	General parameters - used throughout the system
periods_mst_all	Accounting periods - used in many financial areas
RebalCuSp	Rebalance customer balances
RemoteSetArtranCorpCustSp	Corporate customer for A/R transactions
sales_team_mst_all	Sales team

A/R object name	Used for
territory_mst_all	Sales territory
TransferNotesToSiteSp	Allow all the notes for a particular row of a table to be copied to a remote site.
unitcd1_mst_all	Unit code
unitcd2_mst_all	Unit code
unitcd3_mst_all	Unit code
unitcd4_mst_all	Unit code
UpdObalSp	Update customer order balance
UpdPbalSp	Update posted balance

CCI Centralized Order Entry category

CCI object name	Used for
cci_parms_mst	Credit Card Interface parameters
CCICentralOrderEntryReplicateSp	Credit Card order entry information

Centralized Order Entry category

COE object name	Used for
arparms_mst_all	Accounts receivable parameters
cfg_attr_mst_all	Attributes in a configuration
cfg_comp_mst_all	Components in a configuration
cfg_main_mst_all	Configuration description
cfg_ref_mst_all	Configuration reference type information
CfgCheckRemoteXref	Used in processing configured order lines that are shipping from a different site than the order site.
CfgClearRemoteXref	Used in processing configured order lines that are shipping from a different site than the order site.
CfgCreateItemSp	Used in processing configured order lines that are shipping from a different site than the order site.

Replication category tables

COE object name	Used for
CfgRepRemoteConfig	Used in processing configured order lines that are shipping from a different site than the order site.
CfgRepRemoteItemSp	Used in processing configured order lines to set the item and configuration in the order site.
chart_mst_all	Chart of accounts - used throughout the system
ChgRemoteCoitemSp	Change the status in the shipping site (if not currently in the shipping site)
citemh_mst_all	History customer order line/release
co_bln_mst_all	Blanket orders
co_mst_all	Customer orders
co_ship_approval_log_mst_all	Customer order shipment approval
co_ship_mst_all	Customer order shipments
CoChangeToHistSp	Change customer order status
coh_mst_all	History customer orders
CohShipSiteDelSp	Delete customer order history at shipping site
coitem_log_mst_all	Only used by the Item Product Code Cost Detail Sales Analysis Report.
coitem_mst_all	Customer order lines
CoitemSp	Replicate CO line (multi-site)
CoLineRelWarehouseChangeRemote1Sp	Change the warehouse on the customer order line in the shipping site
CoLineRelWarehouseChangeRemote2Sp	Change the warehouse on the customer order line in the originating site
coparms_mst_all	Order entry parameters
CopyNotesFromOrigSiteSp	Copy notes from original site
country_mst	Countries (local site)
country_mst_all	Countries (includes remote sites)
CpSoCpSoCb2Sp	Recopy columns back to the originating site when updated on the ship-site for blanket lines
CpSoCpSoCbSp	Copy a blanket line to the ship-site and perform secondary posting
CpSoCpSoCi2Sp	Recopy columns back to the originating site when updated on the ship-site for regular lines.
CpSoCpSoCiSp	Copy a customer order line to the ship-site and perform secondary posting

COE object name	Used for
CpSoCpSoDbSp	Delete a blanket line to be replaced due to copying
CpSoCpSoDiSp	Delete a customer order line to be replaced due to copying
CpSoCpSoDoSp	Delete a ship-site customer order that no longer has any lines
CpSoCpSoSoSp	Sum the order balance at the ship-site for setting the customer order balance
CrtLogSp	Create a customer order line Change Log record for each blanket release of a blanket line
curr_uk_mst_all	Customs and excise exchange rates
CurrAcctSp	Create a curracct row in the remote site for the currency row just added in the local site. (The record is created but account information is not replicated.)
currate_mst_all	Currency rates - used throughout the system
currency_mst	Currency codes
currency_mst_all	Currency codes (includes remote sites)
currparms_mst_all	General currency parameters
cust_lcr_mst_all	Customer letters of credit
custaddr_mst	Customer addresses
customer_mst_all	Customers
DelCoBlnSp	Delete specified blanket order line
DeleteCoitemSp	Delete specified customer order line
DeleteCoSp	Delete the customer order from remote (ship) sites
DeleteRemoteNotesSp	Delete notes tied to a record at a remote site
euro_parms_mst_all	Euro parameters - used throughout the system
featqty_mst_all	Feature option adjustment. Used only with the product (features-and-options) configurator.
featrank_mst_all	Feature rank
feature_mst_all	Feature group. Used only with the product (features-and-options) configurator.
inv_hdr_mst_all	Invoice header
inv_item_mst_all	Invoice line item
inv_stax_mst_all	Invoice sales tax
InvAdjCSp	When posting an invoice adjustment, this stored procedure updates the discount and price on the customer order line (potentially cross-site)

Replication category tables

COE object name	Used for
item_glbl	Global Items
item_mst_all	Items - used throughout the system
ItemCreateFromFeatStrSp	Create item from feature string
itemcust_mst_all	Customer/item cross reference
itemcustprice_mst_all	Historical customer item pricing
ItemGlblAddDelSp	Add or delete a global item
itemloc_mst_all	Item stockroom location
ItemlogSp	Create a coitem-log record.
itemprice_mst_all	Item price
itemwhse_mst_all	Item warehouse
job_mst_all	Jobs
LoadReplicatedNotesSp	Take a row out of the NotesContentShadow table and updates the matching system, user, or specific note. If the note does not exist, it is created.
location_mst_all	Location codes
lot_mst_all	Lots - used throughout the system
MakeRemoteObjectNotesSp	Create an ObjectNotes record at the remote site. It assumes the system, user, or specific notes records have already been created.
NotesContentShadow	System, user, or specific note information used to populate the appropriate notes record at the remote site.
parms_mst_all	General parameters - used throughout the system
periods_mst_all	Accounting periods - used in many financial areas
pricecode_mst_all	Price codes
priceformula_mst_all	Price formulas
pricematrix_mst_all	Price matrix
proj_inv_item_mst_all	Project bill of lading line item
RebalCuSp	Rebalance customer balances
RemoteCoHld4Sp	As part of the process to take orders off of credit hold, this stored procedure changes the credit hold information for each customer order in the range and then calls RemoteCoHld5Sp.
RemoteCoHld5Sp	As part of the process to take orders off of credit hold, this stored procedure changes the information in the shipping site.
RemoteOrderCreditHoldSp	Put orders on credit hold in each site listed in the site group.

COE object name	Used for
RemoteSetArtranCorpCustSp	Corporate customers in A/R transactions
RepApsCoitemSp	Called after the planner completes to replicate CO Line projected dates to the originating sites
RepCoBlInSp	Replicate blanket order.
RepCoCreditHoldSp	Replicate credit hold information.
RepCoitemSp	Replicate customer order line (multi-site).
RepCoSp	Replicate customer order (multi-site).
RepCustomerBillToSp	Replicate information for the Bill-To customer (customer sequence = 0). This is called when replicating a customer order to conditionally create the customer record.
RepCustomerShipToSp	Replicate information for the Ship-To customer (customer sequence > 0). This is called when replicating a customer order to conditionally create the customer record.
slsman_mst_all	Salespersons
SumCoSp	Recalculate taxes on a customer order and assign the total price
tax_item_jur_mst_all	Item tax code
tax_jur_mst_all	Tax jurisdiction
transfer_mst_all	Transfer orders
TransferNotesToSiteSp	Allow all the notes for a particular row of a table to be copied to a remote site.
u_m_conv_mst_all	Units of measure
u_m_mst_all	Unit of measure conversions
UpdObalSp	Update customer order balance

Customer Portal category

Customer Portal object name	Used for
item_portal_price_mst_all	Prices on portal items
ItemPortalPriceStatusChangeSp	Status change on portal item prices
PortalAccountCreateOrCopySp	Creating or copying portal user accounts
PortalOrderOnHoldCheckSp	Check if order is on hold

Dimensions category

Dimensions object name	Used for
CLM_DimCatTableSp	Dimensions
CLM_DimensionBindingSp	Dimensions
CLM_DimSubCollectionSp	Dimensions
CLM_DimTable2Sp	Dimensions
dim_attribute	Dimension attributes
dim_base_unit	Dimension base units
dim_function	Dimension functions
dim_object_attribute	Dimension object attributes
dim_object_table_join	Dimension table joins
dim_unit	Dimension units
dim_unit_prefix	Dimension unit prefixes
dimension	Dimensions
dimension_object	Dimension objects
GetPeriod	Accounting period
List_DimCatTableSp	Dimensions
LoadValueResSp	

ESB category

This category contains stored procedure names used to clear the site's ReplQListener BOD definition cache and PARMS cache and to trigger each BOD. The stored procedure names do not map to actual stored procedures and are used purely as a triggering mechanism in the ReplQListener service. For more information about how this works, see the online help topic "Behind the Scenes: How the System Generates a BOD."

For information about the user events that trigger each BOD, see the appropriate integration guide or the **Documentation** tab on the Replication Document Outbound Cross-References form.

EXTFIN category

EXTFIN object name	Used for
ExtFinAnaLedgerPosting	Export data from the CloudSuite Business ana_ledger table.
ExtFinAPVoucherPosting	Export data from the CloudSuite Business export_aptrx and export_aptrxd tables, which are holding tables for data collected from various A/P tables.
ExtFinARInvoicePosting	Export data from the CloudSuite Business export_arinv and export_arinvd tables, which are holding tables for data collected from various A/R tables.
ExtFinLedgerPosting	Export data from the CloudSuite Business ledger table.
ExtFinRequestBankHdr	Export a request to the external financial application for updates to the CloudSuite Business bank_hdr table.
ExtFinRequestChart	Export a request to the external financial application for updates to the CloudSuite Business chart table.
ExtFinRequestCountry	Export a request to the external financial application for updates to the CloudSuite Business country table.
ExtFinRequestCurrate	Export a request to the external financial application for updates to the CloudSuite Business currate table.
ExtFinRequestCurrency	Export a request to the external financial application for updates to the CloudSuite Business currency table.
ExtFinRequestCustomerPostedBalance	Export a request to the external financial application for a customer's posted balance.
ExtFinRequestDept	Export a request to the external financial application for updates to the CloudSuite Business dept table.
ExtFinRequestLanguageIDs	Export a request to the external financial application for updates to the CloudSuite Business LanguageIDs table.
ExtFinRequestPeriods	Export a request to the external financial application for updates to the CloudSuite Business periods table.
ExtFinRequestTaxcode	Export a request to the external financial application for updates to the CloudSuite Business taxcode table.
ExtFinRequestTerms	Export a request to the external financial application for updates to the CloudSuite Business terms table.
ExtFinRequestUnitCd1	Export a request to the external financial application for updates to the CloudSuite Business unitcd1 table.
ExtFinRequestUnitCd2	Export a request to the external financial application for updates to the CloudSuite Business unitcd2 table.

EXTFIN object name	Used for
ExtFinRequestUnitCd3	Export a request to the external financial application for updates to the CloudSuite Business unitcd3 table.
ExtFinRequestUnitCd4	Export a request to the external financial application for updates to the CloudSuite Business unitcd4 table.

EXTFIN Customer category

EXTFIN Customer object name	Used for
custaddr_mst	Export CloudSuite Business custaddr information to an external financial application.
customer_mst	Export CloudSuite Business customer information to an external financial application.

EXTFIN Vendor category

EXTFIN Vendor object name	Used for
vendaddr_mst	Export CloudSuite Business vendaddr information to an external financial application.
vendor_mst	Export CloudSuite Business vendor information to an external financial application.

G/L category

G/L object name	Used for
ana_ledger_mst_all	Analytical ledger transactions
ana_pertot_mst_all	Analytical ledger period total
ChangeReportsToCopyChartSp	Changes for reporting to different entity
ChangeReportsToCopyPeriodSp	Changes for reporting to different entity
ChangeReportsToCSp	Changes for reporting to different entity

G/L object name	Used for
ChangeReportsToDelPeriodsSp	Changes for reporting to different entity
ChangeReportsToPSP	Changes for reporting to different entity
ChangeReportsToSetCurrCodeSp	Changes for reporting to different entity
ChangeReportsToZSp	Changes for reporting to different entity
chart_bp_mst_all	Budget and plans
chart_mst_all	Chart of accounts - used throughout the system
chart_unitcd1_mst_all	Unit code 1 information on chart of accounts
chart_unitcd2_mst_all	Unit code 2 information on chart of accounts
chart_unitcd3_mst_all	Unit code 3 information on chart of accounts
chart_unitcd4_mst_all	Unit code 4 information on chart of accounts
ChartAcctRemoteSp	Replicate changes to chart of accounts to remote sites
curr_uk_mst_all	Customs and excise exchange rates
currate_mst_all	Currency rates - used throughout the system
currency_mst_all	Currency codes (local) - used throughout the system
curparms_mst_all	General currency parameters
DeleteRemoteNotesSp	Delete notes tied to a record at a remote site
euro_parms_mst_all	Euro parameters - used throughout the system
ExecuteSQLSp	
FinRptLinRmtSiteTransSp	Transfer line to remote site
FinRptXMLBufCopySp	Called from Financial Report Line Copy to create the complete Financial Statement in the destination site.
GLBudgetCommitSp	Commits budget by moving tmp_chart_bp_entity to chart_bp; adds unit codes if they don't exist.
GLBudgetConsChartBpUpdateSp	Used in budget consolidation
GIBudgetDelChartbpSp	Delete hierarchy from chart_bp
glrptl_mst_all	G/L report line
journal_mst_all	Only used by the Journal Transaction Report. If you do not need to see Journal records from another site, this is not needed.
ledger_mst_all	Ledger transactions
LedgerConsolCommitSp	Add new transaction records into the entity ledger (for ledger consolidation). Also insert records into unitcd{1-4} tables based upon unit codes within ledger rows that are consolidated.

Replication category tables

G/L object name	Used for
LedgerConsolConsolCtaSp	Update the CTA account (for ledger consolidation)
LedgerConsolCtaAdjSp	Adjust the CTA amount (for ledger consolidation)
LedgerConsolLedgerSp	Intermediate step in ledger consolidation
LoadReplicatedNotesSp	Take a row out of the NotesContentShadow table and updates the matching system, user, or specific note. If the note does not exist, it is created.
MakeRemoteObjectNotesSp	Create an ObjectNotes record at the remote site. It assumes the system, user, or specific notes records have already been created.
NotesContentShadow	System, user, or specific note information used to populate the appropriate notes record at the remote site.
parms_mst_all	General parameters - used throughout the system
per_sort_mst_all	Period total sort method
per_unit_mst_all	Unit code combination
periods_mst_all	Accounting periods - used in many financial areas
PeriodsRemoteDeleteSp	Delete accounting periods for a fiscal year
PeriodsRemoteSaveSp	Add or update accounting periods for a site
pertot_mst_all	Period total
RepChartSp	Multi-site chart copy
site_hierarchy	Site hierarchy
tmp_fin_rpt_hdr_c_xml	Financial report line copy/update
tmp_fin_rpt_hdr_xml	Financial report line copy/update
tmp_fin_rpt_lin_c_xml	Financial report line copy/update
tmp_fin_rpt_lin_s_xml	Financial report line copy/update
tmp_fin_rpt_lin_xml	Financial report line copy/update
TransferNotesToSiteSp	Allow all the notes for a particular row of a table to be copied to a remote site.
unitcd1_mst_all	Unit Code 1
unitcd2_mst_all	Unit Code 2
unitcd3_mst_all	Unit Code 3
unitcd4_mst_all	Unit Code 4

Initialize _All Parameters category

Initialize _All Parameters object name	Used for
apparms_mst_all	Accounts payable parameters
aps_parm_mst_all	APS parameters
arparms_mst_all	Accounts receivable parameters
coparms_mst_all	Customer order parameters
currency_mst_all	Currency parameters
currparms_mst_all	Currency parameters
dcparm_mst_all	Data collection parameters
euro_parms_mst_all	European community parameters
invparms_mst_all	Inventory parameters
mrp_parm_mst_all	MRP parameters
parms_mst_all	General parameters
per_sort_mst_all	Accounting period parameters
poparms_mst_all	Purchasing parameters
tax_system_mst_all	Tax parameters
taxparms_mst_all	Tax parameters

Inventory/Transfers category

Inv/Transfer object name	Used for
chart_mst_all	Chart of accounts - used throughout the system
chart_unitcd1_mst_all	Unit code 1 information on chart of accounts
chart_unitcd2_mst_all	Unit code 2 information on chart of accounts
chart_unitcd3_mst_all	Unit code 3 information on chart of accounts
chart_unitcd4_mst_all	Unit code 4 information on chart of accounts
ChkSnSp	Validate serial numbers (matching item/has an available status)
CLM_TransferOrderShpRcvSp	Transfer order ship/receive
country_mst_all	Countries

Replication category tables

Inv/Transfer object name	Used for
CpTSp	Copy transfer orders and lines
curr_uk_mst_all	Customs and excise exchange rates
currate_mst_all	Currency rates - used throughout the system
currency_mst_all	Currency codes (local) - used throughout the system
currparms_mst_all	General currency parameters
dcparm_mst_all	Data Collection parameters
del_term_mst_all	Delivery Terms
DeleteRemoteNotesSp	Delete notes tied to a record at a remote site
euro_parms_mst_all	Euro parameters - used throughout the system
featqty_mst_all	Feature option adjustment. Used only with the product (features-and-options) configurator.
feature_mst_all	Feature group. Used only with the product (features-and-options) configurator.
GetTransferToSiteRecordDateSp	Record date for transfer to site
laPostSp	Issues material and adjusts quantity-on-hand at a warehouse, location, and lot.
InsertOverrideForItemLotAttrSp	Item lot attributes
InsertOverrideForItemPiecesSp	Item pieces
intranet	Intranets
invparms_mst_all	Inventory parameters
item_glbl	Global Items
item_manufacturer_item_mst_all	Cross-reference of CloudSuite Business item to manufacturer item
item_mst_all	Items - used throughout the system
ItemGlblAddDelSp	Add or delete a global item
itemloc_mst_all	Item stockroom location
ItemLocAddRemoteSp	Performs either a local or a remote call for the ItemLocAddSp routine (which creates itemloc records)
itemprice_mst_all	Item price
itemwhse_mst_all	Item warehouse
jobmatl_mst_all	Used only with the product (features-and-options) configurator.
jobroute_mst_all	Used only with the product (features-and-options) configurator.
LcrcptSp	Create a Landed Cost receipt record.

Inv/Transfer object name	Used for
LoadReplicatedNotesSp	Replicated notes
location_mst_all	Location codes
lot_loc_mst_all	Item Lot Location - used throughout the system
lot_mst_all	Lots - used throughout the system
LotAddRemoteSp	Called at a remote site from the local site's LotAddSp routine when the lot being added goes to a remote site.
MakeRemoteObjectNotesSp	Object notes
manufacturer_item_mst_all	Manufacturer items
manufacturer_mst_all	Manufacturers of items
matltrack_mst_all	Lot and serial number tracking
mcal_mst_all	Manufacturing days
MsmptSp	Process transfer orders in multi-site move posting
NotesContentShadow	Notes
parms_mst_all	General parameters - used throughout the system
periods_mst_all	Accounting periods - used in many financial areas
pricecode_mst_all	Price codes
priceformula_mst_all	Price formulas
pricematrix_mst_all	Price matrix
prodcode_mst_all	Product codes
qualify_mst_all	Feature qualifying string
RemoteLoadTmpSerSp	Copy the tmp_ser serial number information to a remote site.
RepAPSTrnItemSp	Replicate APS item
rsvd_inv_mst_all	Reservation - used in many areas of the system
serial_mst_all	Serial numbers - used in many areas of the system
shipcode_mst_all	Ship codes
site	Sites/entities - used throughout the system
system_type	System types
trans_nature_2_mst_all	Nature of transaction codes
trans_nature_mst_all	Secondary nature of transaction codes
TransCpSp	Copy Transfer Order record changes to a remote site. If the sites have different base currencies, the freight, duty, insurance,

Replication category tables

Inv/Transfer object name	Used for
	local freight and brokerage amounts are converted to the other site's currency during the copy process.
TransDeleteSp	Delete a transfer order.
transfer_mst_all	Transfer orders
TransferNotesToSiteSp	Include transfer order notes
TransferOrderShipSp	Transfer order ship
TritemDeleteSp	Delete a transfer order line item.
TritmCpSp	Copy Transfer Order item record changes to a remote site. If the sites have different base currencies, the costs and price are converted to the "other" site's currency during the copy process.
TrnSsdSp	Copy Transfer Order SSD information to a remote site.
Trpurge1Sp	Delete Transfer Orders and related records from remote sites
u_m_conv_mst_all	Unit of measure conversion
u_m_mst_all	Unit of measure codes (all sites)
unitcd1_mst_all	Unit Code 1
unitcd2_mst_all	Unit Code 2
unitcd3_mst_all	Unit Code 3
unitcd4_mst_all	Unit Code 4
UpdateOverrideForItemPiecesSp	Item pieces
UpdateTransferExchRateSp	Update transfer order exchange rate
UpdWhseSp	Update warehouse information - used in Combine Transfer Order Ship/Receive
whse_mst_all	Warehouses

Invoice Builder category

Invoice Builder object name	Used for
arinv_mst_all	Invoices
artran_mst_all	A/R transactions
AU_InvPostingSp	Automotive Industry Pack posting
BGTaskSubmitSp	Submit background task

Invoice Builder object name	Used for
coparms_mst_all	Customer order parameters (includes invoice length, used in many A/R functions)
currparms_mst_all	General currency parameters
custaddr_mst	Customer address
customer_mst_all	Customers information
ExtFinAddBatchToBGQueueSp	External financials
inv_hdr_mst_all	Invoice header
inv_item_mst_all	Invoice line item
inv_stax_mst_all	Invoice sales tax
InvoiceBuilderCopySp	Copy invoice
InvoiceBuilderReprintSp	Reprint invoice
InvoicingBGSp	Invoicing background task
InvPostingArinvdSnapShotSp	Invoice posting - invoice/voucher distribution
InvPostingAutoDistSp	Invoice posting - auto distribution
InvPostingCreateTTSp	Invoice posting - create temp table
InvPostingLockJournSp	Lock journal during invoice posting
InvPostingSp	Invoice posting
InvPostingVerifyPrintSp	Invoice posting
item_mst_all	Items - used throughout the system
parms_mst_all	General parameters - used throughout the system
Rpt_InvoiceTransactionSp	

Journal Builder category

Journal Builder object name	Used for
chart_mst_all	Chart of accounts - used throughout the system
chart_unitcd1_mst_all	Unit code 1 information on chart of accounts
chart_unitcd2_mst_all	Unit code 2 information on chart of accounts
chart_unitcd3_mst_all	Unit code 3 information on chart of accounts
chart_unitcd4_mst_all	Unit code 4 information on chart of accounts

Replication category tables

Journal Builder object name	Used for
currparms_mst_all	General currency parameters
JournalBuilderProcessSp	Validation and processing of transactions listed in Journal Builder
parms_mst_all	General parameters - used throughout the system
unitcd1_mst_all	Display unit code description
unitcd2_mst_all	Display unit code description
unitcd3_mst_all	Display unit code description
unitcd4_mst_all	Display unit code description

Ledger Consolidation category

Ledger Console object name	Used for
ChangeReportsToCopyChartSp	Changes for reporting to different entity
ChangeReportsToCopyPeriodSp	Changes for reporting to different entity
ChangeReportsToCSp	Changes for reporting to different entity
ChangeReportsToDelPeriodsSp	Changes for reporting to different entity
ChangeReportsToPSP	Changes for reporting to different entity
ChangeReportsToSetCurrCodeSp	Changes for reporting to different entity
ChangeReportsToZSp	Changes for reporting to different entity
chart_mst_all	Chart of accounts (replicates only to child sites) - used throughout the system
ChartAcctRemoteSp	Replicate changes to chart of accounts to remote sites
curr_uk_mst_all	Customs and excise exchange rates
currate_mst_all	Currency rates - used throughout the system
currency_mst_all	Currency codes (local) - used throughout the system
currparms_mst_all	General currency parameters
DeleteRemoteNotesSp	Delete remote notes
euro_parms_mst_all	Euro parameters - used throughout the system
GLBudgetCommitSp	Commits budget by moving tmp_chart_bp_entity to chart_bp; adds unit codes if they don't exist.
GLBudgetConsChartBpUpdateSp	Used in budget consolidation

Ledger Console object name	Used for
GIBudgetDelChartbpSp	Delete hierarchy from chart_bp
LedgerConsolCommitSp	Add new transaction records into the entity ledger (for ledger consolidation). Also insert records into unitcd{1-4} tables based upon unit codes within ledger rows that are consolidated.
LedgerConsolConsolCtaSp	Update the CTA account (for ledger consolidation)
LedgerConsolCtaAdjSp	Adjust the CTA amount (for ledger consolidation)
LedgerConsolLedgerSp	Intermediate step in ledger consolidation
LoadReplicatedNotesSp	Take a row out of the NotesContentShadow table and updates the matching system, user, or specific note. If the note does not exist, it is created.
MakeRemoteObjectNotesSp	Create an ObjectNotes record at the remote site. It assumes the system, user, or specific notes records have already been created.
NotesContentShadow	System, user, or specific note information used to populate the appropriate notes record at the remote site.
parms_mst_all	General parameters - used throughout the system
periods_mst_all	Accounting periods - used in many financial areas
PeriodsRemoteDeleteSp	Delete accounting periods for a fiscal year
PeriodsRemoteSaveSp	Add or update accounting periods for a site
RepChartSp	Multi-site chart copy
TransferNotesToSiteSp	Transfer notes to a remote site

Ledger Detail category

Ledger Detail object name	Used for
chart_mst_all	Chart of accounts - used throughout the system
matltran_amt_mst_all	Material transactions
matltran_mst_all	Material transaction amounts
vch_pr_mst_all	Voucher pre-register
vch_pr_stax_mst_all	Voucher pre-register sales tax

Manufacturer Item category

Manufacturer Item object name	Used for
item_manufacturer_item_mst_all	Cross-reference of CloudSuite Business item to manufacturer item
manufacturer_item_mst_all	Items manufactured by other companies
manufacturer_mst_all	Manufacturers of items

Multi-Site Home form categories

These categories allow you to view related information from other sites in the appropriate Home form:

- Multi-Site Buyer
- Multi-Site Controller
- Multi-Site CRM (Salesperson Home)
- Multi-Site Controller
- Multi-Site Customer Service
- Multi-Site Inventory Control
- Multi-Site Production Planner
- Multi-Site Project Manager

Multi-Site BOM Builder category

Multi-Site BOM Builder object name	Used for
CreateCurrentMaterialReferenceSp	Current material references
CreateCurrentMaterialSp	Current materials
CreateCurrentOperationResourceGroupSp	Resource groups
CreateCurrentOperationSp	Current routing and scheduling
CreateItemFeatureRankSp	Item feature ranking
CreateRemoteNoteSp	BOM notes
MultiSiteBOMCopySp	Overall copy of BOM

Multi-Site Customers category

Multi-Site Customers object name	Used for
bank_hdr_mst_all	Bank information
country_mst	Countries - used throughout the system
currency_mst	Currency codes - used throughout the system
currparms_mst_all	Currency parameters
customer_mst	Customers
CustomerInsUpdSp	Insert/update customers
CustShipToInsUpdSp	Insert/update customer ship-tos
del_term_mst_all	Delivery terms
endtype_mst_all	End user type (sales accounts)
inv_category_mst_all	Invoice categories
pricecode_mst_all	Price codes
reason_mst_all	Reason codes
sales_team_mst_all	Sales teams
shipcode_mst_all	Ship codes
terms_mst_all	Billing terms
territory_mst_all	Sales territories
trans_nature_2_mst_all	Secondary NOTC codes
trans_nature_mst_all	NOTC codes

Multi-Site Items category

Multi-Site Items object name	Used for
aps_parm_mst_all	APS parameters
attribute_group_mst_all	Item attribute groups
attribute_value_mst_all	Item attribute values
commodity_mst_all	Commodity codes
country_mst_all	Countries
currparms_mst_all	General currency parameters

Replication category tables

Multi-Site Items object name	Used for
distacct_mst_all	Distribution accounts
exc_mesg_mst_all	
famcode_mst_all	Family codes
Home_MRPSupDemSp	
invparms_mst_all	Inventory parameters
item_mst_all	Item information - used throughout the system
ItemInsUpdSp	Insert/update items
itemloc_mst_all	Lot/locations
itempiece_mst_all	Item pieces
itemwhse_mst_all	Item/warehouses
job_mst_all	Job information - used throughout the system
jobmatl_mst_all	Job materials
jobroute_mst_all	Job routings
location_mst_all	Item locations
poparms_mst_all	Purchase order parameters
prod_mix_mst_all	Co-product mixes
prodcodes_mst_all	Product codes
reason_mst_all	Reason codes
setupgroup_mst_all	Setup groups
tax_free_import_item_mst_all	Tax free import items
u_m_mst_all	Unit of measures
whse_mst_all	Warehouses

Planning category

Planning object name	Used for
RepApsTplnBulkDelSp	Bulk deletion of planned transfer demand records
RepApsTplnDelSp	Delete planned transfer demand records
RepApsTplnSp	Create the planned transfer demand at the supplying site

PO - CO - Across Sites category

PO-CO object name	Used for
cfg_main_mst_all	Configuration details
co_bln_mst_all	Customer orders
co_mst_all	Blanket orders
coitem_mst_all	Customer order lines
country_mst_all	Countries
currency_mst_all	General currency parameters
cust_lcr_mst_all	Customer letters of credit
custaddr_mst	Customer addresses
customer_mst_all	Customers
del_term_mst_all	Delivery terms
DemandingPoCoUnlinkSp	Unlink the Source Site to remove the PO-CO relationship.
DemandingPoSourceCoSyncSp	From the Demanding Site to the Source Site, generate and sync the Source Site CO based on changes to the Demanding Site's PO.
itemwhse_mst_all	Item warehouse
MakeRemoteObjectNotesCrossTableSp	Transfer demand PO line notes to source site customer order line
matltran_mst_all	Material transactions
parms_mst_all	General parameters
po_bln_mst_all	Purchase orders
po_mst_all	Blanket purchase orders
poitem_mst_all	Purchase order lines
preassigned_lot_mst_all	Preassigned lots
serial_mst_all	Serial numbers
slsman_mst_all	Salespersons
SyncCoFromPoSp	Synchronize customer order from purchase order
UpdateCoNumonDemandingPoSp	On shipping of the CO, update the PO based on flag settings
vendor_mst_all	Vendors

Purchase Order Builder category

PO Builder object name	Used for
apparms_mst_all	Accounts payable parameters - used in A/P payment distribution and generation
bank_hdr_bank_file_fmt_mst_all	Bank header bank file format information
BuilderPOUpdateSp	In print site, update temp table with PO data from remote sites, to create Builder PO Report
chart_mst_all	Chart of accounts (replicates only to child sites) - used throughout the system
chart_unitcd1_mst_all	Unit code 1 information on chart of accounts
chart_unitcd2_mst_all	Unit code 2 information on chart of accounts
chart_unitcd3_mst_all	Unit code 3 information on chart of accounts
chart_unitcd4_mst_all	Unit code 4 information on chart of accounts
currency_mst_all	Currency codes (local) - used throughout the system
currparms_mst_all	General currency parameters
ExecuteSQLSp	Loads PLN data from other site
item_mst_all	Items - used throughout the system
parms_mst_all	General parameters - used throughout the system
po_bln_mst_all	Purchase orders
po_mst_all	Blanket purchase orders
POBuilderCopySp	Copy temp table data from Builder PO site to target sites
POBuilderCreateSp	Create PO in target site
poitem_mst_all	Purchase order lines
shipcode_mst_all	Shipping codes
shipto_mst_all	Ship To information
u_m_conv_mst_all	Unit of measure codes (all sites)
u_m_mst_all	Unit of measure conversion
unitcd1_mst_all	Unit code description
unitcd2_mst_all	Unit code description
unitcd3_mst_all	Unit code description
unitcd4_mst_all	Unit code description
vendcat_mst_all	Vendor categories

PO Builder object name	Used for
vendor_mst_all	Vendor information - used throughout the system
whse_mst_all	Warehouses

Service - Global Incidents category

Service- Global Incidents object name	Used for
DeleteRemoteNotesSp	Delete remote notes
fs_consumer_mst	Consumers
fs_event_code_mst	Service event code
fs_event_mst	Service event
fs_event_mst_all	Service event - remote sites
fs_inc_reason_mst	Incident reason
fs_inc_stat_mst	Incident status
fs_incident_mst	Incidents
fs_incident_mst_all	Incidents - remote sites
fs_partner_mst_all	Partners
fs_prior_code_mst	Priority codes
fs_reas_gen_mst	General reasons
fs_reas_spec_mst	Specific reasons
fs_res_gen_mst	
fs_res_spec_mst	
fs_sro_line_mst_all	Service order lines
fs_sro_mst_all	Service orders
fs_sro_oper_mst_all	Service order operations
fs_stat_code_mst	Status codes
SSSFSSROCopyCreateSroSp	Create or copy service orders
SSSFSSROCopyLinesSp	Copy lines
TransferNotesToSiteSp	Copy lines to remote sites

Service - Global Scheduling Shared Partners category

Service- Global Scheduling Shared Partner object name	Used for
certification_mst	Certification
fs_appt_stat_mst	Appointment status
fs_appt_type_mst	Appointment type
fs_incident_mst_all	Incidents
fs_partner_area_mst	Partner area
fs_partner_cert_mst	Partner certification
fs_partner_loc_mst	Partner location
fs_partner_mst	Partners
fs_partner_skill_mst	Partner skills
fs_partner_team_mst	Partner teams
fs_region_mst	Regions
fs_schedule	Schedules
fs_sro_line_mst_all	Service order lines
fs_sro_mst_all	Service orders
fs_sro_oper_mst_all	Service order operations
skill_mst	Skills

Service - Global Service History category

Service- Global Service History object name	Used for
fs_consumer_mst	Consumers
fs_cont_line_mst_all	Contract lines
fs_contract_mst_all	Contracts
fs_customer_mst_all	Customers
fs_event_mst_all	Service events
fs_incident_mst_all	Incidents
fs_partner_mst_all	Partners

Service- Global Service History object name	Used for
fs_sro_line_mst_all	Service order lines
fs_sro_mst_all	Service orders
fs_sro_oper_mst_all	Service order operations
fs_unit_cons_mst_all	Unit configurations
fs_unit_meter_mst_all	Unit metering
fs_unit_mst_all	Units
fs_unit_stat_mst_all	Unit status

Service - Global Units category

Service - Global Units object name	Used for
fs_config_mst	Configurations
fs_consumer_mst	Consumers
fs_partner_mst_all	Partners
fs_unit_cons_mst	Unit configurations
fs_unit_mst	Units
fs_unit_stat_code_mst	Unit status codes
fs_unit_stat_mst	Unit status
fs_unit_warr_mst	Unit warrantys
fs_warr_code_mst	Unit warranty codes
reason_mst	Reasons
whse_mst_all	Service warehouses

Service - Multi-Site SRO Copy category

Service - Multi-Site SRO Copy object name	Used for
SSSFSMultiSiteSroCopySp	Copy service order to remote site

Service - Multi-Site SRO Copy object name	Used for
SSSFSMultiSiteSroSubCopySp	Copy service order to remote site

Shared Currency category

Shared Curr object name	Used for
country_mst	Country codes - used throughout the system
curr_uk_mst	Customs and excise exchange rates
CurrAcctSp	Create a curracct row in the remote site for the currency row just added in the local site. (The record is created but account information is not replicated.)
currate_mst	Currency rates - used throughout the system
currency_mst	Currency rates - used throughout the system

Site Admin category

Site Admin object name	Used for
chart_mst_all	Chart of accounts - used throughout the system
DefineVariableSp	Define variables for translation strings
EmailType	Email type from Users
intranet	Intranets
IntranetSharedTable	Intranet shared tables
PasswordParameters	Password verification
RemoteDataPullSp	Bulk copy of data between connected databases
site	Sites/entities - used throughout the system
site_group	Site groups - used throughout the system
site_hierarchy	Site hierarchy (Reports To entity)
site_link_info	Linked sites
sitenet_mst	Inter-site parameters

Site Admin object name	Used for
system_type	System types
UpdateAllTablesSp	Update _All tables
UserNamesRemoteUpdateSp	User password, e-mail address, and workstation login

Vendor Portal category

Vendor Portal object name	Used for
PortalAccountCreateOrCopySp	Create or copy portal user account

Voucher Builder category

Voucher Builder object name	Used for
aptrx_mst_all	A/P transactions
aptrxp_mst_all	A/P posted transactions - used in many A/P areas
currparms_mst_all	General currency parameters
item_mst_all	Items - used throughout the system
lc_rcpt_mst_all	Landed cost receipts
ManualVoucherBuilderProcessSp	Manual voucher builder
parms_mst_all	General parameters - used throughout the system
po_mst_all	Purchase orders
po_rcpt_mst_all	Purchase order receipts
po_vch_mst_all	Purchase order voucher log
poitem_mst_all	Purchase order lines
poparms_mst_all	Purchase order parameters
tax_system_mst_all	Tax systems - used in A/P payment generation and A/P check/draft/wire/EFT printing/posting
trans_nature_2_mst_all	Nature of transaction codes
trans_nature_mst_all	Secondary nature of transaction codes
u_m_conv_mst_all	Unit of measure codes (all sites)

Replication category tables

Voucher Builder object name	Used for
u_m_mst_all	Unit of measure conversion
vch_hdr_mst_all	Voucher register
vendaddr_mst	Vendor addresses
vendor_mst_all	Vendor information - used throughout the system
VoucherBuilderCopySp	Copy selected tmp_voucher_builder rows from Builder Voucher originating site to target site
VoucherBuilderCreateVoucherSp	Runs in the site where voucher or an adjustment needs to be created. Performs validations based on target site's data, calls procedures to calculate taxes based on target site's tax codes, and calls procedures to create one un-posted voucher, voucher distributions including tax distributions, and voucher register rows.

Glossary

A/P

Accounts payable

A/R

Accounts receivable

APS

Advanced Planning System, which generates real-time projections of when you can complete orders by comparing all demands (such as customer orders) against a long-term plan. The system views the current status of inventory levels, forecasts, job schedules, PO due dates, customer orders, etc. and creates planned orders accordingly to satisfy the demands. You then "firm" the planned orders into purchase orders, purchase requisitions, job orders, production schedules, or transfer orders.

Asynchronous replication

Another term sometimes used for non-transactional replication.

ATP

Available to Promise function of APS.

BOD

Business Object Document, an XML document standard defined by Open Applications Group Integration Specifications (OAGIS). This type of document is used when interfacing with many other Infor applications.

BOM

Bill of Material, which is a listing of all the subassemblies, intermediates, parts, and raw materials that go into a parent assembly showing the quantity of each required to make an assembly.

CO

Customer order

Configuration server

A framework component that dynamically gives the client a URL to use for its session, drawing on a pool of utility servers configured by the system administrator.

CPM

Infor performance management solution providing a closed loop between strategy, planning, budgeting, financial reporting and analysis. CPM interfaces with CloudSuite Business and also with Infor financial management solutions.

CPQ

Product configuration application that interfaces with Cloud Suite Business. Formerly known as BuyDesign or PCM.

CTP

Capable to Promise function of APS

Data collection

Collection of data through handheld devices or barcode readers.

EAM

Infor enterprise asset management application that interfaces with CloudSuite Business.

EDI

Electronic Data Interchange, which allows companies to exchange transaction data through data files in an ANSI standard format. CloudSuite Business is integrated with an EDI translator. CloudSuite Business imports inbound transactions from the translator and exports outbound transactions to the translator.

Entity

A level of business operation with a complete set of financial statements, its own defined currency code and rates, and its own chart of accounts and accounting periods. An entity does not allow for business activity aside from period, chart, and currency maintenance and the reporting of its consolidated ledger and budgets. See "Entities" on page 41.

FOB

Free On Board. The site designated as the FOB point controls much of the CloudSuite Business costing functionality. In the Transfer Order system, you can identify the FOB point as either the Ship Site or the Receive Site. You must specify the FOB point for all inter-company movements.

Form

In the CloudSuite Business user interface, the equivalent of a screen or a window. See .

G/L

General ledger

Intranet

In CloudSuite Business, represents a logical grouping of sites in your enterprise. An intranet may represent a grouping of CloudSuite Business sites that exist together on a high-speed network, and for which you want common administration. (Common administration can include replication, or creation of master sites.) An intranet may also represent an external non-CloudSuite Business system, allowing you to set up replication rules between CloudSuite Business sites and external systems.

Intranet licensing

Optional feature where licensing for all sites on an intranet is maintained in and controlled by the master site for the intranet.

Landed cost

Includes freight, duty, brokerage, insurance, and local freight on purchase orders, transfer orders, or goods receiving notes.

License module

Gives users access to certain specified functionality within CloudSuite Business. You purchase specific license modules based on your company's needs.

For example, if your company is planning to use APS, you would purchase the AdvancePlanningScheduling license module.

Lot-tracked item

Item that is marked as being in a specific lot, which is a quantity produced together and sharing the same production costs and resulting specifications.

Master site

CloudSuite Business site that controls some data for all other sites on an intranet. For example, master sites are used with the Multi-Site Shared Tables feature.

MRP

Material Requirements Planning, which plans requirements in order by the lowest level in which the item appears in a bill of material. That is, it plans all end items first, then all items at the next level, and so on, backward planning each requirement from the requirement's needed date to the item's lead time, batching together requirements needed at the same period of time.

Multi-site table

A database table that includes a site_ref column. Records for various sites are stored in the table, and the value of the site_ref column determines which site the record belongs in.

Non-transactional replication

Uses inbound/outbound queues and XML documents to replicate content (data) or to pass application calls (RPCs). Non-transactional replication can occur at any of these intervals: Immediate (which means updates go directly into the replication queue), or at a set number of minutes, hours, or days. Once the data is in the queue, it will be processed by the Replication service when the specified time interval has elapsed.

PLM

Infor product lifecycle management application that interfaces with CloudSuite Business

PO

Purchase order

PortalSiteGroup data source

The multiplex data source that includes all CloudSuite Business sites that are included in the portal group of sites.

PrimarySite data source

For Customer Portal and Vendor Portal, the data source that points to a site in the portal site group. This site is the default data source, where all items and item categories, and certain other data, are maintained.

Pro forma invoice

A document that verifies the value of goods, when the goods cross borders. The value of goods is in the from-warehouse's or the from-site's domestic currency. Although pro forma invoices are typically used for international shipping transactions, you can also use them for domestic shipping transactions if desired.

Pull transaction

Transaction that moves or transfers material from Site B to Site A.

For example, Site A moves material from Site B. Site A is considered the To Site and Site B is considered the From Site. The quantity will be moved from Site B to Site A. The quantity comes from Site B to Site A. The transaction uses the cost/price of Site B.

Push transaction

Transaction that moves or transfers material from Site A to Site B.

For example, Site A moves material to Site B. Site A is considered the From Site and Site B is considered the To Site. The quantity will be moved from Site A to Site B. The quantity comes from the From Site. The transaction uses the cost/price of Site A.

Replication

The copying of data between CloudSuite Business sites

Site

Logically, any place where work is done. Thus, a site can correspond to company headquarters, a manufacturing plant, a distribution center, or a legal company that requires financial reporting. Even if all of these facilities share a single physical building, each can be considered a logical site.

Stored procedure

A group of SQL statements compiled into a single execution plan. Stored procedures are stored in the SQL database and executed upon request - through database triggers or calls from an application.

Synchronous replication

Another term sometimes used for transactional replication

Token

Allows one user login for a specified license module. Named user and concurrent user licenses are available, and their use of tokens is different. See the *Infor Cloud Suite Business Licensing Administration Guide* for more information.

Transactional replication

A live constant connection from one site to another. Cloud Suite Business replicates the transaction to the remote site as soon as the user at one site saves changes. It assumes that both the source and target sites are always connected through SQL Server and have the same schema.

Trigger

A special class of stored procedure defined to execute automatically when an UPDATE, INSERT, or DELETE statement is issued against a database table or view. Sites use triggers to enforce business rules automatically when data is modified.

View

A mechanism for gathering elements from SQL tables and assembling them into a virtual table. Generated views simplify database queries by eliminating the need to understand the underlying structure of a database. In Cloud Suite Business, views can be used with master sites, allowing other sites in the intranet to maintain data at the master site.

Also refers to multiple "views" (different data sets) available on CloudSuite Business forms such as Customer Inquiry and Vendor Inquiry.

WIP

Work in process for a product or products in various stages of completion throughout the plant, including all material from raw material that has been released for initial processing up to completely processed material awaiting final inspection and acceptance as finished product. Many accounting systems also include the value of partially finished stock and components in this category.

